

ASSEMBLY INSTRUCTION

EXTENDABLE TABLE

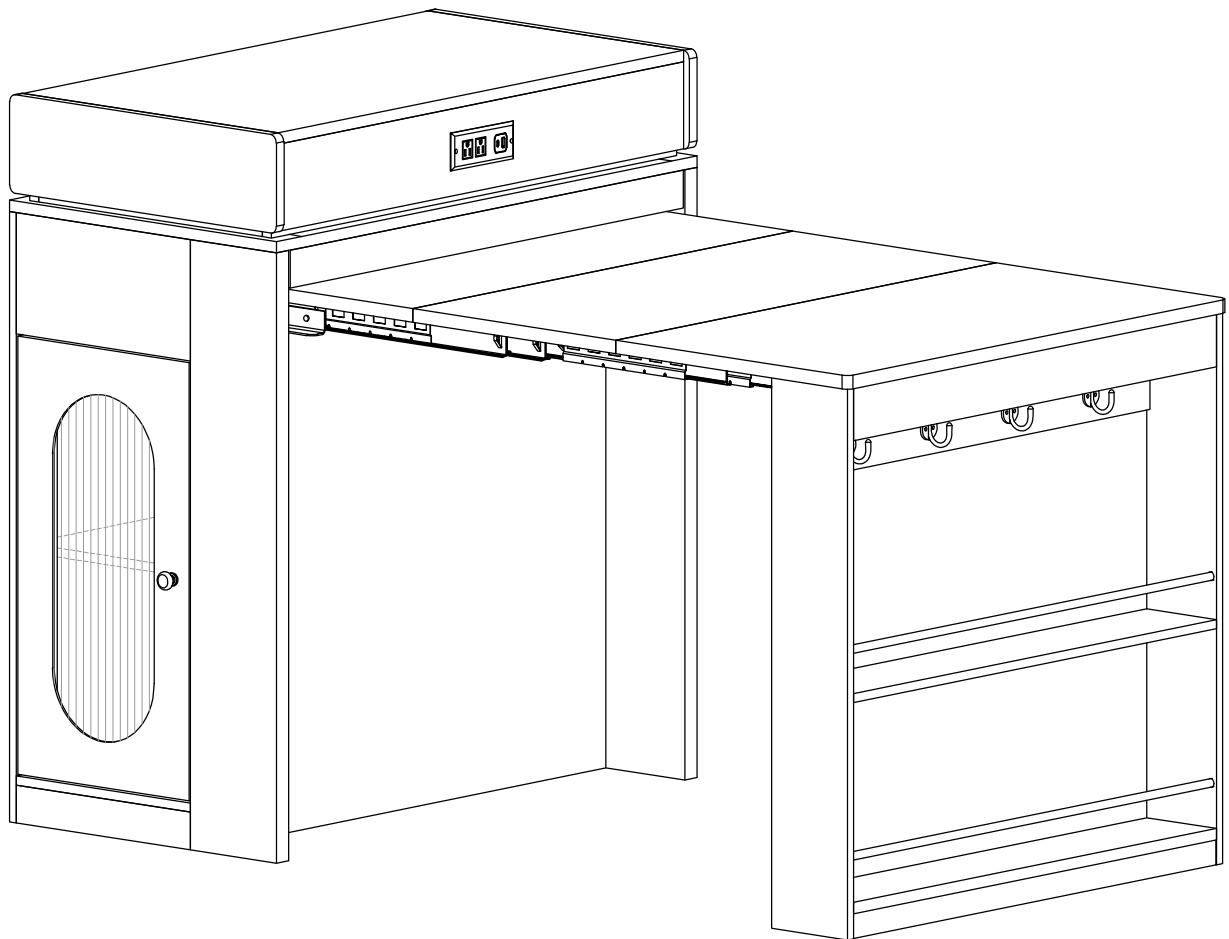

ASSEMBLY INSTRUCTION

Important - Please read these instructions fully before starting assembly

- Check you have all the components and tools listed on the following pages.
- Remove all fittings from the plastic bags and separate them into their groups.
- Keep children and animals away from the work area, small parts could choke if swallowed.
- Make sure you have enough space to layout the parts before starting.

- During assembly do not stand or put weight on the product, this could cause damage.
- Assemble the item as close to its final position (in the same room) as possible.
- Assemble on a soft level surface to avoid damaging the unit or your floor.
- Parts of the assembly will be easier with 2 people.



your power drill is set on low torque setting.

- To reduce the likelihood of damaging your product please ensure that

Care and maintenance

- Only clean using a damp cloth and mild detergent, do not use bleach or abrasive cleaners.
- From time to time check that there are no loose screws on this unit.
- This product should not be discarded with household waste. Take to your local authority waste disposal centre.

Handy Hints

- Assemble all parts and bolts loosely during assembly, only once the product is complete should you fully tighten the bolts
- Regularly check and ensure that all bolts and fittings are tightened properly.

WARNING

In order to help prevent overturning - please follow these instructions

To help prevent product toppling over please follow the below steps:-

Use the anti tip strap or wall fixing method provided (if applicable)

Do not allow children to climb or hang on the furniture

Do not open more than one drawer at a time

Do not place heavy items in the top drawers

Do not place heavy items on top of the furniture, unless the furniture has been designed for this purpose

Please note that only the anti tip strap is provided.

You will need to provide wall plugs and screws applicable for your wall type

Tools required



Screwdrivers can be converted to Phillips and Slotted.

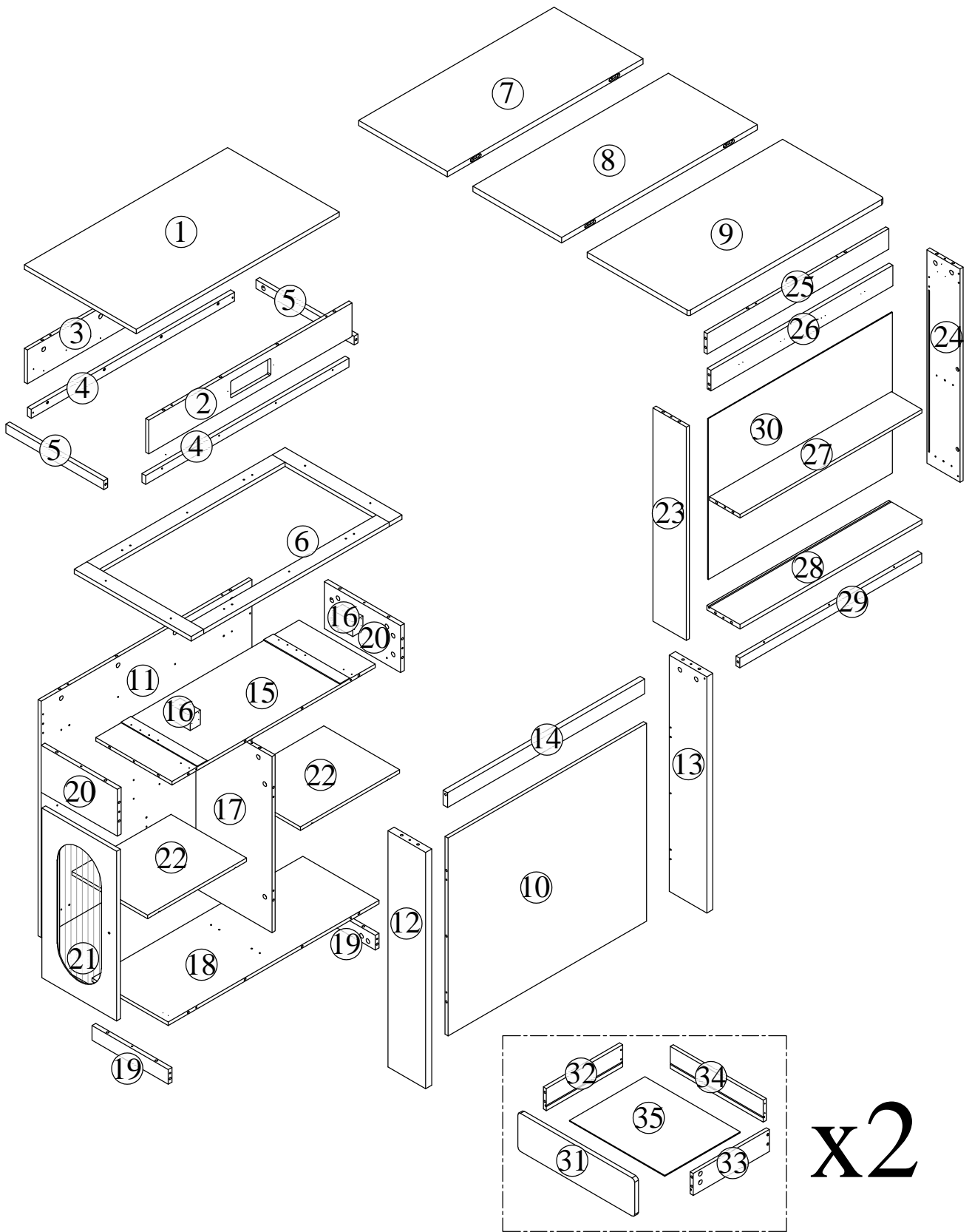



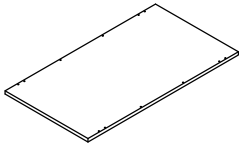
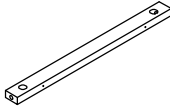
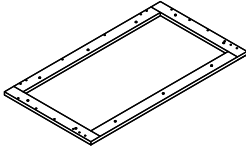
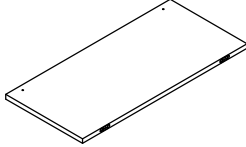
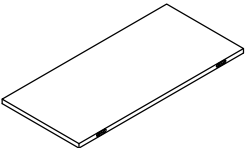
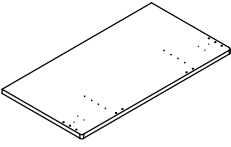
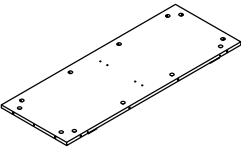
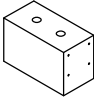
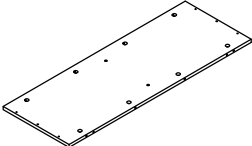
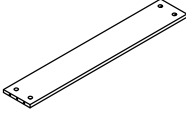
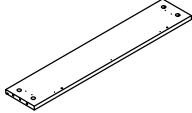



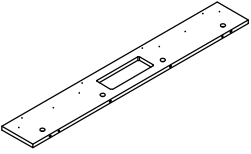
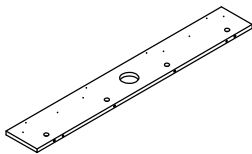
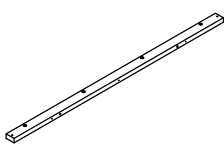
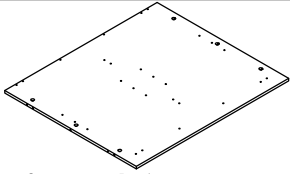
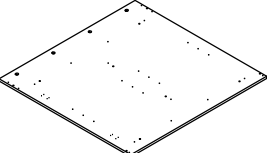
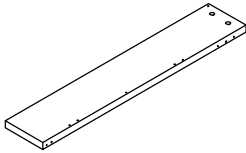
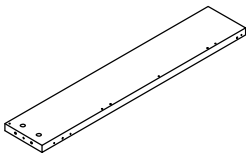
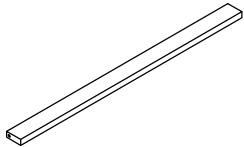
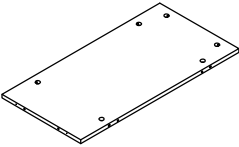
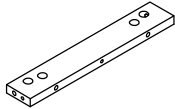
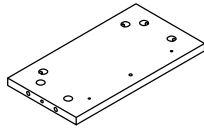
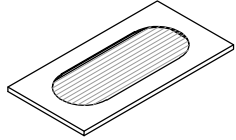
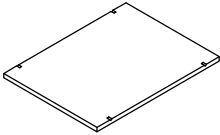
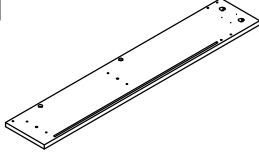
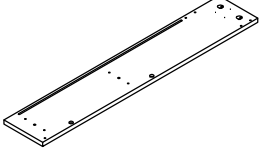
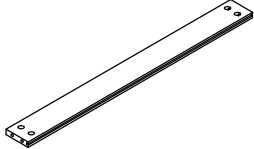
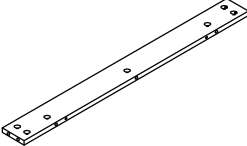
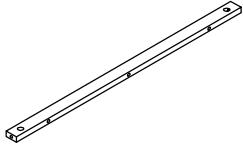
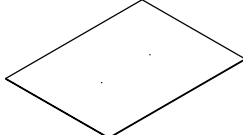
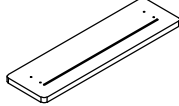
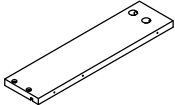
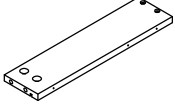
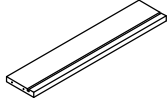
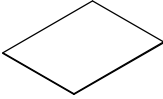
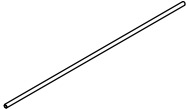



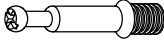



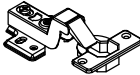

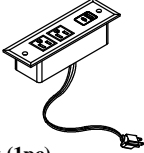





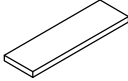

PART LIST

1  Top panel - 1pc	5  Up side bottom panel - 2pcs	6  Middle frame - 1pc	7  Top panel - 1pc
8  Top panel - 1pc	9  Top panel - 1pc	15  Middle panel - 1pc	16  Little piece of wood - 2pcs
18  Bottom panel - 1pc	27  Middle panel of the activity rack - 1pc	28  Bottom panel of the activity rack - 1pc	

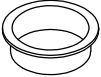
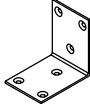
PART LIST

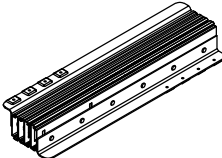
<p>2</p>  <p>Up front panel - 1pc</p>	<p>3</p>  <p>Up back panel - 1pc</p>	<p>4</p>  <p>Up front and back bottom rail - 2pcs</p>	<p>10</p>  <p>Lower front panel - 1pc</p>
<p>11</p>  <p>Lower back panel - 1pc</p>	<p>12</p>  <p>Left side panel - 1pc</p>	<p>13</p>  <p>Right side panel - 1pc</p>	<p>14</p>  <p>Middle rail - 1pc</p>
<p>17</p>  <p>Neutral plate - 1pc</p>	<p>19</p>  <p>Rail - 2pcs</p>	<p>20</p>  <p>Side panel - 2pcs</p>	<p>21</p>  <p>Door - 1pc</p>
<p>22</p>  <p>Adjustable shelf - 2pcs</p>	<p>23</p>  <p>Left plate of the activity rack - 1pc</p>	<p>24</p>  <p>Right plate of the activity rack - 1pc</p>	<p>25</p>  <p>Up front rail - 1pc</p>
<p>26</p>  <p>Up back rail - 1pc</p>	<p>29</p>  <p>Lower front rail - 1pc</p>	<p>30</p>  <p>Back panel - 1pc</p>	<p>31</p>  <p>Drawer front panel - 2pcs</p>
<p>32</p>  <p>Drawer left side panel - 2pcs</p>	<p>33</p>  <p>Drawer right side panel - 2pcs</p>	<p>34</p>  <p>Drawer back panel - 2pcs</p>	<p>35</p>  <p>Drawer bottom panel - 2pcs</p>
<p>Z</p>  <p>Steel pipe - 2pcs</p>			

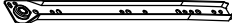
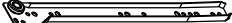
HARDWARE LIST

<p>A</p>  <p style="text-align: center;">Ø6.5*35mm</p> <p>Minifix (104+3pcs)</p>	<p>B</p>  <p style="text-align: center;">Ø15*9mm</p> <p>Minifix cap (104+3pcs)</p>	<p>C</p>  <p style="text-align: center;">Ø6*30mm</p> <p>Wood dowel (54+3pcs)</p>	<p>D</p>  <p style="text-align: center;">Ø4*35mm</p> <p>Wood screw (27+2pcs)</p>
<p>E</p>  <p style="text-align: center;">Ø4*25mm</p> <p>Wood screw (8+1pcs)</p>	<p>F</p>  <p>Soft close hinges (2pcs)</p>	<p>G</p>  <p style="text-align: center;">Ø4*12mm</p> <p>Wood screw (36+2pcs)</p>	<p>H</p>  <p>Insert Row (1pc)</p>
<p>I</p>  <p>Locating piece (2pcs)</p>	<p>J</p>  <p style="text-align: center;">Ø3*12mm</p> <p>Wood screw (38+2pcs)</p>	<p>K</p>  <p>Hinges (4pcs)</p>	<p>L</p>  <p style="text-align: center;">Ø4*19mm</p> <p>Wood screw (16+1pcs)</p>
<p>M</p>  <p>Handle (1pc)</p>	<p>N</p>  <p>Shelf support (8+1pcs)</p>	<p>O</p>  <p>Hook (4pcs)</p>	<p>P</p>  <p style="text-align: center;">Ø5*16mm</p> <p>Wood screw (16+1pcs)</p>
<p>Q</p>  <p>Allen wrench (1pc)</p>	<p>R</p>  <p>Plastic baffle (1pc)</p>	<p>S</p>  <p>Felt pad (8+1pcs)</p>	<p>T</p>  <p>Caster wheels (2pcs)</p>
<p>U</p>  <p>Outlet cover (1pc)</p>	<p>V</p>  <p>L-shaped iron sheet (2pcs)</p>	<p>W</p>  <p>Spring bolt (2pcs)</p>	<p>X</p>  <p>Slide rail (2pcs)</p>
<p>Y</p>  <p style="text-align: center;">M4*16mm</p> <p>Bolt (1pc)</p>	<p>CL</p>  <p style="text-align: center;">300mm</p> <p>Slide rail (2pcs)</p>	<p>CR</p>  <p style="text-align: center;">300mm</p> <p>Slide rail (2pcs)</p>	<p>DL</p>  <p style="text-align: center;">300mm</p> <p>Slide rail (2pcs)</p>
<p>DR</p>  <p style="text-align: center;">300mm</p> <p>Slide rail (2pcs)</p>			

Step 1

x2

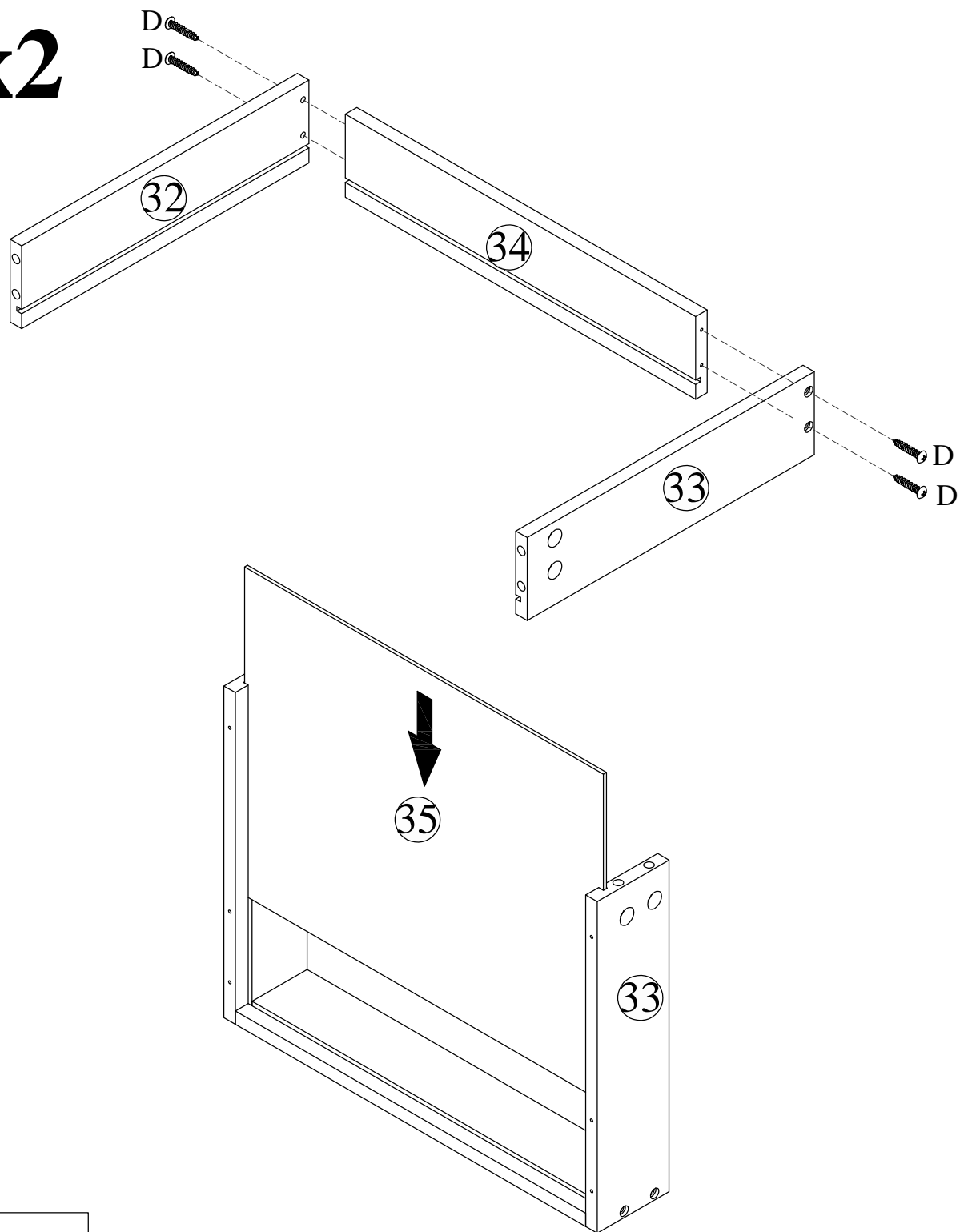



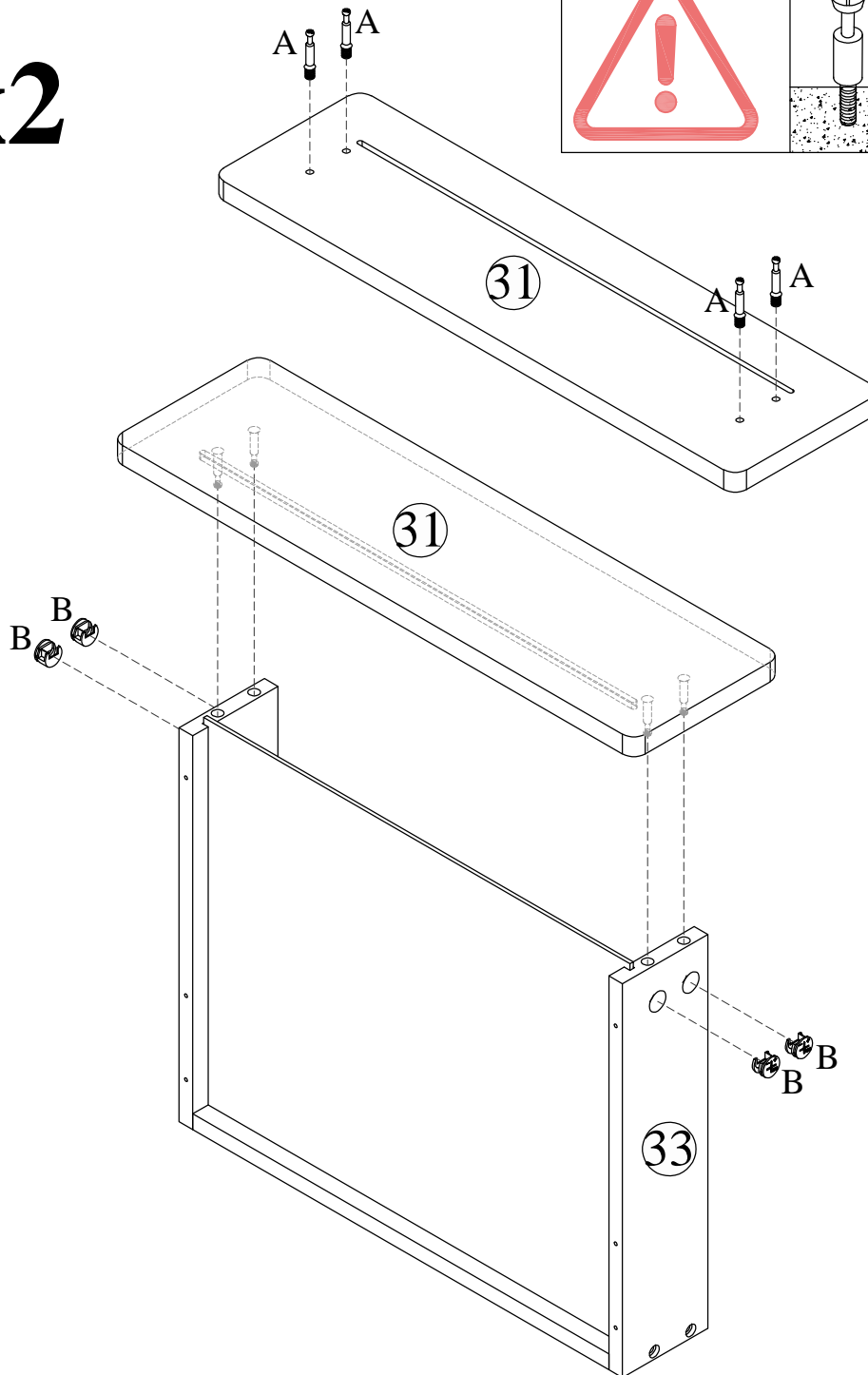
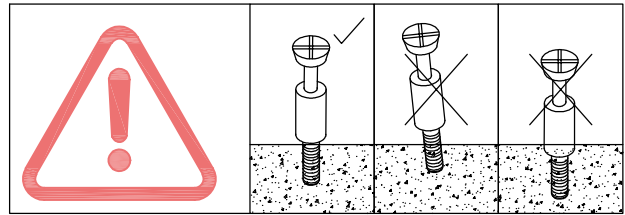

Ø4*35mm
D X 8

Step 2

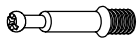
x2

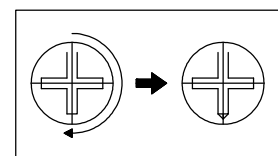

	
Ø6.5*35mm	Ø15*9mm
A X 8	B X 8



Lock Minifix cap clockwise

Step 3

x2

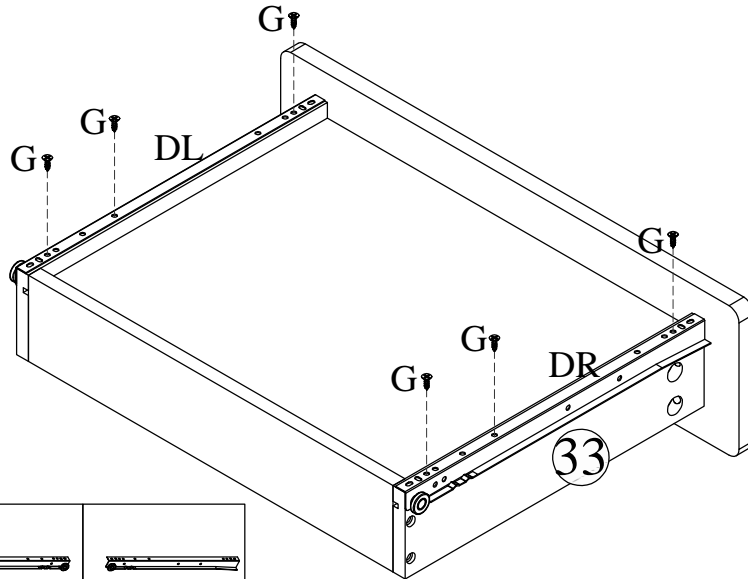

Ø4*12mm	300mm	300mm
G X 12	DL X 2	DR X 2

Step 4

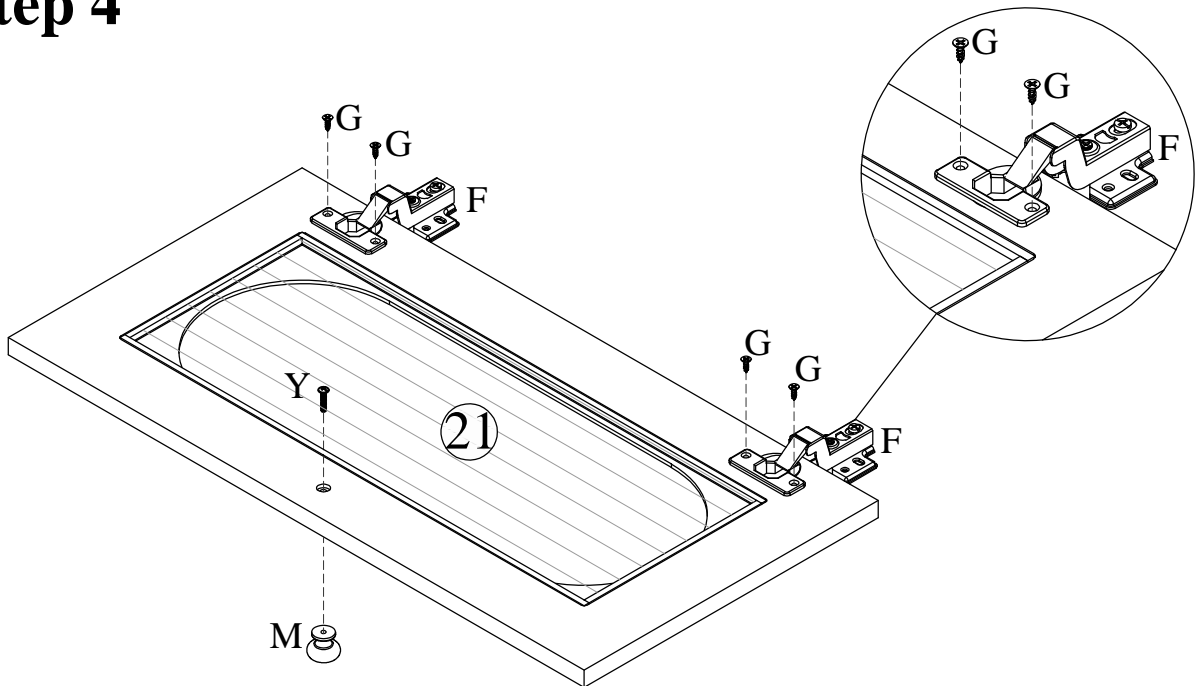

	Ø4*12mm		M4*16mm
FX 2	G X 4	MX 1	Y X 1

Step 5

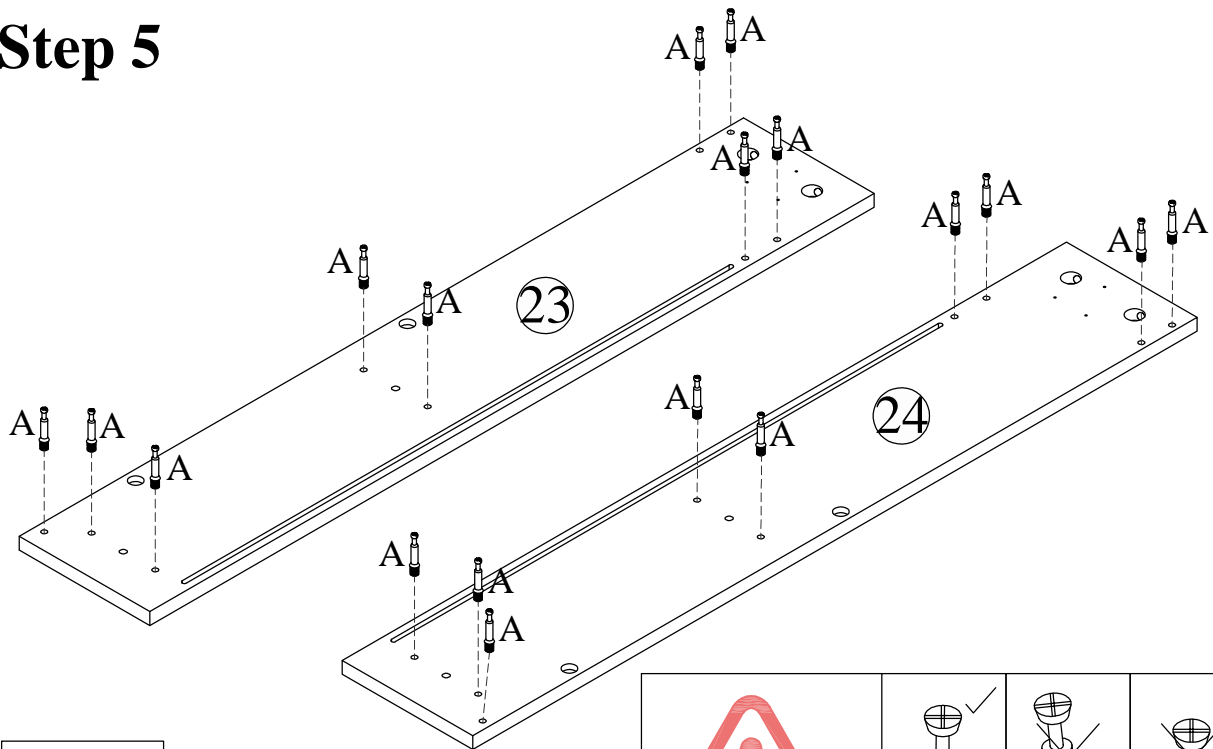

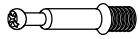

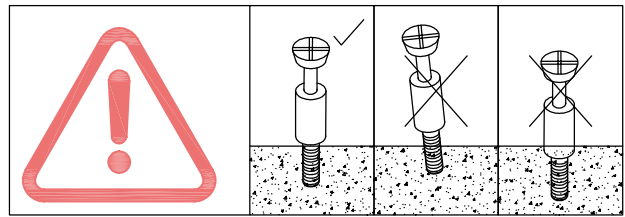

06.5*35mm
A X 18

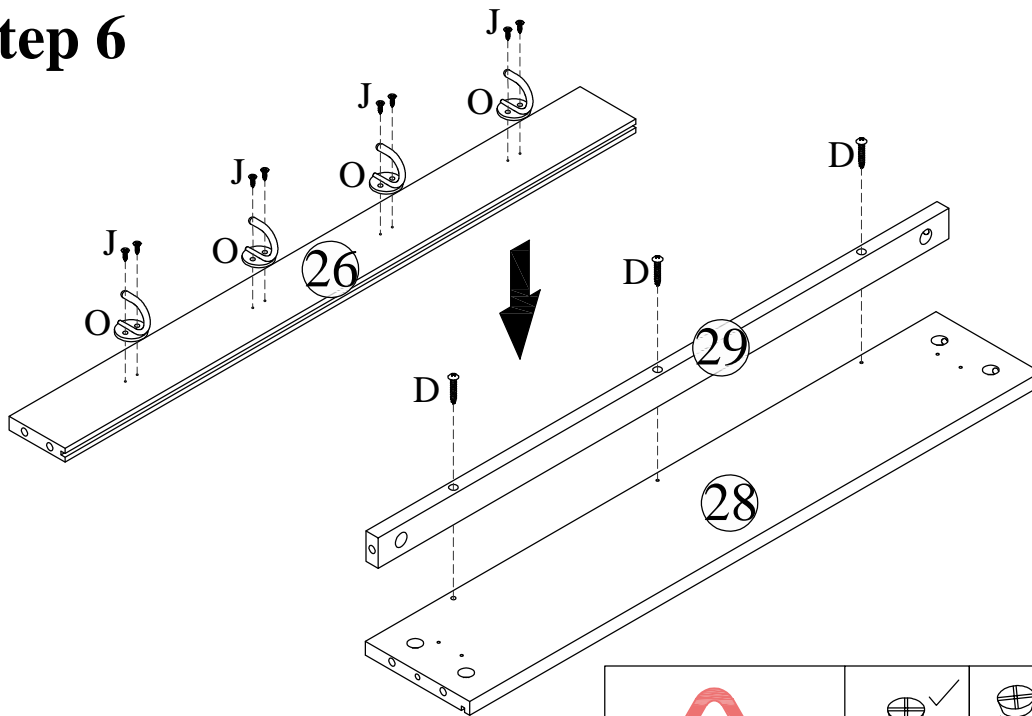

Step 6

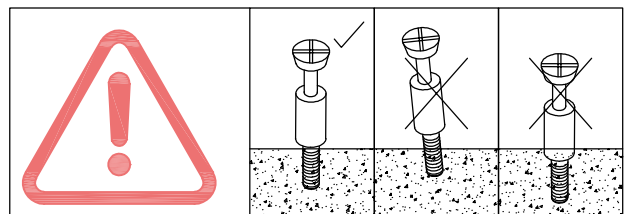

		
04*35mm	03*12mm	
D X 3	J X 8	O X 4



Step 7

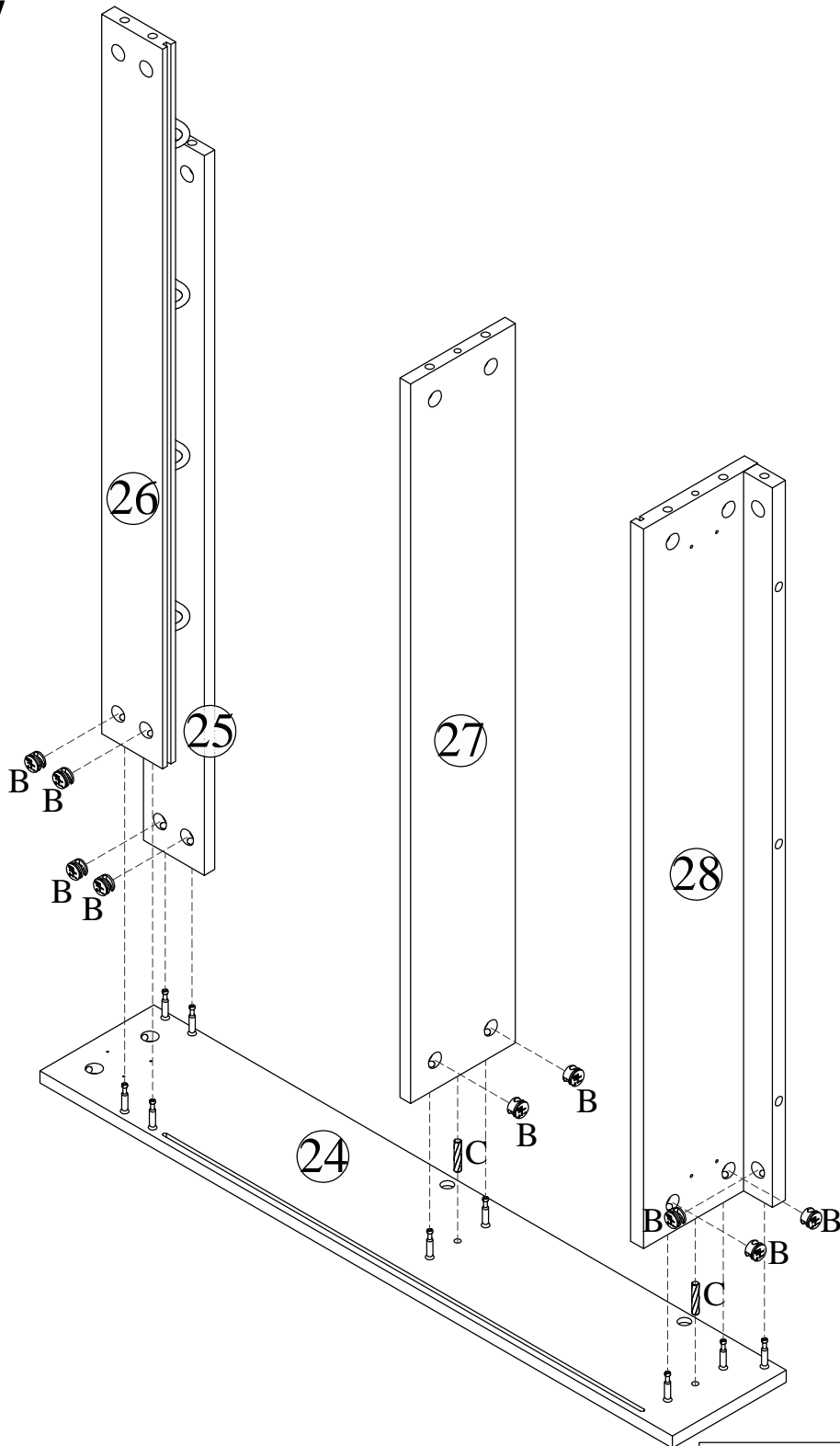

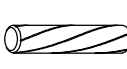
	
Ø15*9mm	Ø6*30mm
B X 9	C X 2

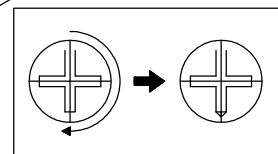



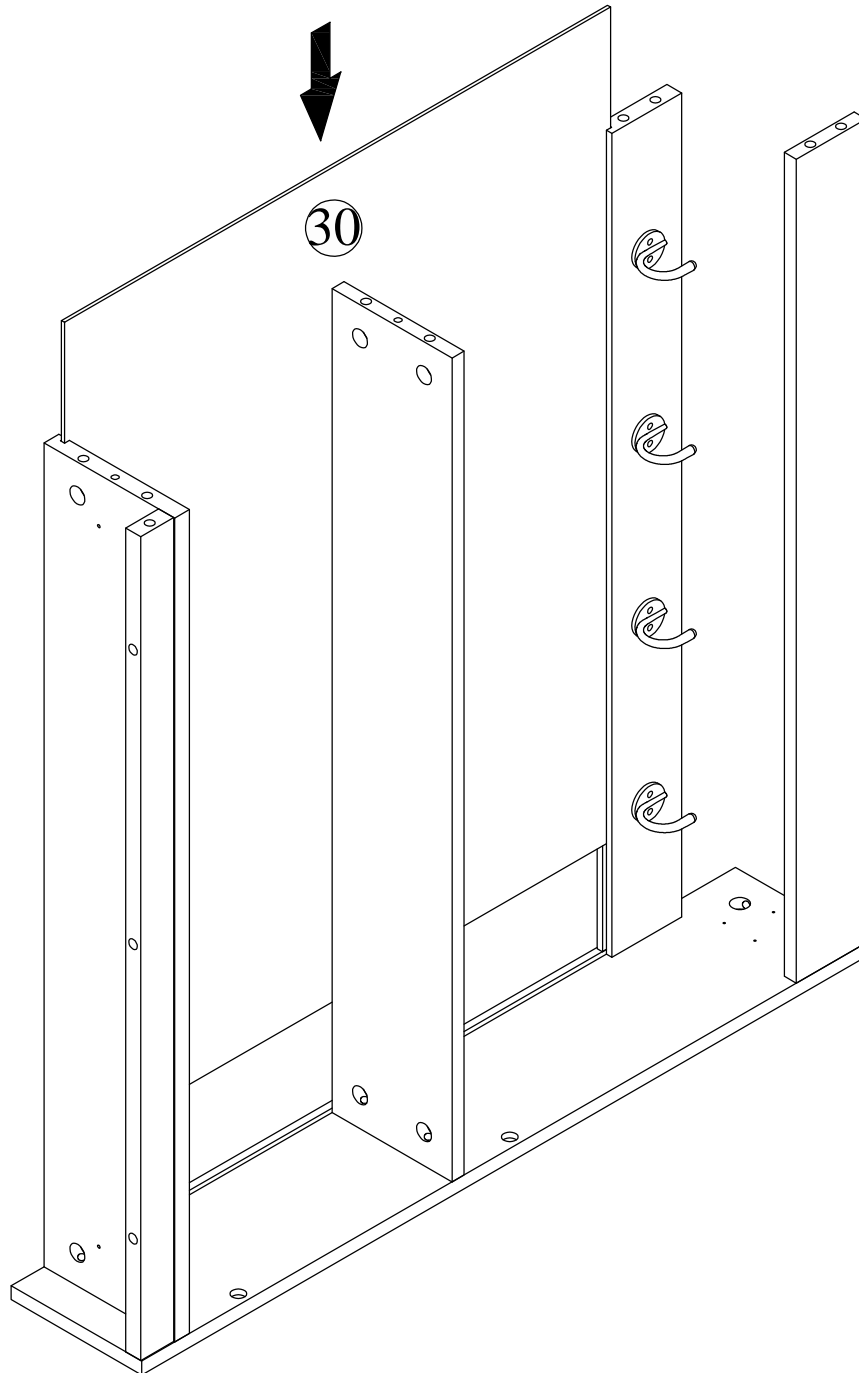

Lock Minifix cap clockwise

Step 8

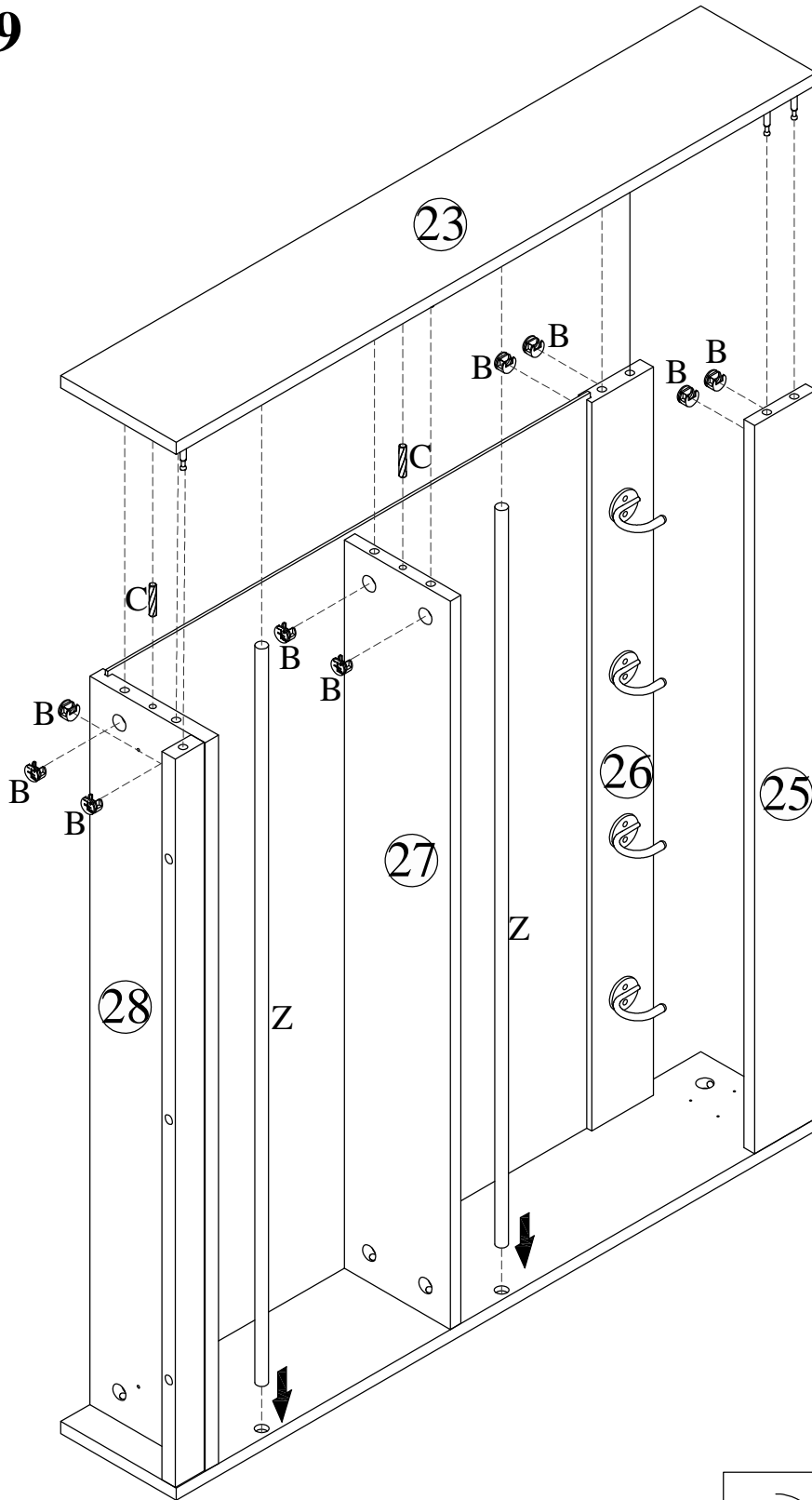

Step 9

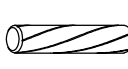

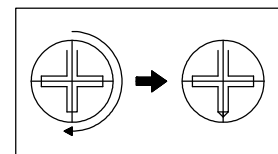

		
Ø15*9mm	Ø6*30mm	
B X 9	C X 2	Z X 2

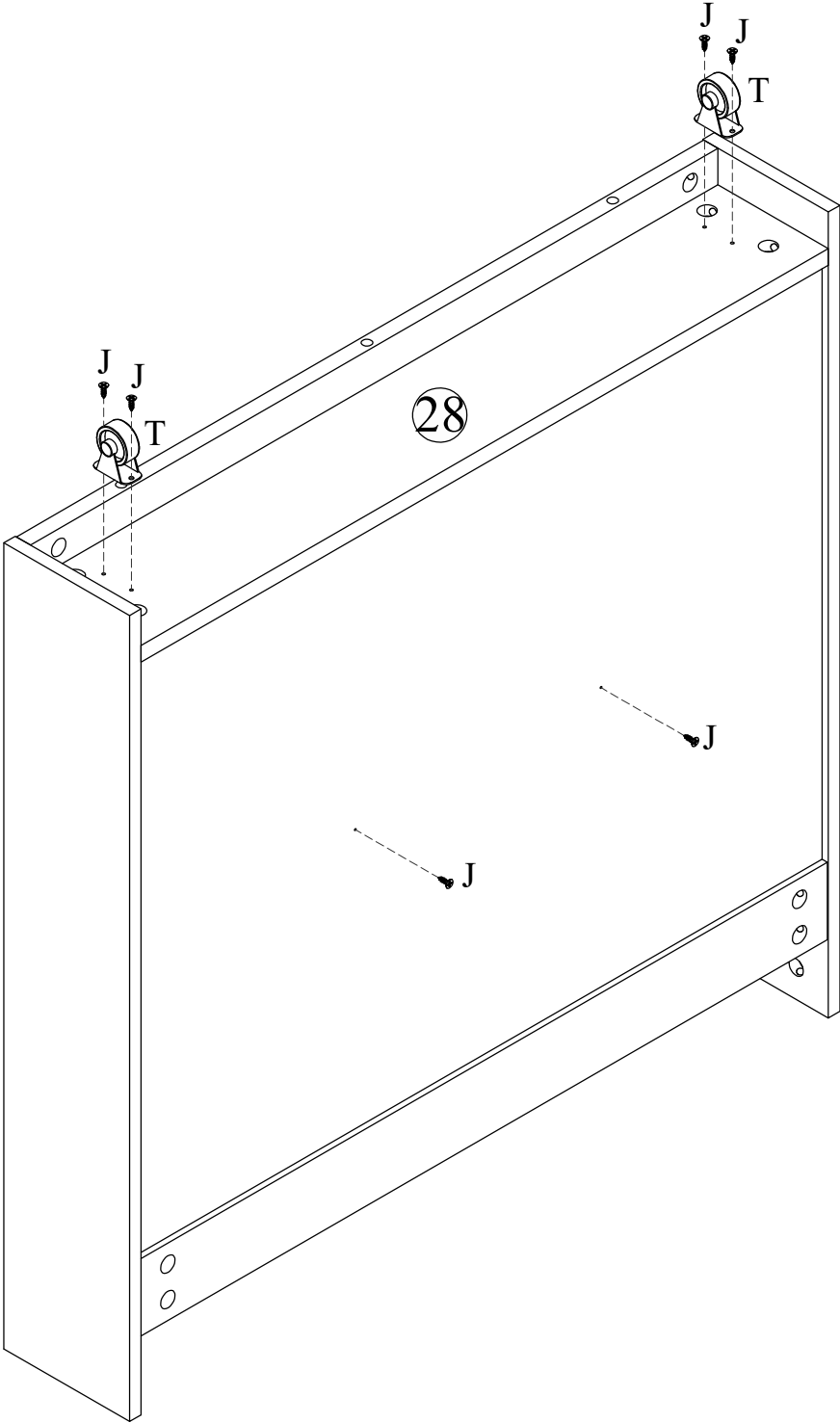

Lock Minifix cap clockwise

Step 10



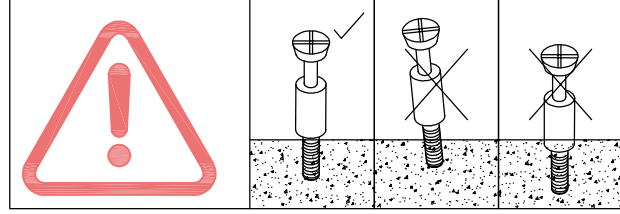
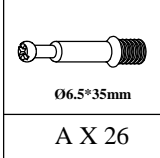
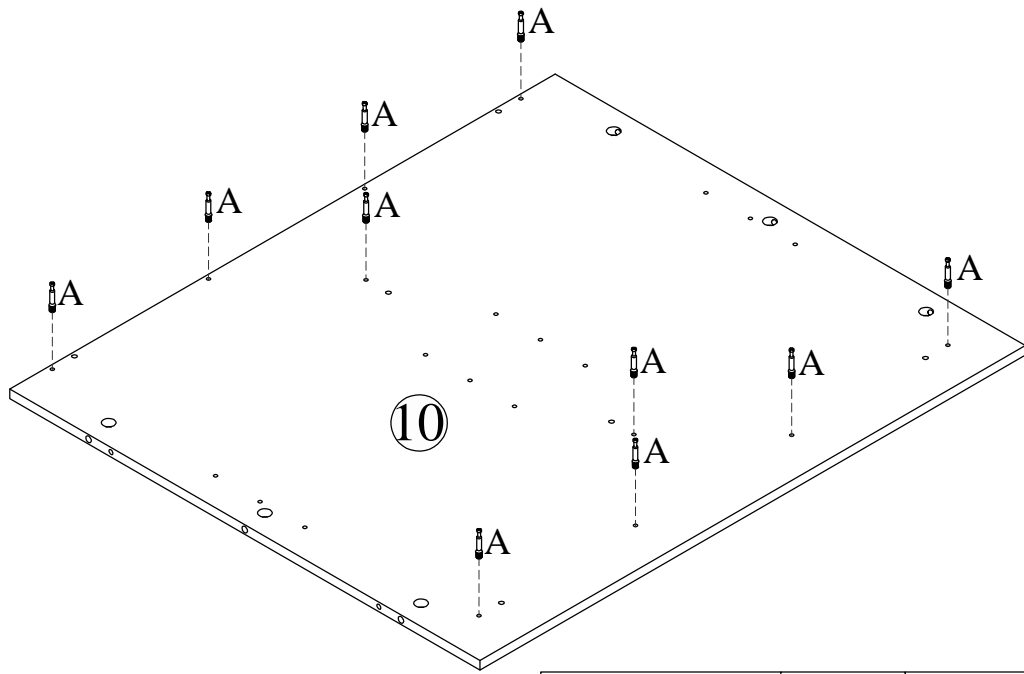
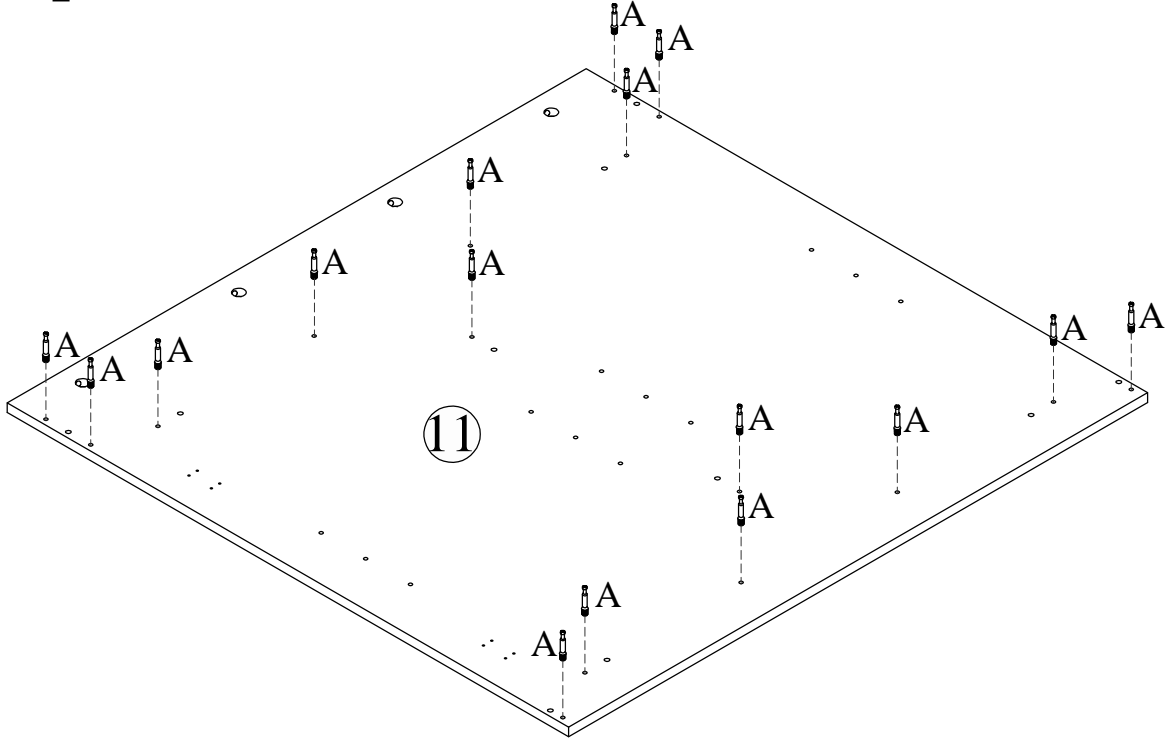

 3*12mm	
J X 6	T X 2

Step 11

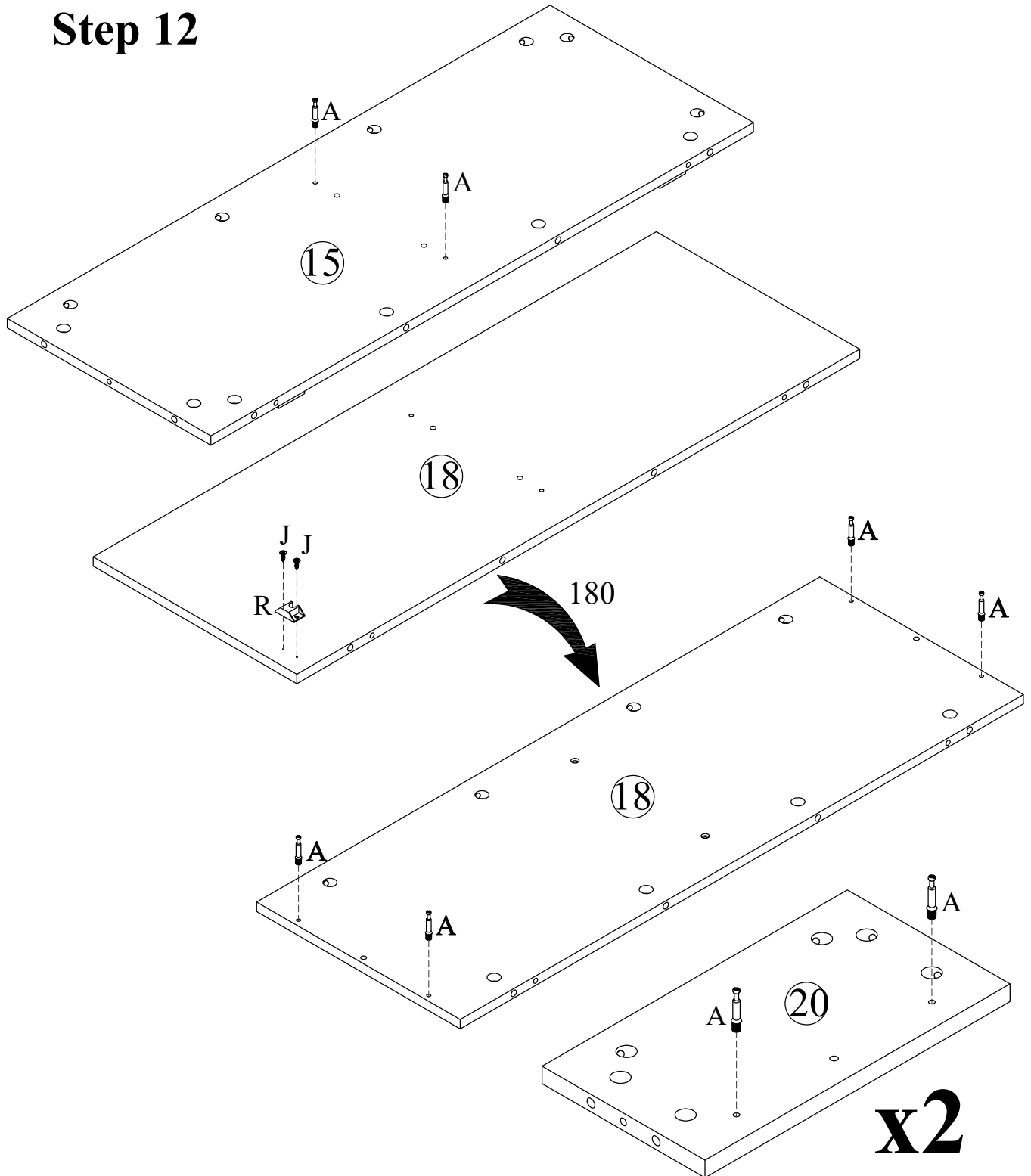

Step 12

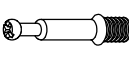

		
Ø6.5*35mm	Ø3*12mm	
A X 10	J X 2	R X 1

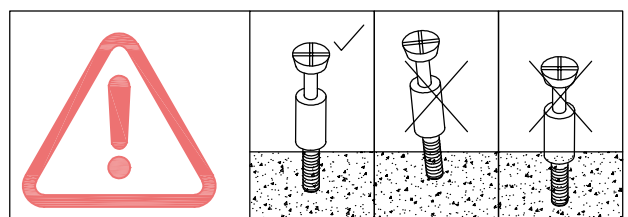

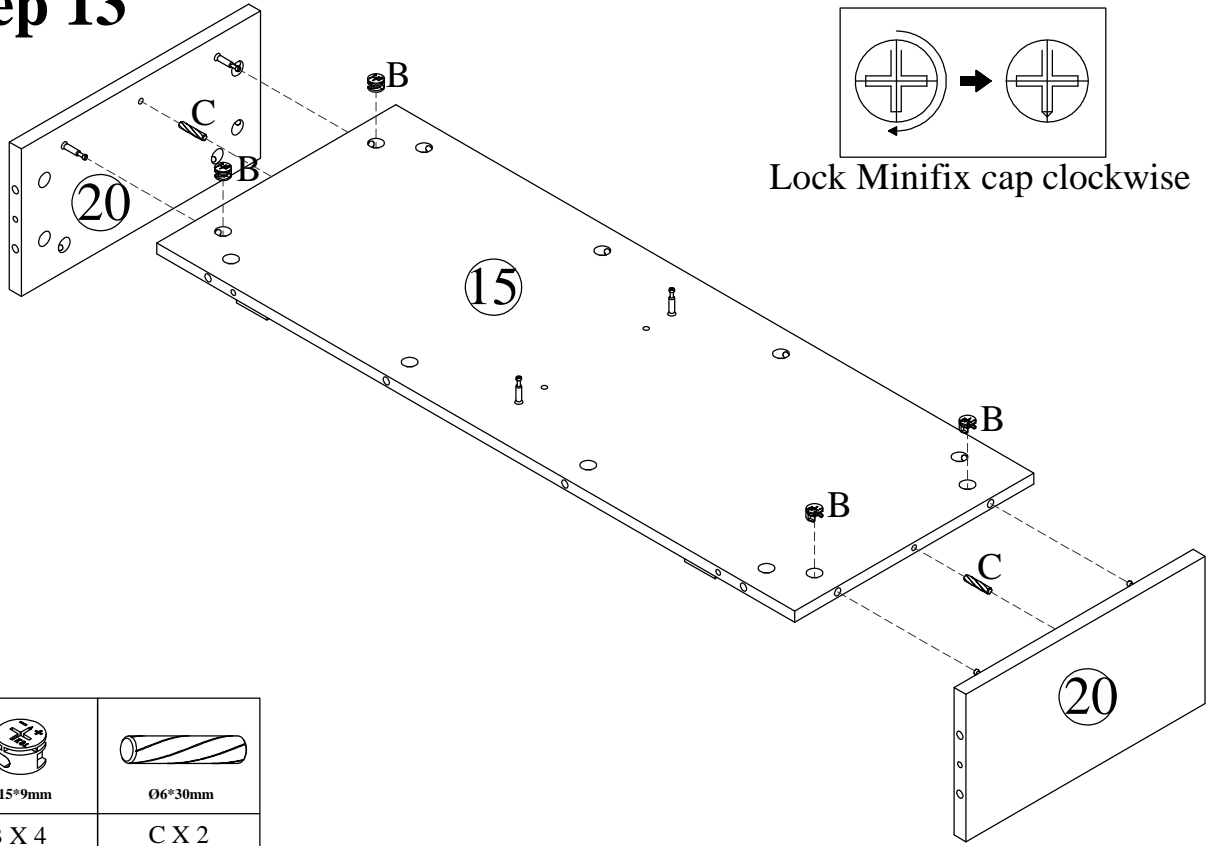

Step 13

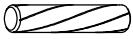

	
Ø15*9mm	Ø6*30mm
B X 4	C X 2

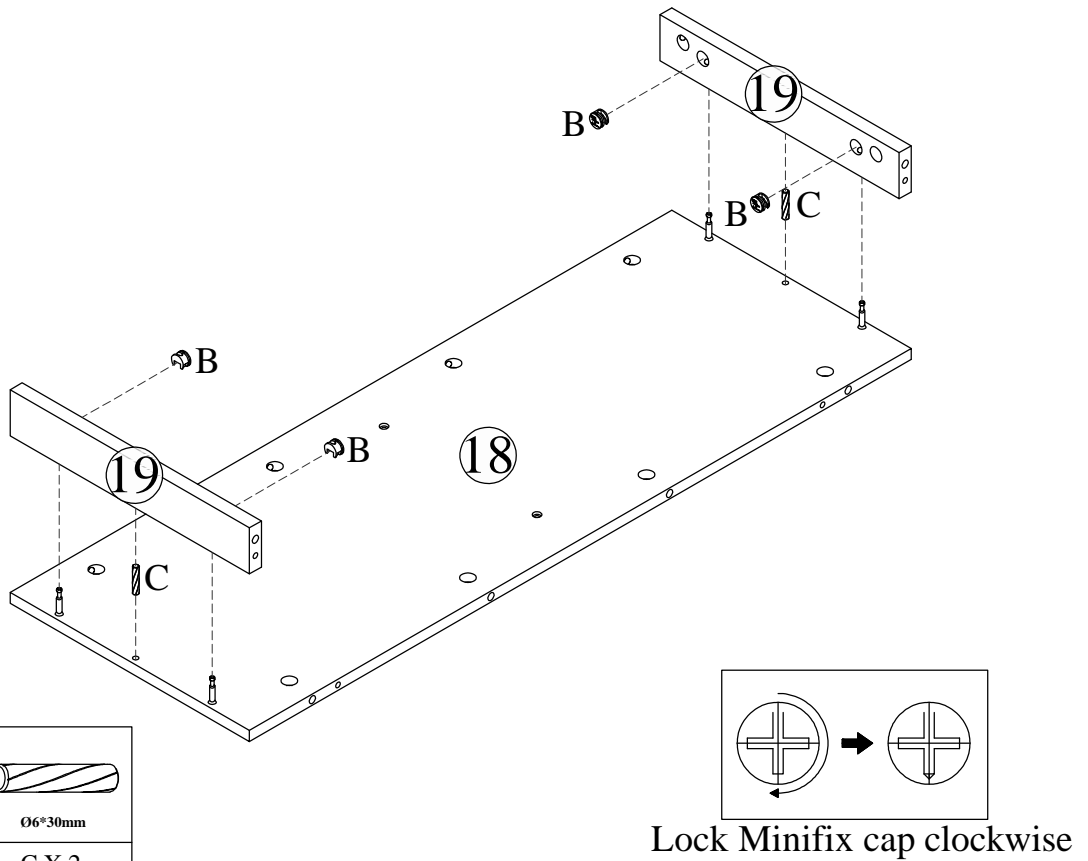
Step 14

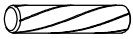

	
Ø15*9mm	Ø6*30mm
B X 4	C X 2

Step 15

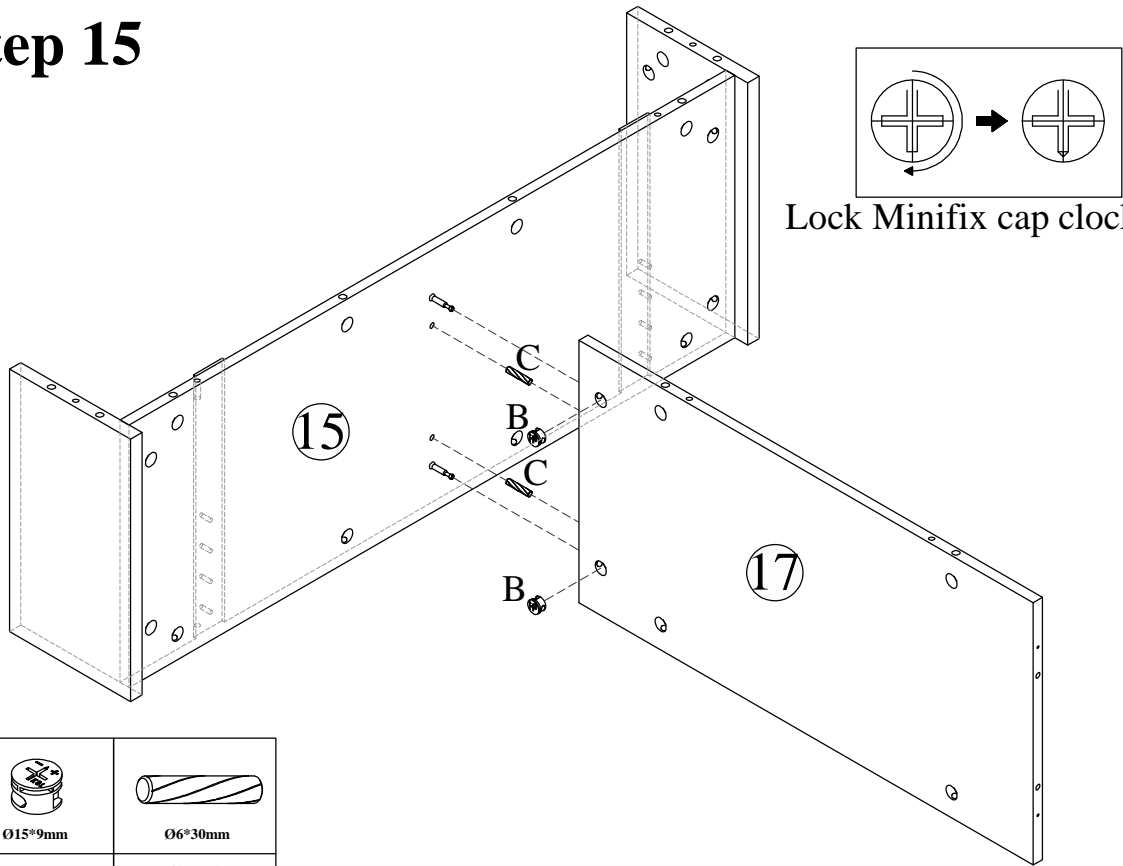

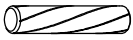

Lock Minifix cap clockwise

	
Ø15*9mm	Ø6*30mm
B X 2	C X 2

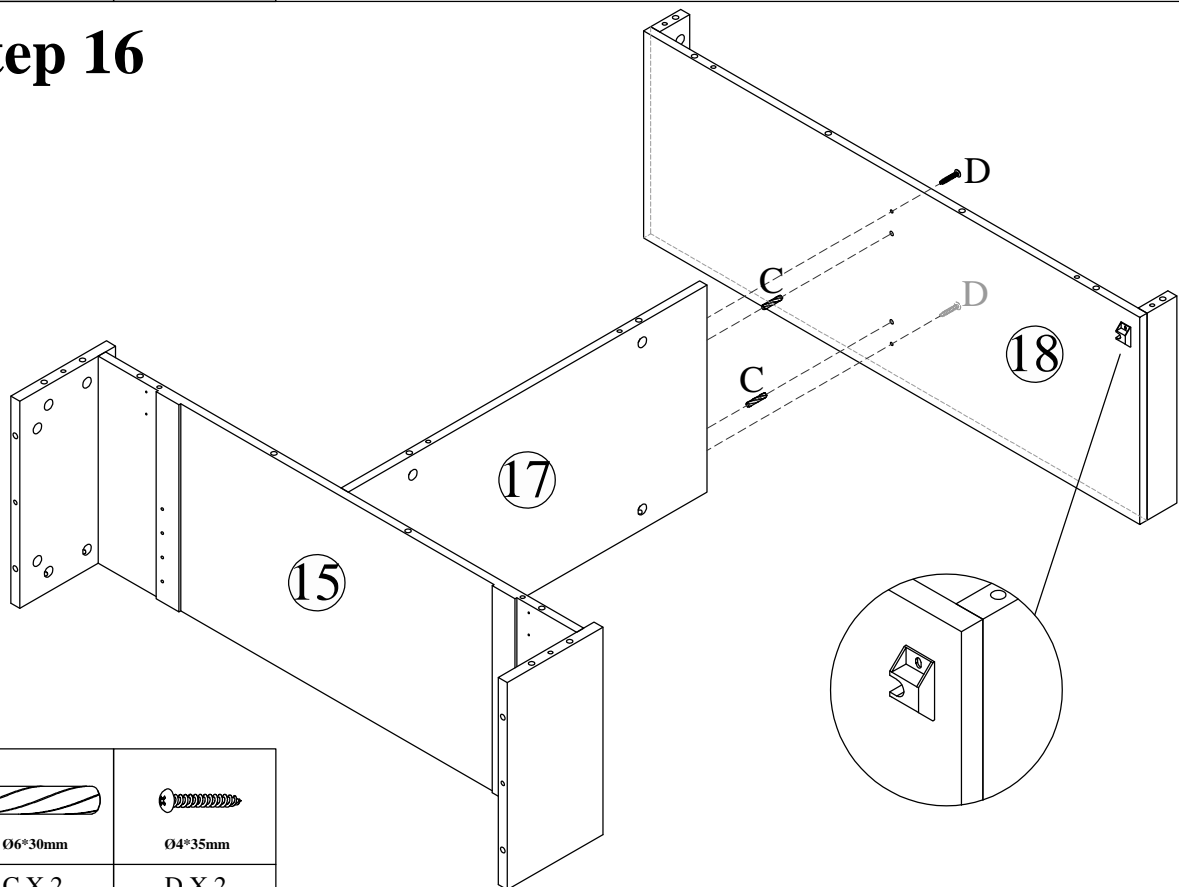
Step 16

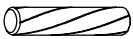

	
Ø6*30mm	Ø4*35mm
C X 2	D X 2

Step 17

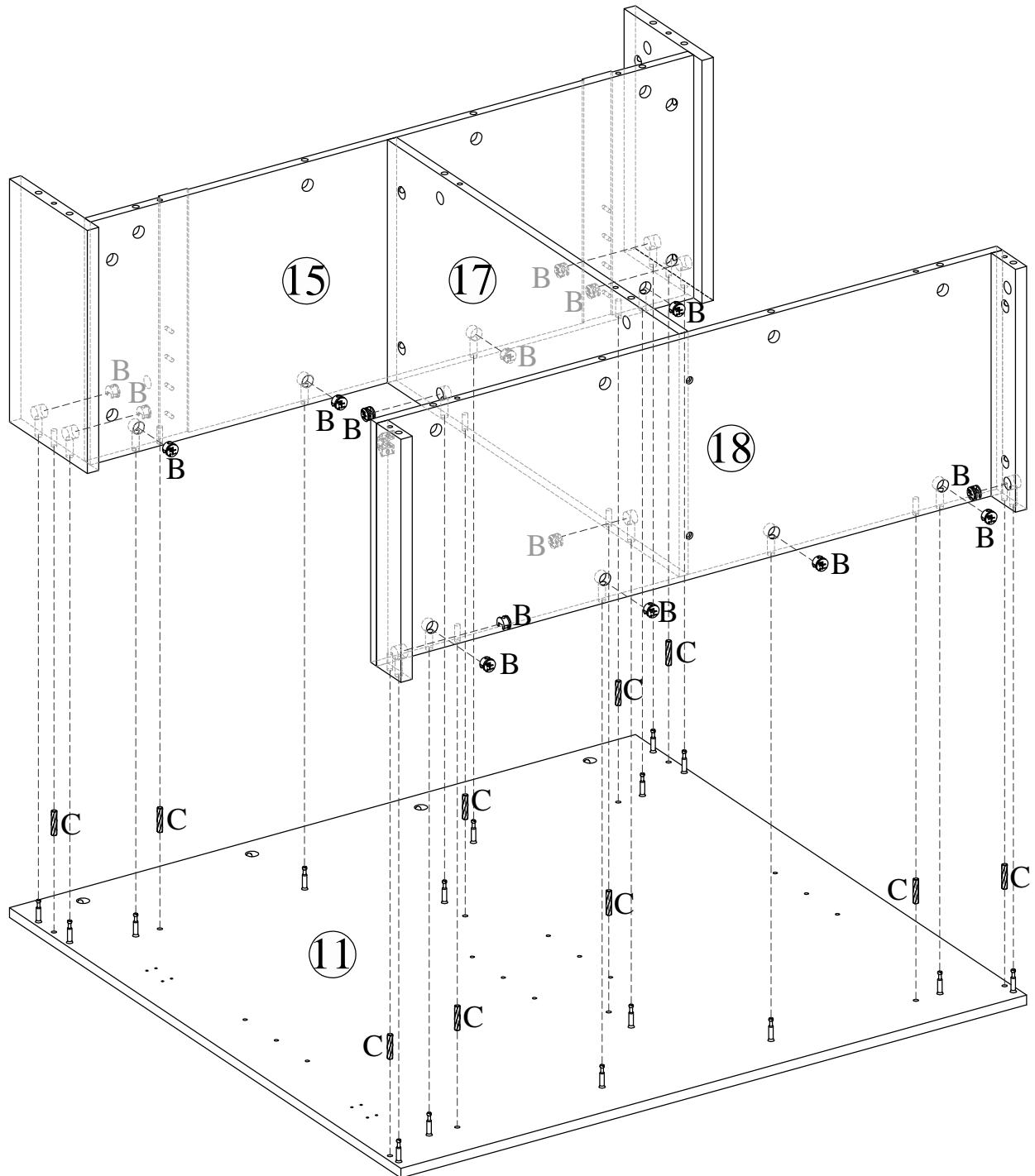

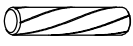
	
Ø15*9mm	Ø6*30mm
B X 16	C X 10

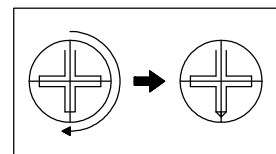

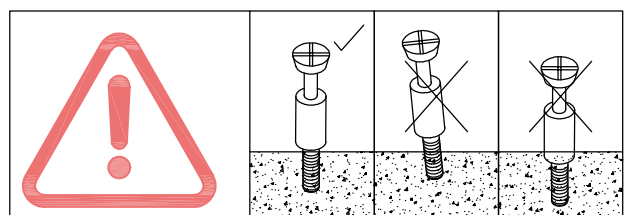
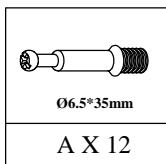
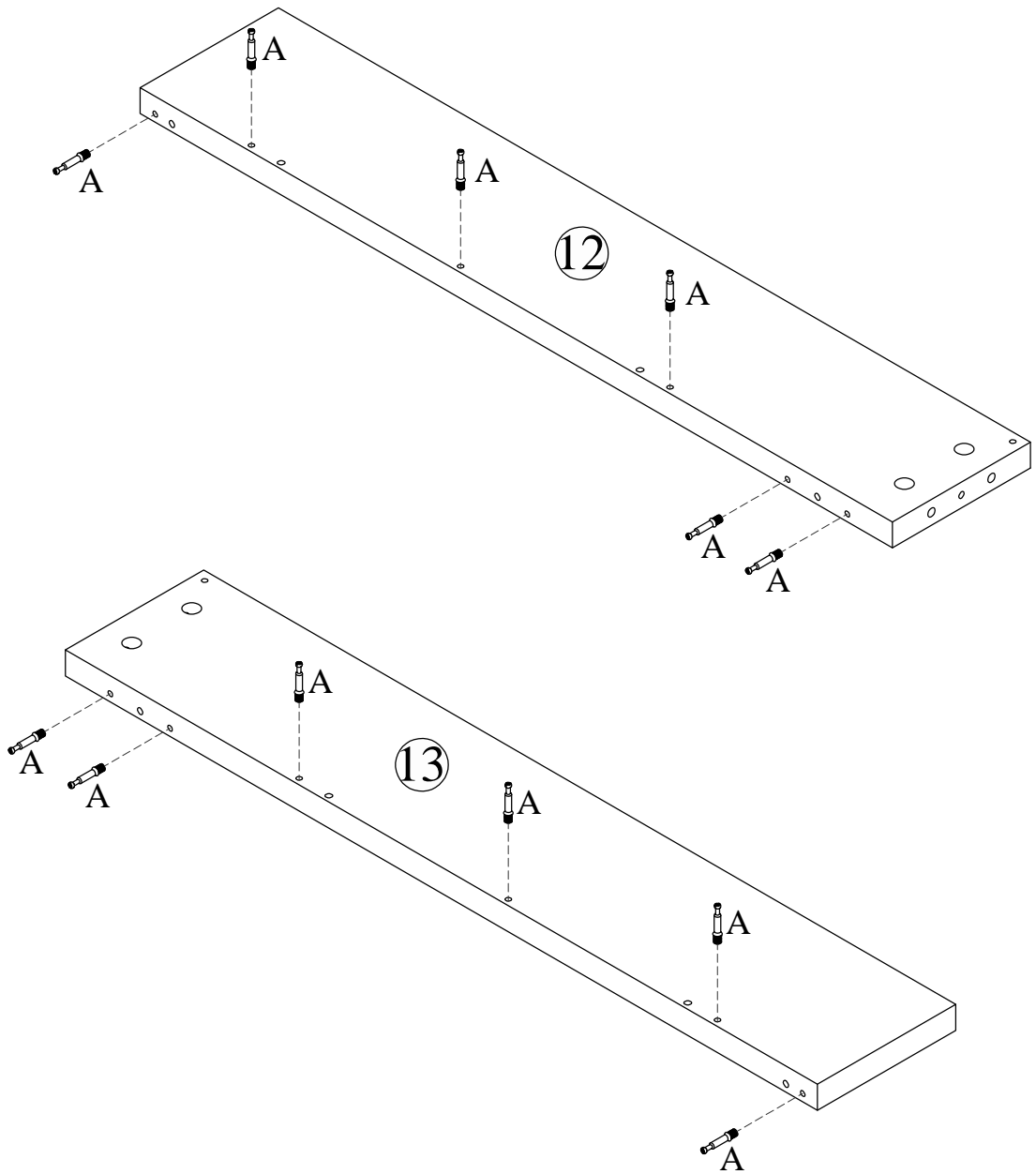

Lock Minifix cap clockwise

Step 18

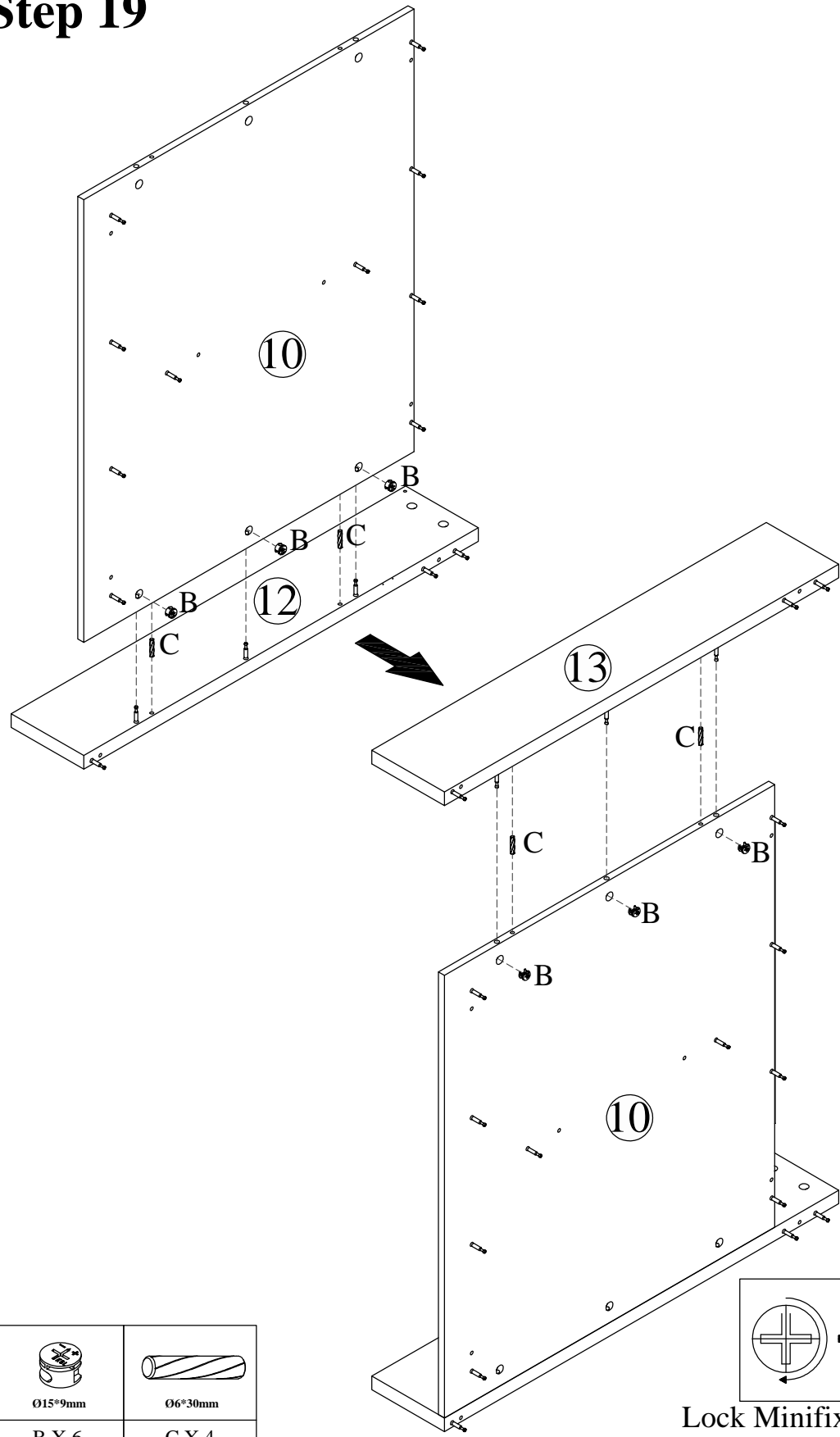

Step 19

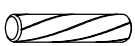

	
Ø15*9mm	Ø6*30mm
B X 6	C X 4

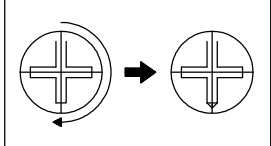
 Lock Minifix cap clockwise

Step 20

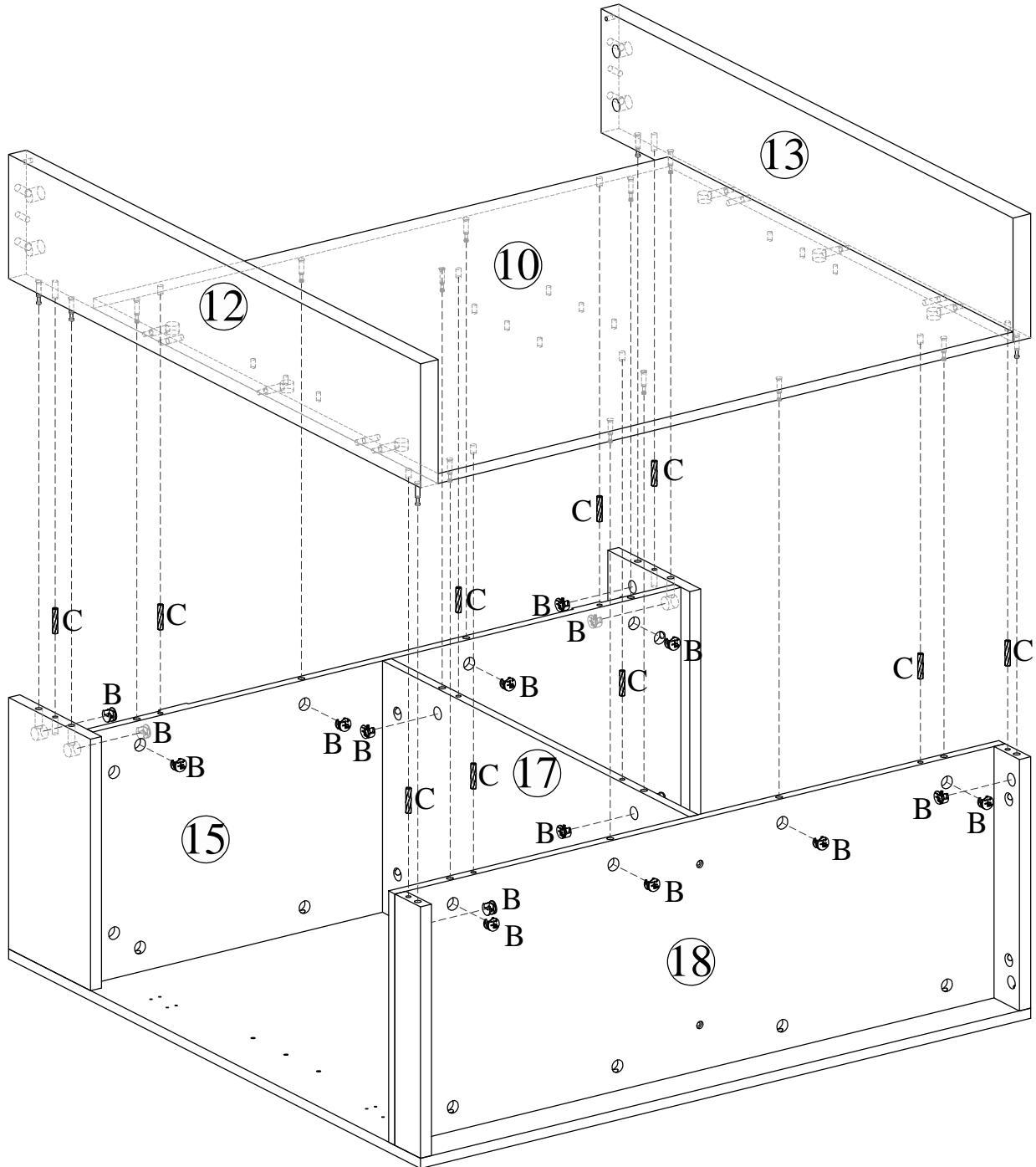

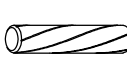
	
Ø15*9mm	Ø6*30mm
B X 16	C X 10

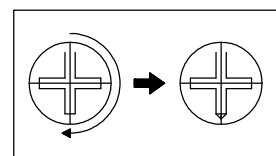

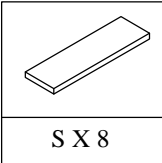
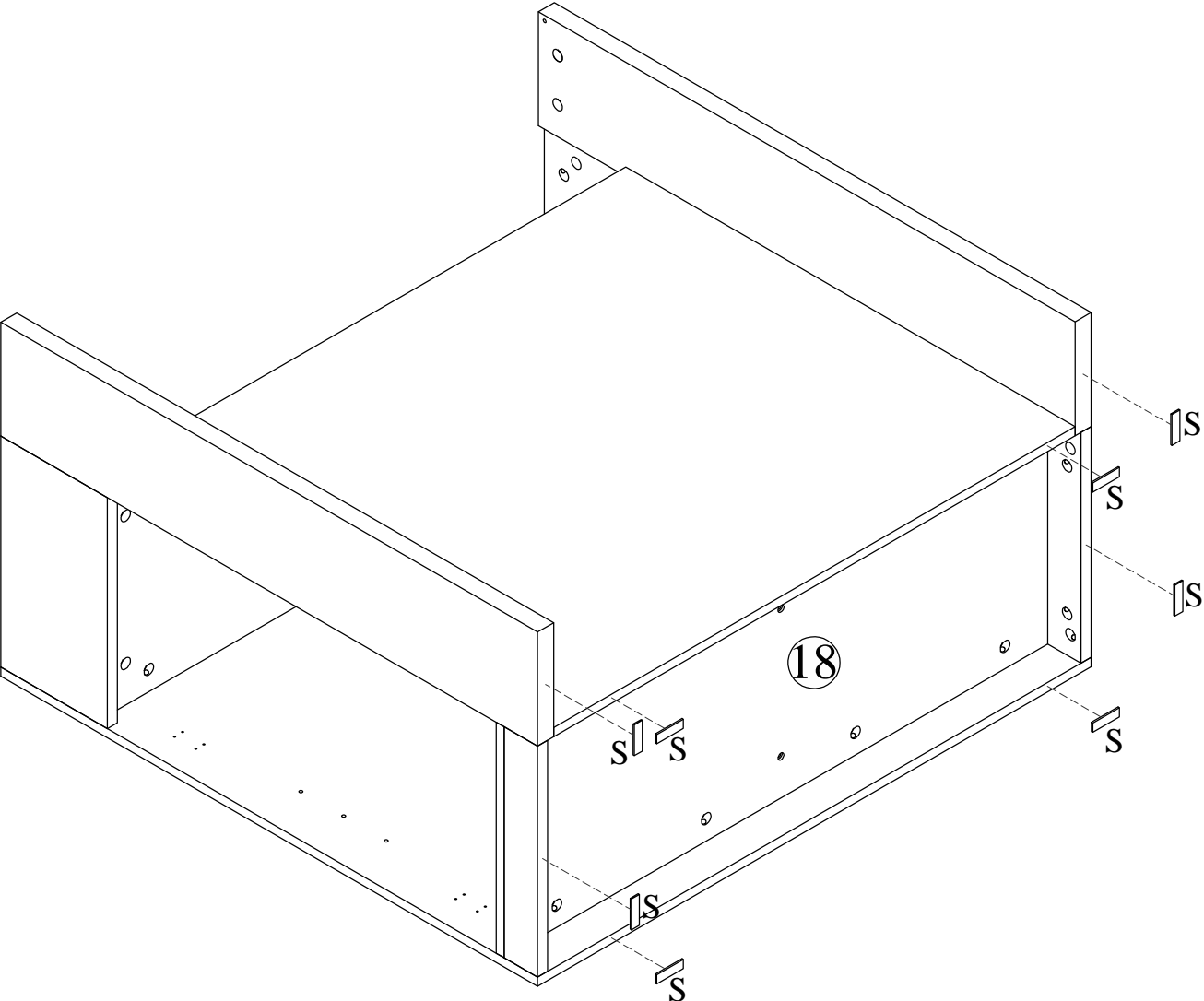

Lock Minifix cap clockwise

Step 21



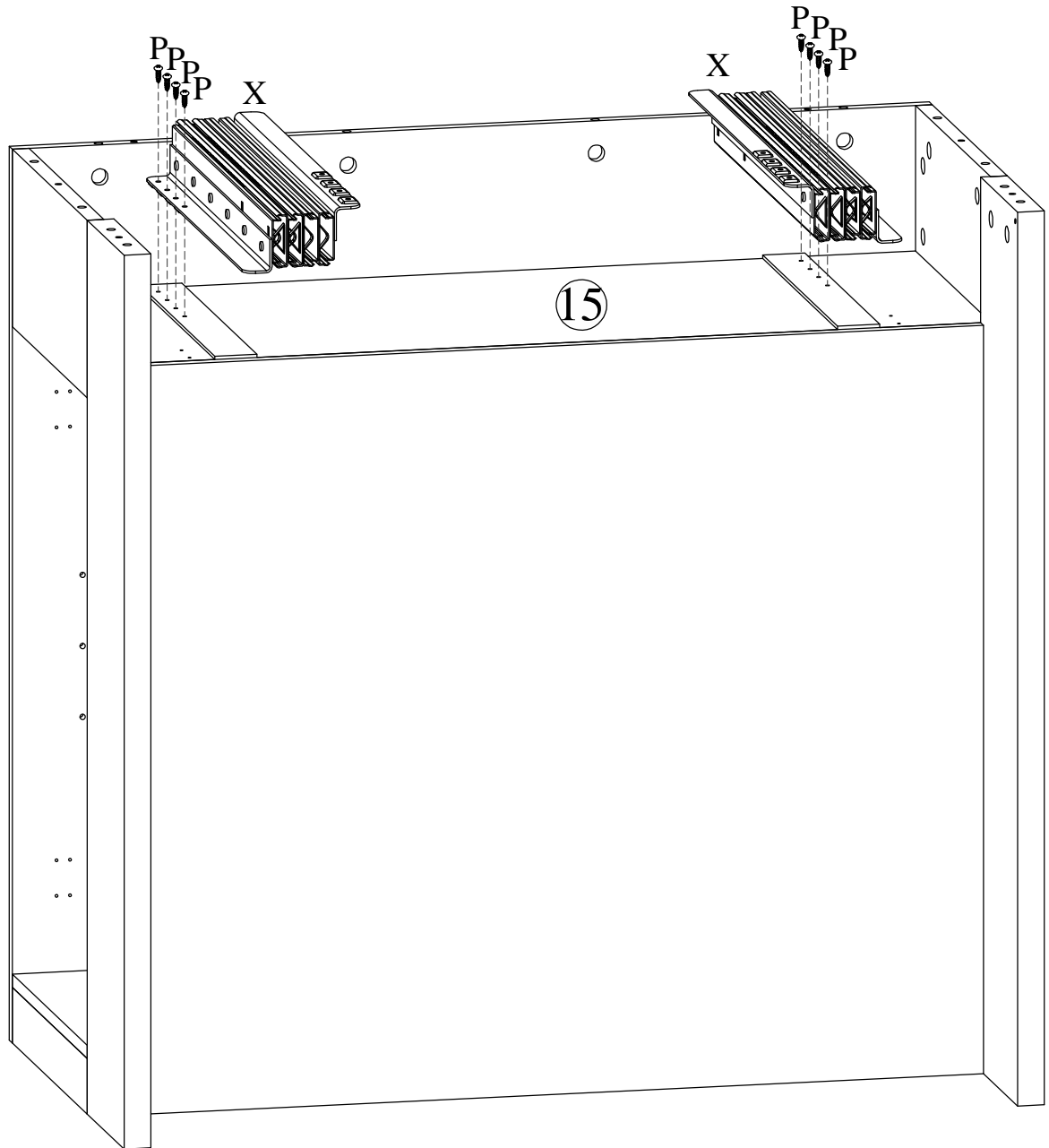

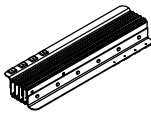

Step 22

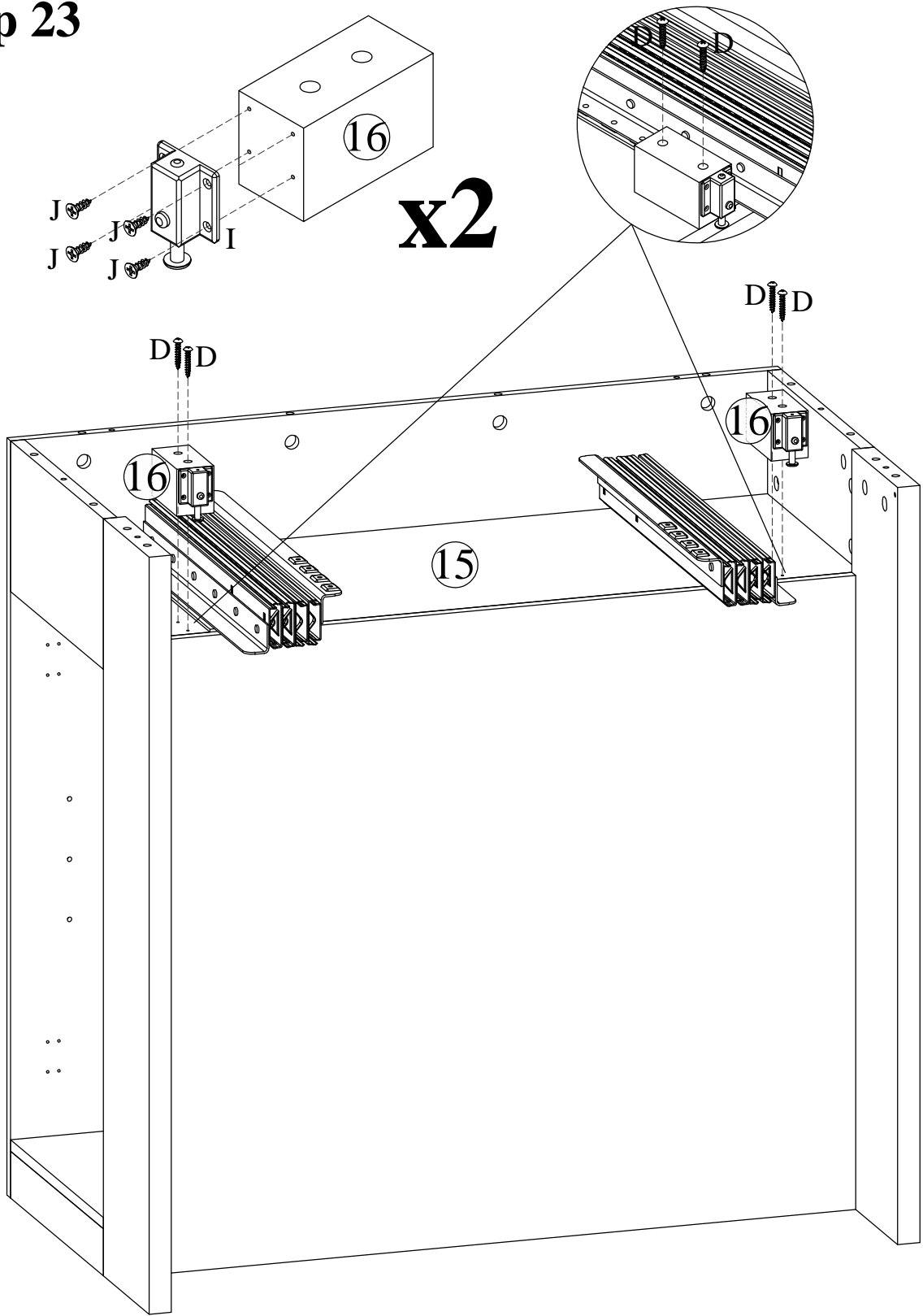

 Ø5*16mm	
P X 8	X X 2

Step 23





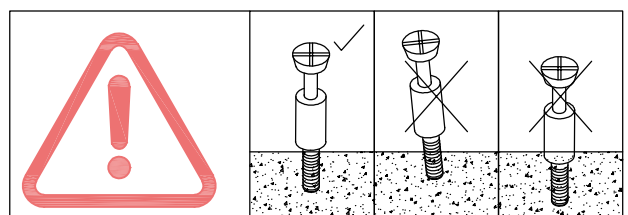
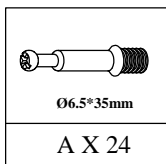
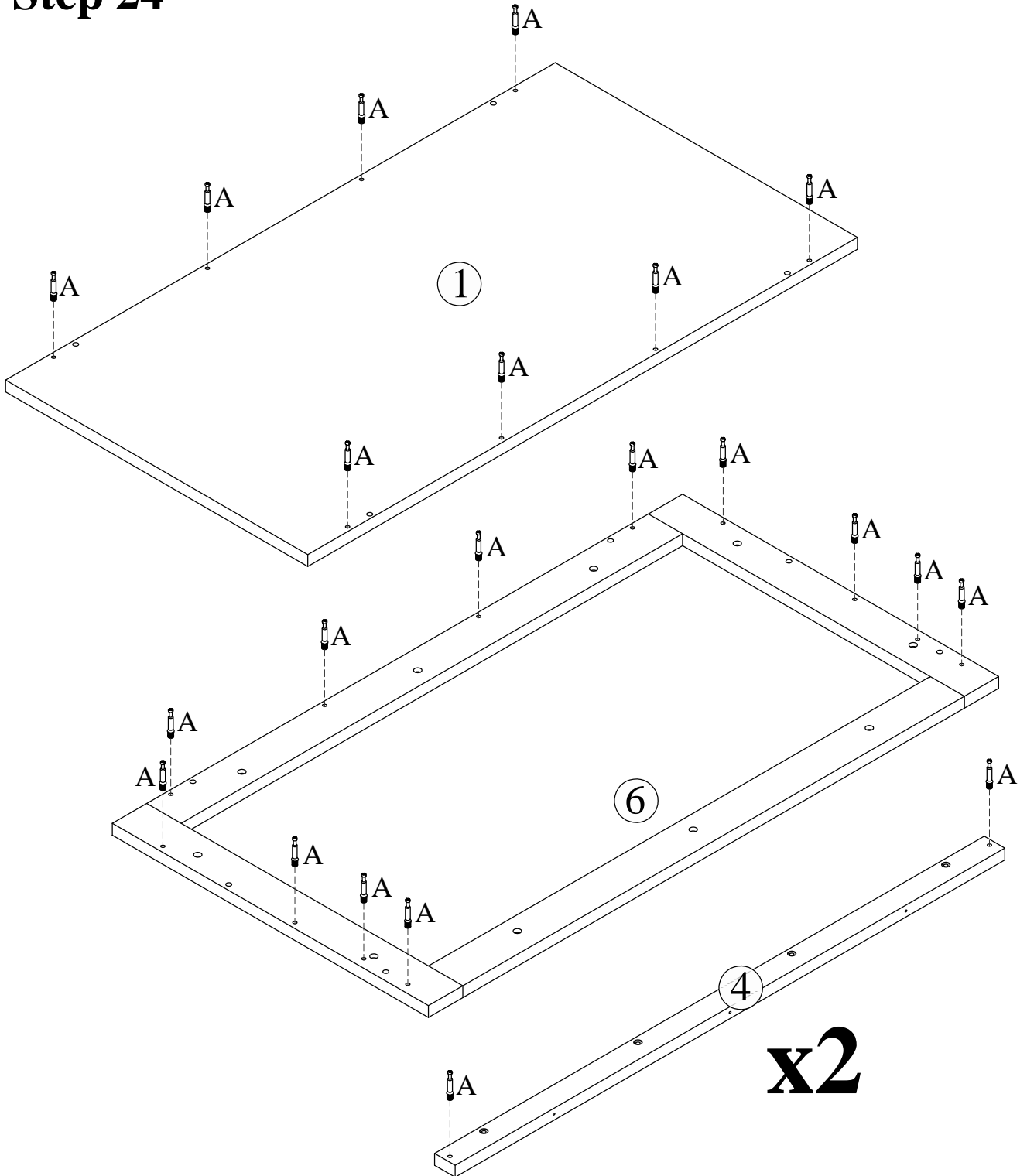

		
Ø4*35mm		Ø3*12mm
D X 4	I X 2	J X 8

Step 24

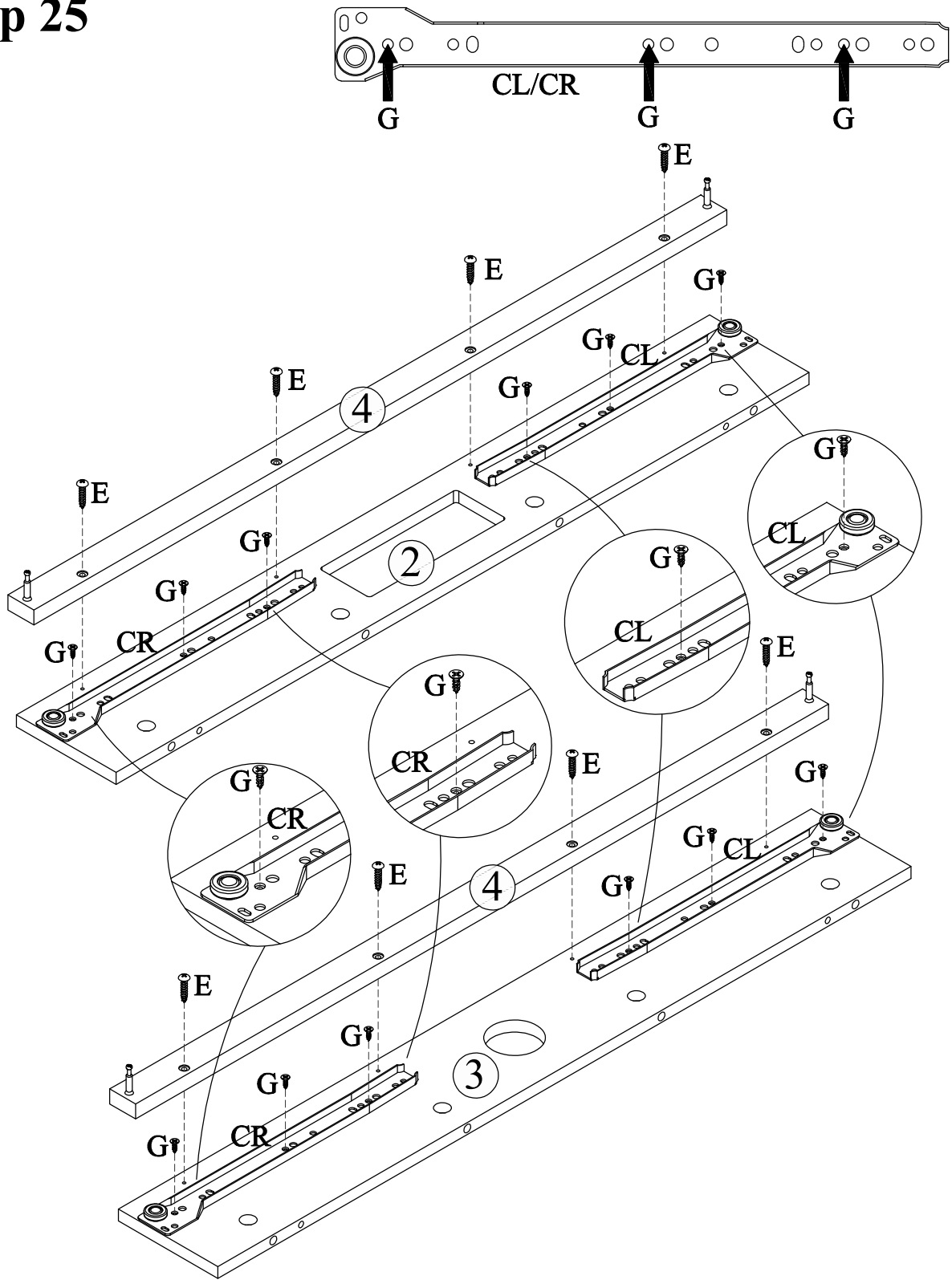



Step 25

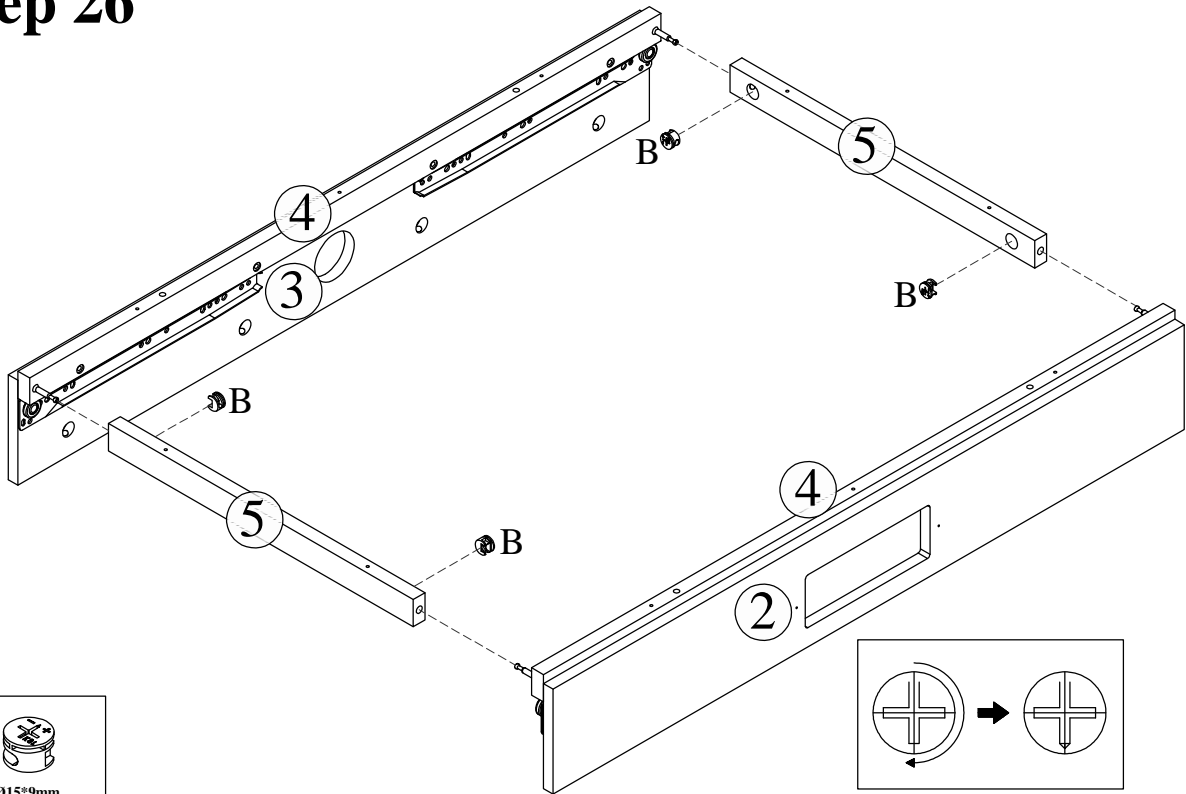

			
Ø4*25mm	Ø4*12mm	300mm	300mm
E X 8	G X 12	CL X 2	CR X 2

Step 26





Ø15*9mm
B X 4

Lock Minifix cap clockwise

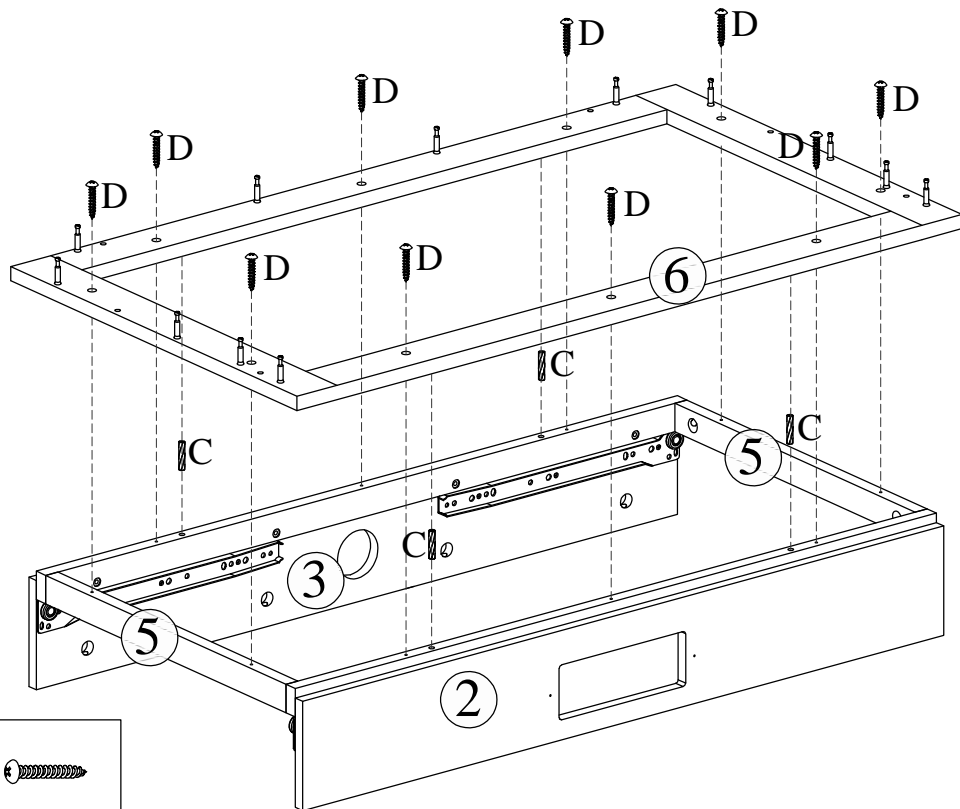
Step 27

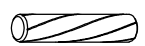

	
Ø6*30mm	Ø4*35mm
C X 4	D X 10

Step 28

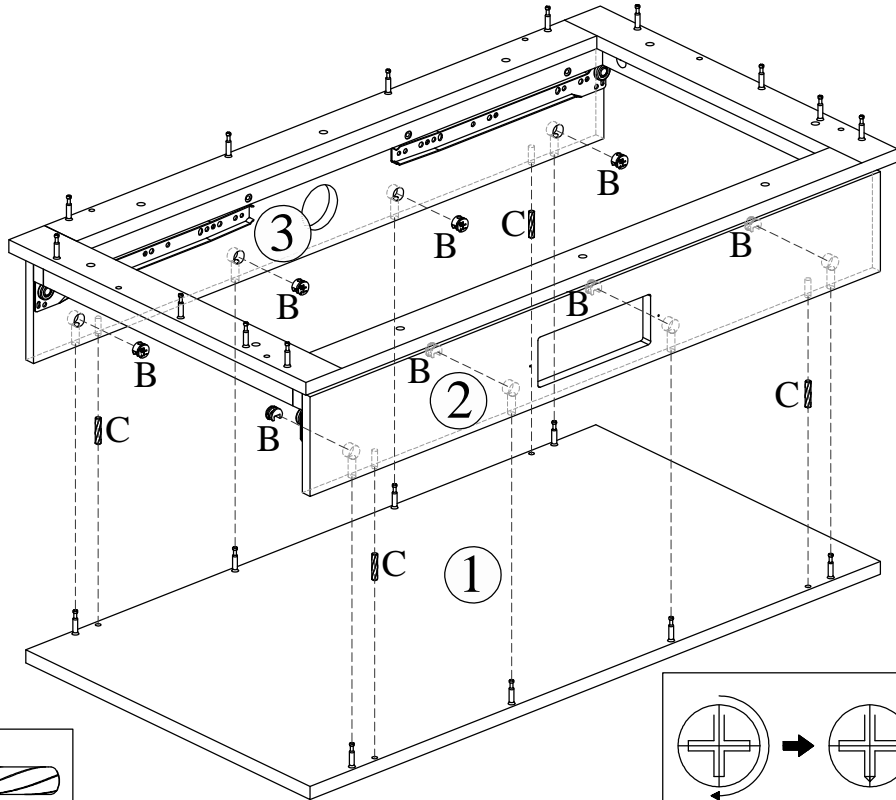

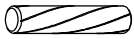

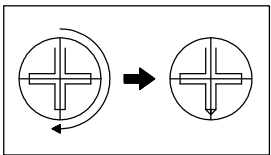
	
Ø15*9mm	Ø6*30mm
B X 8	C X 4

 Lock Minifix cap clockwise

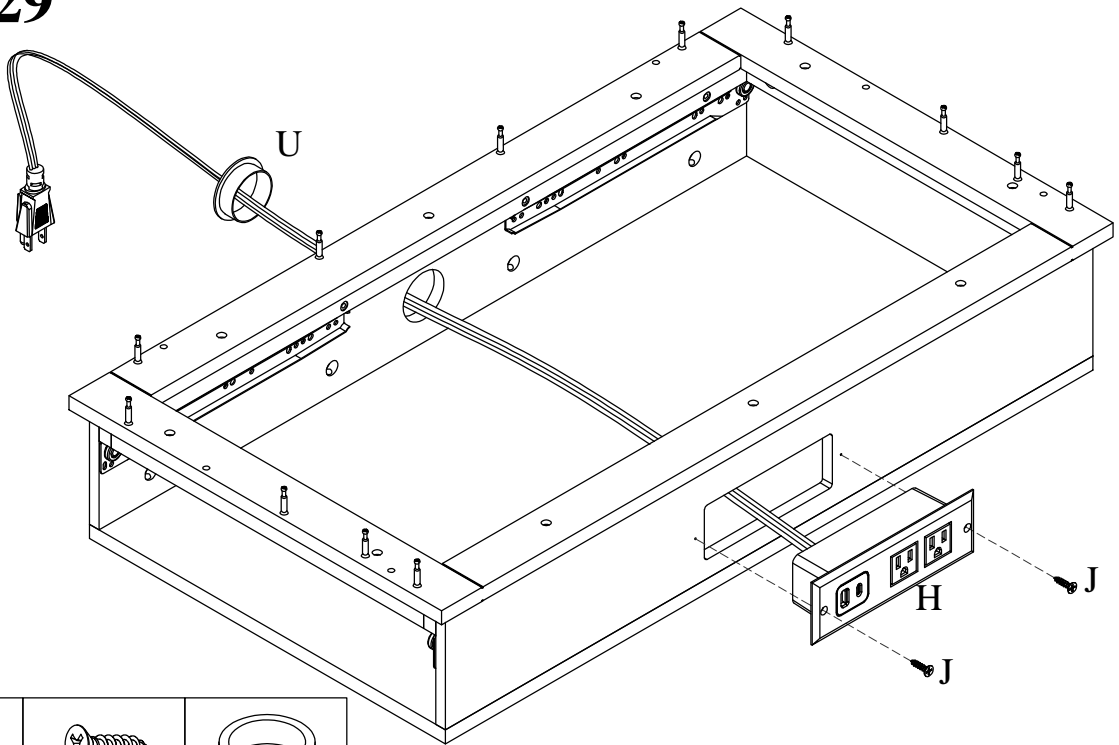
Step 29



		
H X 1	J X 2	U X 1

Step 30

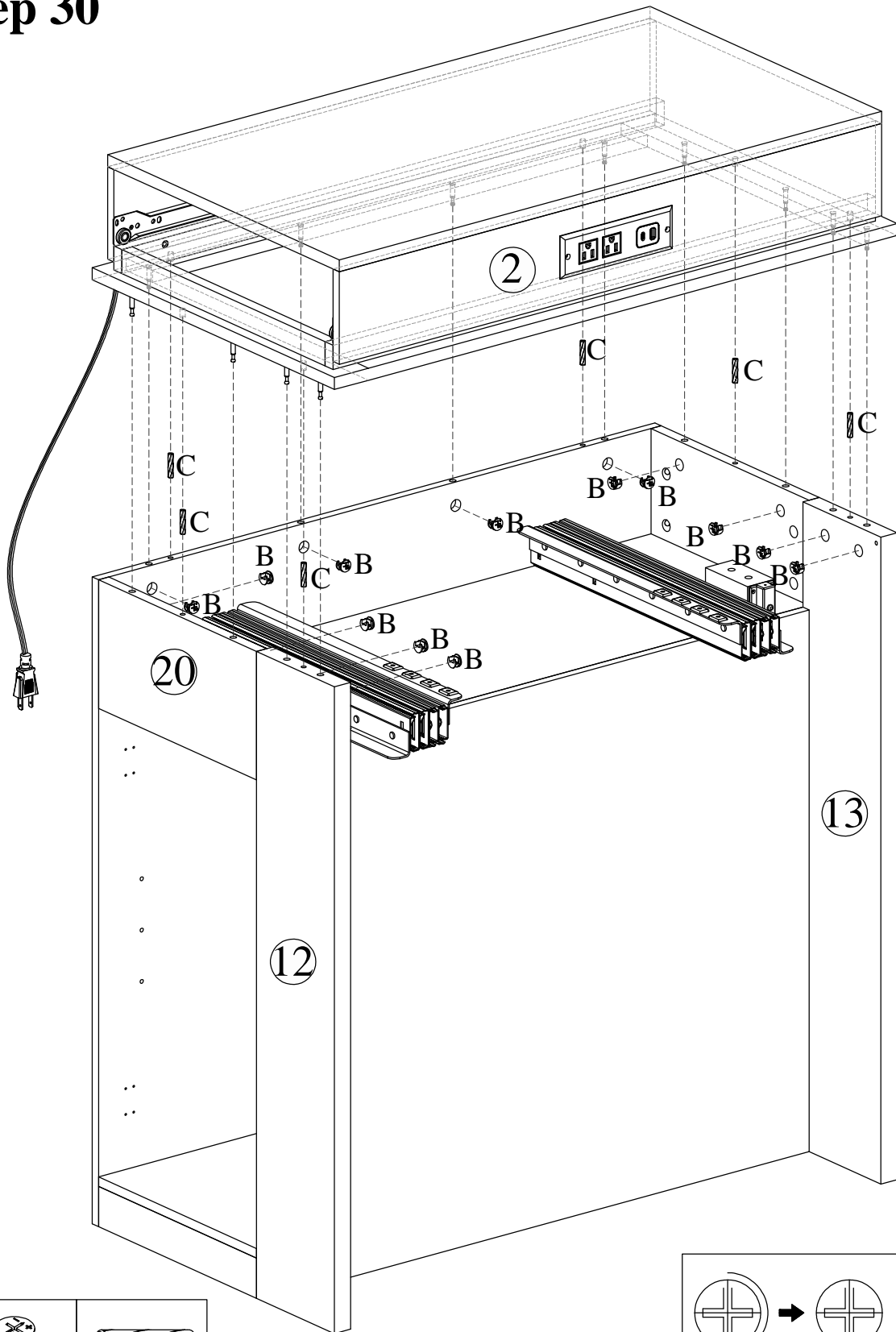

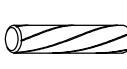
	
Ø15*9mm	Ø6*30mm
B X 12	C X 6

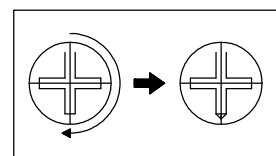



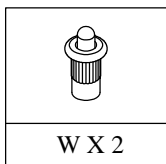
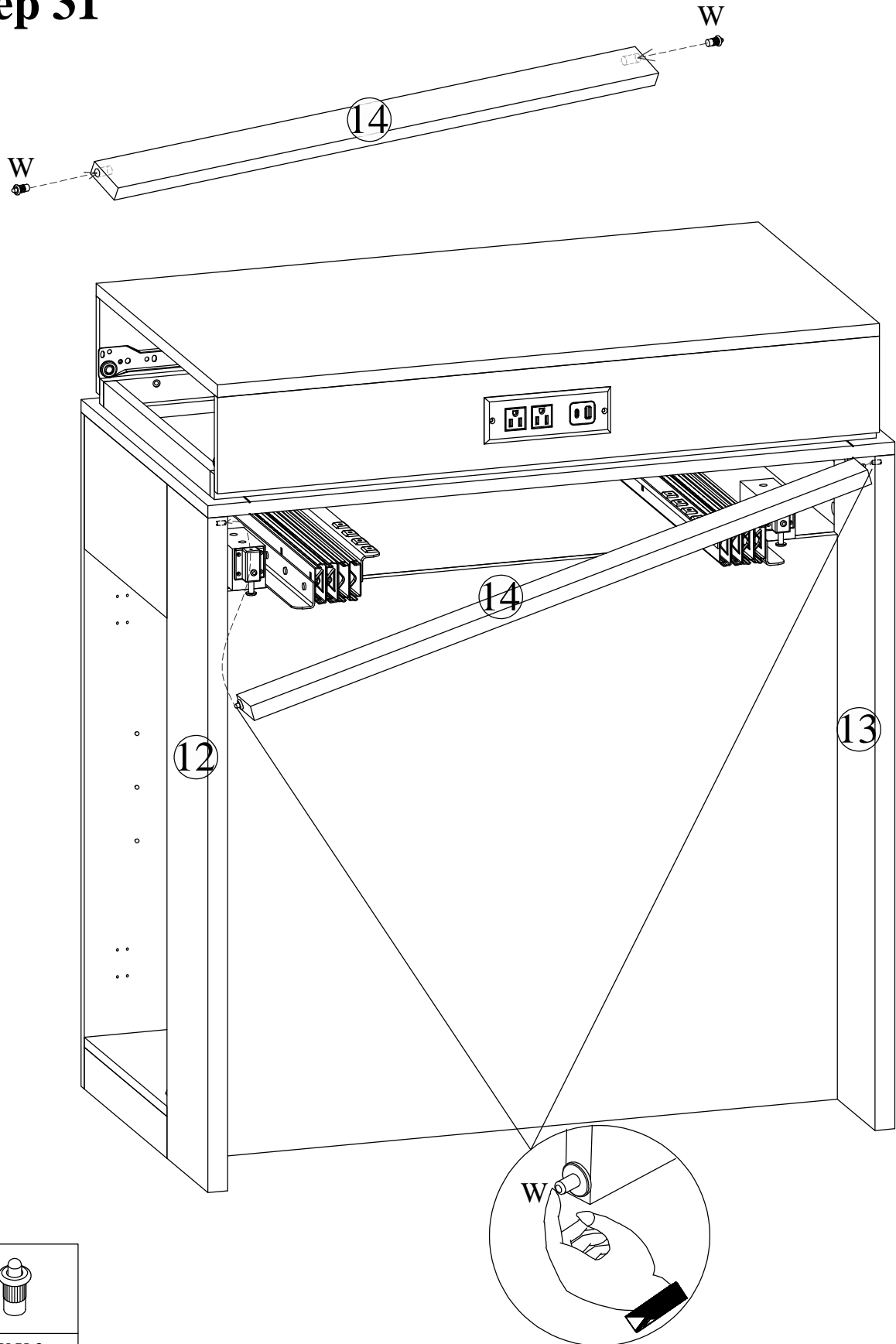

Lock Minifix cap clockwise

Step 31

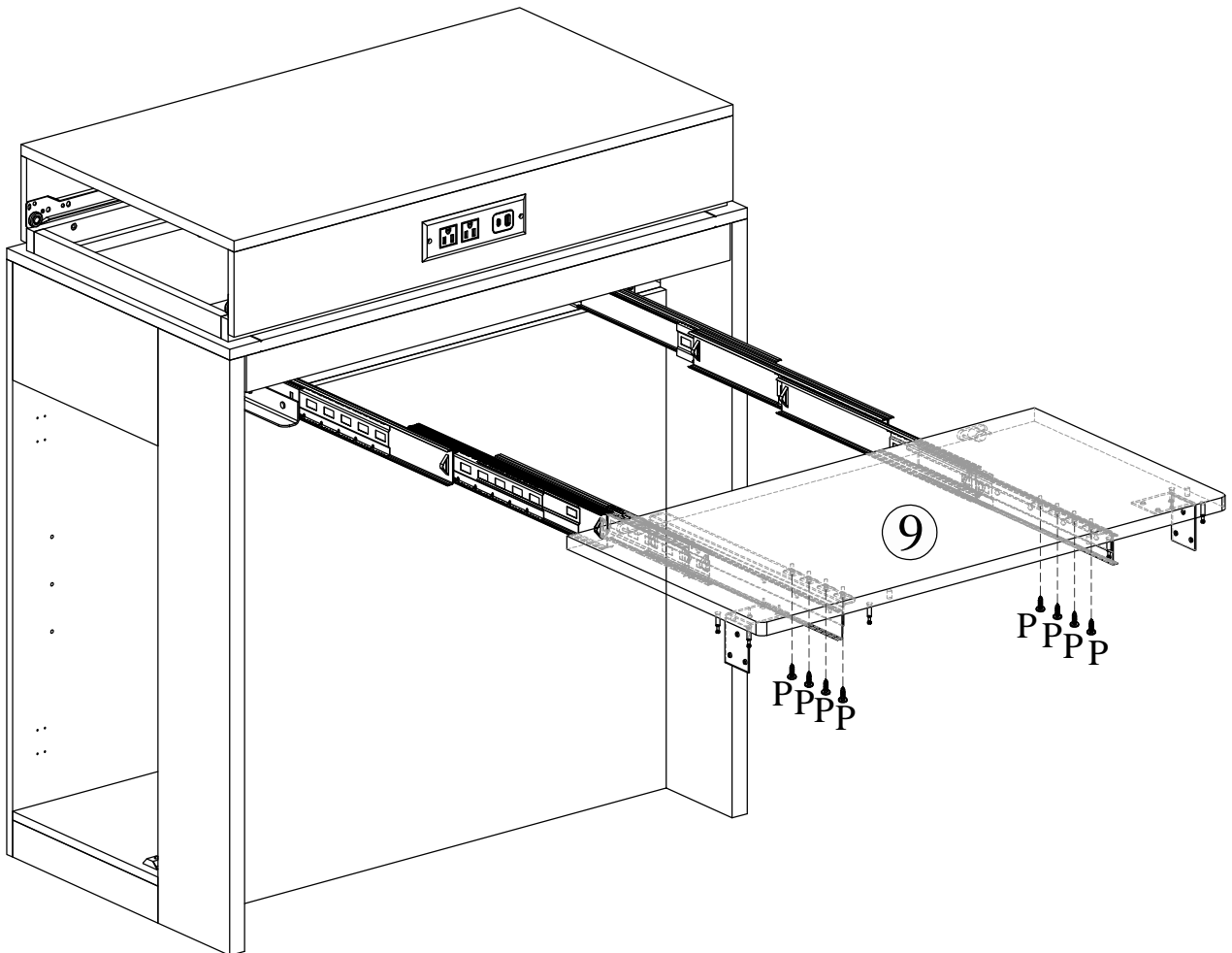
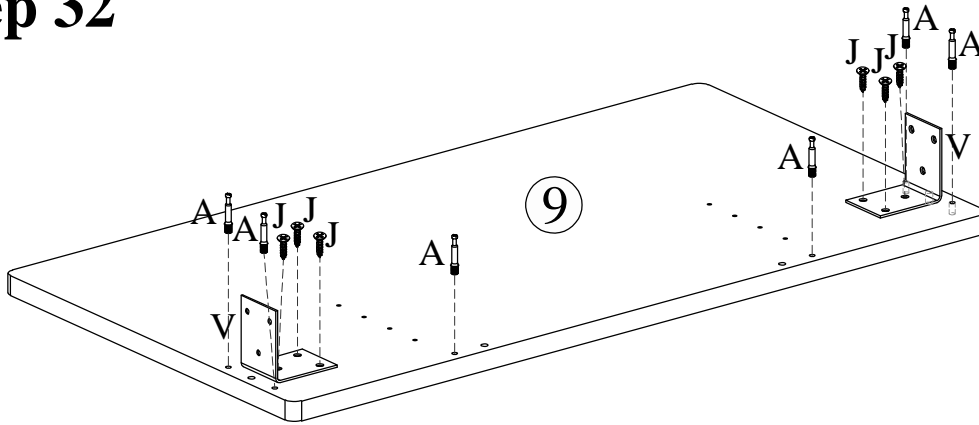

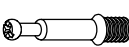
Step 32



			
Ø6.5*35mm	Ø3*12mm	Ø5*16mm	
A X 6	J X 6	P X 8	V X 2

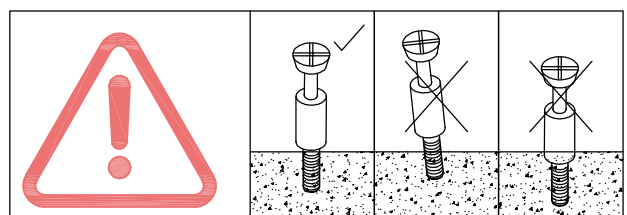

Step 33

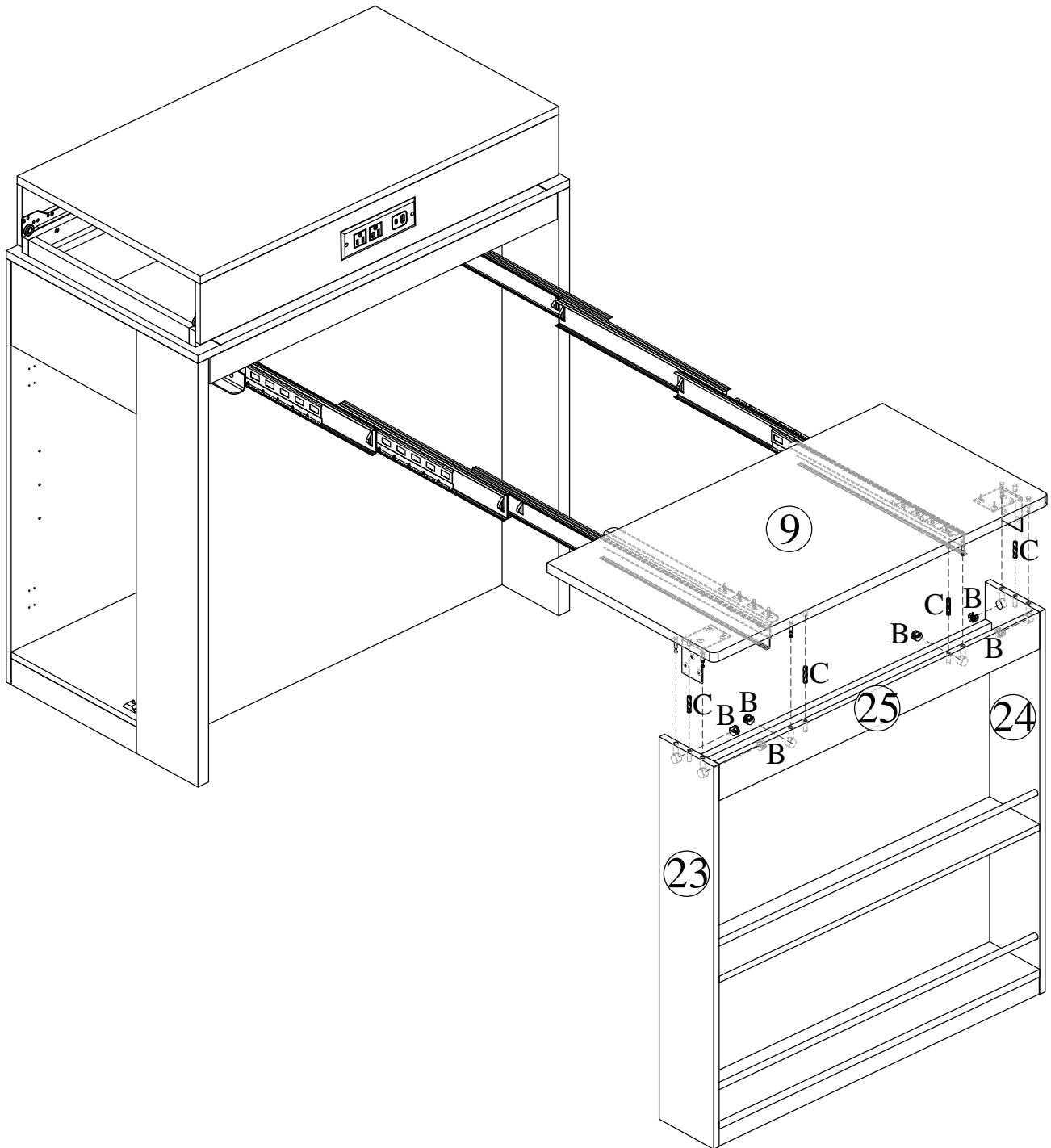

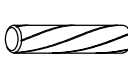
	
Ø15*9mm	Ø6*30mm
B X 6	C X 4

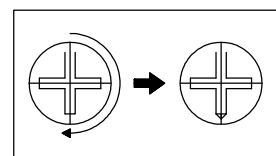

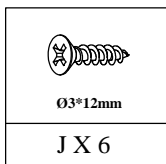
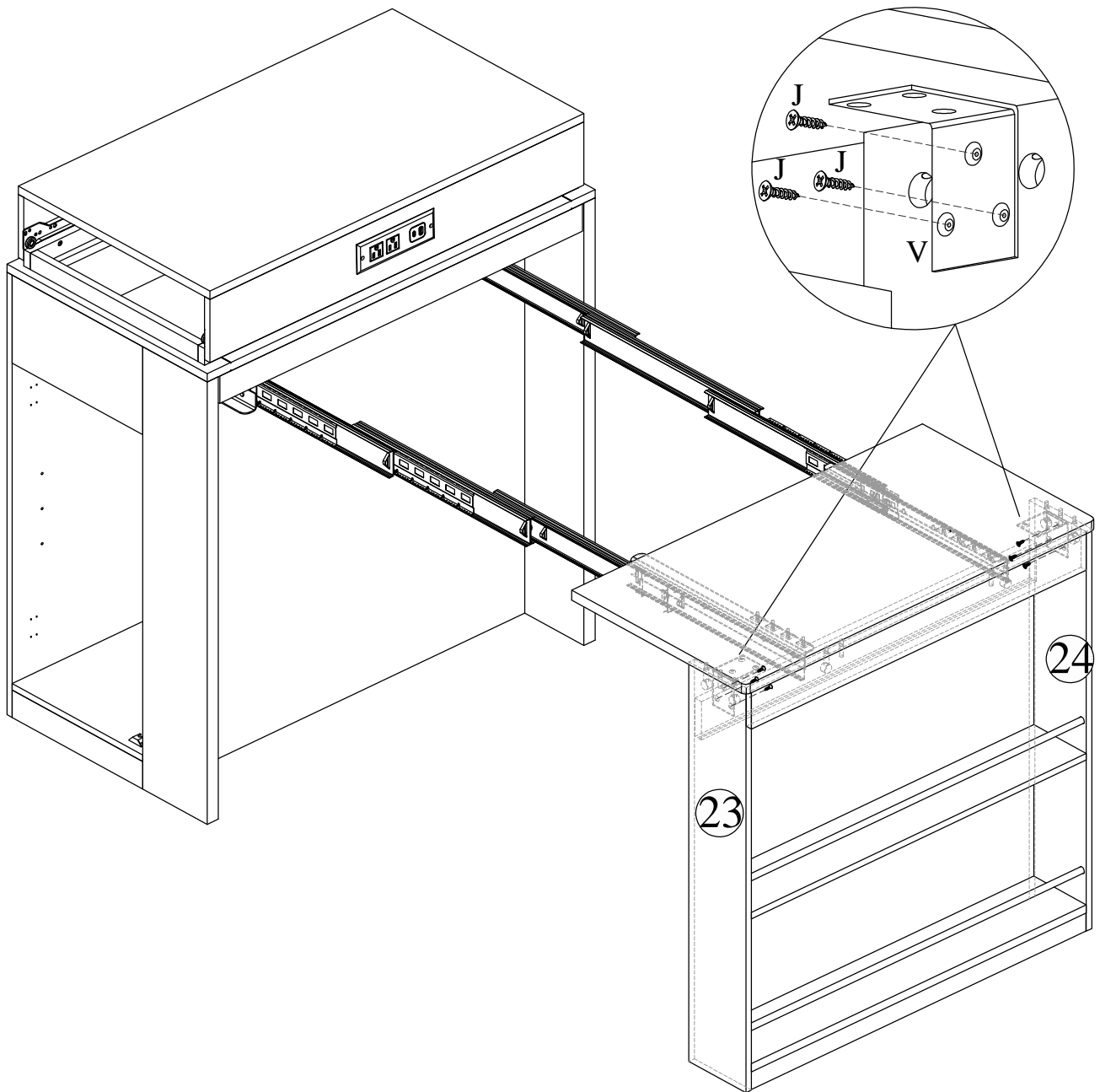

Lock Minifix cap clockwise

Step 34

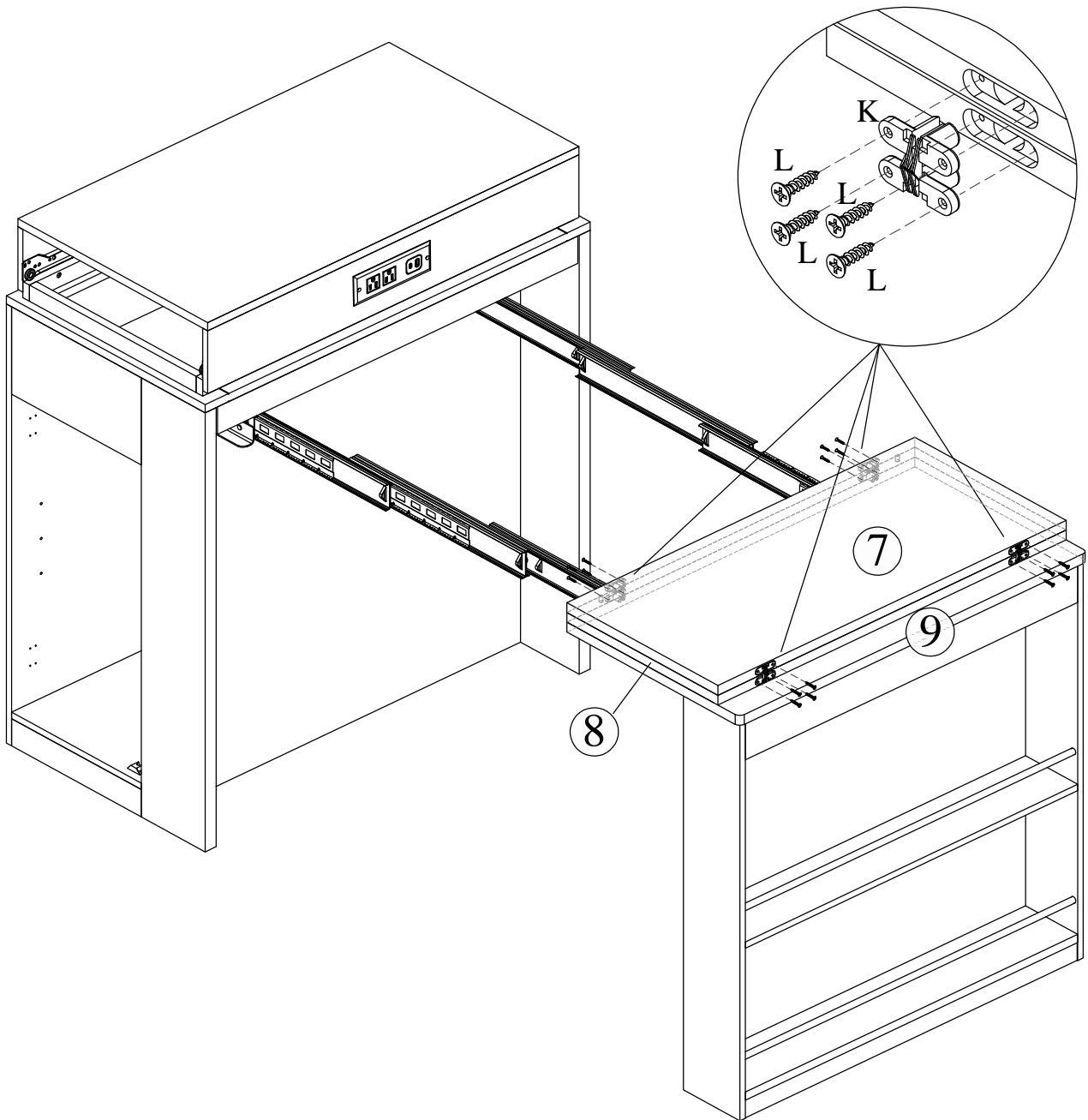

Step 35



	
K X 4	04*19mm L X 16

Step 36

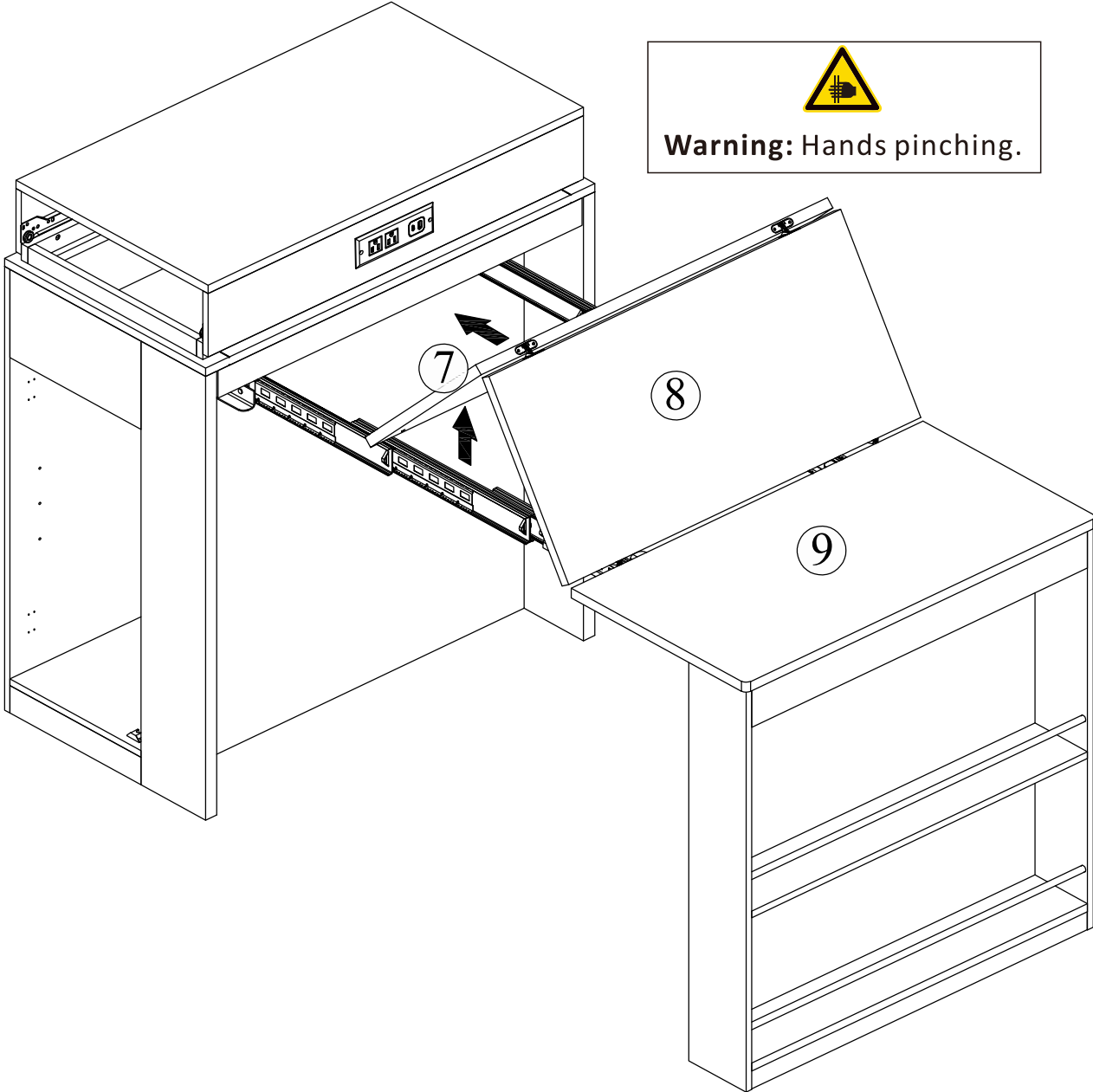

Step 37

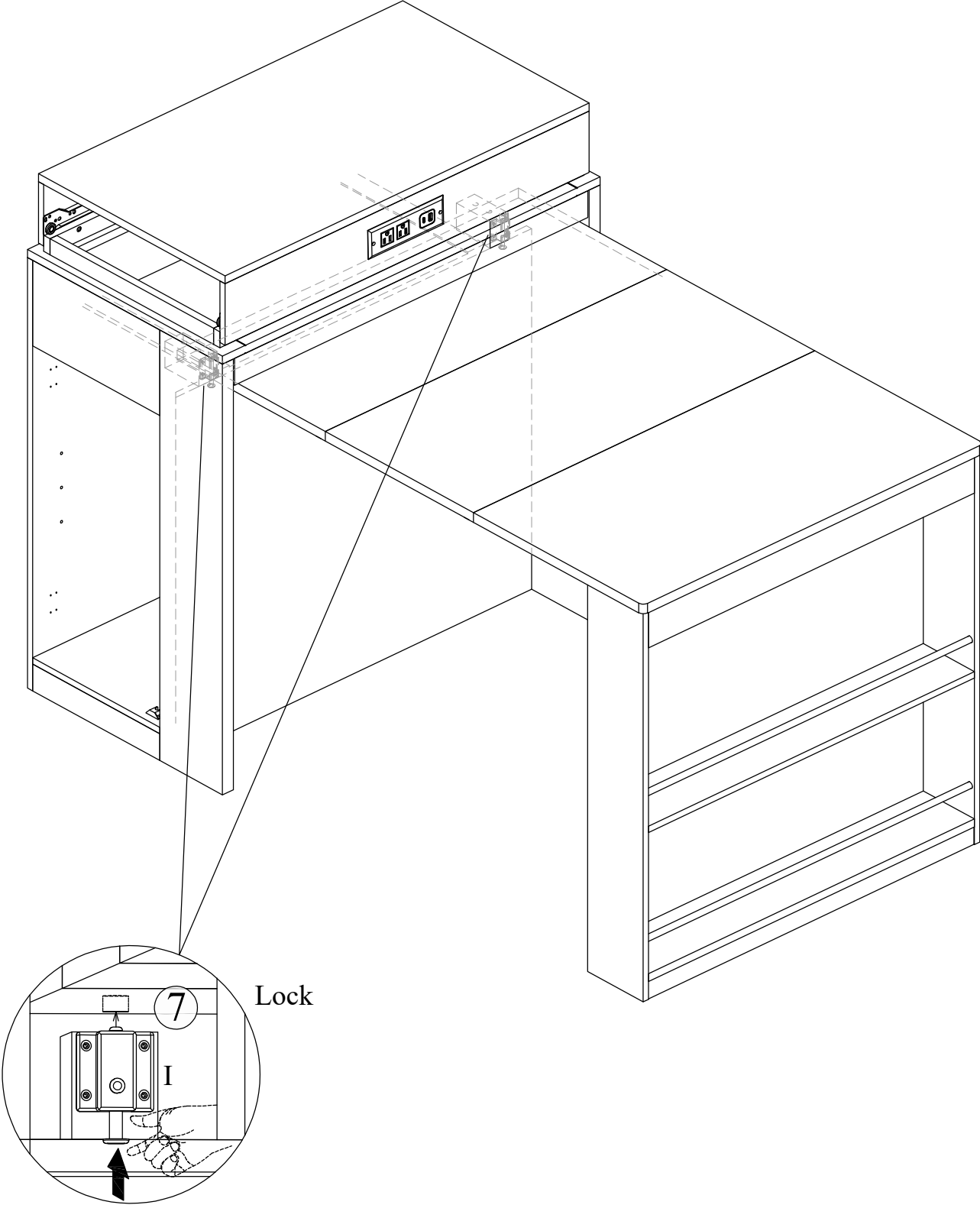

Step 38

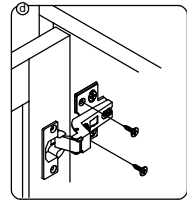
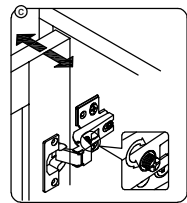
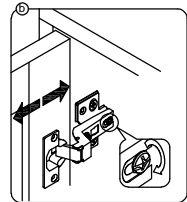
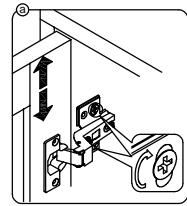
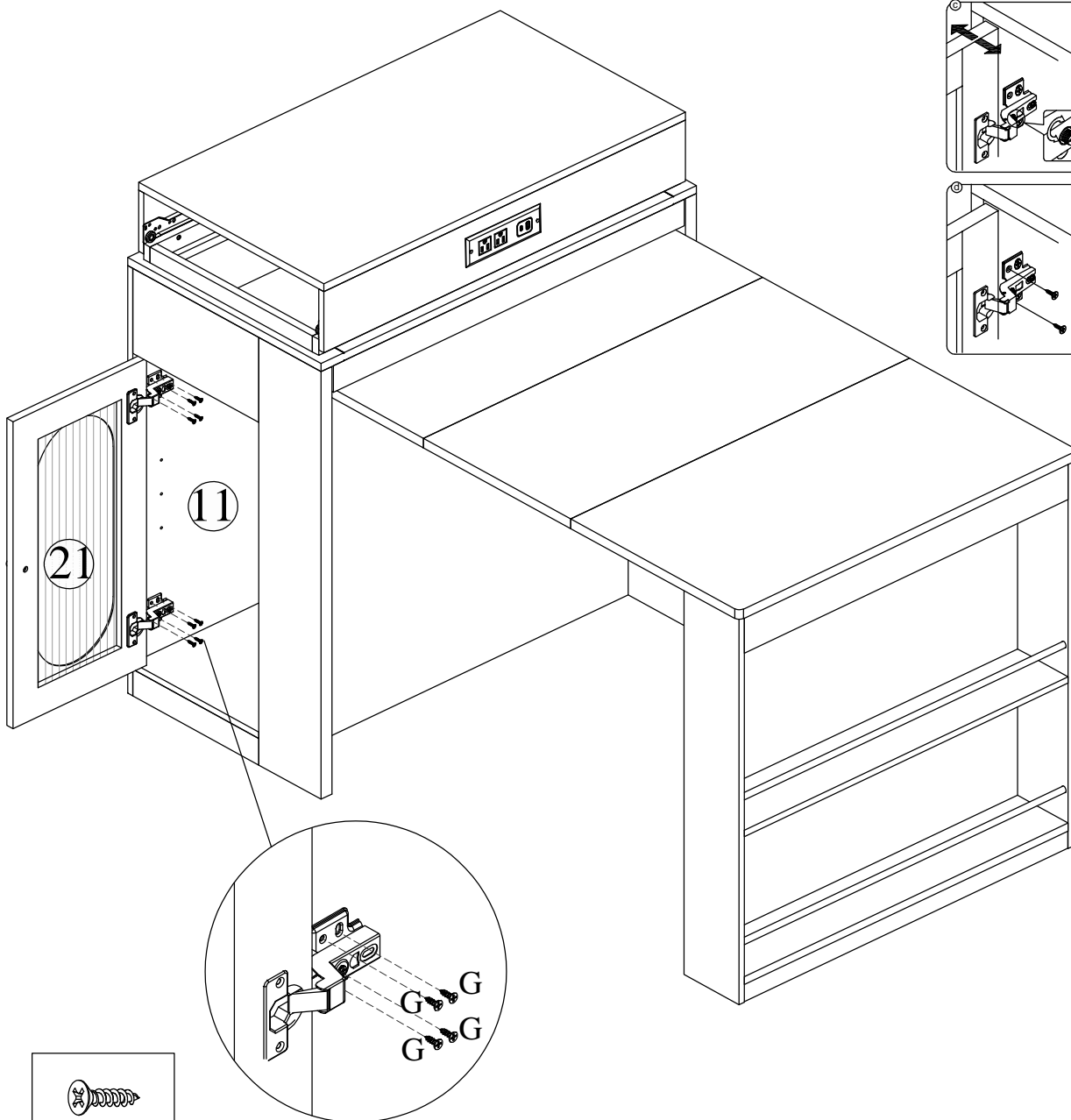

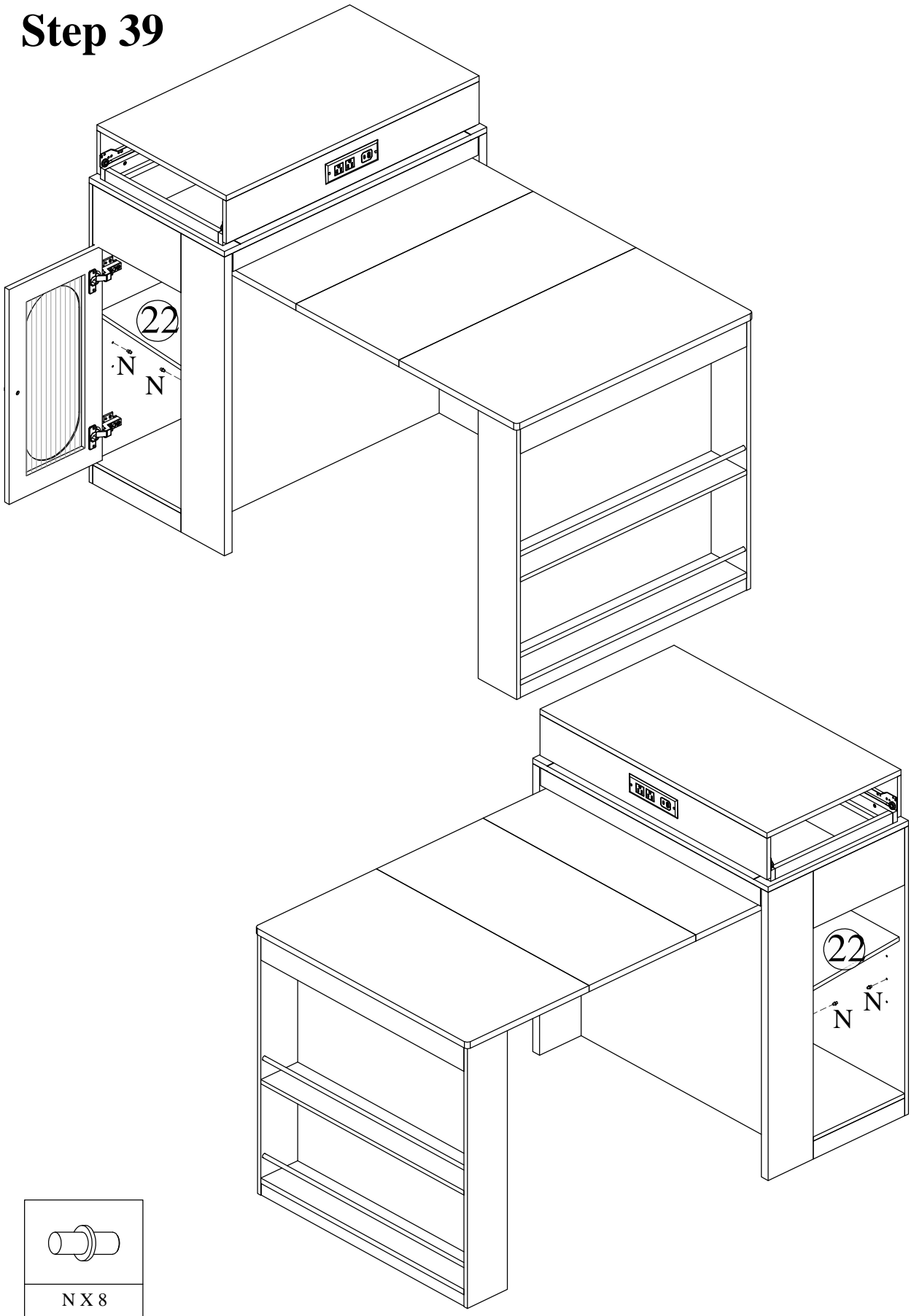

04*12mm
G X 8

Step 39

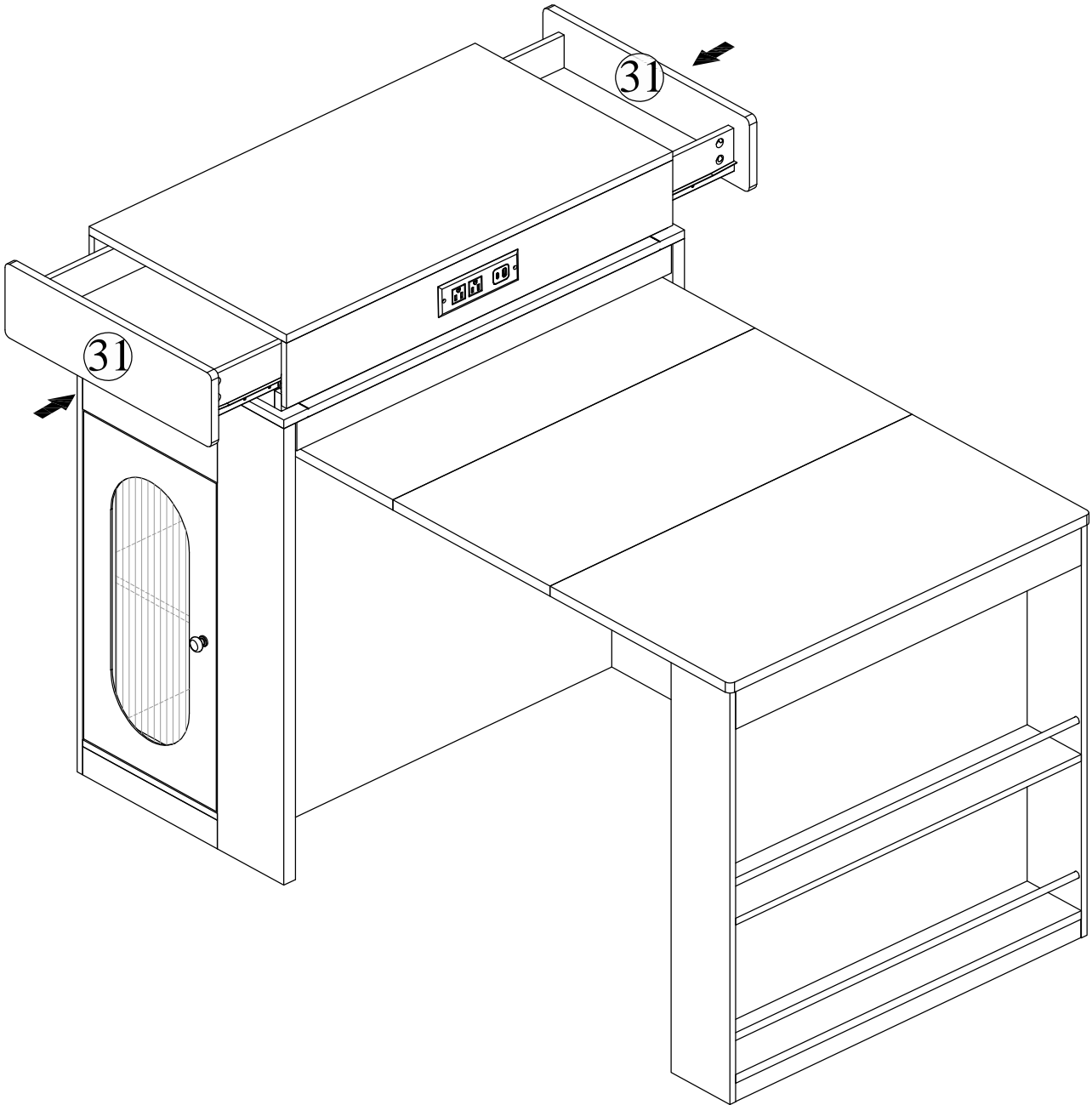

Step 40



Step 41

Lift up the front bar (Panel 14) before closing the table

(a)

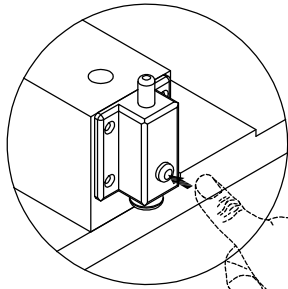

Unlock

(b)

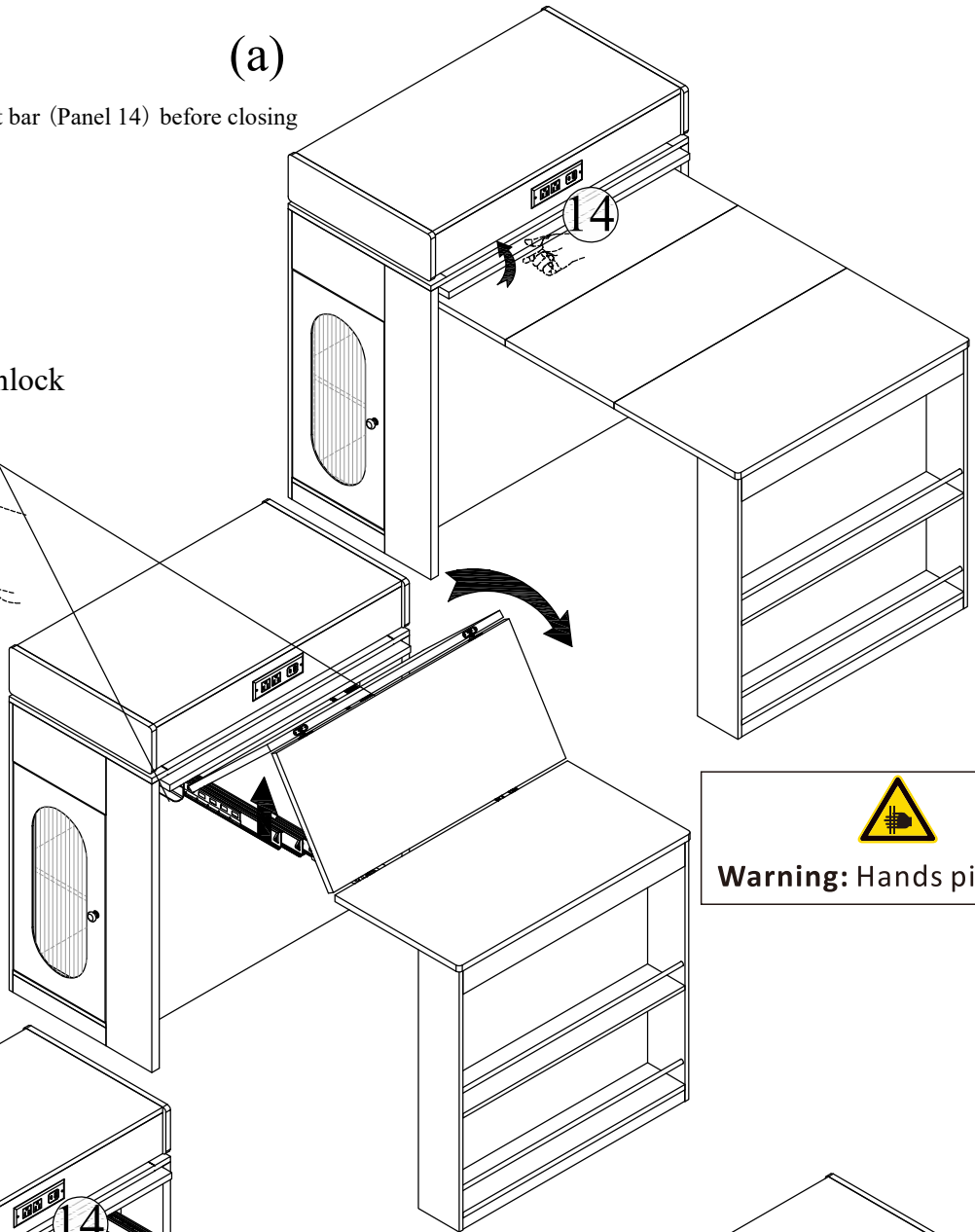

Warning: Hands pinching.

(c)

(d)

Lift up the front bar (Panel 14) before closing the table