

# Assembly Instructions

**3100201 Side Table - Cinnamon**

**3100207 Side Table - Espresso**

Product Issues? Please Call Us Before Contacting Your Retailer At 1-800-549-3300  
Email [customerservice@mshome.co](mailto:customerservice@mshome.co), or visit [www.mshome.co](http://www.mshome.co)  
We can help with Assembly Issues, Part Requests, Damages, & All Other Product  
Related Questions

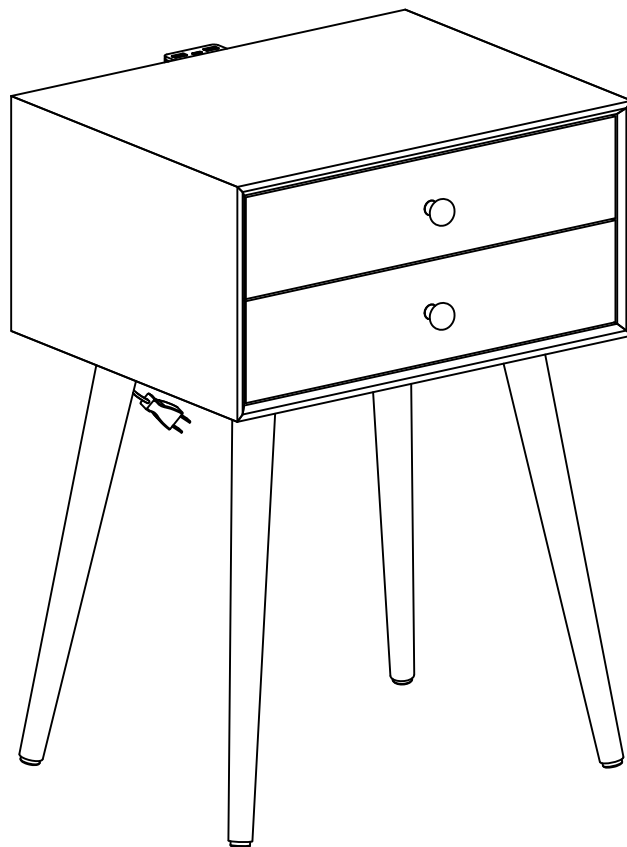

**MSH-USA**

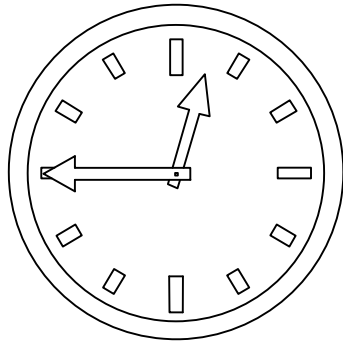

8 min

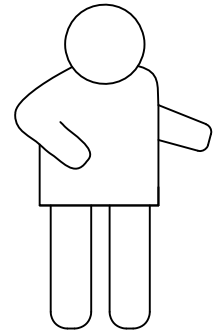

One People Required

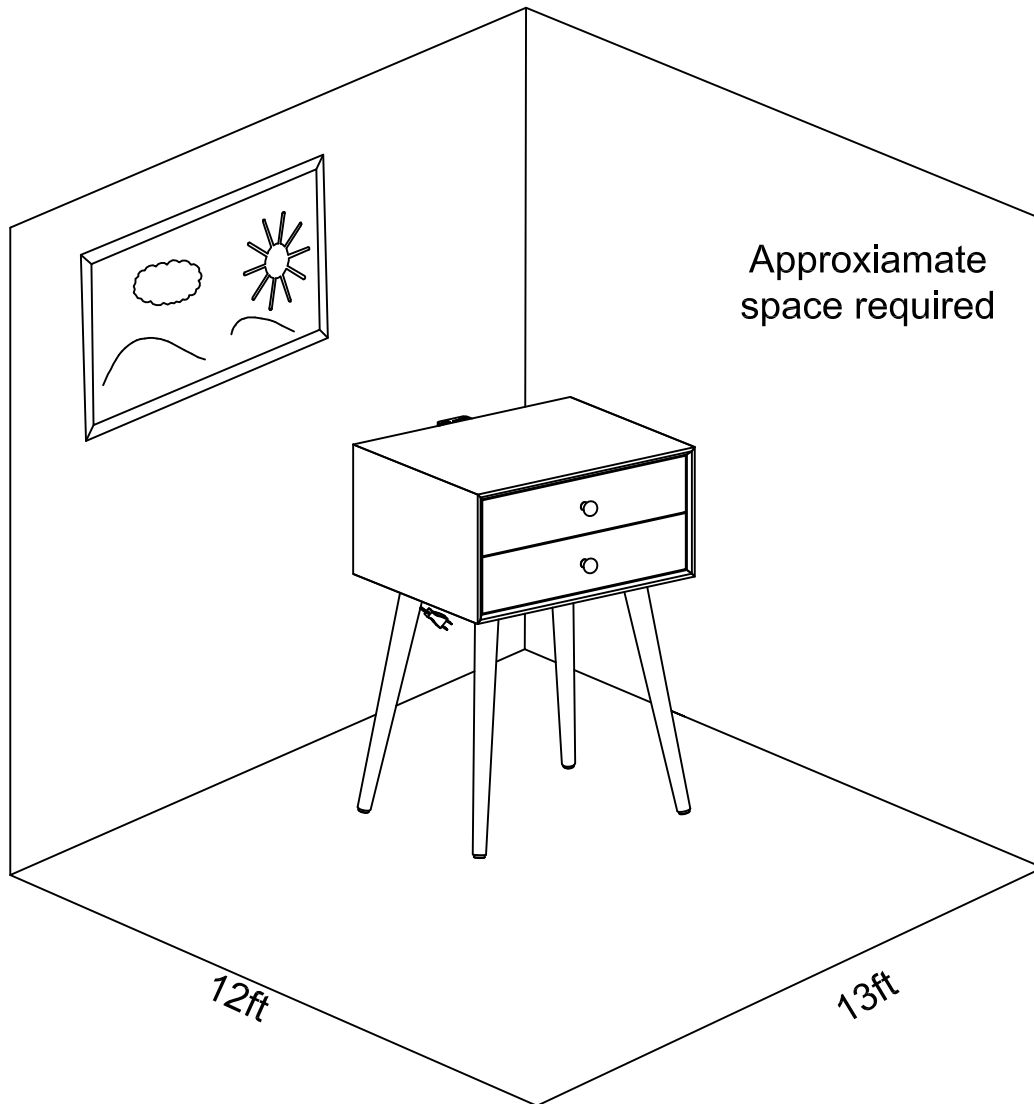

Approximate  
space required

12ft

13ft

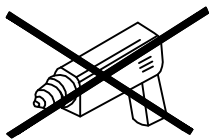

Do not use power tools

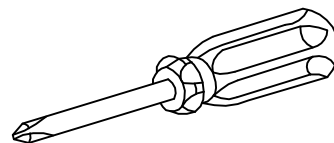

Phillips Head (Not provided)

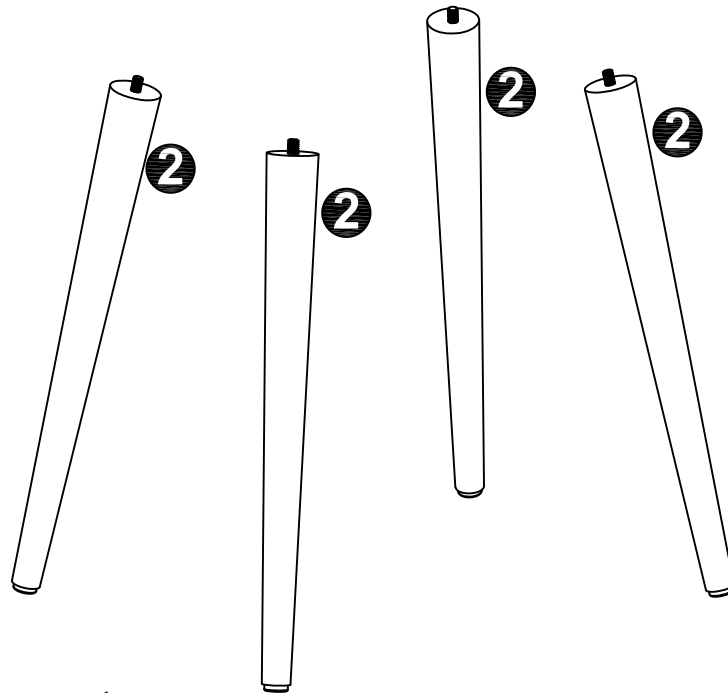
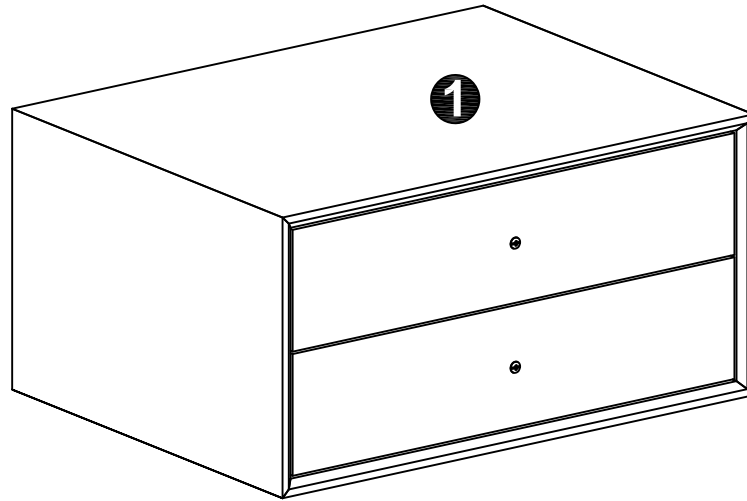

### Replacement parts:

1 - Top Frame x 1

2 - Leg x 4



### Hardware Pack

A x 01

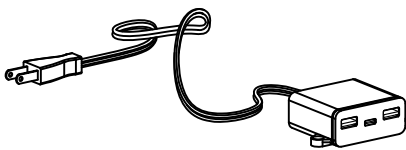

B x 02

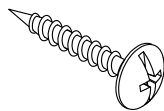

Ø3 x 15 (mm)

C x 02 in bag  
(+2 in drawer)



D x 02 in bag  
(+2 in drawer)

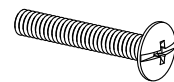

Ø4 x 25 (mm)

1

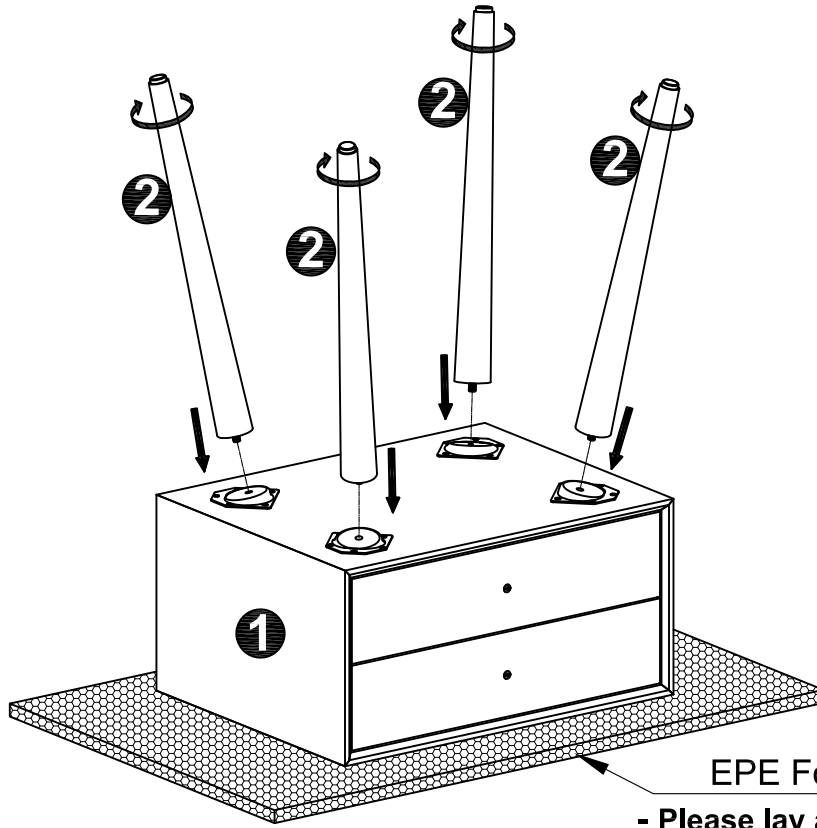

EPE Foam

- Please lay all components on smooth flat surface to prevent scratches.

2

A x 1



B x 2

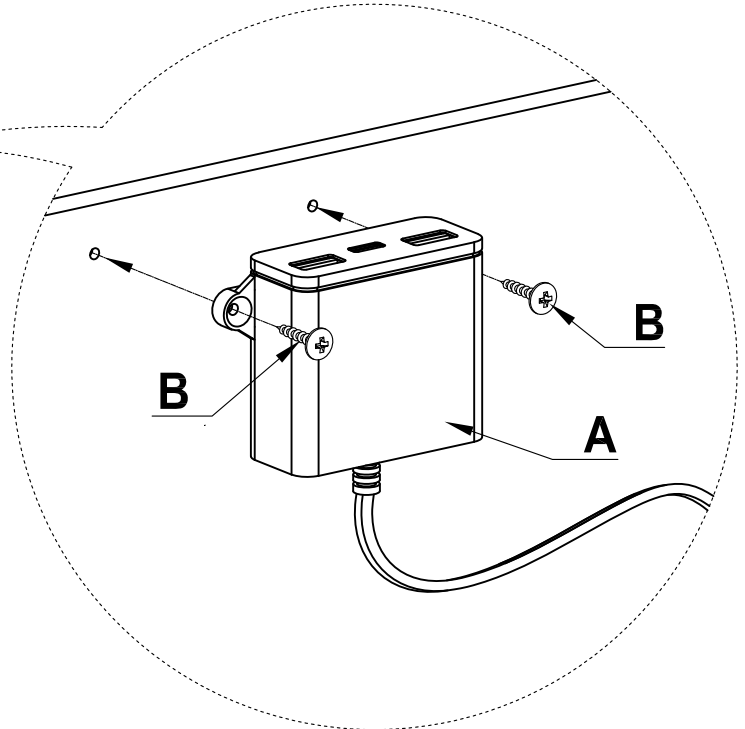
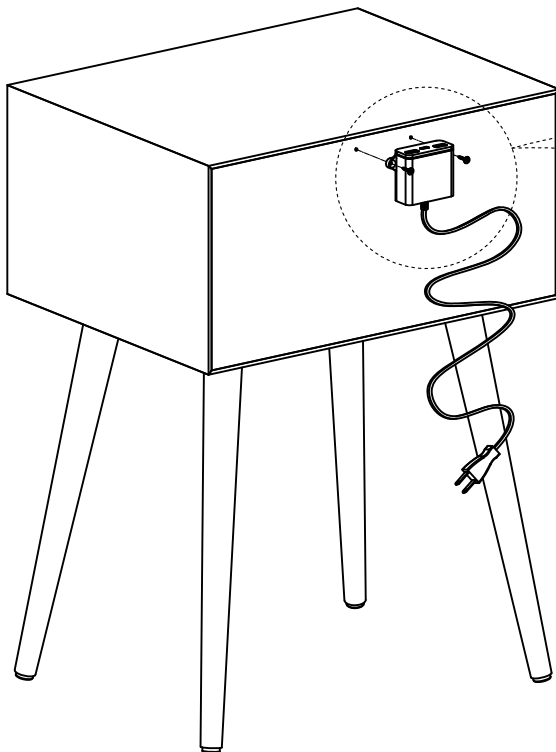
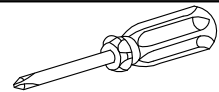
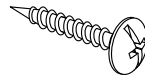

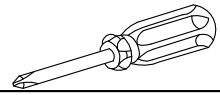
**3**

Pull the drawers out, then turn the bolts counterclockwise to remove the handles from the drawers as shown below.

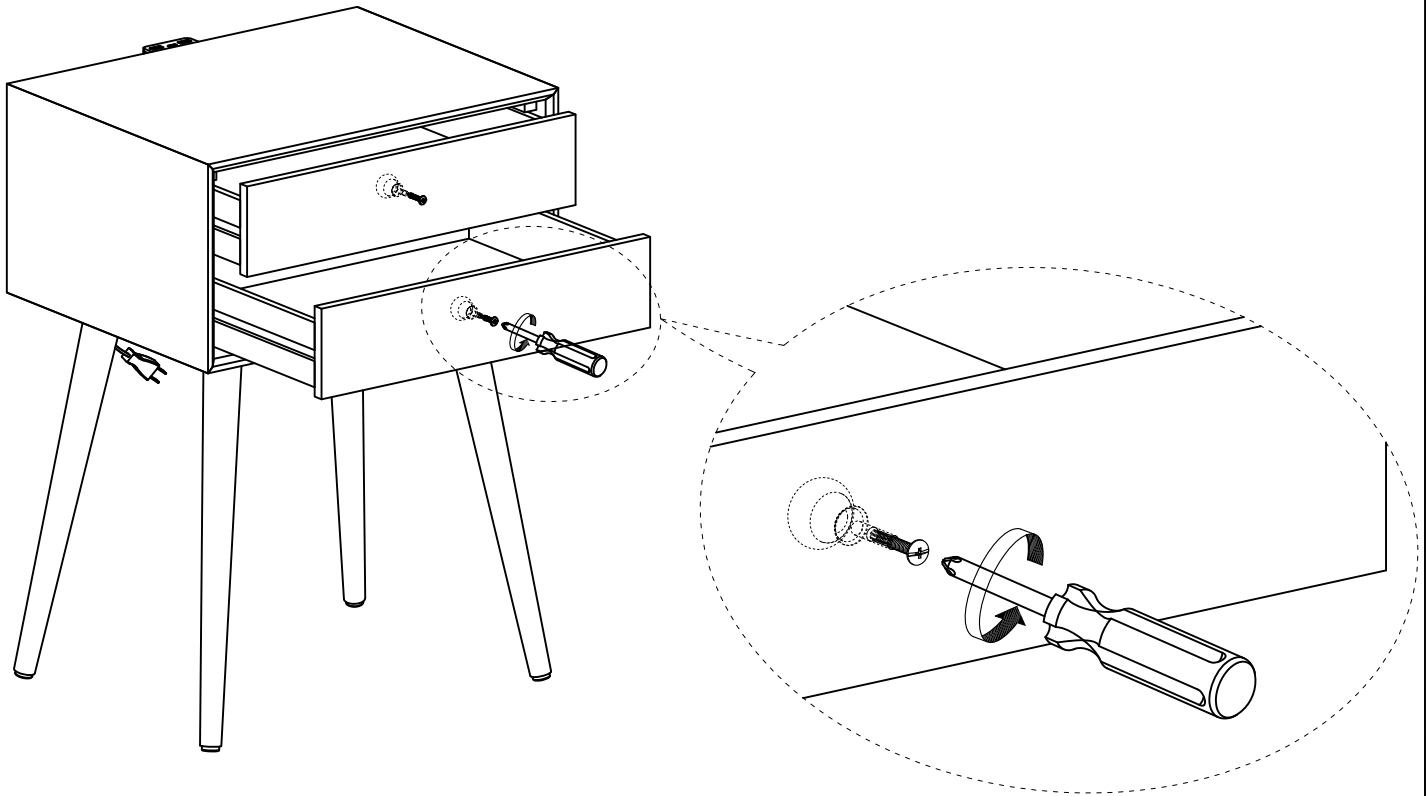
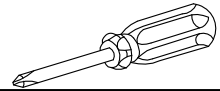
**4****C x 2****D x 2**

Turn the bolts clockwise to tighten the handles as shown below. You can use the handle attached to the drawer, or replace it with another handle in the bag, depending on your preference.

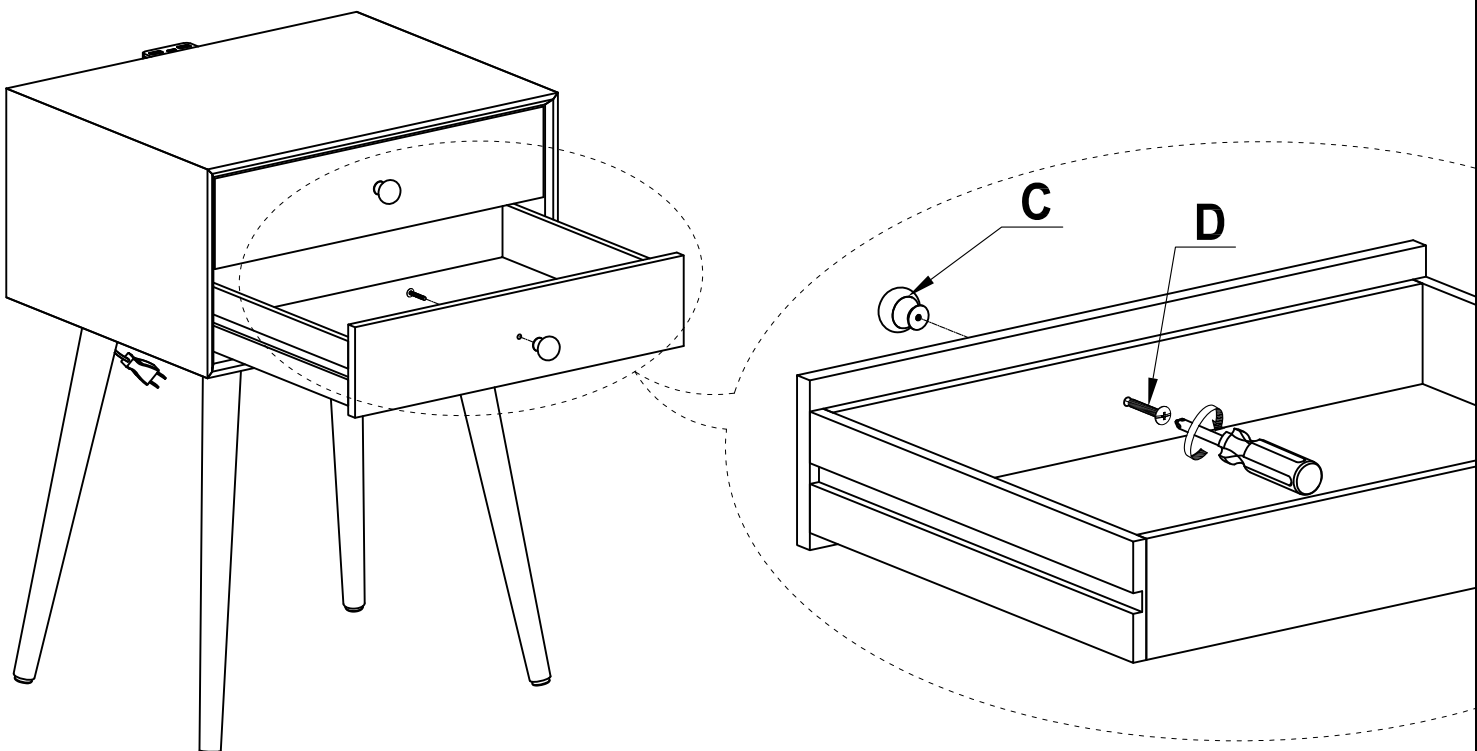



## Replacement Part Form

Have an issue? Need a replacement part?

Please E-mail us before contacting your retailer, we will be happy to fix your issue.

This process will be hassle free! We will replace your part for free!

Please follow these easy steps below.

You will need to E-mail *Martin Svensson Home* Customer Service: [Customerservice@mshome.co](mailto:Customerservice@mshome.co)  
(Please note it is .CO not .com)

Please scan or take a picture of this form filled out.

1. **Customer Name:** \_\_\_\_\_

2. **SKU# with issue:** \_\_\_\_\_

3. **Replacement Part # needed** \_\_\_\_\_

\*Please reference the Assembly Instructions to identify needed part #'s

4. **Photos of the Damaged Part** (please include in the e-mail)

5. **Brief description of the part issue:** \_\_\_\_\_

6. **Proof of Purchase** (please provide a copy of your purchase receipt)

7. **Ship to Address:** \_\_\_\_\_

\_\_\_\_\_

\_\_\_\_\_

8. **Other contact information:**

**Email Address** \_\_\_\_\_

**Phone #** \_\_\_\_\_

\*If possible, could you please provide the UPS or FedEx tracking from original shipment \_\_\_\_\_

\*If possible, could you please provide the P.O. # - information found on back/underneath product \_\_\_\_\_

\*If you have any other question, we are happy to assist with assembly questions or all other parts related questions. Thank you for your purchase!