

Installation & Assembly

Version: 1.0

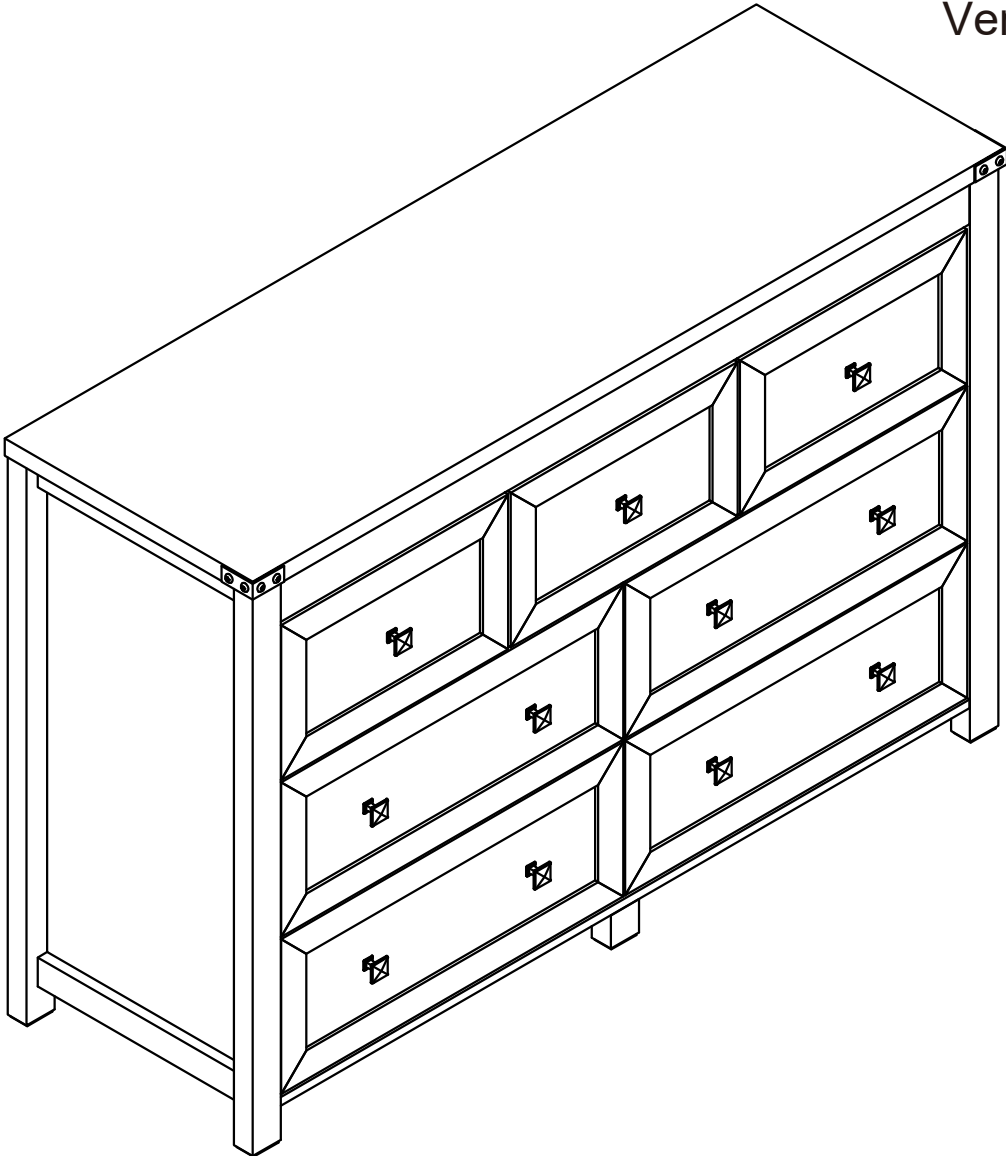

EN_IMPORTANT, RETAIN FOR FUTURE REFERENCE: READ CAREFULLY.

USING CAM LOCK AND QUICKFIT

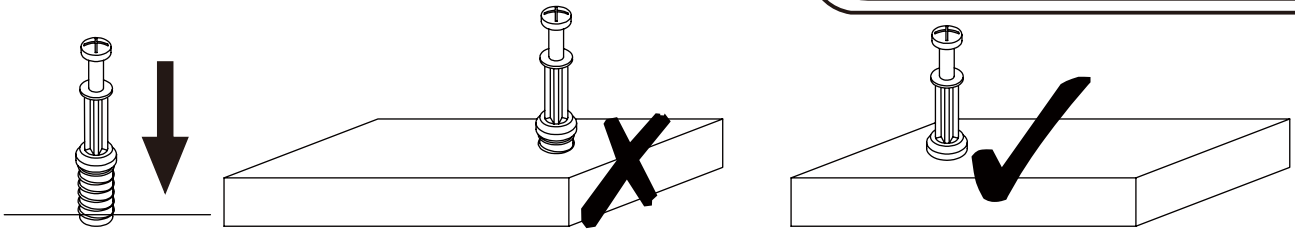

EN_QUICKFIT: Tighten quickfit until shoulder is flush with panel. Do not overtighten or undertighten.

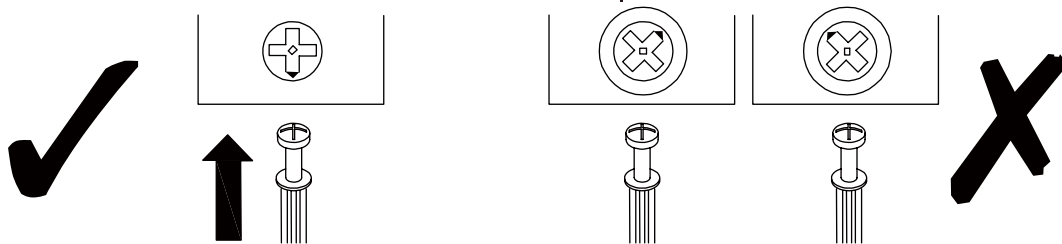

EN_CAM LOCK: When fitting cam lock, ensure starting position is correct before you insert connecting quickfit.

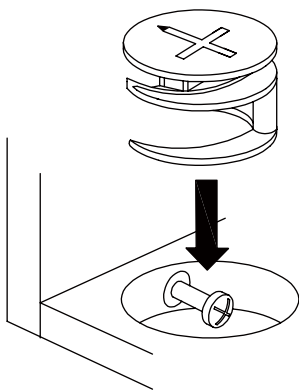

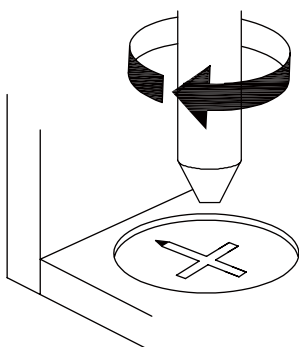

EN_Quickfit head should be in the centre of the cam lock when the two panels are joined.
Cam lock should be inserted before quickfit.



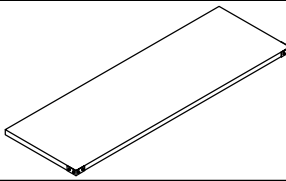
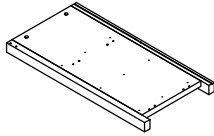
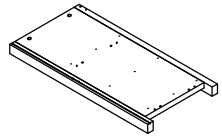
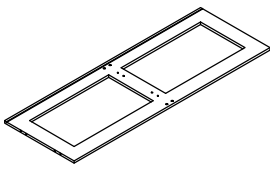

EN_Turn cam lock clockwise to tighten.

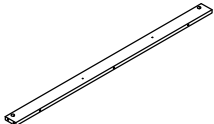
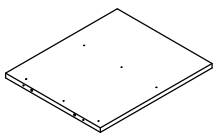
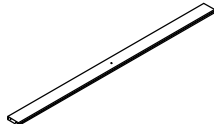
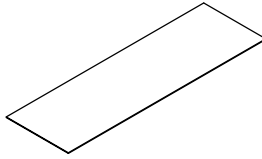
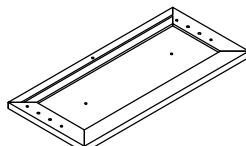
PACKING DETAILS

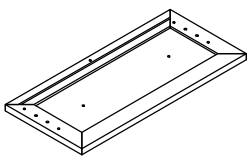
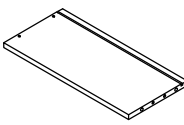
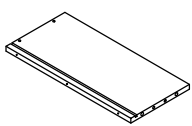
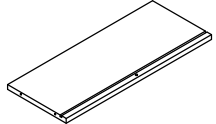
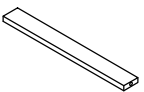
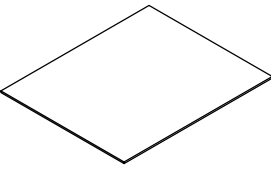
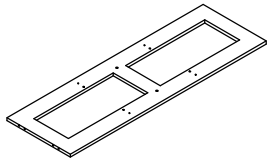
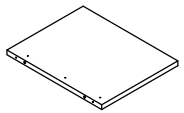
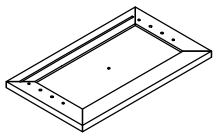
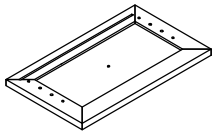



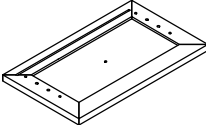
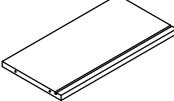
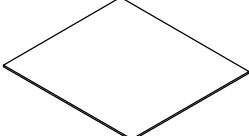



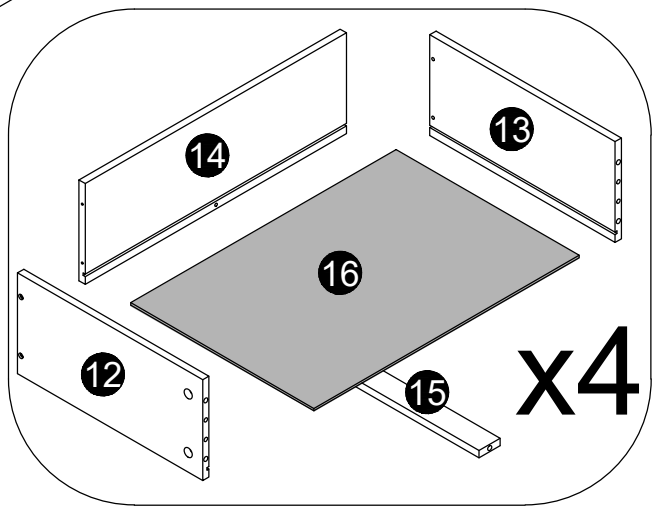
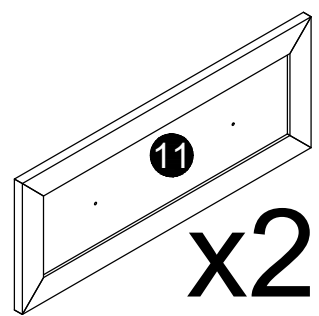
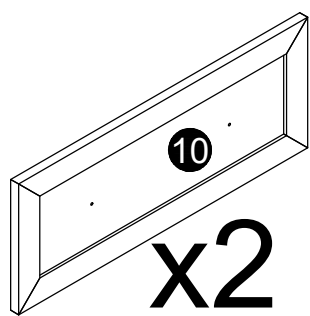
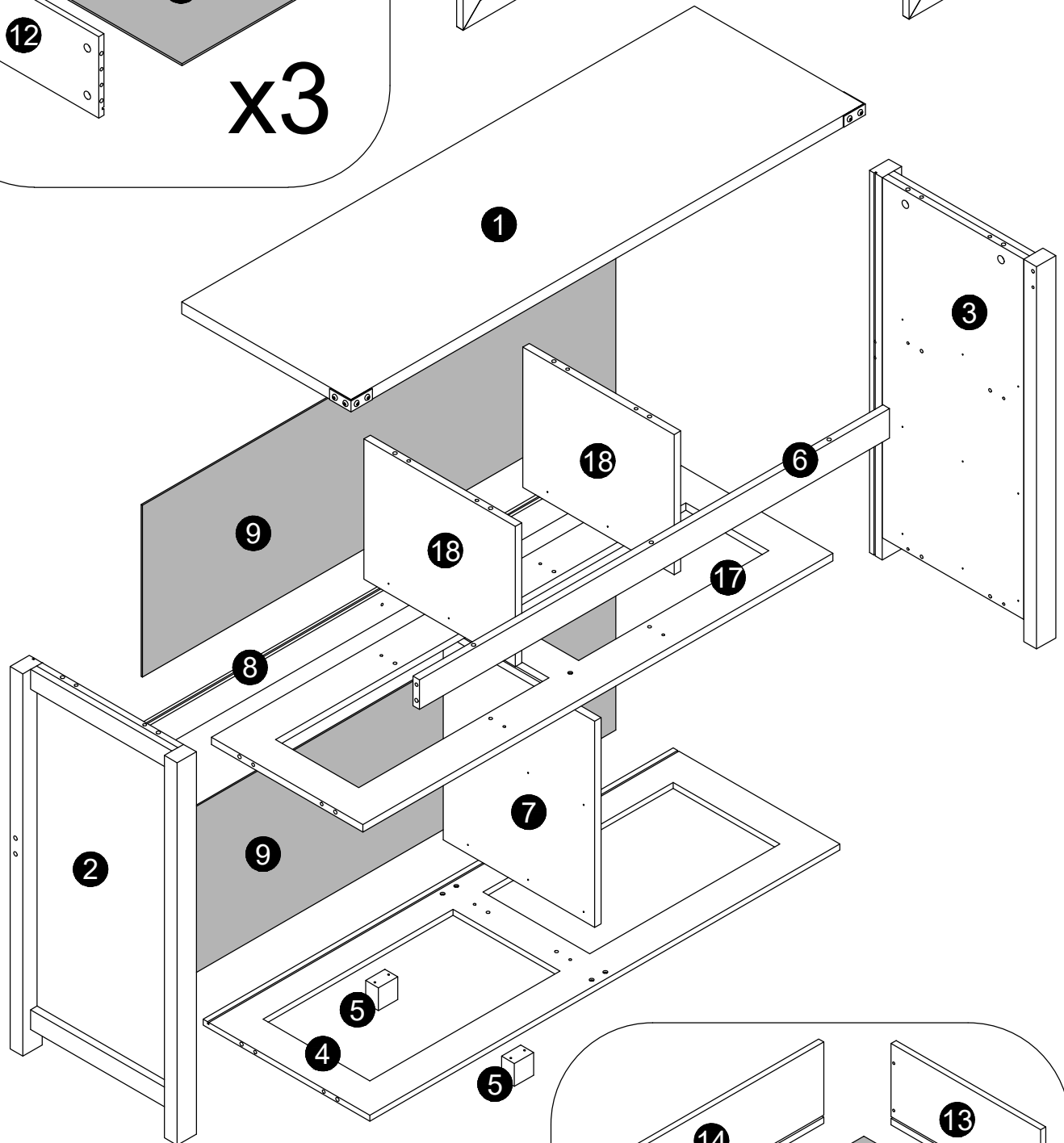
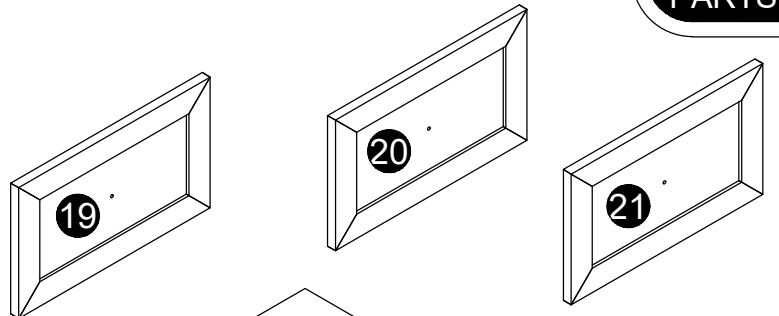
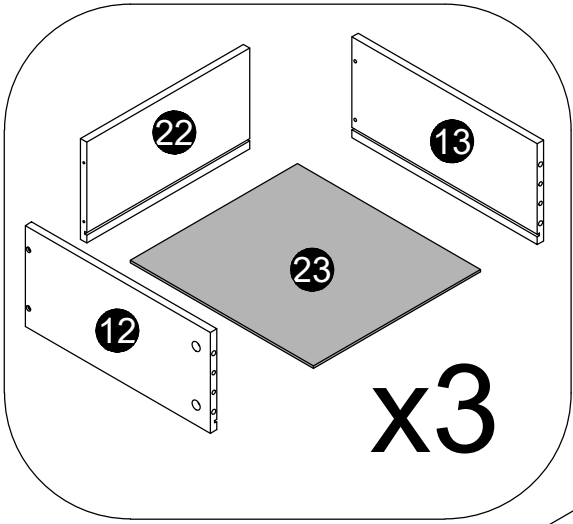

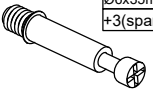

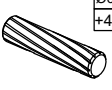
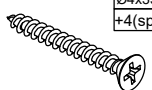

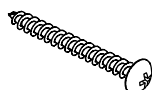

NO.	PARTS	QTY	SPARE
①		x1	
②		x1	
③		x1	
④		x1	
⑤		x2	
⑥		x1	
⑦		x2	
⑧		x1	
⑨		x2	
⑩		x2	

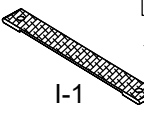

NO.		QTY	SPARE
⑪		x2	
⑫		x7	
⑬		x7	
⑭		x4	
⑮		x4	
⑯		x4	
⑰		x1	
⑱		x2	
⑲		x1	
⑳		x1	

PACKING DETAILS

NO.	PARTS	QTY	SPARE
②1		x1	
②2		x3	
②3		x3	
	 Hardware Kit		

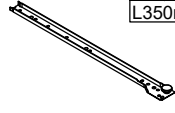
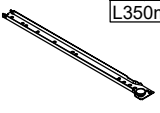
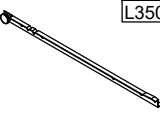
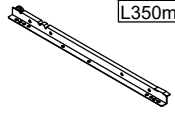

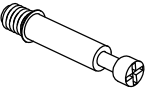
 A x53 Ø6x35mm +3(spare)	 B x53 Ø15x10mm +3(spare)	 C x57 Ø6x30mm +4(spare)	 D x48 Ø4x35mm +4(spare)	 E x88 Ø3.5x12mm +8(spare)	 F x4				
 G x4	 H-1	 H-2	 I-1	 I-2	 J-1	 J-2	 K-1	 K-2	 L x8
 M x2	 CL x7 L350mm	 CR x7 L350mm	 DL x7 L350mm	 DR x7 L350mm					

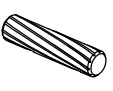
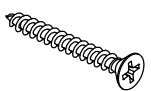
 A x15	 B x15	 C x12	 D x15
---	---	---	---

01

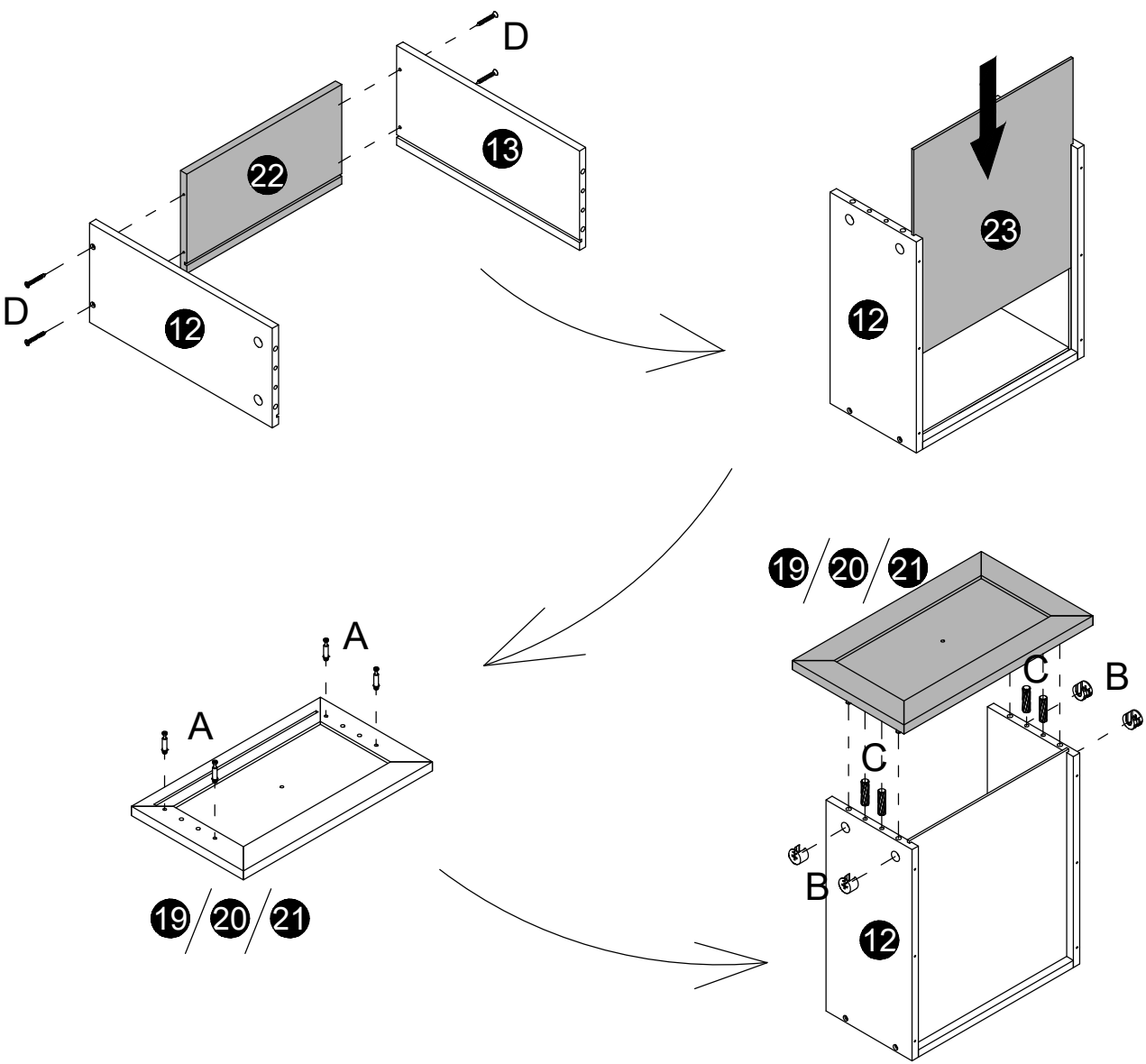

A x20

B x20

C x16

D x20

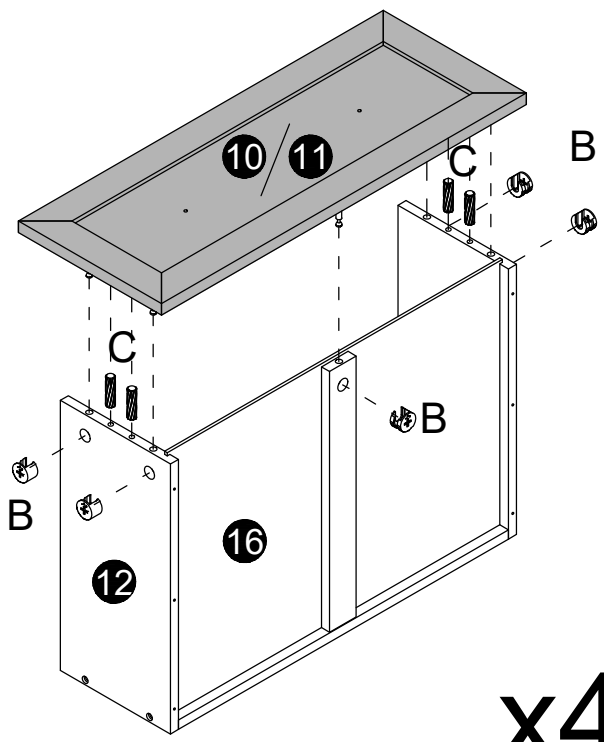
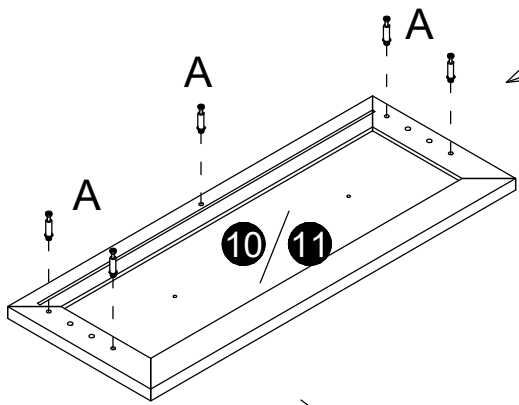
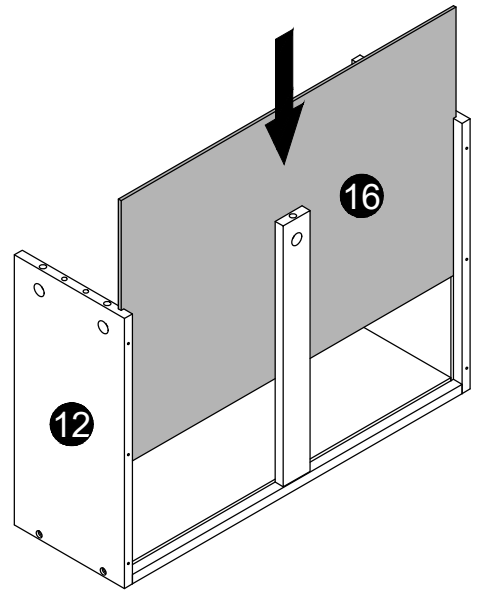
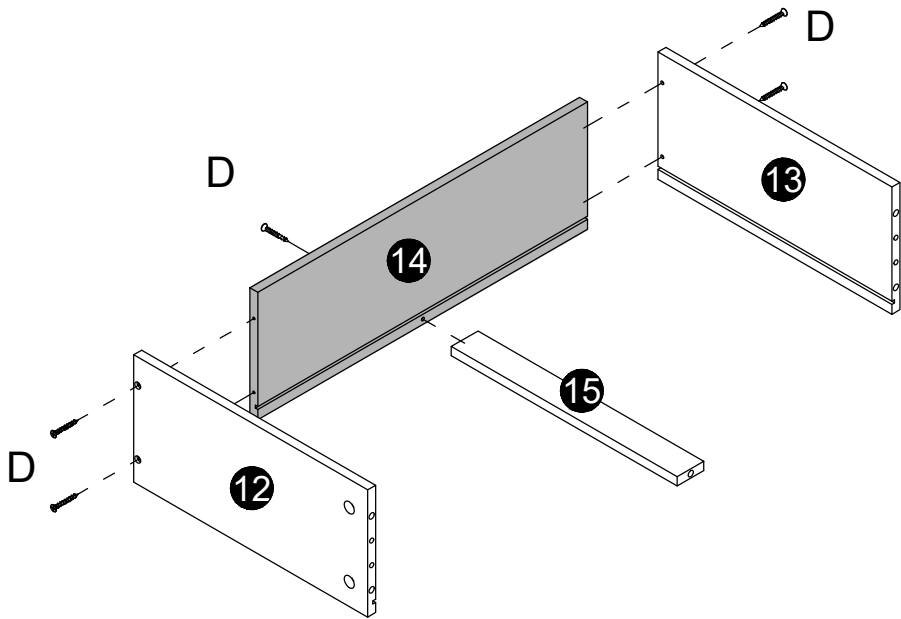
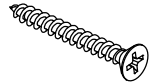
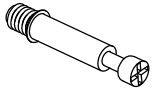

x4

E x42

DL x7

DR x7

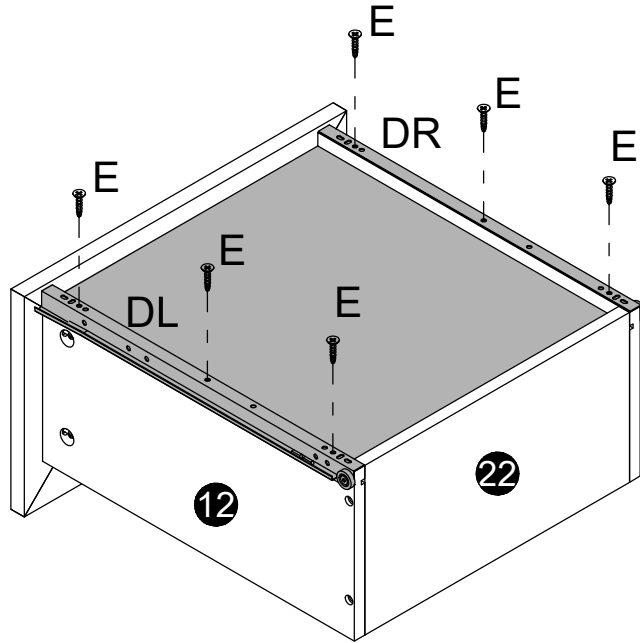
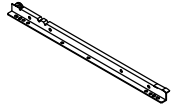
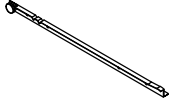

x3

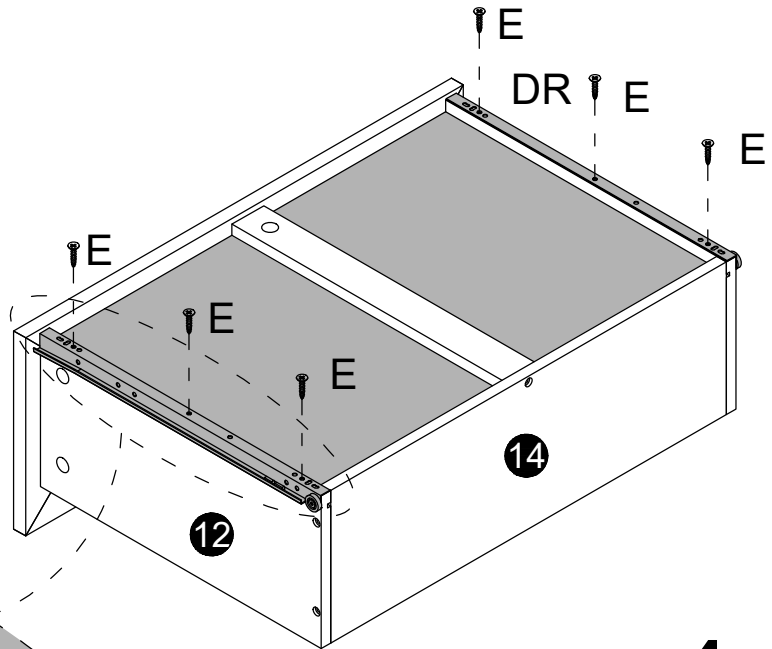

x4

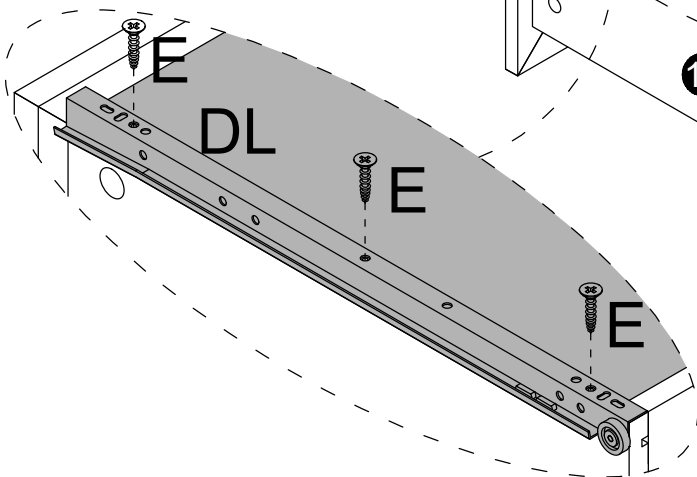

H x11



H-1



H-2

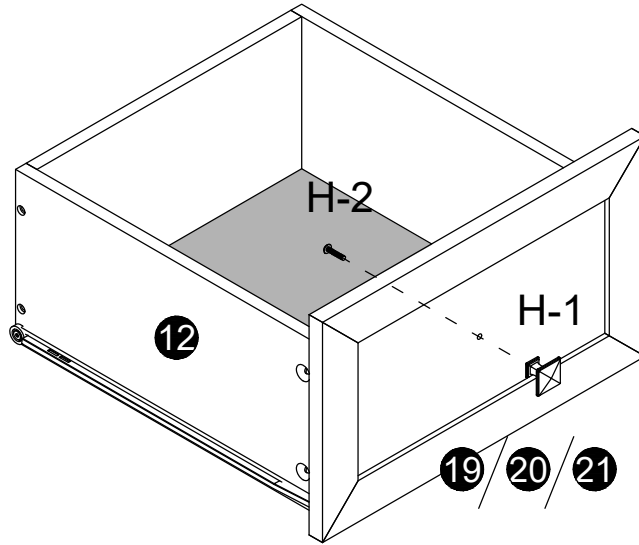

x3

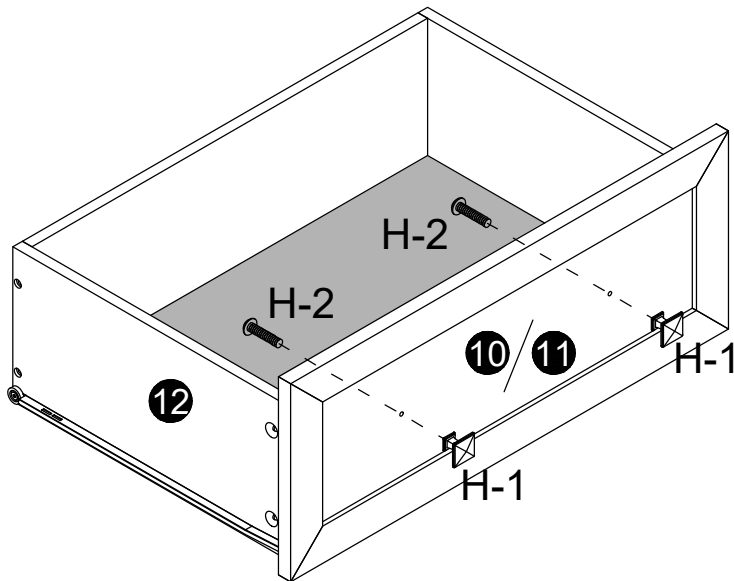

x4

E x42

CL x7

CR x7

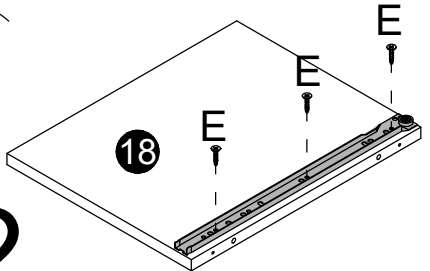
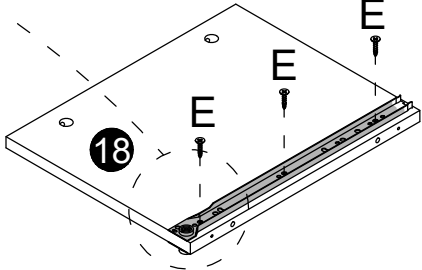
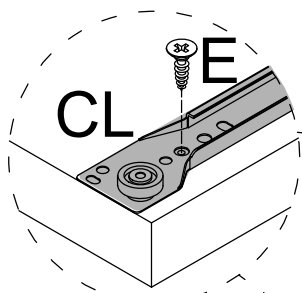
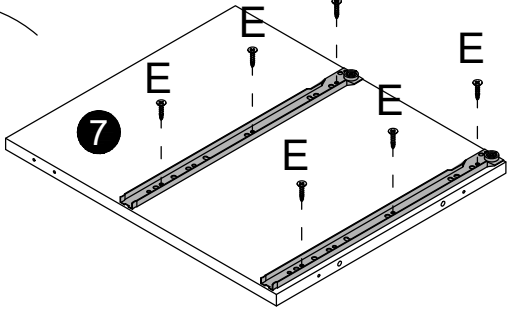
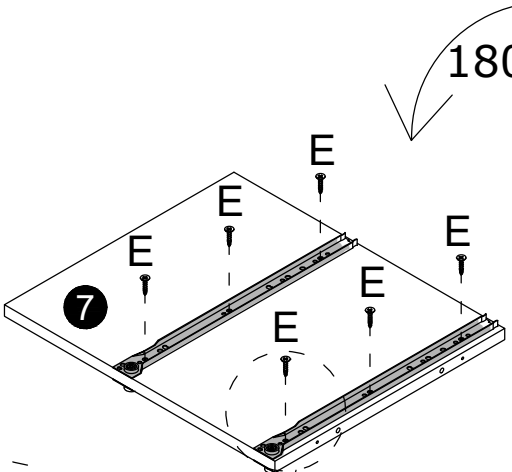
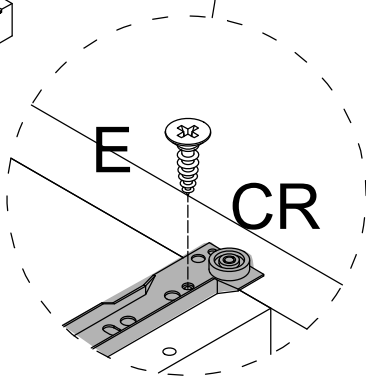
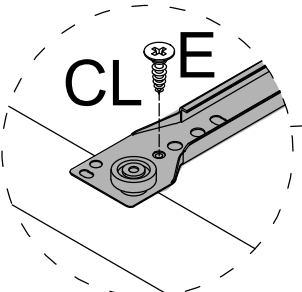
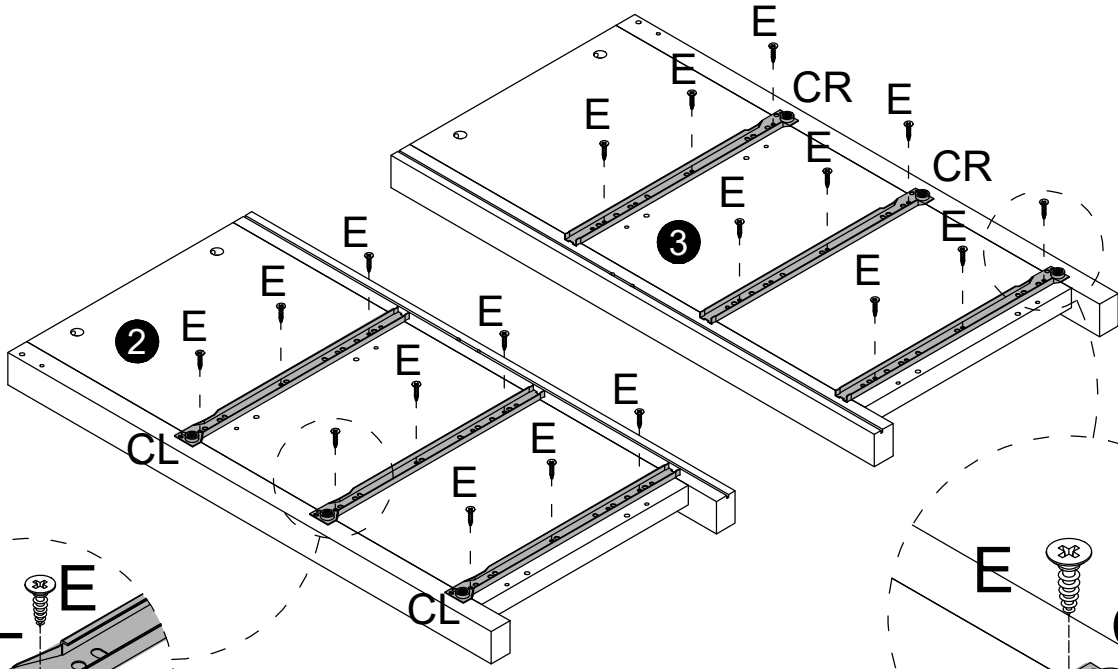
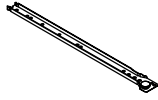
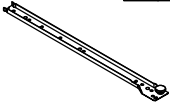

x2

A x10

L x4

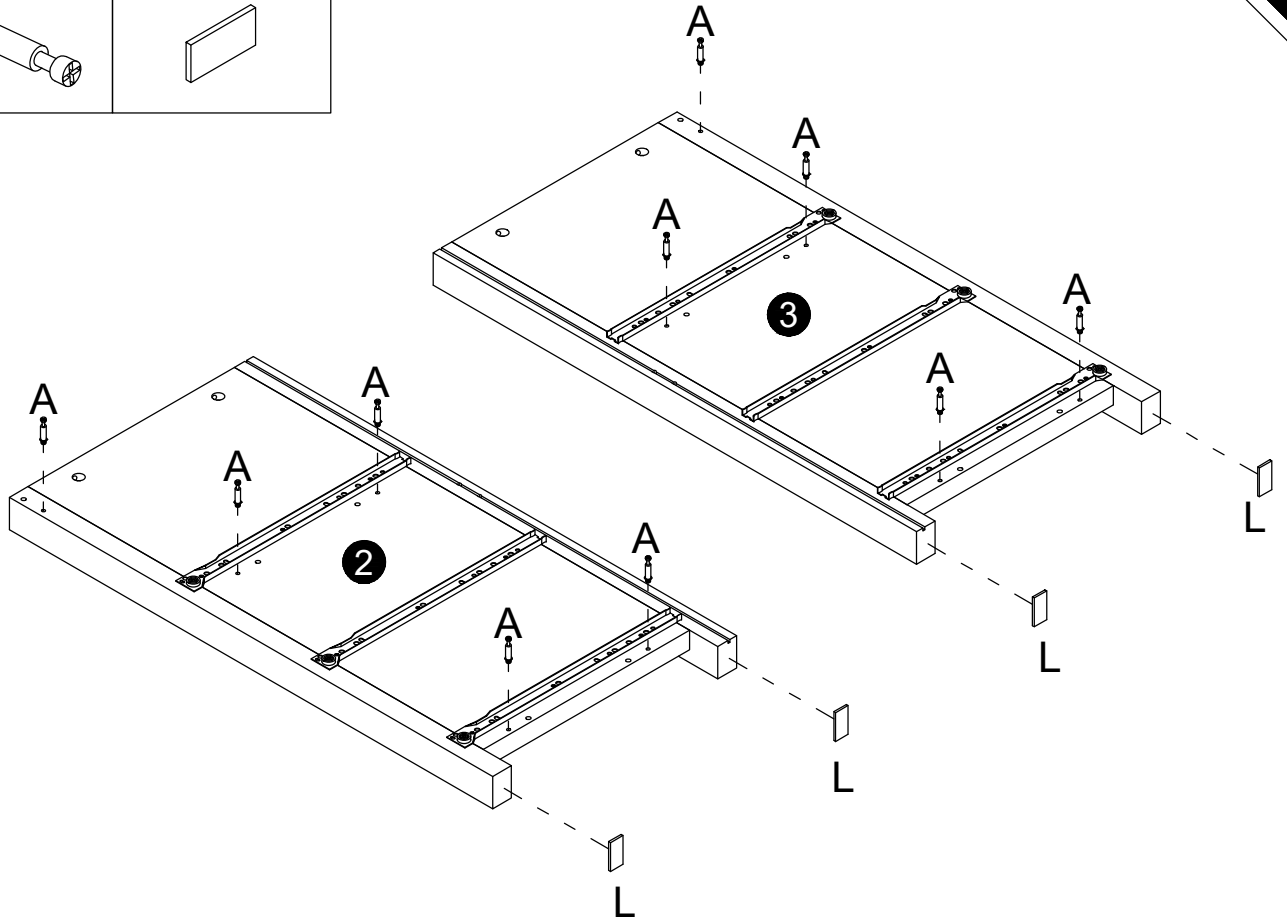
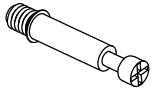

D x4

L x2

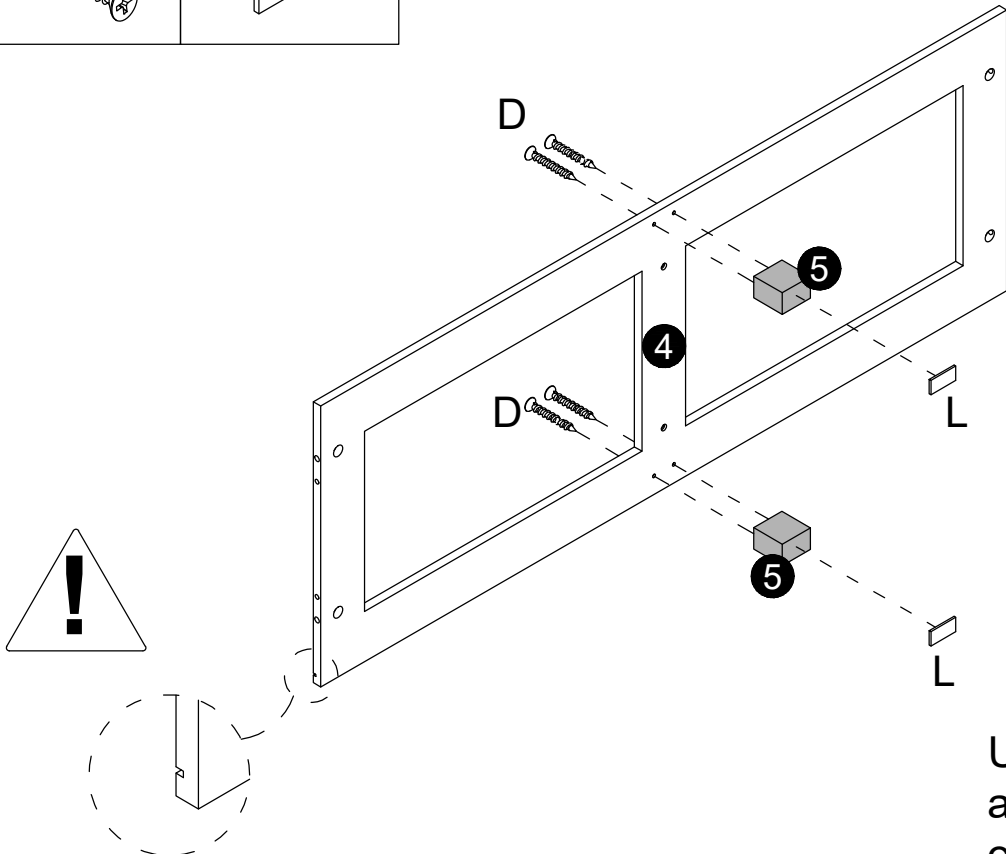
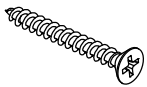

Use floor mats to adjust uneven areas on the ground.

C x8

D x8

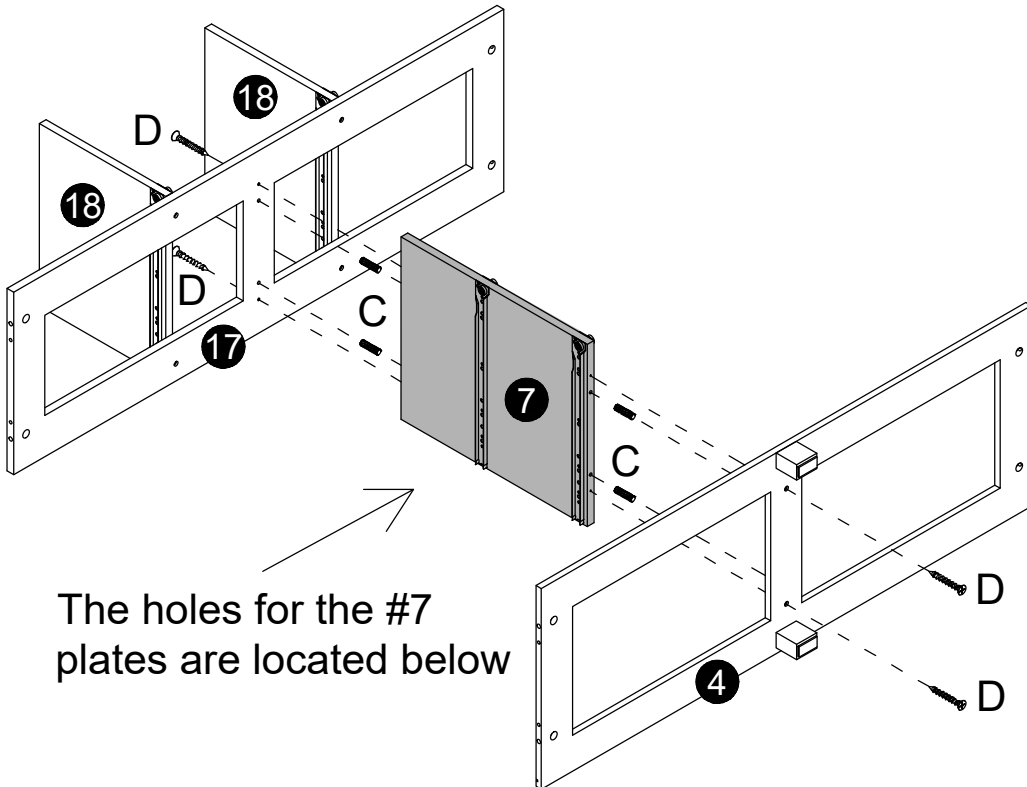
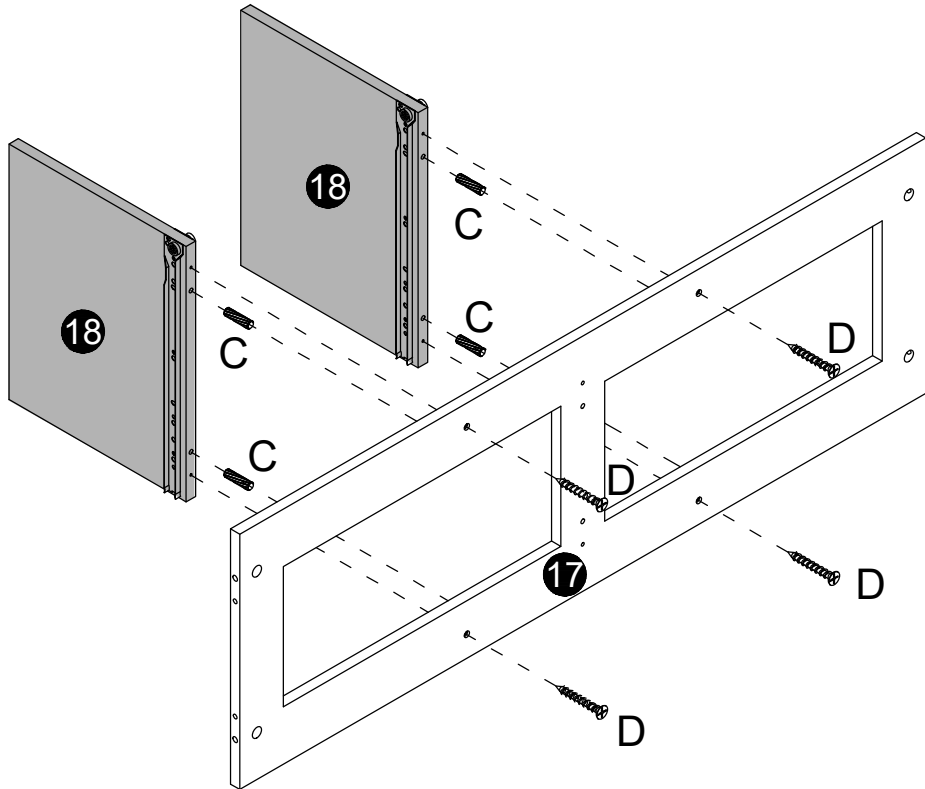
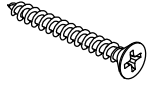

The holes for the #7 plates are located below

B x10

C x10

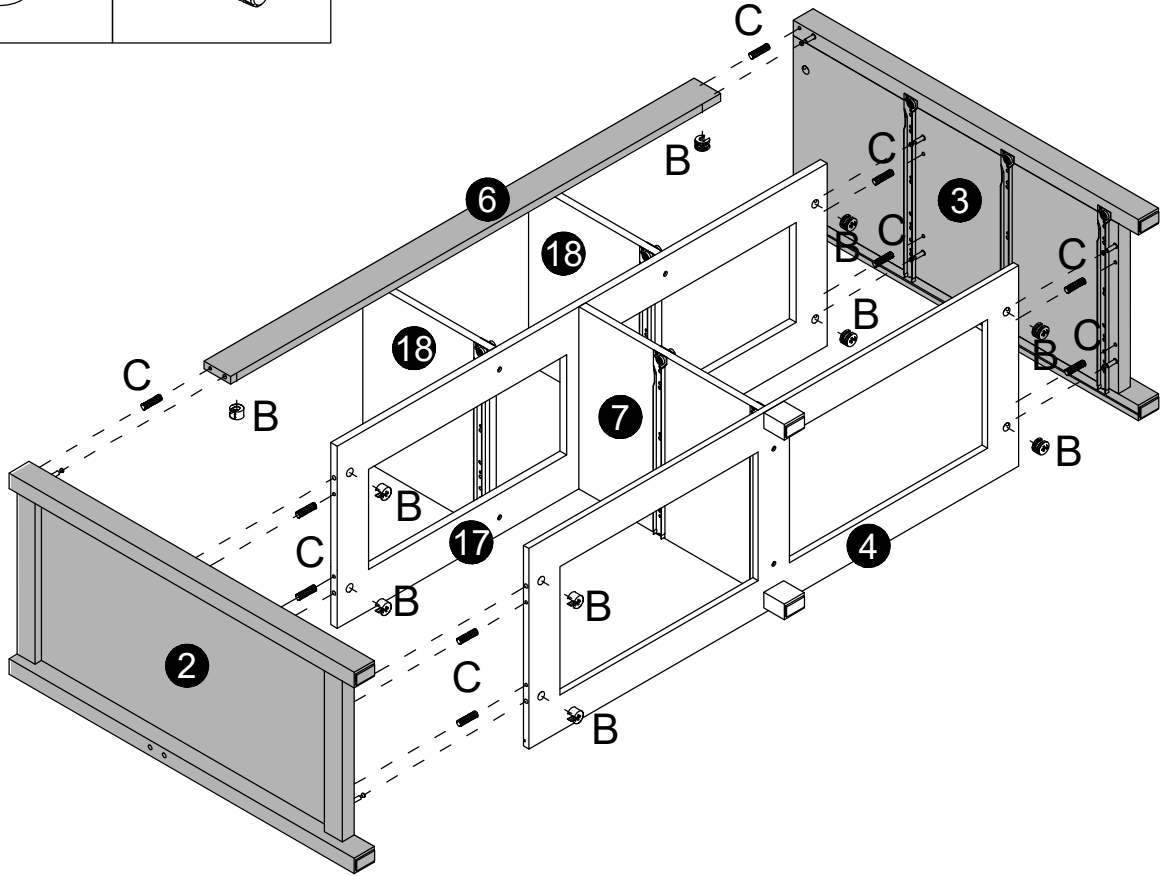
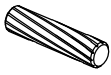

E x4

M x2

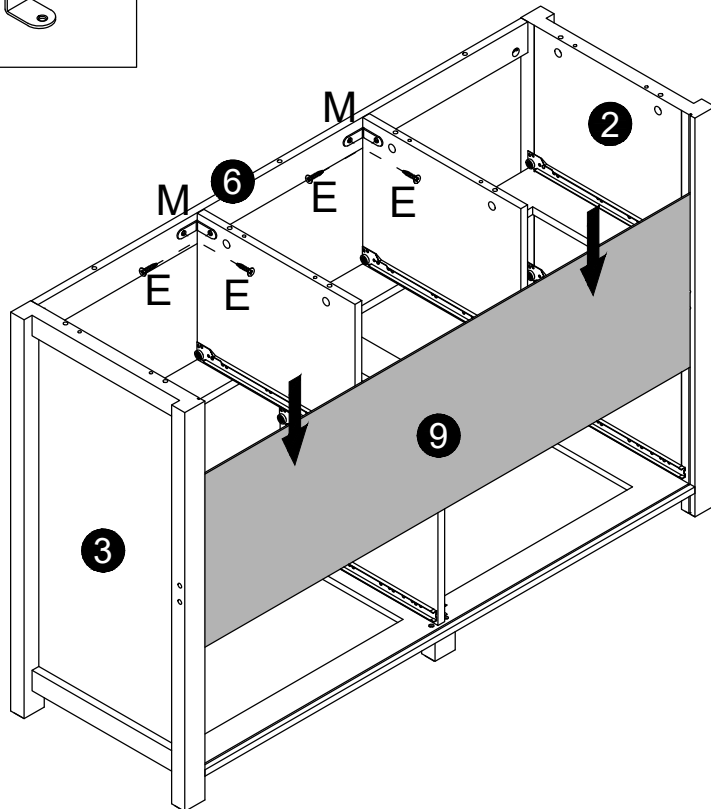

D x1

F x4

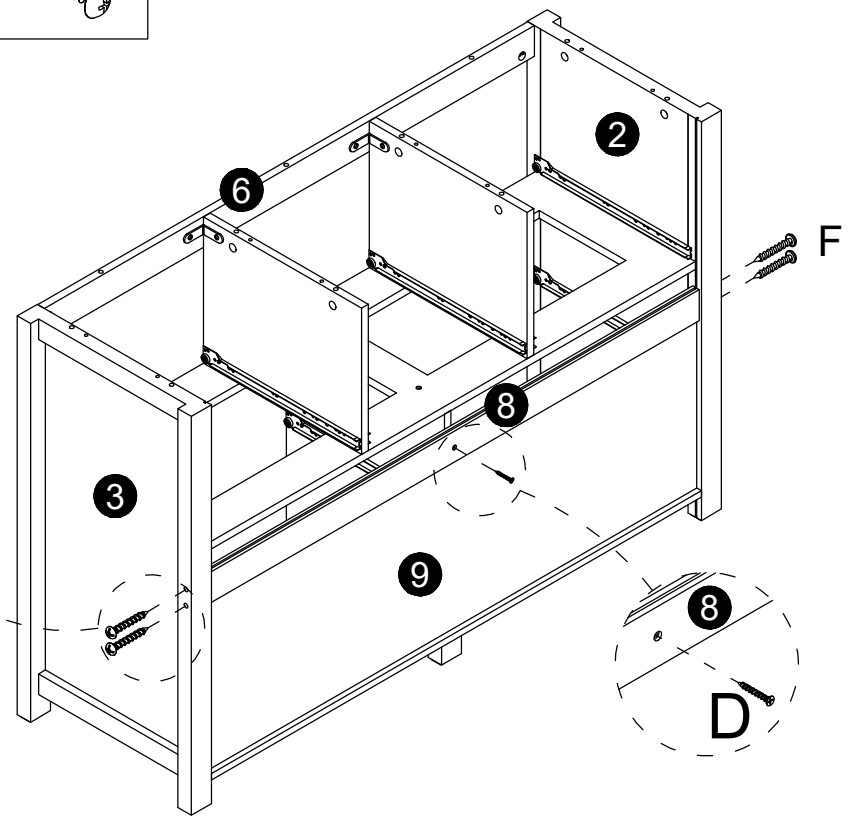
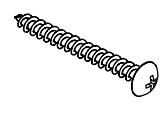
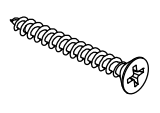

C x11

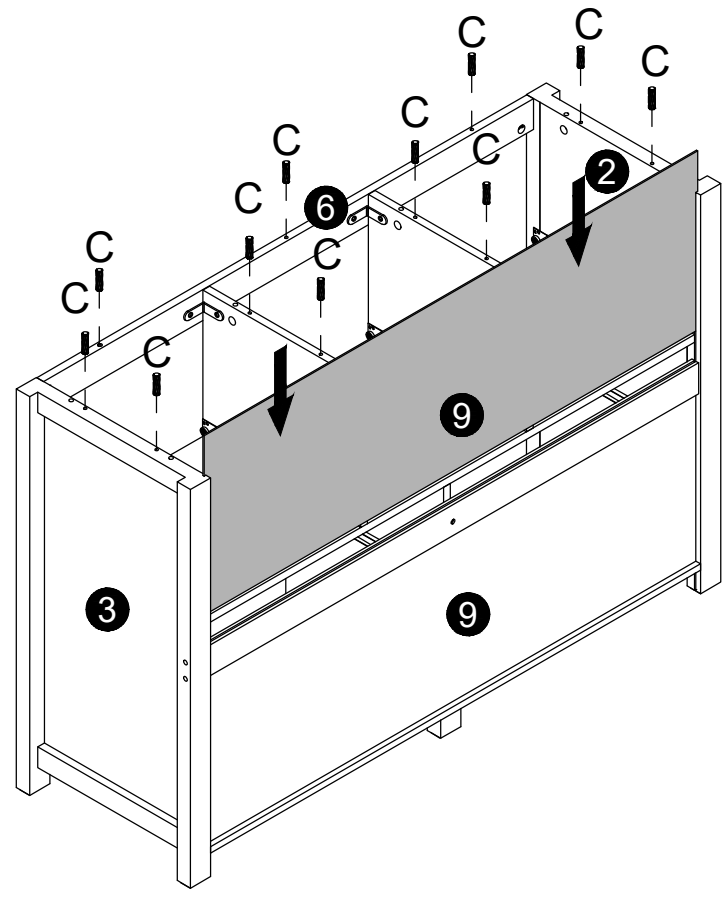
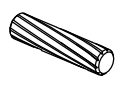

A x8

B x8

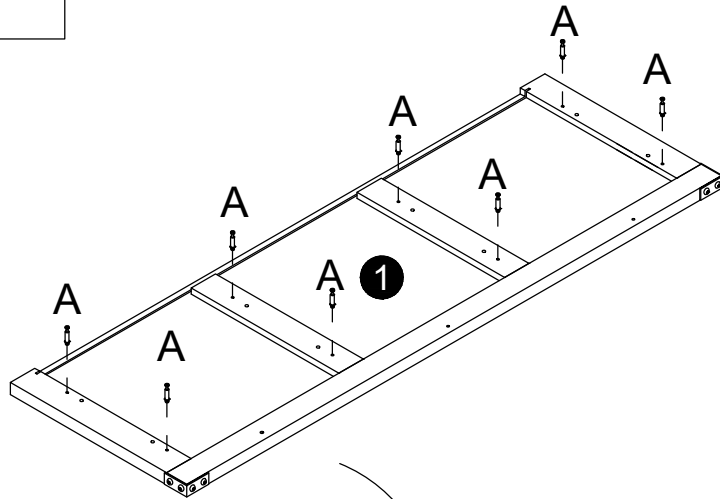
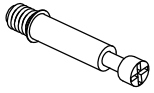

180°

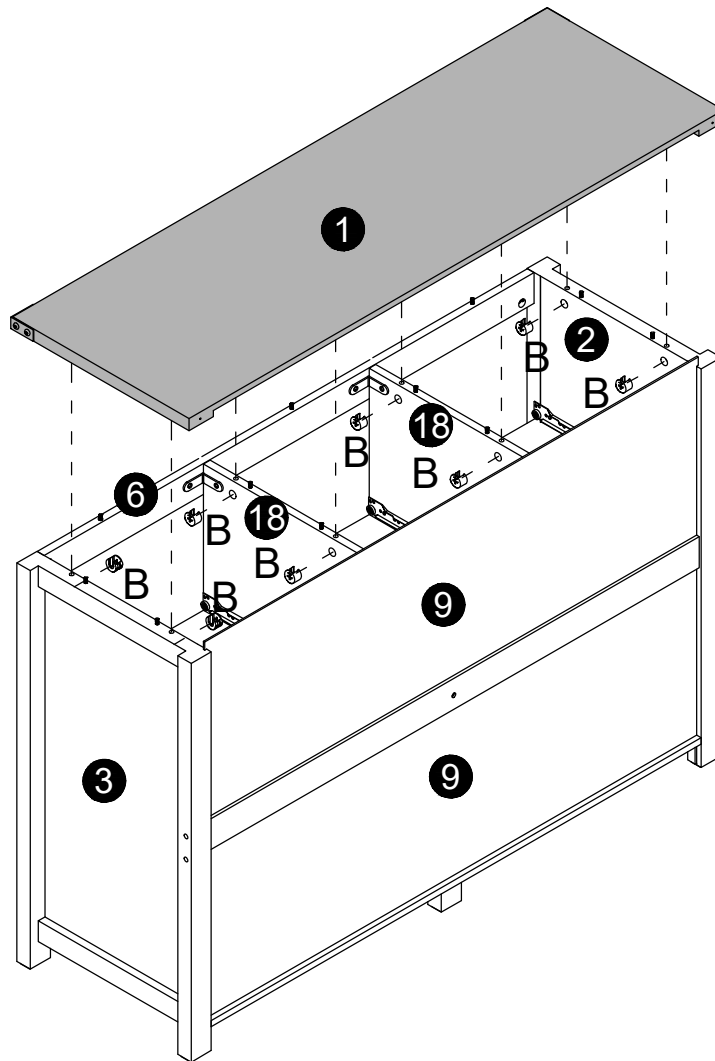

G x4

J x14

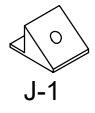

J-1

J-2

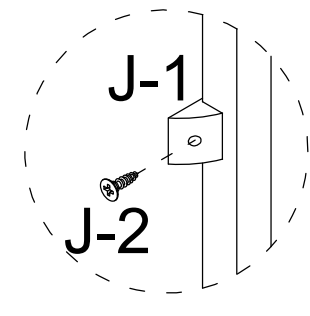
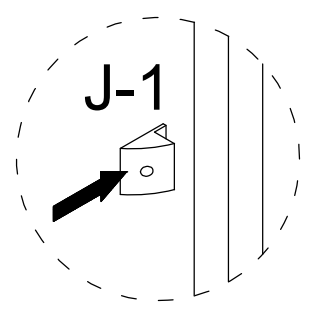
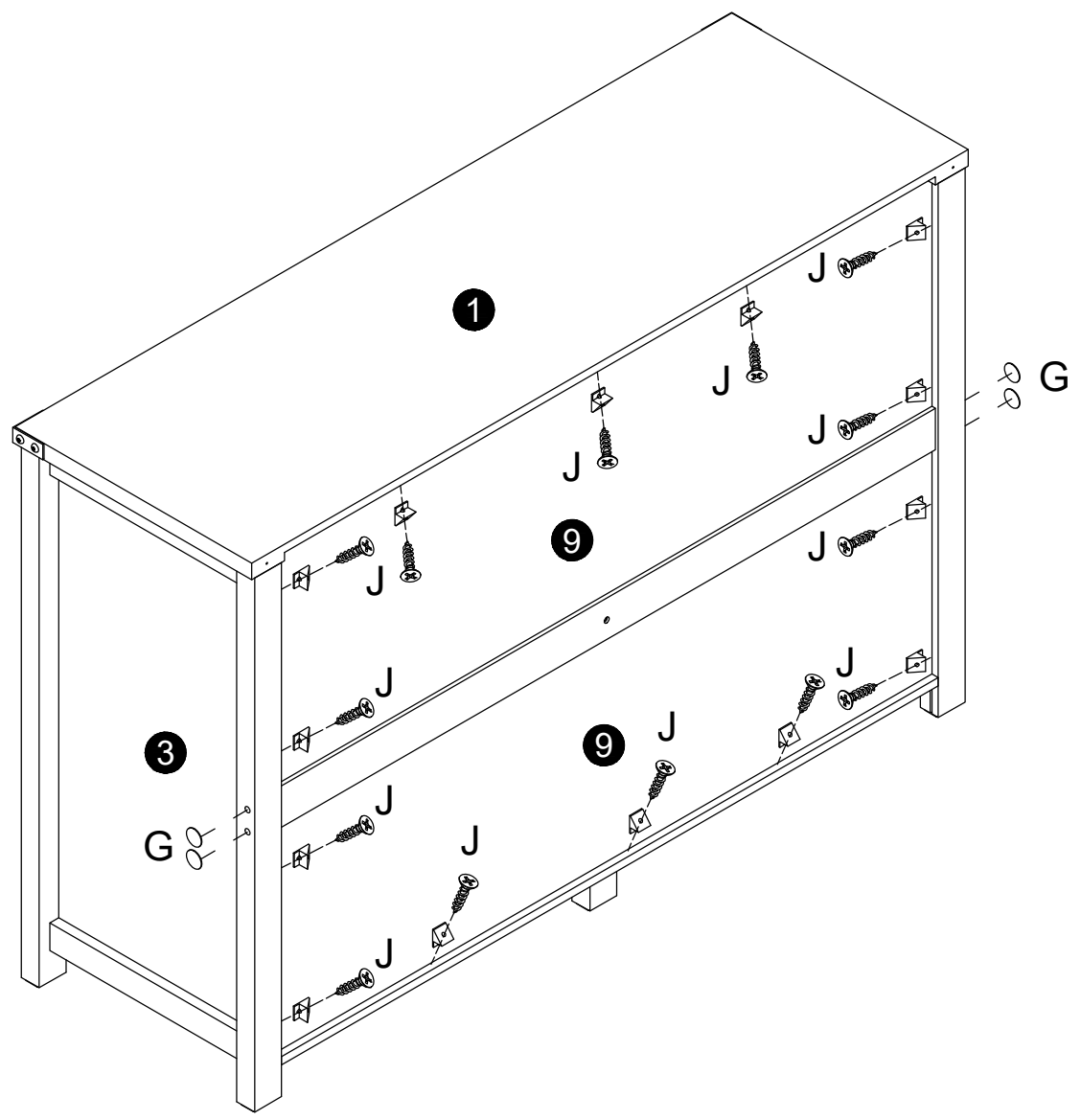

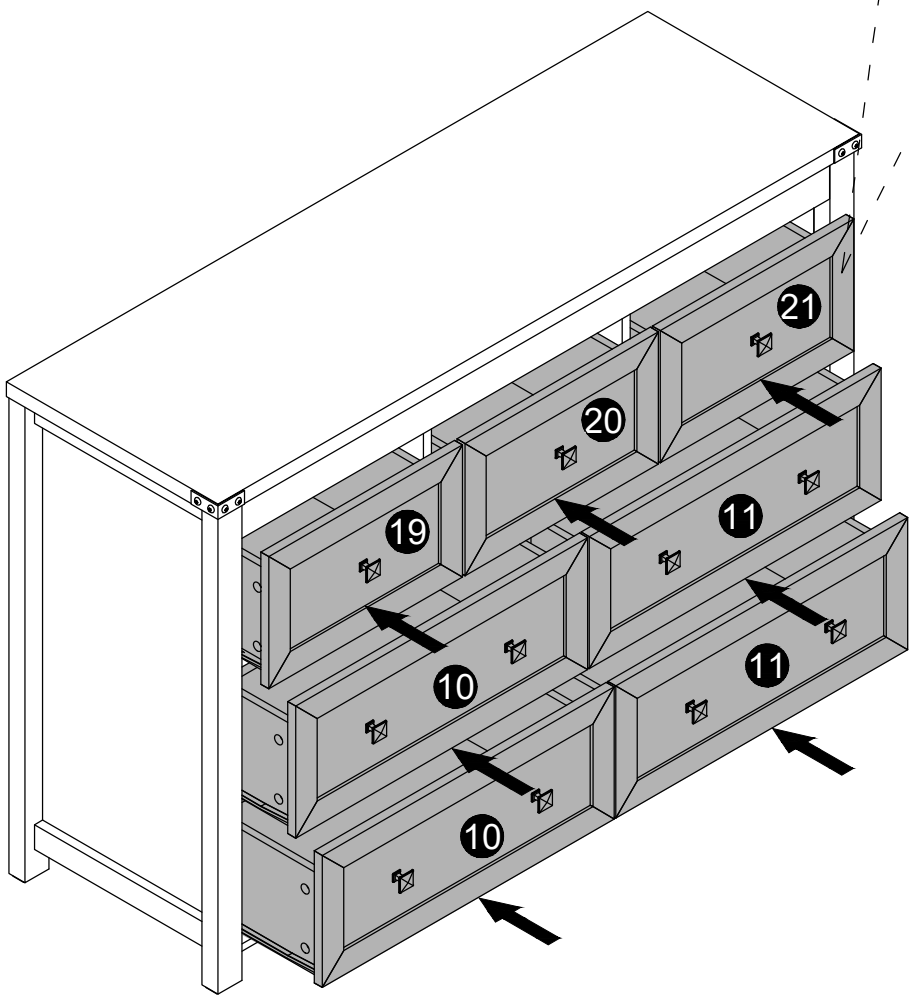
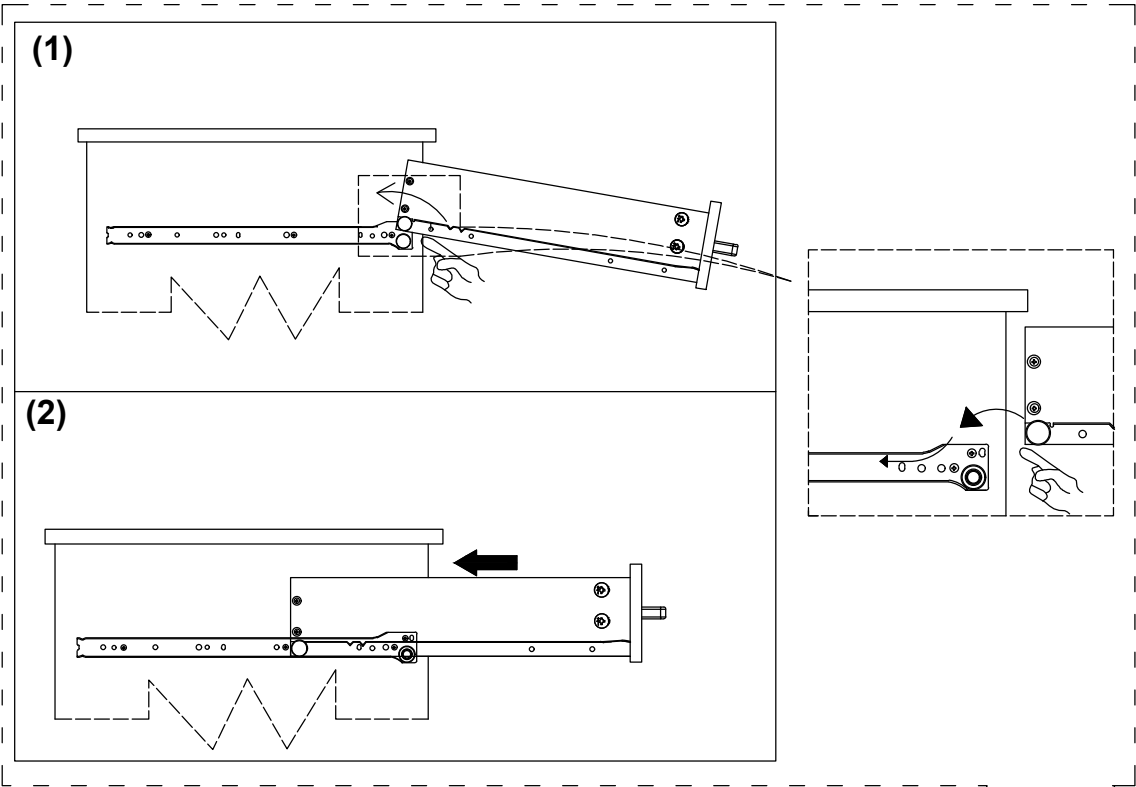

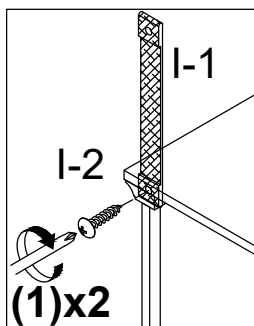
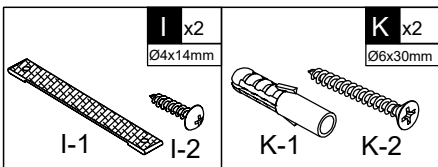

First fix the anti-rewind screw in the reserved hole of the product.

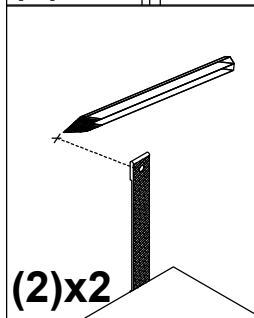

then, use a ruler to measure the approximate height of the product on the wall, and then mark it with a pen.

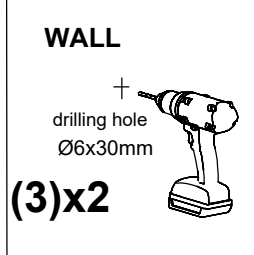

Then use a tape drill to make holes in the wall that are suitable for the product screws.

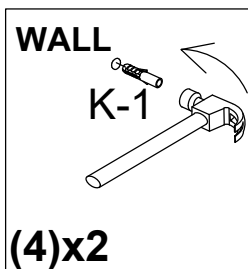

Then, put the expansion bolt into the hole

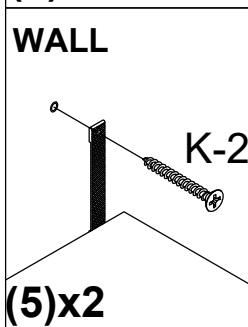

Finally, pass the matching screws through the "anti-rewind" and tighten them to fix them on the wall.

