

ASSEMBLY INSTRUCTION

This set included 2 boxex if do not receive full 2 boxex. Please contact our customer service team

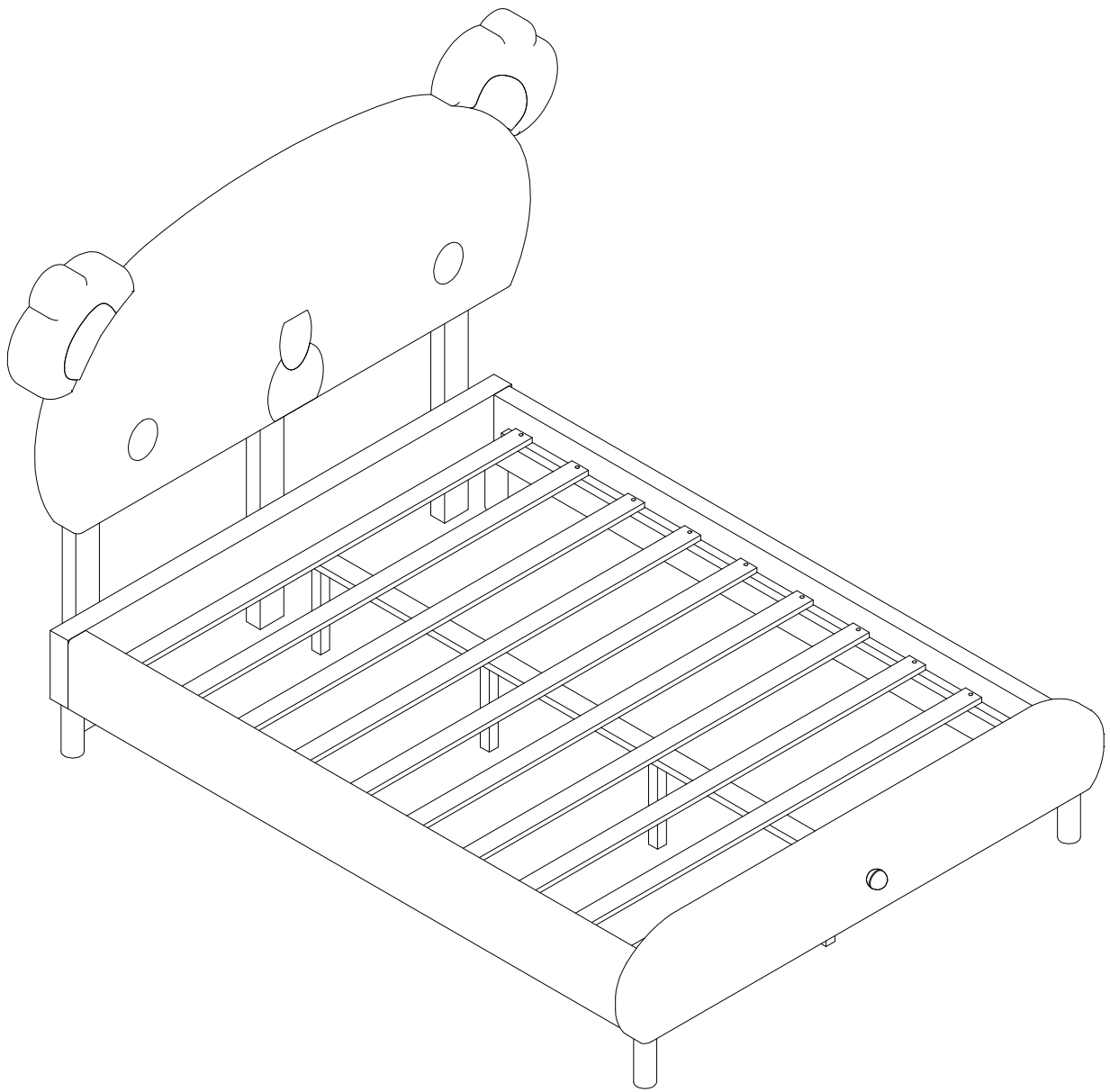

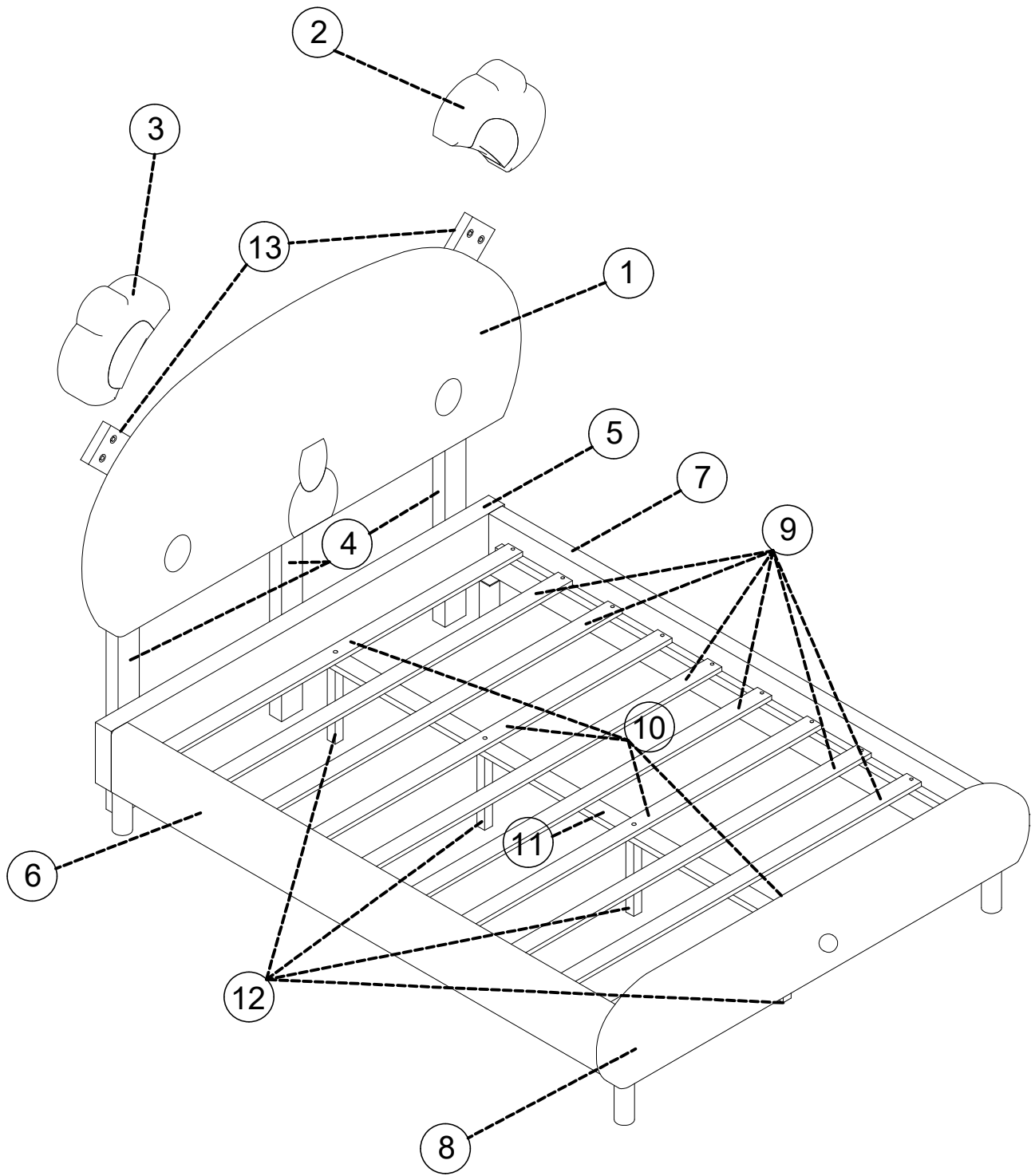

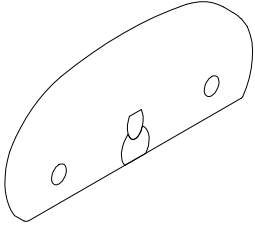
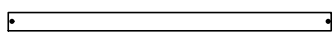
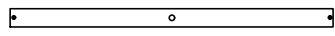
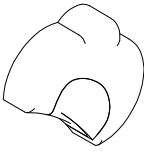
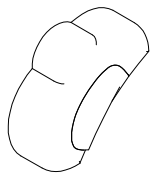

Part List

BOX 1/2

| | | |
|--|---|--|
| <p>1</p>  <p>Head board -1pc</p> | <p>9</p>  <p>Slates-6pcs</p> | <p>10</p>  <p>Slates-4pcs</p> |
| <p>2</p>  <p>Wing board Right-1pc</p> | <p>3</p>  <p>Wing board Left-1pc</p> | |

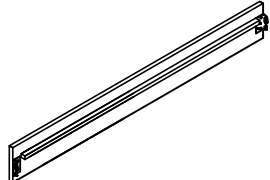
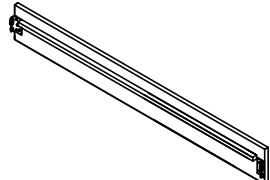
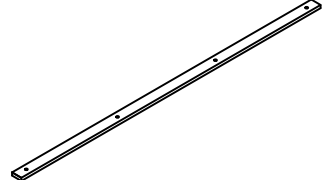
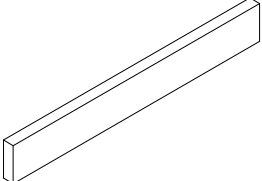
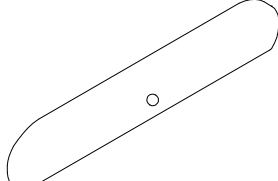
BOX 2/2

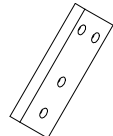
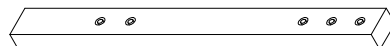
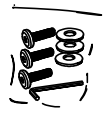

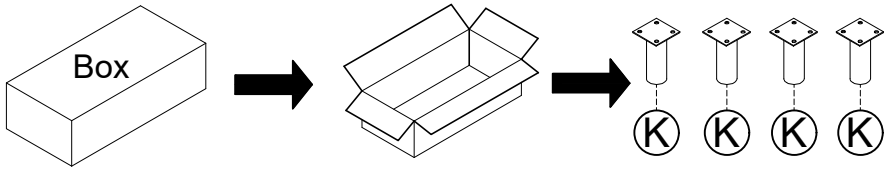





| | | |
|--|---|--|
| <p>6</p>  <p>Side rail Left - 1pc</p> | <p>7</p>  <p>Side rail Right - 1pc</p> | <p>11</p>  <p>Bed support Slates-1pc</p> |
| <p>5</p>  <p>Head board below-1pc</p> | <p>8</p>  <p>Footboard-1pc</p> | <p>12</p>  <p>Legs middle-4pcs</p> |
| <p>13</p>  <p>Connect Wing & Headboard-2pcs</p> | <p>4</p>  <p>Head board legs -3pcs</p> | <p>Hardware</p>  |

| |
|--|
| <p>K</p>  <p>Legs-4pcs</p> |
|--|



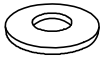

HARDWARE

Check that you've received
all hardware listed below.

Hardware List



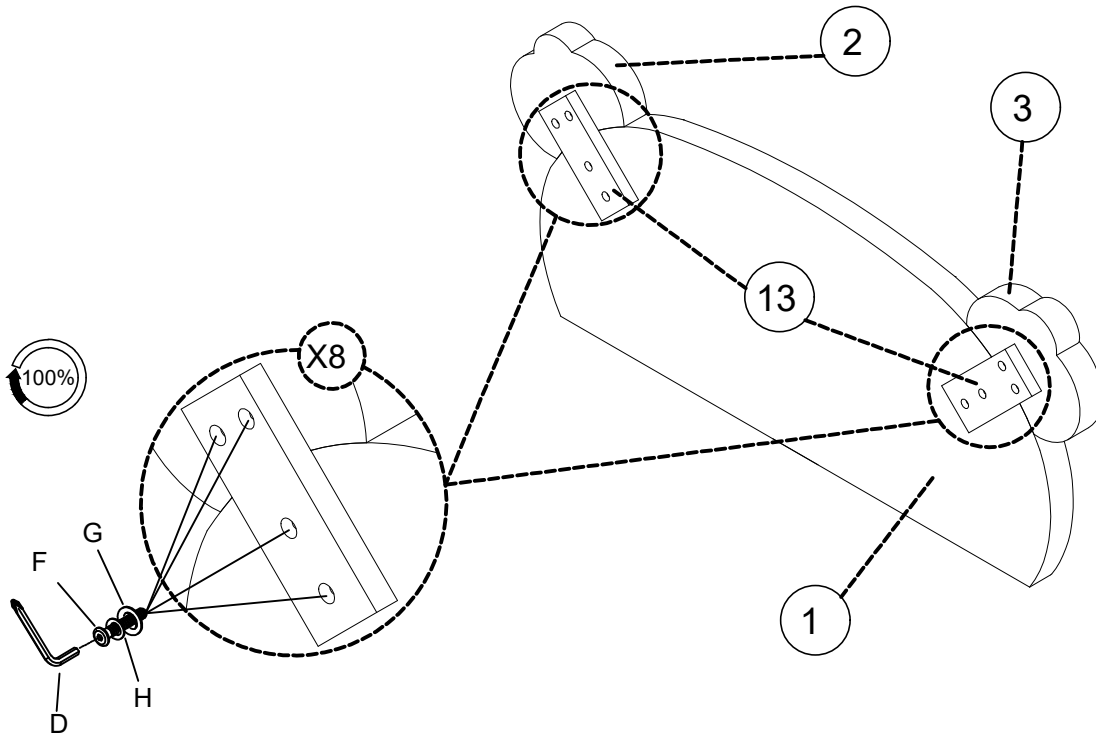

| No. | OUTLOOK | DESC | QTY |
|-----|---|-------------------------------|-----|
| (A) |  | Bolts 5/16"x30 mm | 8 |
| (B) |  | Plain washer Ø5/16"x19x1.5 mm | 27 |
| (C) |  | Spring washer Ø5/16"x12 mm | 27 |
| (D) |  | Allen key 80x30x4 mm | 1 |
| (E) |  | Bolts 5/16"x45 mm | 19 |
| (F) |  | Bolts 1/4"x30 mm | 16 |
| (G) |  | Plain washer Ø1/4"x19x1.5 mm | 20 |
| (H) |  | Spring washer Ø1/4"x10 mm | 16 |
| (I) |  | Screws Ø4x30 mm | 24 |

STEP 1

| | | | |
|---|---|---|--|
| F x 8 | G x 8 | H x 8 | D x 1 |
|  |  |  |  |



STEP 2

| | | | |
|---|---|---|--|
| E x 9 | B x 9 | C x 9 | D x 1 |
|  |  |  |  |

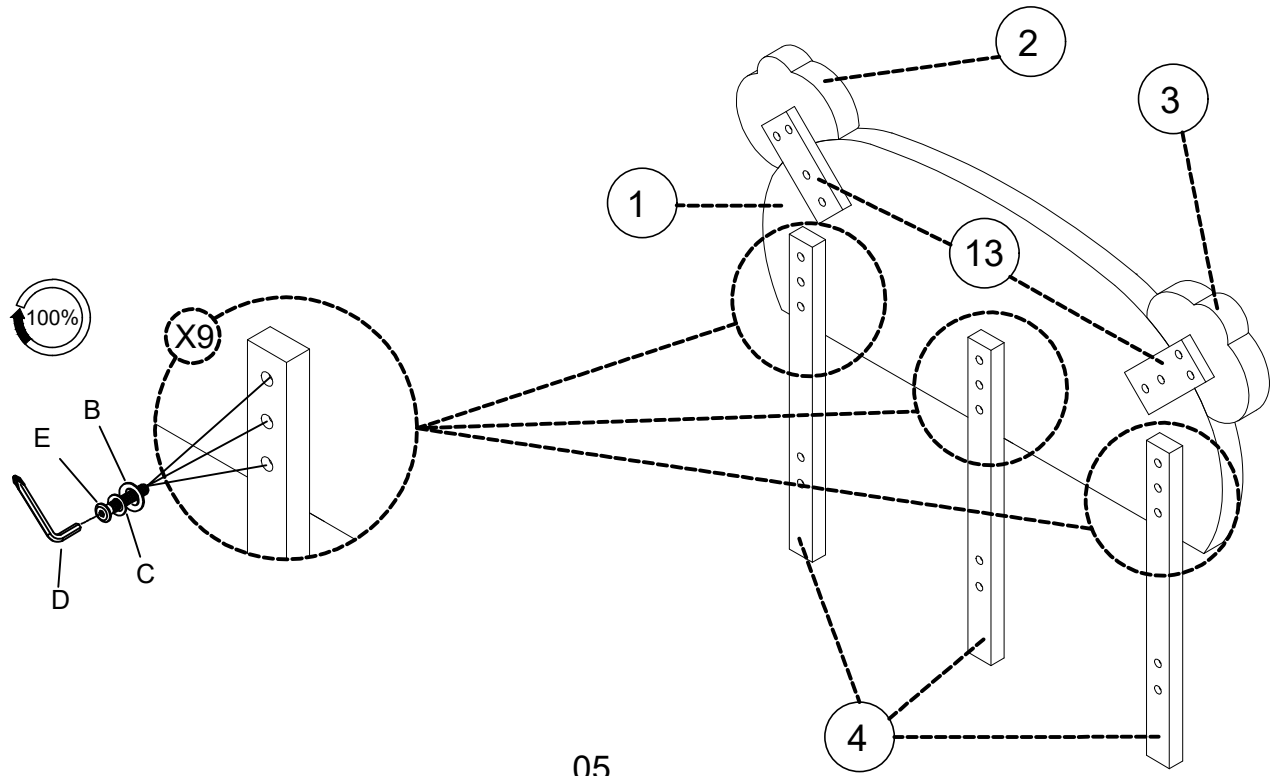



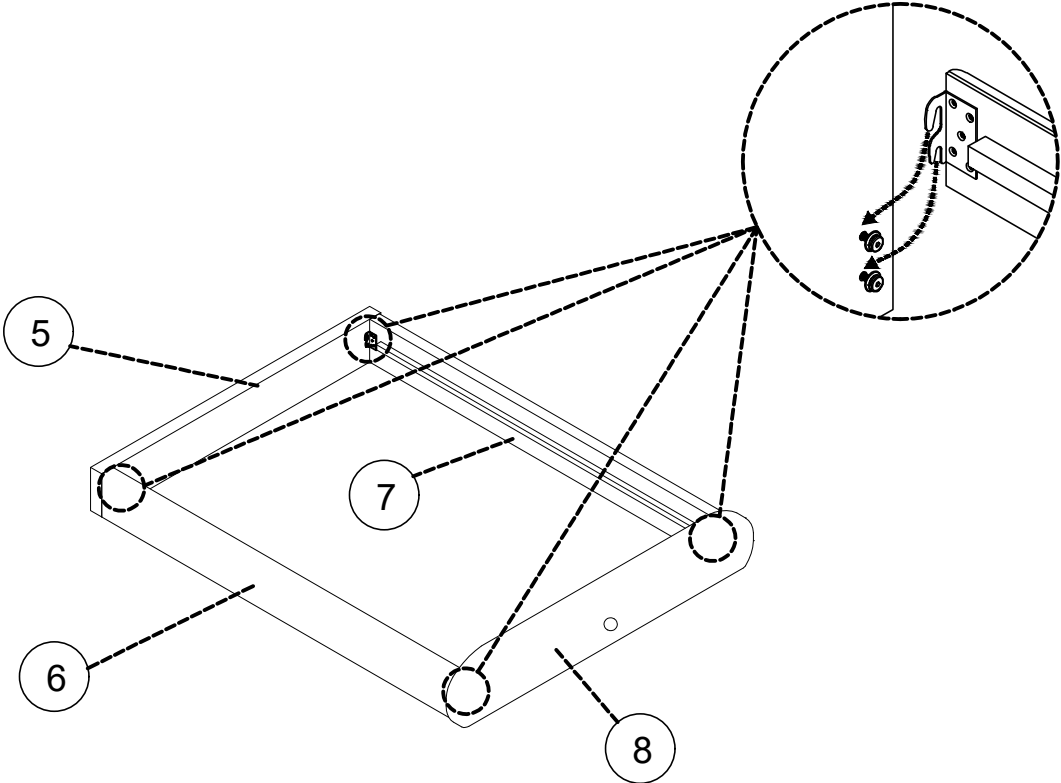

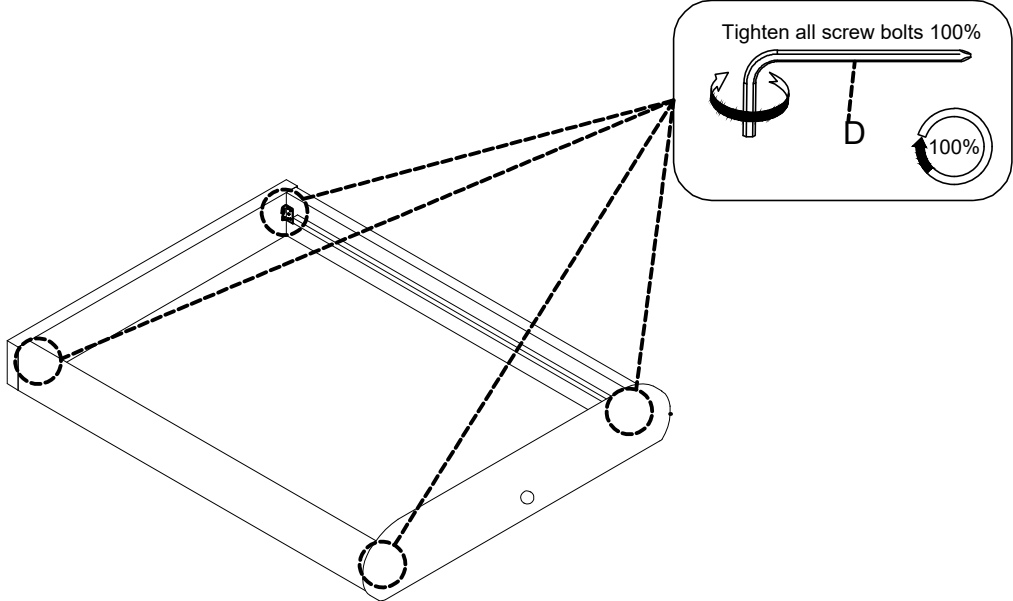

STEP 5



STEP 6





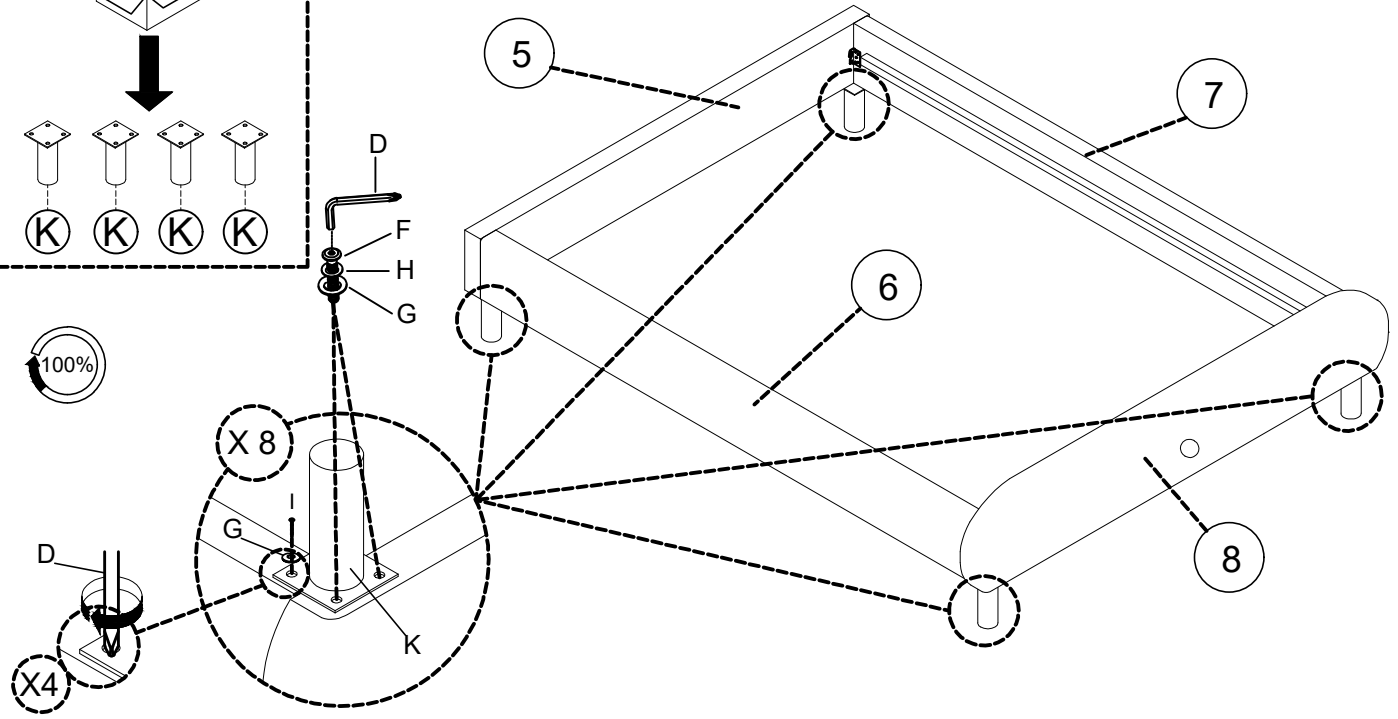
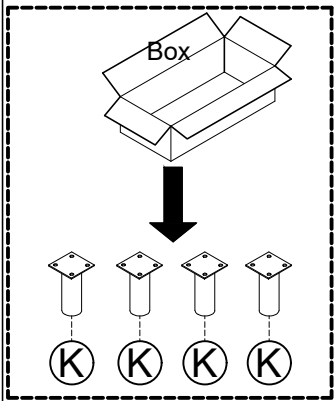

STEP 7

| | | | | | |
|--|---|--|---|--|--|
| F x 8  | G x 12  | H x 8  | D x 1  | K x 4  | I x 4  |
|--|---|--|---|--|--|



STEP 8

| | | | |
|--|--|--|---|
| E x 6  | B x 6  | C x 6  | D x 1  |
|--|--|--|---|

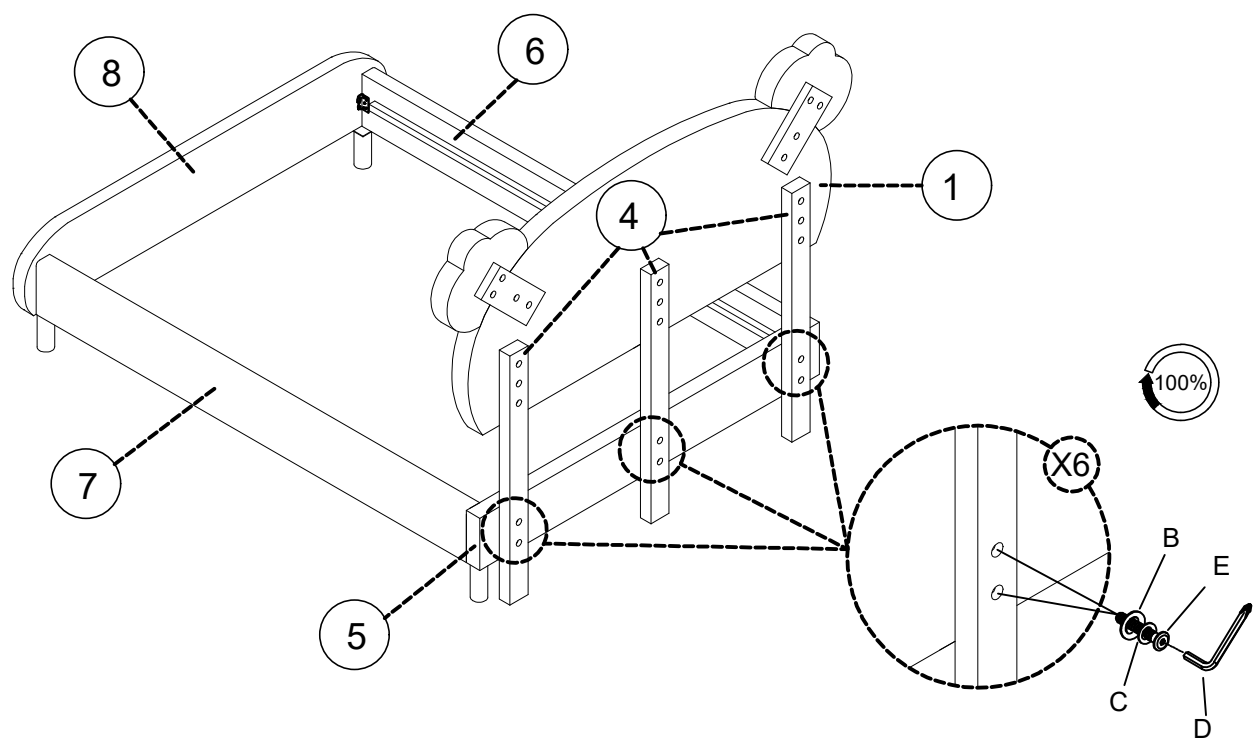

STEP 9

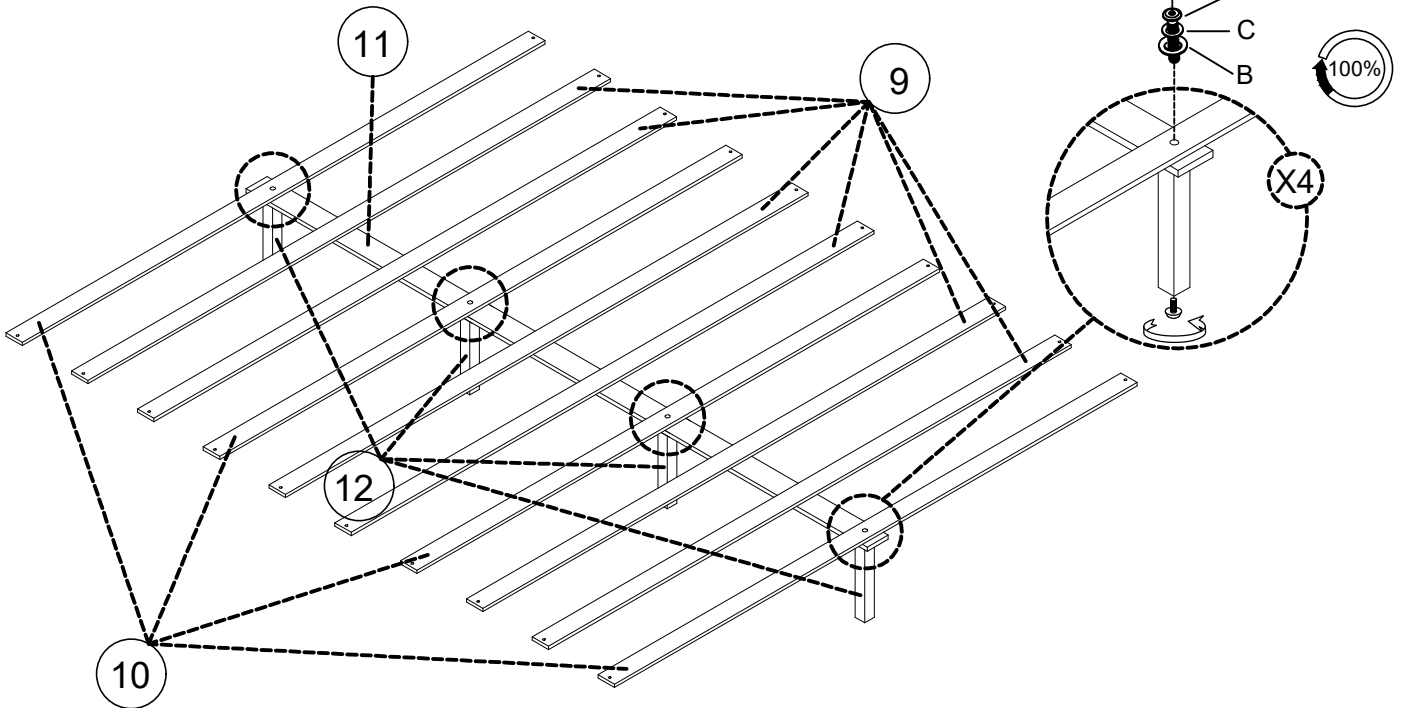
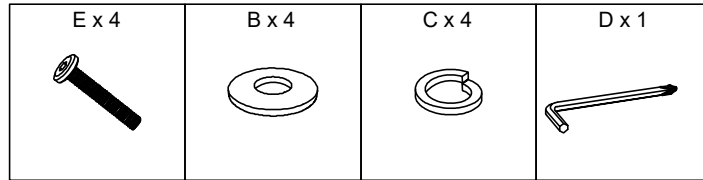

STEP 10

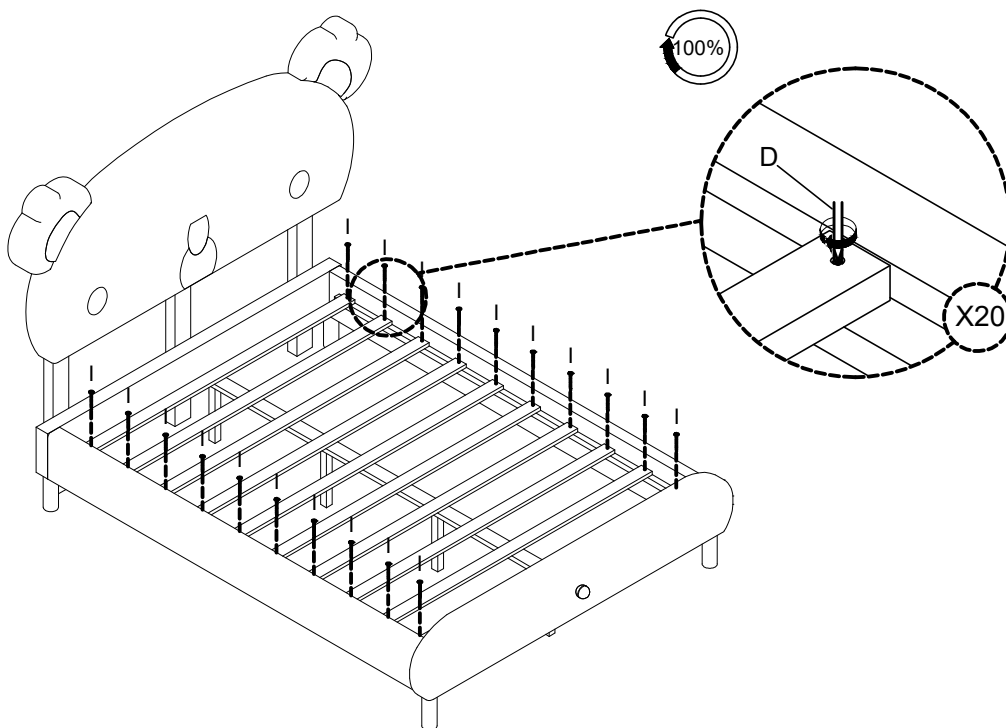
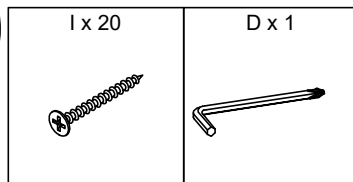

COMPLETE

