

INSTALLATION INSTRUCTION

Please watch the installation video on the details page

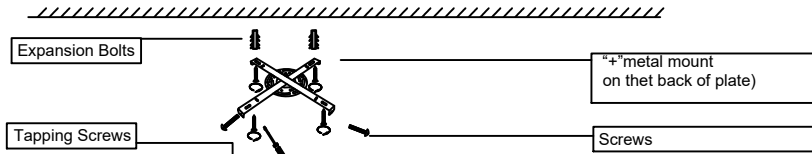

(Figure1)

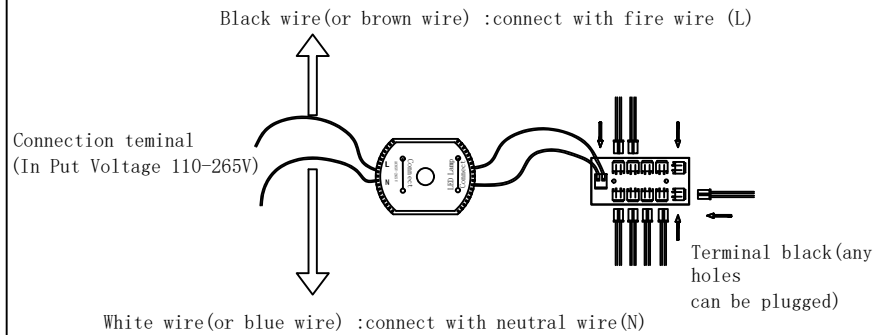

Installation Steps:

1. Install the "+" metal mount.
2. Remove the protective film wrapped on the lamp body, do not use knives or sharp instrument, so as not to scratch the light body or wire insulation layer.
3. Install SIX rings to the light fixture plate
4. Test circuit: Connect the power wires with a temporary wire for testing if the light is working properly before install it to the ceiling.
5. Installation: Fix the lamp body to the cross hardware hanger, connect the power wires with the connecting terminals.
6. Turn on the power and double check again, the installation is complete.



Warning!

- 1) Please install by professional.
- 2) The voltage available for 110-260V only.
- 3) Don't install the lighting fixture under moist condition.
- 4) Please switch off the power when you cleaning the lighting fixture.
- 5) Keep away from acidic & corrosive material.

Installation instructions for Metal mount

This job will go easier with two people, because the light needs support during assembly, and it helps having somebody to read the directions. I am referring to the acrylic pieces "the rings" and the round metal thing as "the light fixture metal plate."

<p>Threading the wire through to the double ended metal tube and Install two tubes to the ring</p>	<p>8pcs nuts</p> <p>8pcs lock washers</p>	<p>49cm</p> <p>The longer ended: install to the light fixture metal plate</p> <p>8cm double ended metal tube</p> <p>The shorter ended: install to the petals</p>	<p>26cm</p> <p>The longer ended: install to the light fixture metal plate</p> <p>6cm double ended metal tube</p> <p>The shorter ended: install to the petals</p>	<p>33cm</p> <p>The longer ended: install to the light fixture metal plate</p> <p>4cm double ended metal tube</p> <p>The shorter ended: install to the petals</p>
<p>2: Install 12 double ended metal tubes to the rings</p>				
<p>Fasten the first 33CM diameter Ring (use 4CM tubes) to the light fixture metal plate with a lock washer and a nut. The position show on the picture. It will look very flat, not 3D. Notice: Place the tubes of one ring into corresponding holes on the edge of the round metal fixture</p>	<p>Fasten the second 33CM diameter Ring (use 4CM tubes) to the light fixture metal plate with a lock washer and a nut. The position show on the picture. It will look very flat, not 3D. Notice: Place the tubes of one ring into corresponding holes on the edge of the round metal fixture</p>			
<p>Fasten the third, fourth 26CM diameter Rings (use 6CM tubes) to the light fixture metal plate with a lock washer and a nut. The position show on the picture. It will look very flat, not 3D. Notice: Place the tubes of one ring into corresponding holes on the edge of the round metal fixture</p>	<p>Fasten the fifth, sixth 19CM diameter Ring (use 8CM tubes) to the light fixture metal plate with a lock washer and a nut. The position show on the picture. It will look very flat, not 3D. Notice: Place the tubes of one ring into corresponding holes on the middle of the round metal fixture</p>			
<p>5: First: Very carefully plug the 6 tiny little plugs to the control block, any hole can be plugged. Second: after finishing install the light fixture you can install it to your ceiling.</p> <p>Notice: The lack wire (or brown wire) is connect to fire wire (L) The white wire (or blue wire) is connect to neutral wire (N)</p>	<p>Fix the light fixture to the metal mount on the ceiling.</p>			