

GEORGE FOREMAN®

LARGE CHARCOAL BARBECUE GFCSBBQL

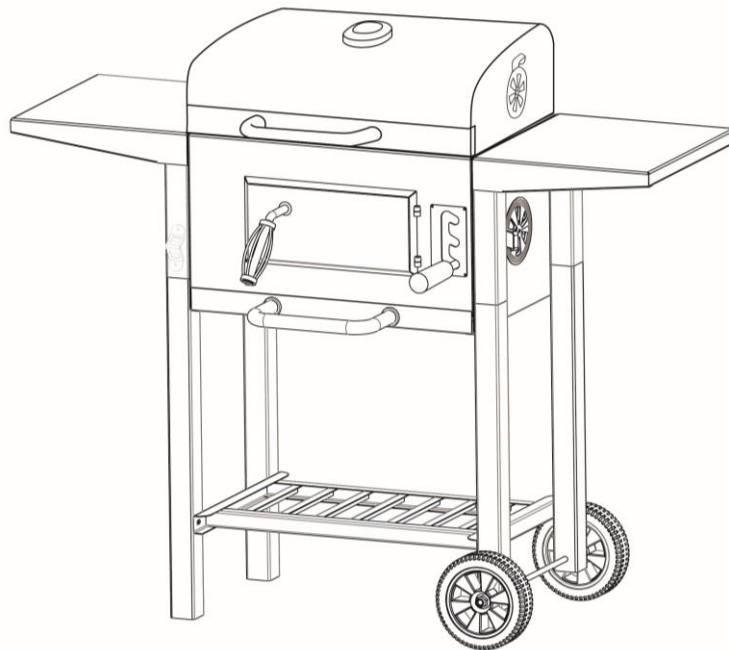

Please scan the QR code for step by step video assembly instructions. Alternatively, you can visit: bbqs.georgeforeman.co.uk. From here, please select the product that you are looking to build and view the 'How To' video located at the bottom of the page.

**WARNING: PLEASE ENSURE YOU HAVE READ
THROUGH THE SAFETY AND OPERATING
INSTRUCTIONS BEFORE USE.**

PLEASE RETAIN INSTRUCTIONS FOR FUTURE REFERENCE

CONTENTS

	Page(s)
Safety Instructions	3-5
BBQ Parts List & Feature Diagram	6-7
BBQ Assembly	8-18
Lighting your BBQ	19
Food Safety	20
Cleaning Instructions	21
Guarantee and Customer Services	22
Notes	23

SAFETY INSTRUCTIONS

WARNING: IMPORTANT SAFETY INSTRUCTIONS

READ CAREFULLY AND KEEP FOR FUTURE REFERENCE

Before you start to build and use your barbecue, please read these instructions thoroughly:

- Please dispose of all plastic bags carefully and keep them away from children.
- Check all the parts provided against the list in this instruction manual to make sure you have all of the parts listed. If not, contact your local store who will be able to help you.
- Take a few moments to familiarize yourself with the contents and before starting, check all holes are clear of any paint residue.
- When you are ready to start, make sure that you have plenty of space and a clean dry area for assembly.
- **Important** - Whilst every care is taken in the manufacture of this product, care must be taken during assembly in case sharp edges are present.

Please read and follow this advice when cooking on your barbecue:

- **ALWAYS** wash your hands before or after handling uncooked meat and before eating.
- **ALWAYS** keep raw meat away from cooked meat and other foods.
- Before lighting your BBQ, ensure grill surfaces and tools are clean and free of old food residues.
- **DO NOT** use the same utensils to handle cooked and uncooked foods.
- Ensure all meat is cooked thoroughly before eating.
- **CAUTION** - eating raw or under cooked meat can cause food poisoning (e.g. bacteria strains such as E.coli).
- To reduce the risk of undercooked meat, cut it open to ensure it is cooked all the way through internally before consuming.
- **CAUTION** - if meat has been cooked sufficiently the meat juices should be clear in colour and there should be no traces of pink/red juices or meat colouring.
- After cooking with your BBQ always clean the grill cooking surfaces and utensils.

SAFETY INSTRUCTIONS

Safety Warnings:

- **WARNING** - This barbecue will become very hot, do not move it during operation.
- **WARNING** – Charcoal BBQ's give off **CARBON MONOXIDE** when used, which is poisonous and can kill. **DO NOT** use a BBQ indoors or either in a tent, caravan or awning.
- **WARNING** - Do not use indoors! **OUTDOOR USE ONLY**. Do not use the BBQ in a confined and/or habitable space e.g. houses, tents, caravans, motor homes, boats. Danger of carbon monoxide poisoning fatality.
- **DO NOT** use this product as a furnace.
- Ensure that the product is positioned on a permanent, flat, level, heat resistant, non-flammable surface always from flammable items, including wooden fences or overhanging trees.
- Ensure the product has a minimum of 2 meters overhead clearance and has a minimum of 2 m clearance from other surrounding items.
- **WARNING!** Do not use spirit or petrol for lighting or relighting! Use only firelighters complying to EN 1860-3!
- **NEVER** leave a burning fire unattended.
- **WARNING** - Keep children and pets away. Children must not operate or play near this barbecue.
- **DO NOT** cook before the charcoal has a coating of ash.
- **WARNING** - Failure to follow instructions could result in death, serious bodily injury and/or property loss.

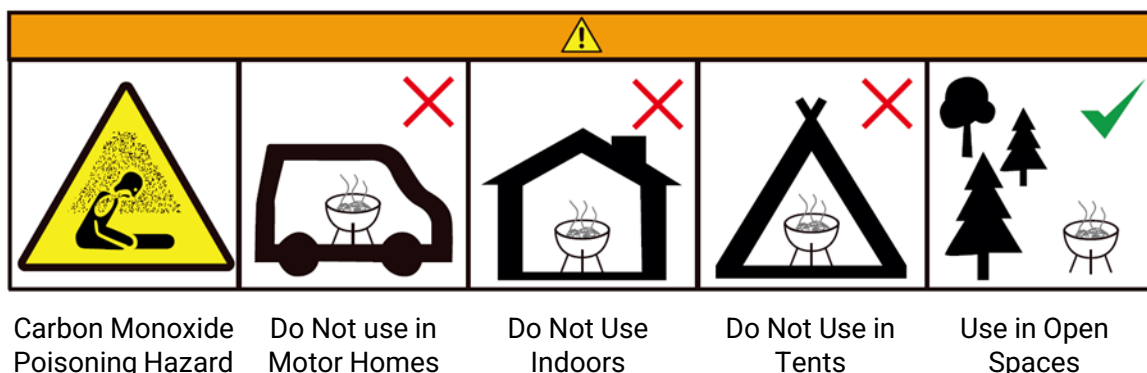











SAFETY INSTRUCTIONS

- The barbecue must be placed on a secure level base during use.
- The barbecue should be heated up for at least 30 minutes prior to the first cooking on the barbecue.
- Ensure that the coals placed do not exceed a single layer on the adjustable charcoal tray.
- The barbecue must never be left unattended during operation or cleaning.
- **DO NOT** wear loose clothing, and ensure that long hair is tied back when around the barbecue when it is hot or in use.
- Make sure that the barbecue is always placed on a firm, level and fire retardant surface, and also placed far away from combustibles.
- The barbecue should be located in an open area with good ventilation, away from trees and fences.
- **DO NOT** use the barbecue in high wind.
- While every effort has been made in the manufacture of your barbecue to remove any sharp edge, you should handle all components with care in order to avoid accidental injury.
- If the fire flares up due to dripping fat then douse the flames lightly with a fine water spray.
- Do not overload or use this barbecue to burn leaves, household waste, or paper.
- Keep fire extinguisher within safe and accessible distance and make sure those operating the barbecue are trained to use it.
- Keep away from flammable material and fluids such as petroleum, alcohol, diesel fuel, kerosene and charcoal lighter fluid or vehicles while in use. Do not use these materials to light or relight also.
- **DO NOT** store the barbecue until the fire is completely out and surfaces are cold; also do not store the barbecue with ashes or combustible materials inside.

BBQ PARTS LIST

PART	DESCRIPTION	QTY
1	Main body	1
2	Air vent	4
3	Left bottom legs	2
4	Right bottom legs	2
5	Bottom shelf	1
6	Wheel	2
7	Wheel axle	1
8	Side shelf	2
9	Adjustment pole handle	1
10	Adjustment pole	1
11	Adjustable charcoal tray	1
12	Handle with end caps	2
13	Goor handle	1
14	Door	1
15	Bottle opener	1
16	Ash tray	1
17	Upper cooking grid	1
18	Cooking grid	2
19	Adjustment pole bracket	1

PART	IMAGE	DESCRIPTION	QTY
A		M6X12 Bolt	20
B		M5X10 Bolt	4
C		M5 Washer	4
D		M5 Nut	4
E		M8 Nut	2
F		M8 Washer	2
G		M6X18 Bolt	1
H		M5X15 Bolt	6
I		M6X15 Bolt	1
J		M6 Nut	1
K		Pin Bolt	1

You will also need (not included):



Phillips head screwdriver



Adjustable wrench

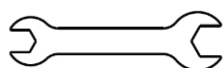

Wrench

ATTENTION: Check that all parts listed on this page are present prior to assembly

FEATURE DIAGRAM

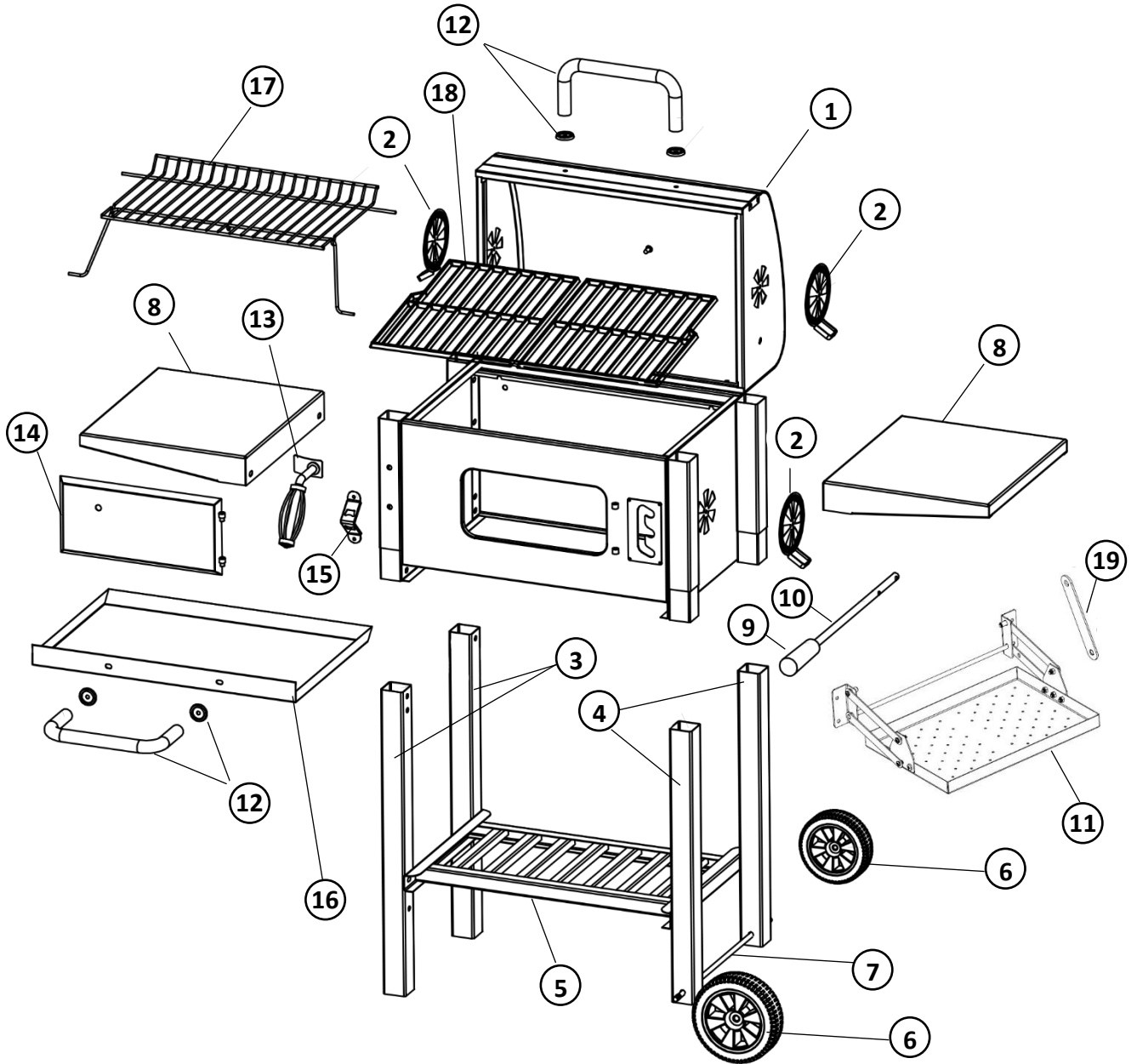





BBQ ASSEMBLY

STEP 1 – Attaching the vents

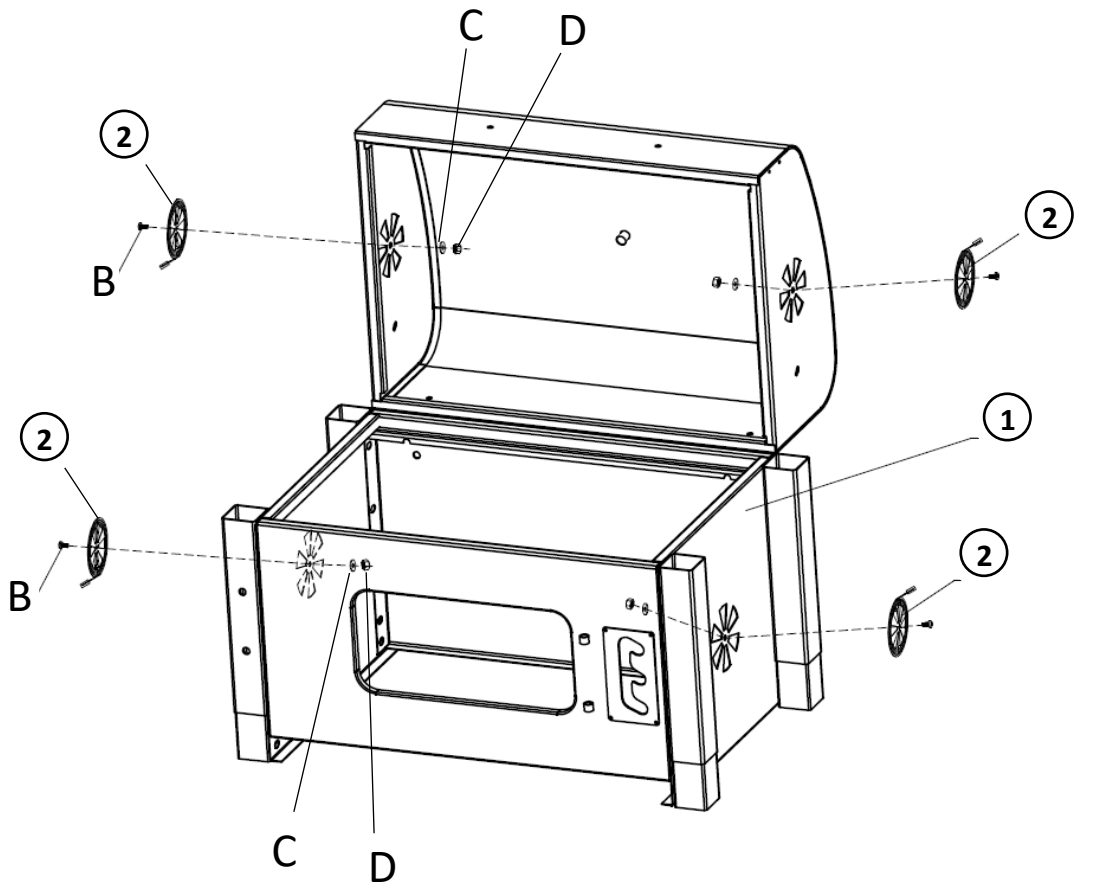
- Attach the **air vents** (2) onto the **main body** (1), using 4 each of the “**B**” Screws, “**C**” Washers, and “**D**” Nuts.

Ensure the screws are placed on the outside of the main body and the nuts and washers are placed on the inside of the main body.



B		4 PCS
C		4 PCS
D		4 PCS

BBQ ASSEMBLY

STEP 2 – Attaching the legs

- Lay the **main body** (1) on a flat surface as shown below and attach the **left bottom legs** (3) and **right bottom legs** (4) onto the **main body** (1). Secure in place using 8 each of the “A” Screws, as displayed in the diagram below.

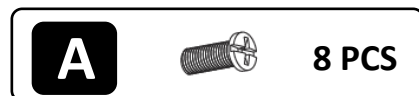
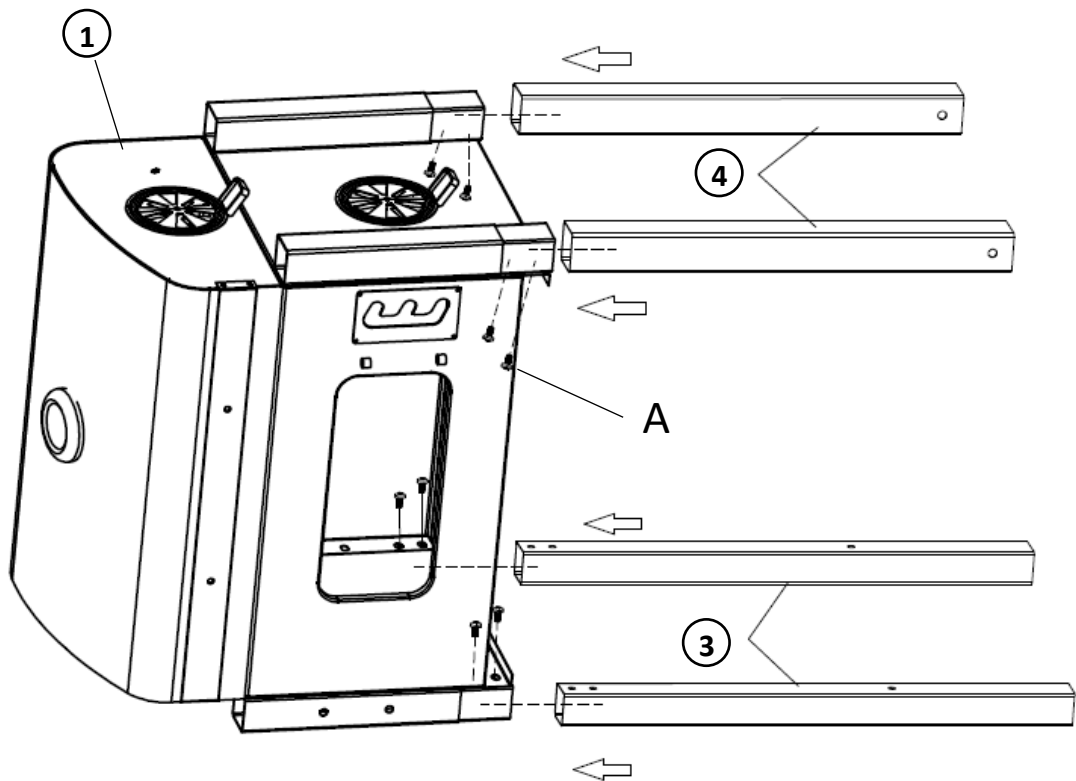

BBQ ASSEMBLY

STEP 3 – Attaching the bottom shelf

- Secure the **bottom shelf (5)** to the **left bottom legs (3)** and **right bottom legs (4)**, using 4 each of the “**A**” Screws, as displayed in the diagram below.

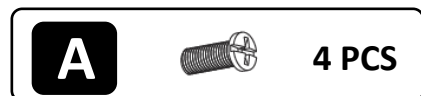
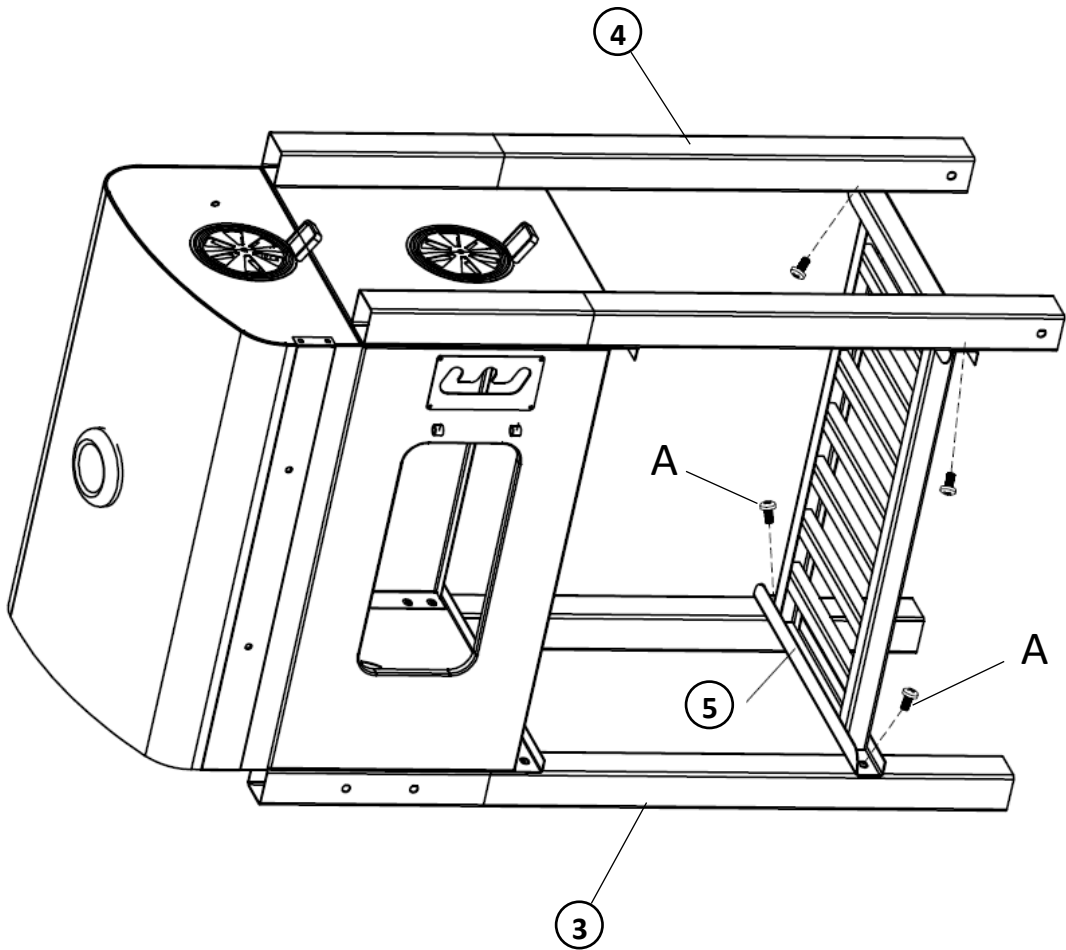



BBQ ASSEMBLY

STEP 4 – Attaching the wheels

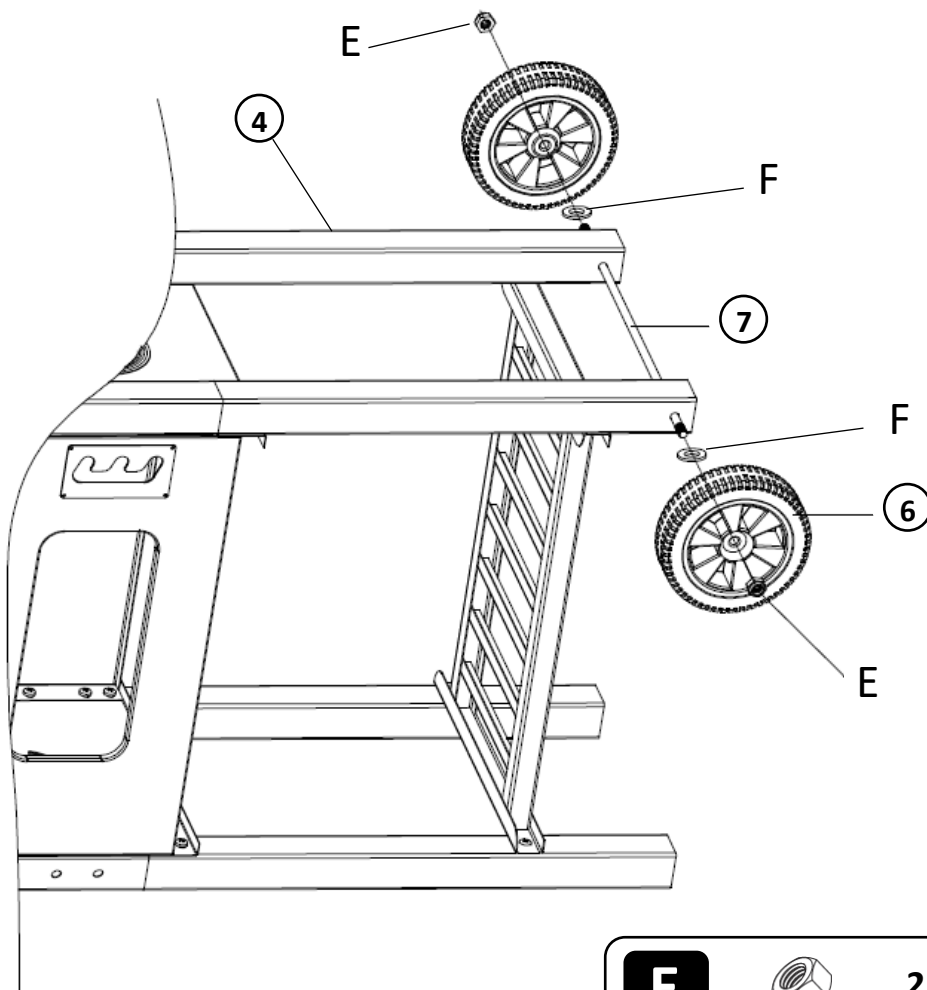
- Place one **wheel** (6) onto the **axle** (7), and then secure in place with 1 each of the “**F**” Washers and “**E**” Nuts.
- Then place the axle through the provided holes on **right bottom legs** (4), as shown in the diagram below.
- Place the remaining **wheel** (6) onto the other end of the **axle** (7), and secure using 1 each of the “**F**” Washers and “**E**” Nuts, as shown in the diagram below.



E		2 PCS
F		2 PCS

BBQ ASSEMBLY

STEP 5 – Attaching the shelves

- Attach the **shelves** (8) onto the **main body** (1) by sliding them onto the upper legs as shown. Secure in place using 4 each of the “A” Screws, as displayed in the diagram below.

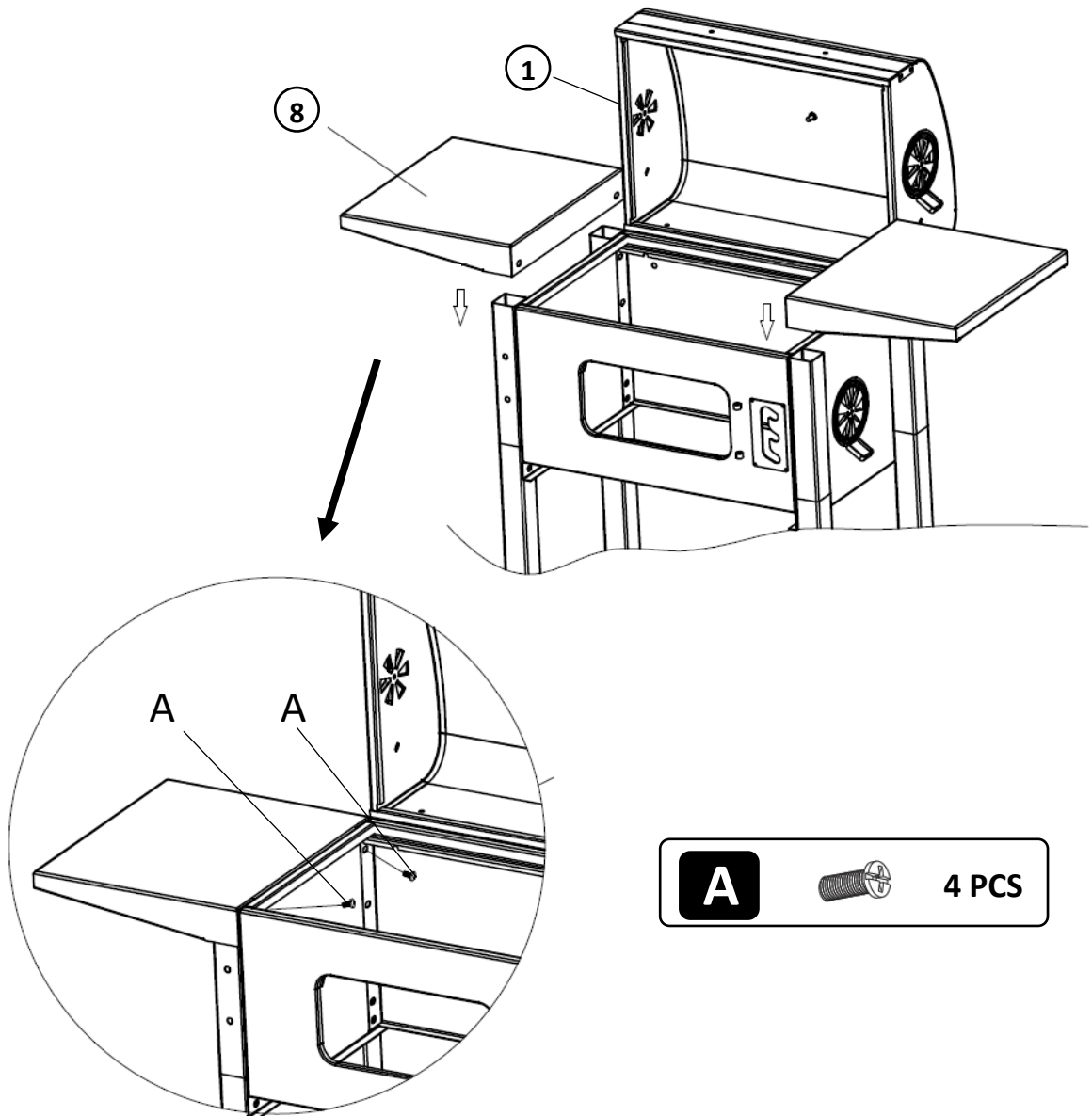

BBQ ASSEMBLY

STEP 6 – Attaching the adjustment pole

- Screw the **Adjustment Pole Handle** (9) onto the **Adjustment Pole** (10).
- Place the assembled adjustment pole through the correct gap on the front of the **Main Body** (1) as shown below, and secure using 1 **“K” Pin Bolt**. This can be done by threading the bolt through from left to right and securing with the pin, also shown below.
- Secure the **Adjustment Pole Bracket** (19) to the **Adjustment Pole** (10) using 1 **“G” Bolt**, as displayed in the diagram below.

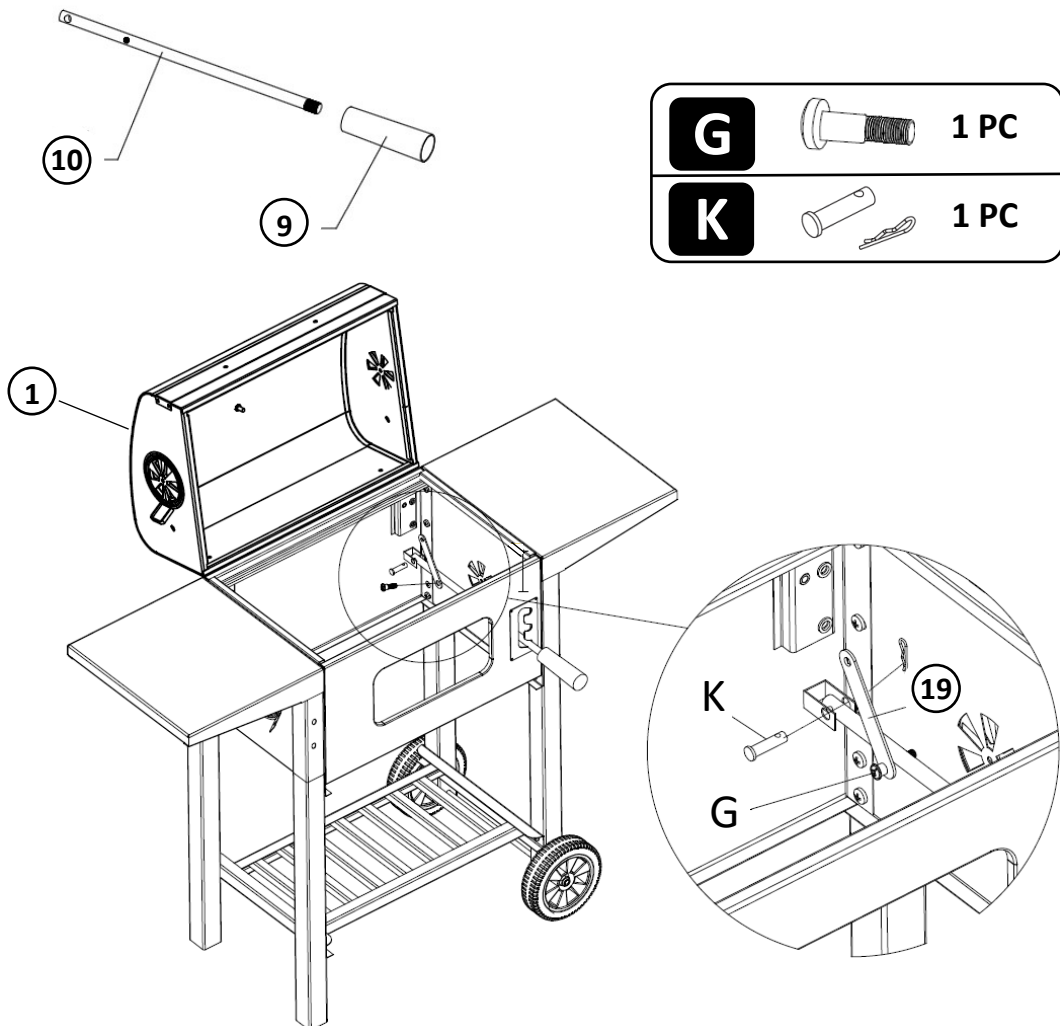

BBQ ASSEMBLY

STEP 7 – Inserting the charcoal tray

- Insert the **Adjustable Charcoal Tray (11)** into the **Main Body (1)** as shown below.

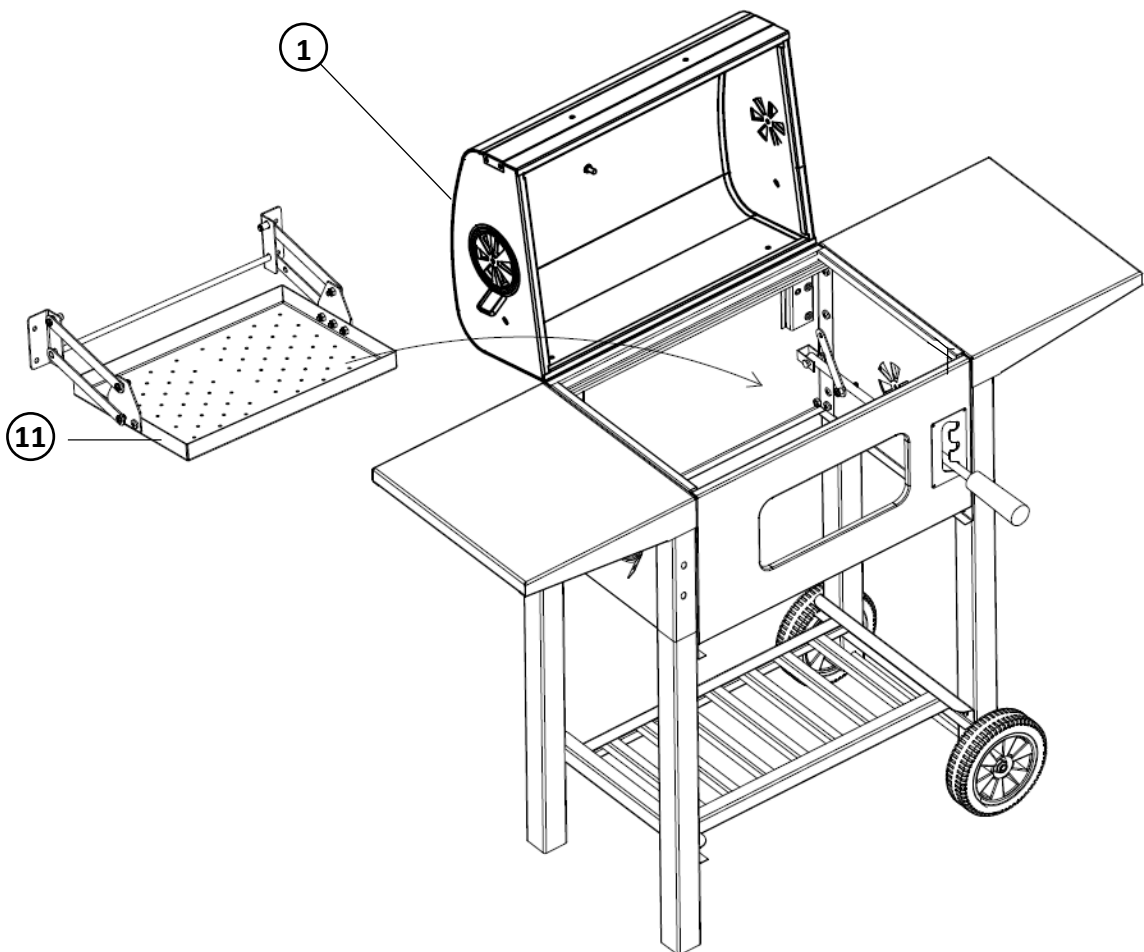



BBQ ASSEMBLY

STEP 8 – Securing the charcoal tray

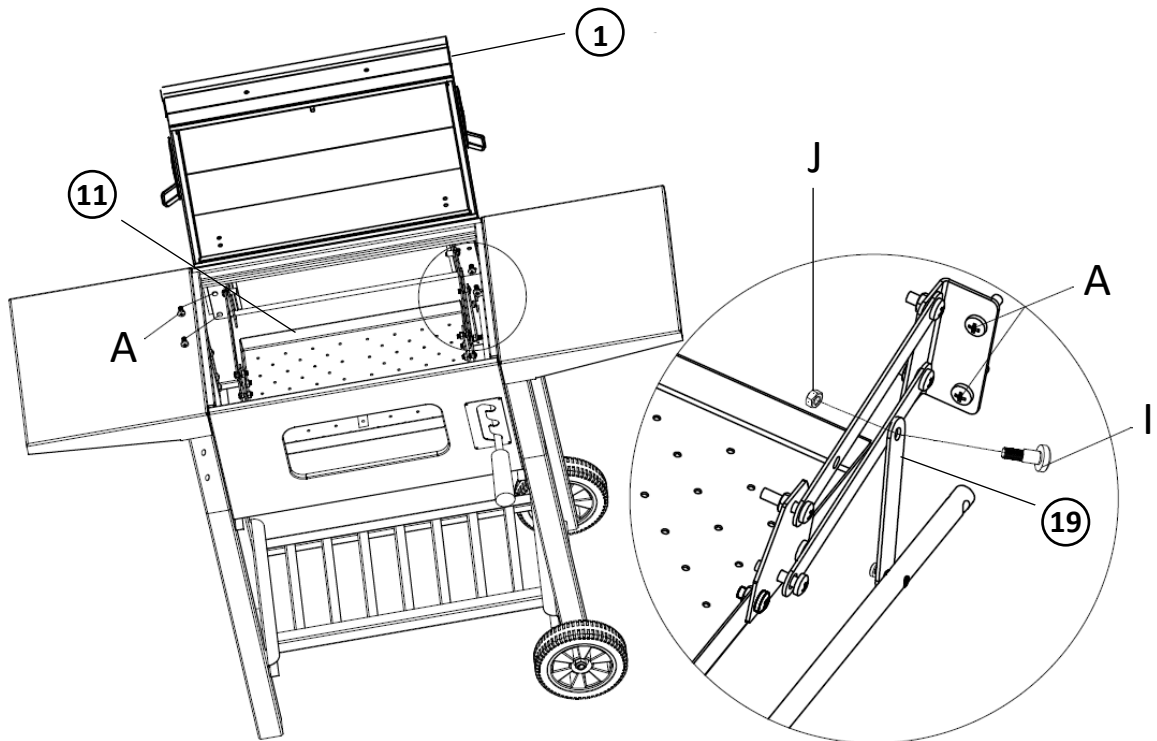
- Secure the **Adjustable Charcoal Tray (11)** to the **Main Body (1)**, using 4 each of the **“A”** Screws, as displayed in the diagram below.
- Then use the **Adjustment Pole Bracket (19)** to secure the assembled adjustment pole to the brackets on the side of the **Adjustable Charcoal Tray (11)**, using 1 each of the **“I”** Bolts, and **“J”** Nuts, as displayed in the diagram below.

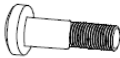

A		4 PCS
I		1 PC
J		1 PC

BBQ ASSEMBLY

STEP 10 – Attaching the bottle opener

- Secure the **Bottle Opener** (15) onto the front left leg using 2 each of the “**H**” bolts.

Ensure the bottle opener is correctly aligned before securing; the bottle opener should be flat along the top, and then angled towards the leg underneath.

- Slide the constructed ash tray into the space at the bottom of the main body.

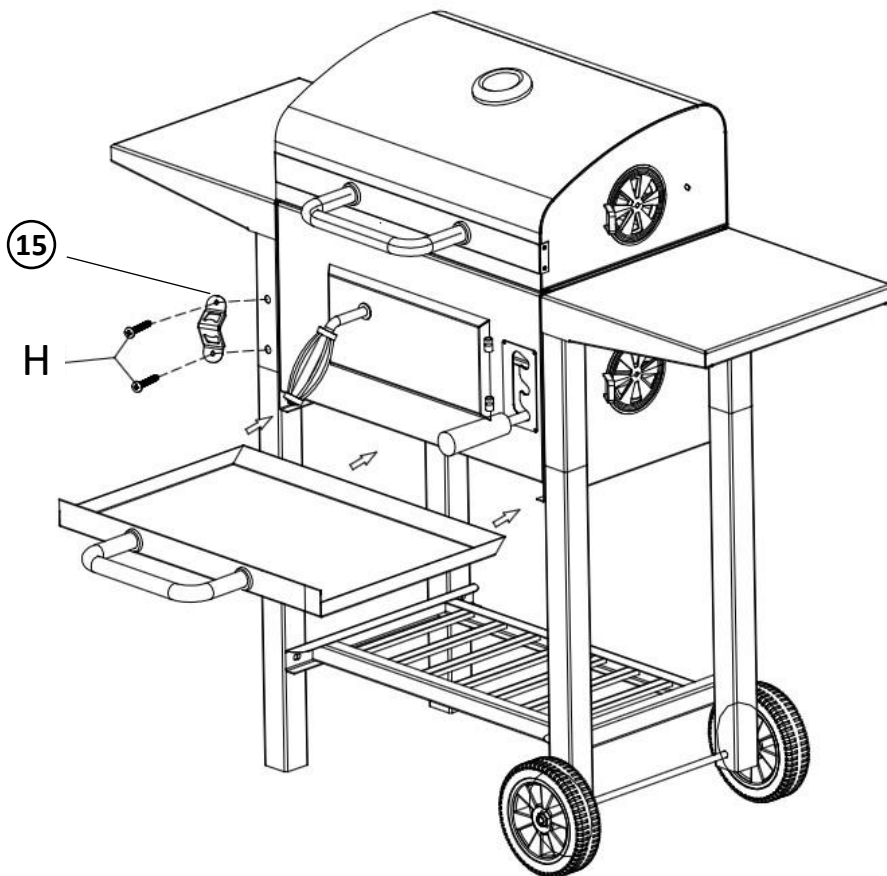
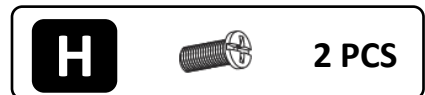

BBQ ASSEMBLY

STEP 11 – Inserting the grills

- Insert the **Upper Cooking Grid (17)**, into the **Main Body (1)** by securing it in the holes supplied, as shown in the diagram below.
- Then insert both of the **Cooking Grids (18)**, into the **Main Body (1)**, as demonstrated in the diagram below.

Your BBQ is now assembled.

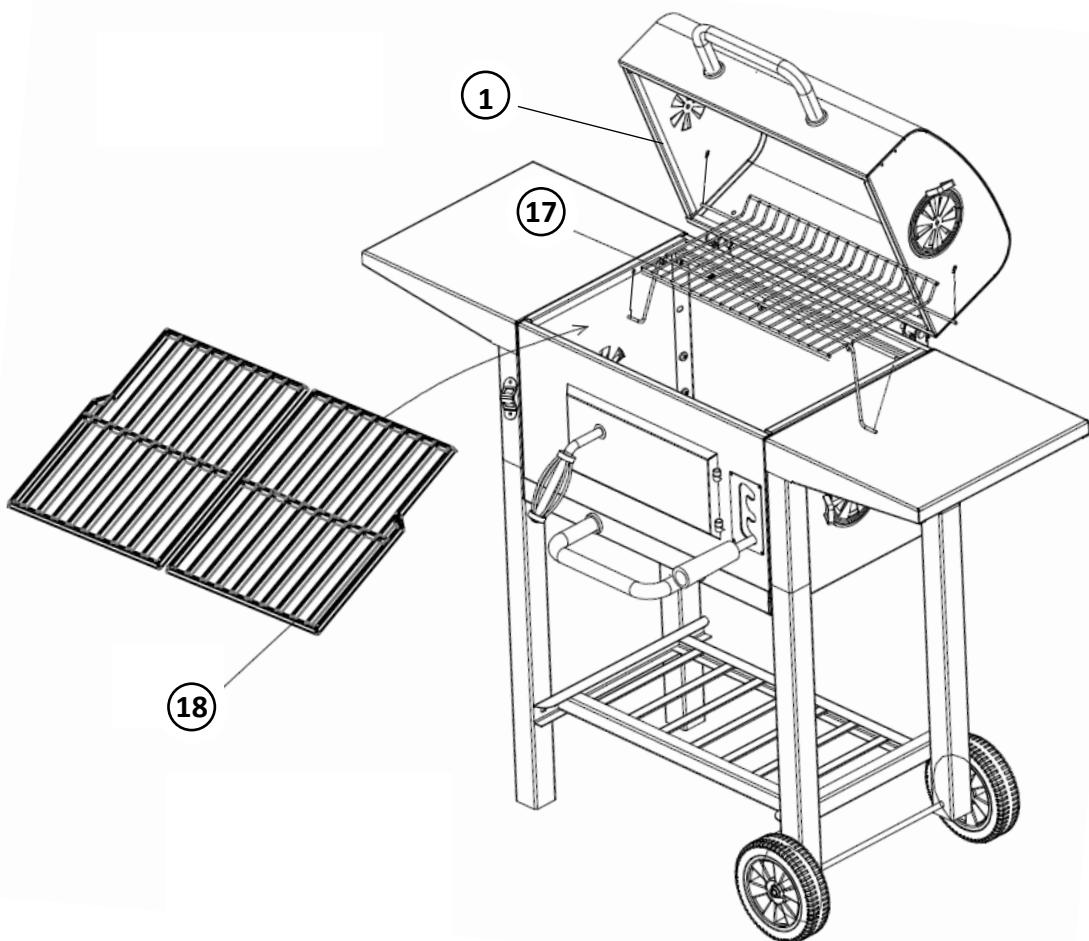

LIGHTING YOUR BBQ

WARNING! Do not use spirit or petrol for lighting or re-lighting. Use only firelighters complying to EN 1860-3.

1. Ensure the **air vents** (2) on the main body of the BBQ are closed.
2. Remove the **cooking grids** (18) and place a small quantity of charcoal onto the **adjustable charcoal tray** (11). Light in accordance with the instructions on the charcoal pack.
3. When the charcoal becomes red hot, add more charcoal for cooking. Do not overfill the tray; a single layer of charcoals is enough.
4. Wait approximately 15 minutes before placing the cooking grid on to start cooking. Do not cook before the charcoal has a coating of ash.
5. To extinguish, wait for the charcoal to stop burning and for it to completely cool.

WARNING: When using your barbecue for the first time, allow the charcoal to remain red hot for an additional 15 minutes before cooking.

WARNING: Accessible parts will be hot – avoid touching the BBQ while hot, however if it is necessary, make sure to wear oven gloves when touching the barbecue.

WARNING: Do not extinguish with water as this may damage the barbecue.

FOOD SAFETY

- Thoroughly defrost frozen meat and poultry in the refrigerator before cooking. Keep raw meat and poultry separate from cooked foods.
- Always wash hands after handling raw meat and poultry, before handling any ready to eat foods.
- Wipe and disinfect surfaces that have been in contact with raw meat and poultry.
- When barbecuing meat and poultry, make sure the barbecue is extremely hot. Place the larger, thicker portions furthest away from the most intense heat to ensure thorough cooking without burning and turn regularly.
- Use separate utensils for handling raw meat/poultry and cooked food on the barbecue, or wash them thoroughly between uses.
- To check whether meat, particularly poultry, is cooked, pierce the flesh with a skewer or fork; the juices should run clear. Ensure the product is piping hot throughout.

CLEANING AND CARE

WARNING: Ensure the appliance is cold before cleaning.

Removing the ash:

- Allow the barbecue and ash to become completely cold before emptying.
- Remove the cooking grids to ensure easy removal of the charcoal from the adjustable charcoal tray.
- Remove the ash tray from the main body of the BBQ and safely dispose of the cold ash in a fire proof container, or dampen with water to ensure the ash is entirely cold before disposing in a suitable container.

Care and Maintenance:

- Empty the ash from the barbecue and clean after each use.
- The cooking grids, and charcoal tray can be cleaned using a dishcloth, warm water, and a commercial detergent.
- Avoid using abrasive cleaners, wire wool, and brushes as these may scratch the surface.
- When not in use this barbecue should be stored in a dry location, such as a garage or shed, or under a waterproof cover.

GUARANTEE AND CUSTOMER SERVICES

This product is guaranteed for **12 months** from the date of the original purchase. If any defect arises due to faulty materials or workmanship, the faulty product must be returned to the place of purchase. Refund or replacement is at the discretion of the retailer.

The following conditions apply:

- The product must be returned to the retailer with the original proof of purchase.
- The product must be installed and used in accordance with the instructions contained in this instruction guide and any other instructions for use which are supplied.
- It must be used for domestic purposes only and for its intended use.
- This warranty does not cover wear and tear, damage, misuse or consumable parts.

This does not affect your statutory rights.

Customer Services & Spare Parts:

Region	Contact
UK & Northern Ireland	0345 209 7461
Ireland	1 800 938982
Rest of Europe	europa@productcaregroup.com

NOTES

GEORGE FOREMAN®

LARGE CHARCOAL BARBECUE GFCSBBQL

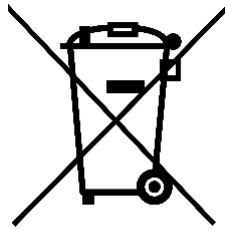

Made by . Product Care Trading Ltd, Unit 1,
Green Bank Business Park, Swan Lane,
Hindley Green, Wigan, WN2 4AY, United
Kingdom / Product Care (Ireland) Ltd, Unit 3D
North Point House, North Point Business Park,
New Mallow Road, Cork, T23 AT2P, Ireland.

George Foreman is the registered trademark
of Spectrum Brands (U.K.) Ltd.

Revision 1.6