



CARRO

INSTALLATION INSTRUCTIONS

CARROHOME.COM

MANUFACTURING QUALITY
CEILING FANS SINCE FOREVER.

Important: Please read and save these instructions before installation

Basic Product Specifications

Model	YDC523N4L-FM	Voltage	120V
Fan Blade Span	52"	Rated Wattage	35W (Fan 17W / Lamp 18W)
Gross Weight	12.6 lbs.	Motor RPM	50-170 RPM
Maximum Airflow	4000 CFM	Maximum Noise	55 dB(A)

**U.S. Patent Nos.: 10,511,206 and 11,296,561
and 11,808,446 and 11,781,746.
Other Patent(s) Pending.**

Questions

Have questions about our products? Contact us and talk to our helpful tech support team.

Technical Support

Business Hours:

Monday – Friday (Holidays observed).

9:00 am to 5:30 pm PST.

Tel: (888) 253-2374

The product images shown in the manual are for reference purposes only.
Actual product may differ slightly.

This Carro Ceiling Fan is :



10 Speed Options



Forward Reverse
Fan Direction

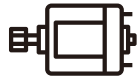

DC Motor, stable & silent,
suitable for indoor use



Built with premium materials
for durability & power



Remote Control

READ AND SAVE THESE INSTRUCTIONS

- Before you begin installing the fan, shut power off at the circuit breaker of the fuse box.
- Make sure that all electrical connections are in accordance with National Electrical Code, ANSI/NFPA 70 and local codes. Hire a licensed electrician if you are unfamiliar with installing electrical wiring.
- Make sure the installation site you choose allows the fan blades to rotate without any obstructions. Allow a minimum clearance of 2.1m (7 feet) from the floor and 18 inches from the tip of the blades to the wall.
- The outlet box and support structure must be securely mounted and capable of reliably supporting a minimum of 35 pounds. Use only U.L. listed outlet boxes marked "Acceptable for Fan Support of 15.9 kg (35 lbs) or less".
- Before and after you install the fan, make sure that all mounting components are secured to prevent the fan from falling.
- Do not insert anything into the fan blades while the fan is operating.
- To change the direction of the rotation of the blades, the fan must be in operation mode.
- All screws must be checked and retightened where necessary before installation.
- After making the wire connections, the wires should be spread apart with the grounded conductor and the equipment-grounding conductor on one side of the outlet box and the ungrounded conductor on the other side of the outlet box.
- The splices after being made should be turned upward and pushed carefully up into the outlet box. Conductor wiring identified as grounded is to be connected to a grounded conductor of power supply. Conductor wiring identified as ungrounded conductor is to be connected to an ungrounded conductor. Conductor wiring identified for equipment grounding is to be connected to an equipment- grounding conductor.
- This device complies with part 15 of the FCC Rules. Operation is subject to the following two conditions: (1) This device may not cause harmful interference, and (2) this device must accept any interference received, including interference that may cause undesired operation.

- **CAUTION:** Read all instructions and safety information before installing your new fan. Review accompanying assembly diagrams.
- **WARNING:** To reduce the risk of fire, electric shock, or personal injury, mount to a structural framing member or to an outlet box marked acceptable for fan support of 15.9 kg (35 lbs) or less. For outlet box mounting, use mounting screws provided with the outlet box.
AVERTISSEMENT: Afin de réduire les risques d'incendie, de choc électrique ou de blessures corporelles, ils doivent être montés sur des éléments de charpente structurale ou sur des boîtes de sortie marquées d'un support de ventilateur acceptable de 15,9 kg (35 LB) ou moins. Pour l'installation de la boîte de sortie, utilisez les vis de montage fournies avec la boîte de sortie”
- **CAUTION:** To reduce the risk of injury, use only the screws provided with the outlet box in conjunction with the lock washers.
- **WARNING:** To reduce the risk of personal injury, do not bend the blade bracket when installing the brackets, balancing the blades, or cleaning the fan. Do not insert foreign objects in between rotating fan blades.
- **CAUTION:** To reduce the risk of electric shock, disconnect the electrical supply circuit to the fan before installing the light kit.
- **WARNING:** To reduce the risk of fire or electric shock, this fan must be installed with a general use, non-dimmable, single gang, isolating wall control/switch.
- **WARNING:** To reduce the risk of fire or electric shock, do not use this fan with any solid-state speed control device.
AVERTISSEMENT: Ne convient pas à des régulateurs de vitesse à semi-conducteurs.
- **NOTE:** The important safeguards and instructions appearing in this manual are not meant to cover all possible conditions and situations that may occur. It must be understood that common sense, caution and care are factors which cannot be built into this product. These factors must be supplied by the person (s) installing, caring for and operating the unit.
- **CAUTION:** The light source is designed for this specific application and can overheat if serviced by untrained personnel. If any servicing is required, the product should be returned to an authorized service facility for examination or repair.
- **WARNING:** Do not use corrosive detergents for cleaning.
- **WARNING:** To reduce the risk of fire, electric shock, or injury to persons, do not use replacement parts that have not been recommended by the manufacturer. (e.g. Parts made at home using a 3D printer).
- **NOTE:** Before installing the fan, please check and inspect all of the fan components and make sure they have all been received in good condition. Contact the manufacturer if there are any missing, damaged, or broken parts.

06	Fan Diagram
08	Disassembly
09	Fan Blades
10	Light Kit
12	Mounting Options
13	Fan Bucket / Hanging
14	Safety Rope
15	Wiring
16	Securing The Fan
17	Lampshade / Power On
18	Remote Control
19	Troubleshooting
20	Care & Cleaning / FCC

Fan Diagram

CARRO

Before installing, please check to make sure you have received all the necessary components for installation. Some extra hardware may also have been included.

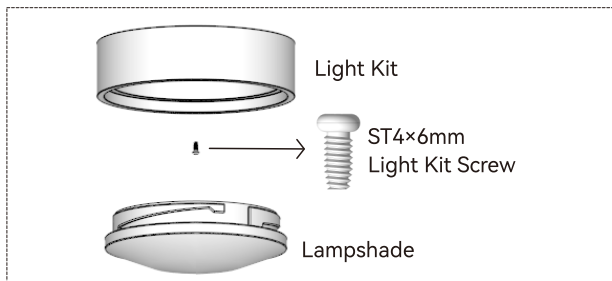
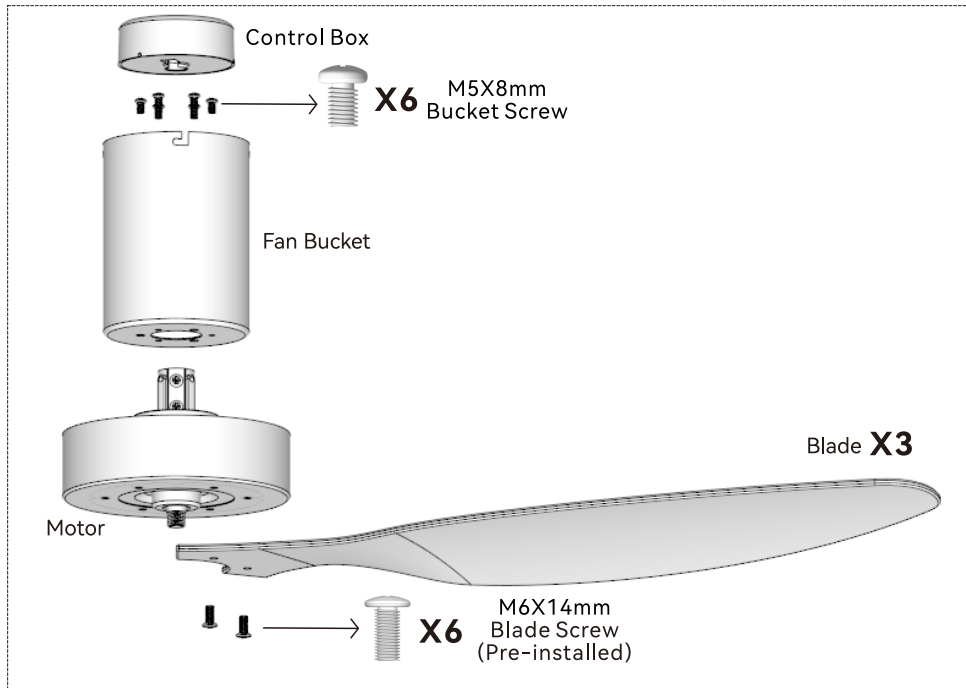
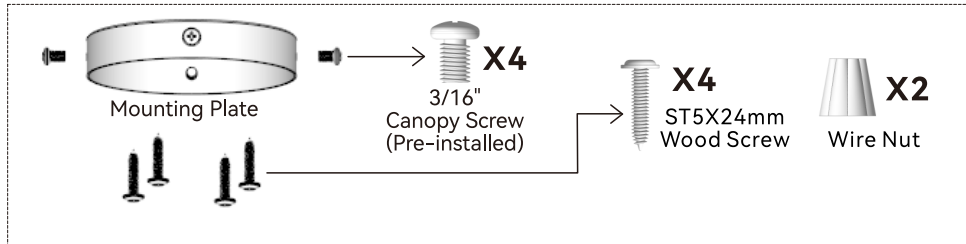

Installation

CARRO

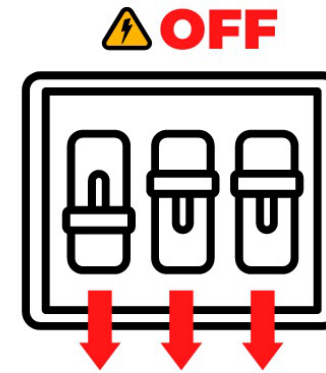

WARNING: To avoid serious injury or death, turn off the power at the circuit breaker before installing the fan.

Tools you'll need



Phillips screwdriver



Step ladder

1. Disassemble the MDF (Medium Density Fiberboard)

Remove the motor parts from the box. Use a screwdriver to loosen the three screws from the MDF and remove the MDF as shown in Fig.1.1. The MDF is used to protect the motor hub during transportation.

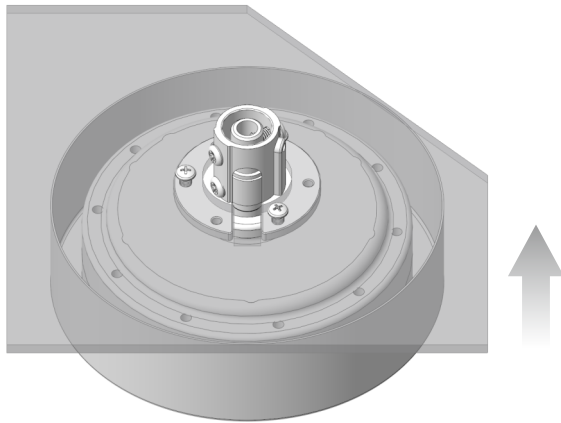

Fig. 1.1

2. Install the Fan Blades

2.1 Remove the blade screws from the motor head. Align two blade holes with the corresponding screw holes on the motor head, and secure the blades using the blade screws, as illustrated in Fig. 2.1.

2.2 Perform the same steps for the remaining blades. The completed blade installation is displayed in Fig. 2.2.

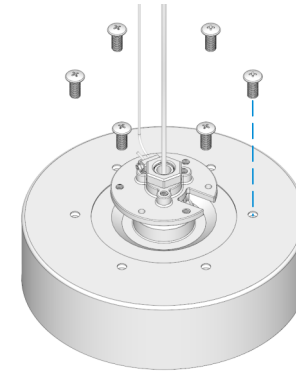

Fig. 2.1

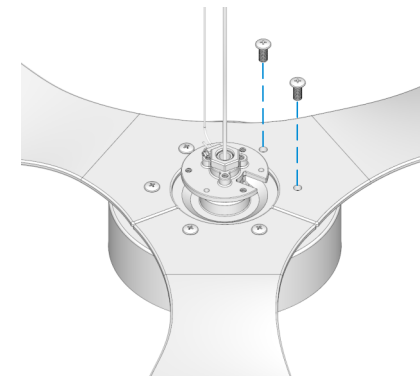

Fig. 2.2

3. Install the Light Kit

3.1 Remove the light assembly from its packaging.

3.2 Carefully place the motor hub. Pass the wire plug from the motor and the safety rope through the center hole of the light kit.

Rotate the light kit clockwise to engage the internal thread of the center hole with the external thread of the motor shaft. Following this, one of the four slots in the light kit's center hole should align with the motor shaft slot (usually marked in black), forming a screw hole for the light kit screw.

Secure the light kit screw from the hardware pack into the designated screw hole, ensuring it is tightly fastened to safely connect the motor and light kit, as illustrated in Fig. 3.1.

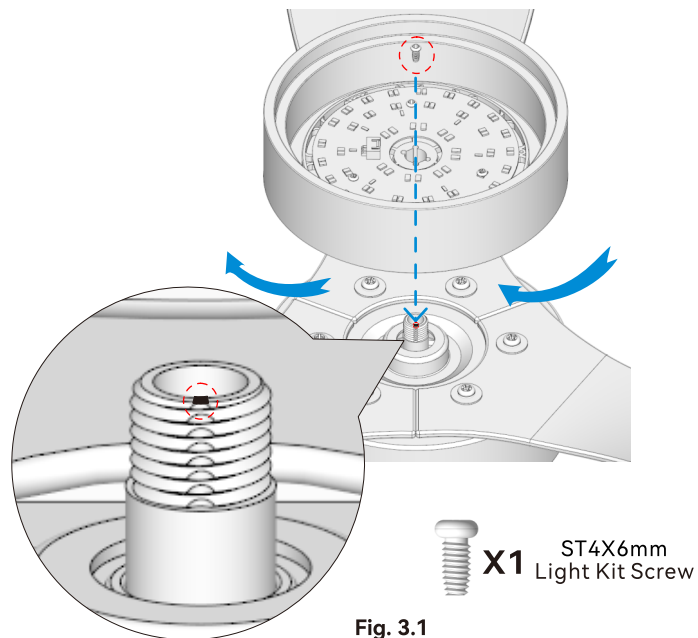

Fig. 3.1

3.3 Connect the wire plug to the light kit's terminal block as demonstrated in Fig.3.2.

Note: If you encounter difficulty passing the safety rope through the center hole of the light kit, you have the option to remove the screw on the safety rope lock. This will allow you to thread the safety rope through the center hole more easily. However, it is crucial to remember to reassemble the screw back to its original position once the light kit installation is complete. Failure to properly install the safety rope may compromise its effectiveness and increase the risk of detachment, potentially posing safety hazards.



Fig. 3.2

4. Install the Mounting Plate

4.1 Utilize a screwdriver to extract the two canopy screws situated in the single holes. Subsequently, gently loosen the other two canopy screws positioned in the L-shaped holes.

Proceed by rotating the mounting plate to align it with the designated notch, and then pull to detach the mounting plate. Remember to retain the screws for later use. Pull out the control box from the fan bucket.

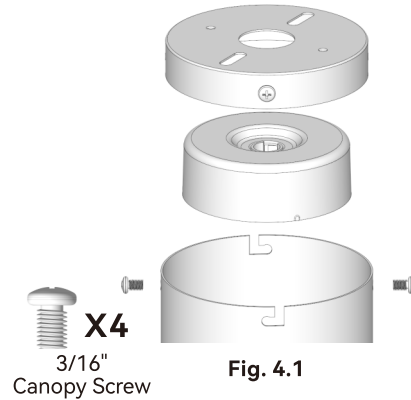

Fig. 4.1

4.2 You have two options for the mounting plate installation. Choose the one that works best for your location.

WARNING: Before beginning, make sure to turn off the power from the circuit breaker!

Note: For optimal fan performance, ensure that the mounting plate is level.

Option 1: Secure the mounting plate to a wooden ceiling beam or support structure with an approved electrical outlet box using the ST5x24mm wood screws (included) as shown in Fig. 4.2.

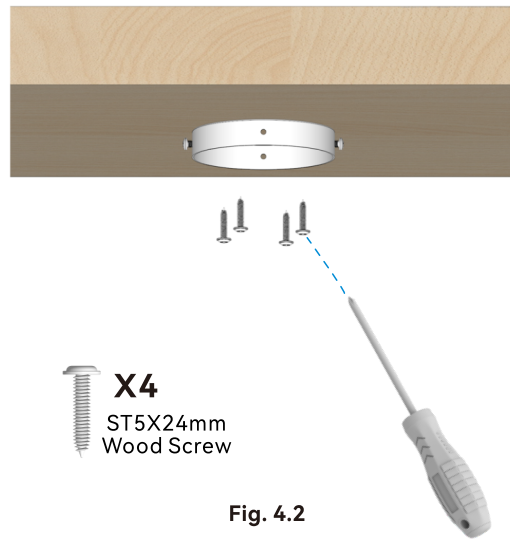

Fig. 4.2

Option 2: Use machine screws (provided with outlet box) and washers to attach the mounting plate to an existing ceiling fan-rated outlet box. If the mounting plate is installed at the outlet box, it should be installed on the outlet box with the screws that came with your outlet box. Pull the supply wires (the black, white, and ground wires) out of the outlet box and through the hole in the mounting plate, then set them aside.

WARNING: DO NOT use a plastic outlet box. Use only U.L. listed outlet boxes marked "Acceptable for Fan Support of 15.9 kg (35 lbs) or less".

5. Install the Fan Bucket

Find the 6 bucket screws in the hardware pack and use them to secure the fan bucket to the motor housing. Ensure that all screws are tightened firmly, as depicted in Fig. 5.1. Then place control box back into the fan bucket.

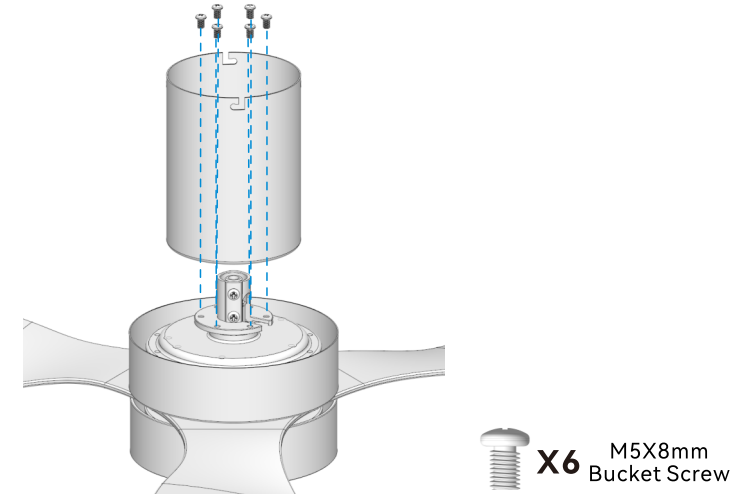

Fig.5.1

6. Hang the Fan

6.1 Carefully lift the fan-motor assembly and hang it using the hook of the mounting plate. Securely suspend the motor assembly by using one of the round holes at the outer rim of the motor housing as shown in Fig. 6.1.

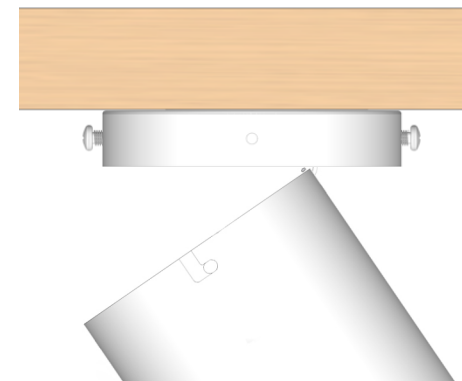

Fig. 6.1

6.2 There are multiple methods to install the safety rope; here are two options for your reference.

Option 1: Refer to Fig. 6.2. Hang the safety rope on the ceiling hook (not included). Using a screwdriver, loosen the screw on the safety rope lock. Pull the safety rope taut and then tighten the screw on the safety rope lock to ensure a firm and secure connection between the safety rope and the ceiling hook. Always double-check to ensure the safety rope is taut.

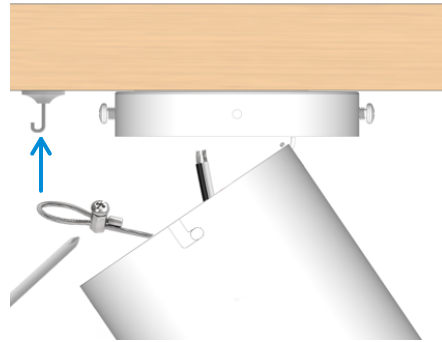

Fig. 6.2

Option 2: Refer to Fig. 6.3. Thread a screw, accompanied by a washer (both not included), through the center of the safety rope. Fasten the screw to the ceiling and then loosen the screw on the safety rope lock using a screwdriver. Pull the safety rope taut and then tighten the screw on the safety rope lock to securely anchor the safety rope to the fixed screw on the ceiling. Always double-check to ensure the safety rope is taut.

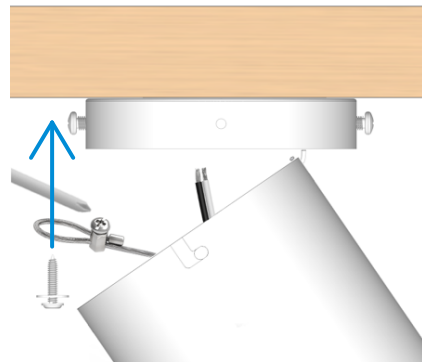

Fig. 6.3

Note: Installing the ceiling fan with a safety rope is an extra safety feature. It secures the fan to the ceiling hook or other attachment point and prevents the fan from falling even in the case of material failure.

When the safety rope is fixed and installed, it is important to adjust both the length of the wire rope and the screw on the safety rope lock to ensure a secure and tight connection with the fixed object. This step is crucial to prevent the safety rope from accidentally coming off. Improper installation of the safety rope may compromise its effectiveness and lead to potential safety risks. Therefore, it is essential to make sure the safety rope is properly tightened and secured for maximum safety.

7. Connect the Wiring

Connect the Green/Yellow wire from the mounting plate to the supply Ground wire using a wire nut.

Connect the White wire from the motor to the supply White (Neutral) wire using a wire nut. Connect the Black wire from the motor to the supply Black/Red (Hot/Live) wire using a wire nut.

Make sure all the wires are connected to the correct colors as shown in Fig. 7.1. Then, hide the wiring inside the motor housing.

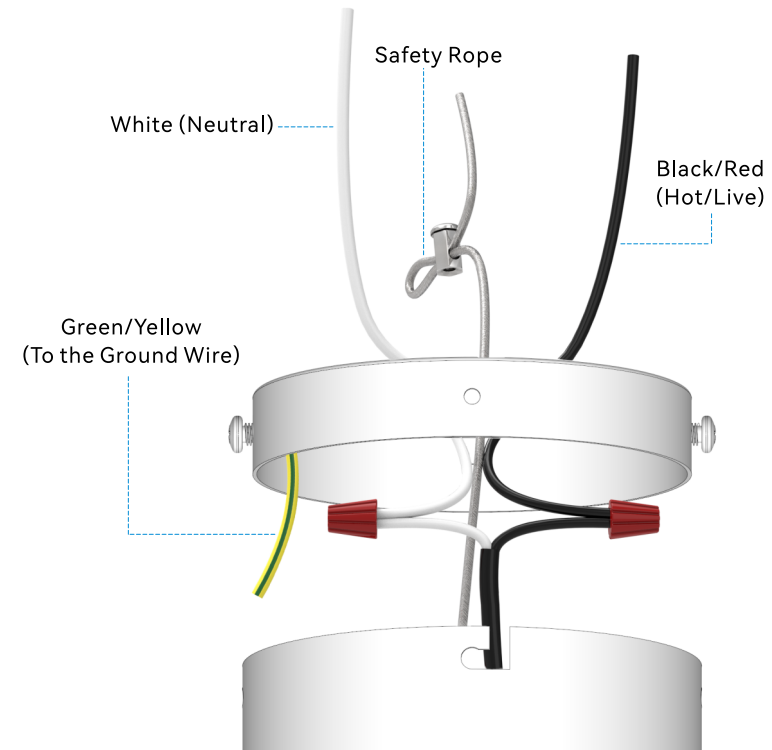

Fig. 7.1

8. Secure the Fan

With both hands, gently lift the fan body off of the hook. Ensure that the hook does not interfere with the wires.

Align the L-shaped holes on both sides of the fan body with the two loosened canopy screws on the mounting plate. Slide the two slots on both sides of the fan body between the heads of the screws, and then rotate the fan body to ensure the screws hold the fan body firmly in place.

Reinstall the other two canopy screws that were previously removed into the single holes. Tighten all four screws securely.

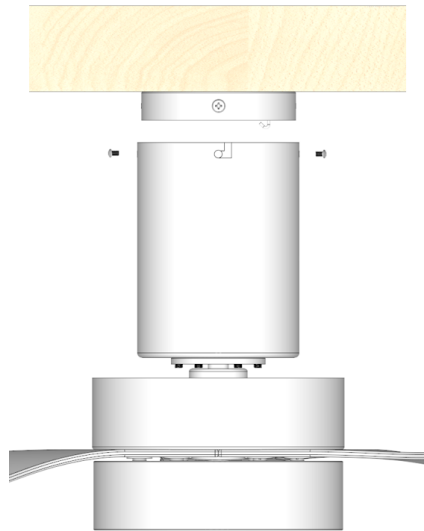

Fig. 8.1



9. Install the Lampshade

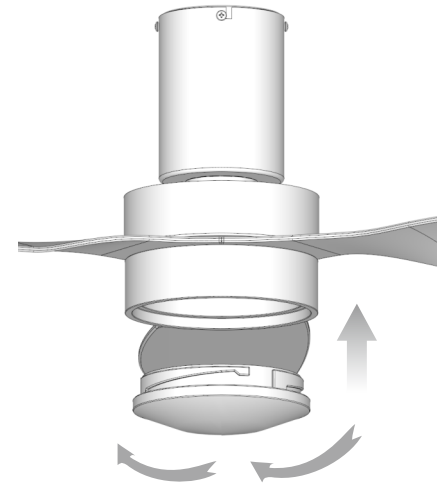

Fig. 9.1

Align the slots of the lampshade with the slots of the light kit pan, and turn the lampshade clockwise to securely lock it into place, as shown in Fig. 9.1.

Note: Do not over tighten the lampshade.



10. Power On

At this time, the ceiling fan has been installed. Turn on the power supply from the circuit breaker of the main switch or the room where the ceiling fan is installed. Once the power is on, check to see if the fan light is illuminated and pair the fan with the remote immediately.

Note: Please be aware that this ceiling fan may produce noticeable operating sounds at specific wind speeds. This is a normal operating characteristic and does not indicate any issues with its functionality.



Pair the Remote Control to Your Fan

Power on the fan and pair the remote to the fan within 1 min. To pair remote to fan, press and hold  button for 3-5 secs to pair. Successful pairing will trigger the fan light off.

Remote Control Button Definitions



Turn the fan off.



Switch between summer mode and winter mode.
 · Summer mode - (Counter-clockwise)
 · Winter mode - (Clockwise)



Turn the fan on and decrease fan speed.



Turn the fan on and increase fan speed.

Nature Toggle the fan speed between "Nature Mode" and "Breeze Mode". Simulate a soothing breeze that is gentle enough not to disrupt your sleep. To revert to the fan's regular mode, simply press either the speed-up or speed-down button.



Turn the light on or off and remote pairing.
Note: Power on the fan and pair the remote to the fan within 1 min. To pair remote to fan, press and hold  button for 3-5 secs to pair. Successful pairing will trigger the fan light off.



Switch between warm light and cool light.



Press/Hold button to decrease the light intensity.



Press/Hold to button to increase the light intensity.

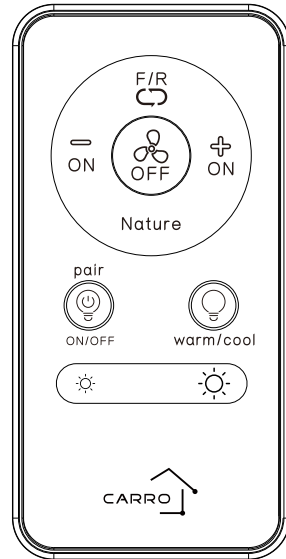

Try these troubleshooting steps before contacting Customer Service. For additional operation, maintenance, and troubleshooting information, please contact our customer service center.

SYMPTOM	POSSIBLE SOLUTION
Fan not spinning	① Make sure the fan is getting power. ② Check your circuit breaker or fuse panel and wall switch for functionality. ③ Check to make sure the fan wires are correctly connected to the house wires. ④ Remote control must be paired with the fan within 1 minute after connecting the fan to the electricity. ⑤ Use a multi-meter and test the wiring harness to see if there is any electrical output. ⑥ All the pin wiring on the circuit board must be inserted tight and in the correct position. ⑦ Remote needs to be paired with the fan first. ⑧ Make sure the fan blades spin freely. ⑨ If you're using a wall control, check the power to the breaker from your control and try working your ceiling fan manually. (Normal switch only for the fan power on/off)
Fan light not working	① Make sure LED wires are connected to the circuit board. ② Make sure the whole fan is powered.
The fan is noisy and wobbling	① Check if the blade screws are NOT rubbing against any part of the motor housing. ② Check the pin wires are NOT connected against any moving parts. ③ Check the down fan cup is NOT hitting the motor. ④ Confirm the canopy is NOT touching the ceiling while the fan is in operation. ⑤ Check the down rod is NOT slanted. ⑥ Tighten any loose screws on the light kit, fan blades, motor coupling, down rod, brackets and mounting hardware. ⑦ Confirm the hanger ball is firmly seated in the mounting bracket. ⑧ The ceiling beam must meet the minimum tensile test strength of 30kg for installation. ⑨ Make sure the blades and brackets are NOT bent or deformed. ⑩ Verify the wire connections are not rattling against each other. ⑪ Verify the fan blades are not cracked. If the fan blades are cracked, replace the damaged blades with a new blade set from the same brand as your ceiling fan to ensure compatibility. ⑫ Confirm the light kit is NOT slanting and hitting the motor.
Unable to pair remote	① Check if the wires are connected in the correct position or not. ② Check the batteries in the remote. ③ Disconnect the power for 10 minutes, reconnect the power and pair the remote with the fan immediately, within 1 minute. Also try pairing.
Fan or light turning on or off by themselves	① Confirm the circuit breaker is not malfunctioning. ② Verify the wire connections are not frayed. ③ Cut the fan power for 10 minutes then power on again. ④ All the pin wiring on the circuit board must be inserted tight and in the correct position.

WARNING: Do not expose the remote control to direct contact with water.

- 1 Check the support connections, brackets, and blade attachments twice a year. Make sure they are secure. Because of the fan's natural movement, some connections may become loose over time. It is not necessary to remove the fan from the ceiling.
2. Clean your fan periodically. Use only a soft brush or lint-free cloth to avoid scratching the finish. The plating is sealed with a lacquer to minimize discoloration or tarnishing.
3. (Optional) Apply a light coat of furniture polish to the wood blades.
4. (Optional) Cover small scratches with a light application of shoe polish.

DO NOT:

1. Use water when cleaning. Water could damage the motor, or the wood, or possibly cause an electrical shock.
2. Apply oil to your fan or motor. The motor has permanently lubricated sealed ball bearings.

WARNING: Power off the fan before performing maintenance or cleaning the fan.

FCC Statement

Note: This equipment has been tested and found to comply with the limits for a Class B digital device, pursuant to part 15 of the FCC Rules. These limits are designed to provide reasonable protection against harmful interference in a residential installation. This equipment generates, uses and can radiate radio frequency energy and, if not installed and used in accordance with the instructions, may cause harmful interference to radio communications. However, there is no guarantee that interference will not occur in a particular installation. If this equipment does cause harmful interference to radio or television reception, which can be determined by turning the equipment off and on, the user is encouraged to try to correct the interference by one or more of the following measures:

- Reorient or relocate the receiving antenna.
- Increase the separation between the equipment and receiver.
- Connect the equipment into an outlet on a circuit different from that to which the receiver is connected.
- Consult the dealer or an experienced radio/TV technician for help.

WARNING: Changes or modifications to this unit not expressly approved by the party responsible for compliance could void the user's authority to operate the equipment.