

ASSEMBLY INSTRUCTIONS



CAUTION

◆ Inspect the wire insulation for any cuts, abrasions, or exposed copper that may have resulted during shipping. If there is a defect in the wire, do not attempt installation.

◆ Before starting installation of this fixture or removal of a previous fixture, disconnect the power by turning off the circuit breaker or by removing the fuse at the fuse box.

TOOLS REQUIRED



Ladder



Safety glasses



Electrical tape



Phillips screwdriver



Flat blade screwdriver



Pliers

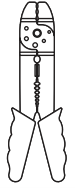

Wire strippers

HARDWARE INCLUDED

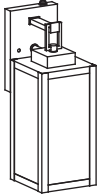

Fixture

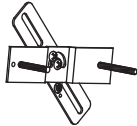

Mounting Unit



Ball Nuts



Rubber Rings



Mounting Screws



Wire Nuts

***PARTS SHOWN MAY DIFFER SLIGHTLY PER LIGHT FIXTURE**

EXPLODED PARTS

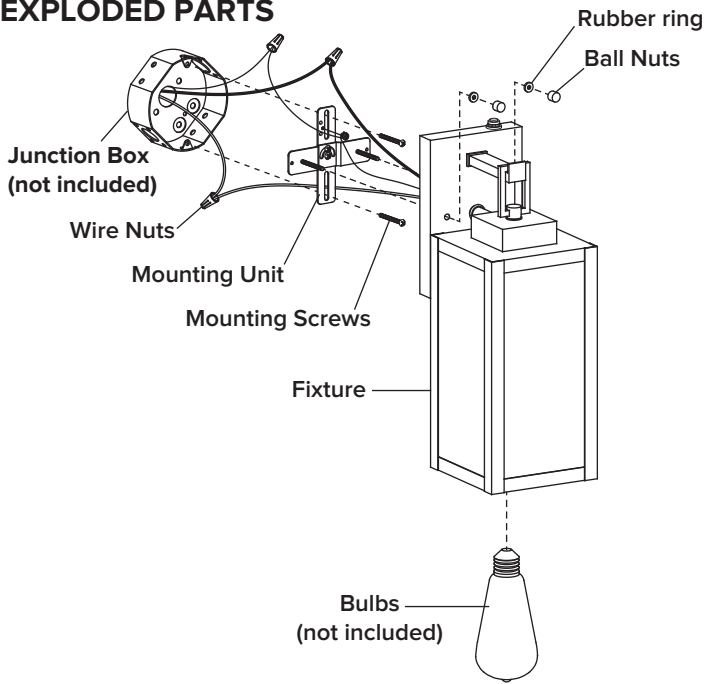

INSTALLATION

STEP 1

Unscrew the **rubber rings** and **ball nuts** from the **mounting unit**. Use the **mounting screws** to attach the **mounting unit** to the junction box (not included).

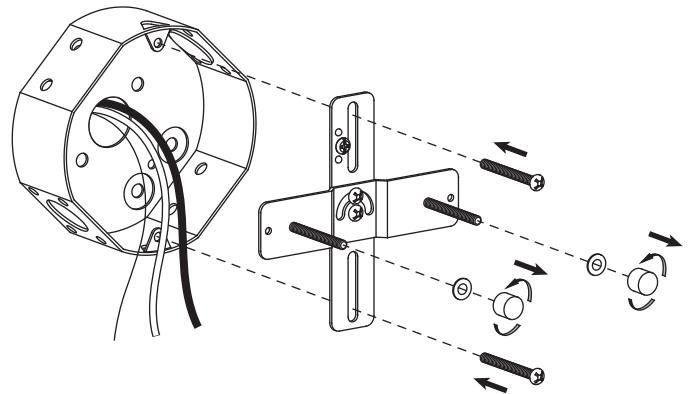

STEP 2

Make the electrical connection from the junction box (not included) to the **fixture**. Connect the ground wire to the **mounting unit** using the preinstalled green ground screw. Next, connect the live wire, neutral wire and ground wires with the supplied **wire nuts**. Secure with electrical tape.

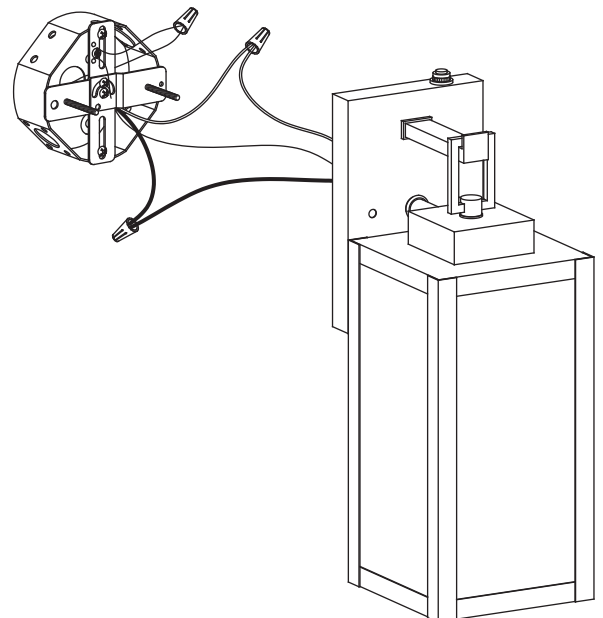

Black or Red wire
(live wire)
from the junction box

White wire
(neutral wire)
from the junction box

Bare or Green ground wire
from the junction box

Black wire from
the fixture

White wire from
the fixture

Ground wire from
the Fixture

*Green Ground Screw



*Sealing tape
(not included)

ASSEMBLY INSTRUCTIONS (INSTALLATION)

STEP 3

Attach the **fixture** to the **mounting unit** through screw holes as shown, and secure it with **rubber rings** and **ball nuts**.

NOTICE: Please use caulk in the back plate and wall mounting surface to prevent water from entering.

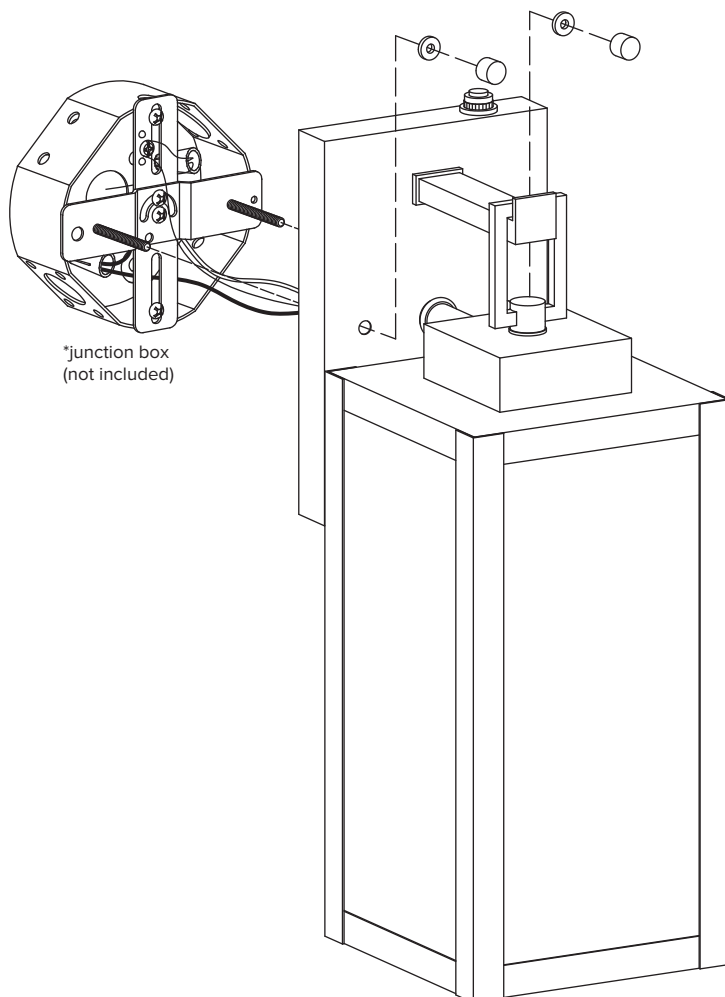

STEP 4

Install bulb (not included)

