

ASSEMBLY INSTRUCTION



SECRETARY DESK

ASSEMBLY INSTRUCTIONS

ASSEMBLY TIPS:

1. Remove hardware from box and sort by size.
2. Please check to see that all hardware and parts are present prior to start of assembly.
3. Please follow attached instructions in the same sequence as numbered to assure fast & easy assembly.



Warning!

1. Don't attempt to repair or modify parts that are broken or defective. Please contact the store immediately.
2. This product is for home use only and not intended for commercial establishments.



ASSEMBLY TIME

10 MINUTES

PARTS IDENTIFICATION

A PRINCIPAL PART



1PC

C BOTTOM PANEL



1PC

B LONG LEG



4PCS

D SHORT LEG



4PCS

HARDWARE IDENTIFICATION

1 BOLT
5/16"×2"



1PC

3 FLAT WASHER
5/16×19×2mm



4PCS

2 LOCK WASHER
5/16×12×2mm



4PCS

4 ALLEN WRENCH
5mm



4PCS

NOTE :

PHILLIPS HEAD SCREW DRIVER IS REQUIRED IN THE ASSEMBLY PROCESS;HOWEVER, MANUFACTURER DOES NOT PROVIDE THIS ITEM.

ASSEMBLY INSTRUCTIONS

STEP 1

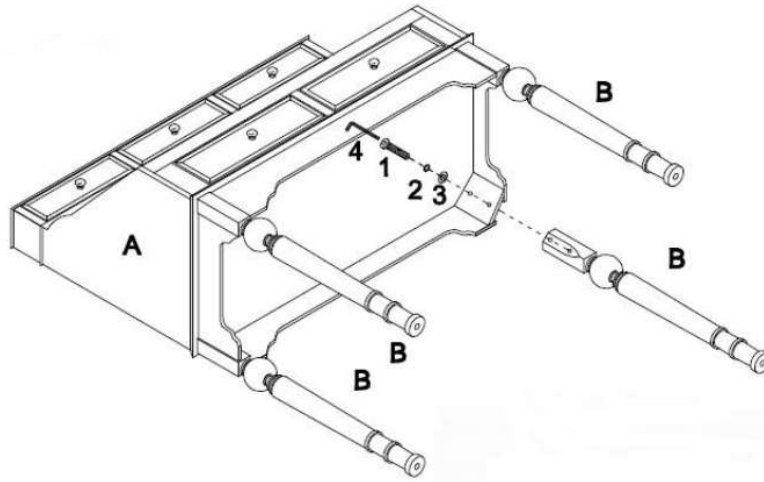

STEP 2

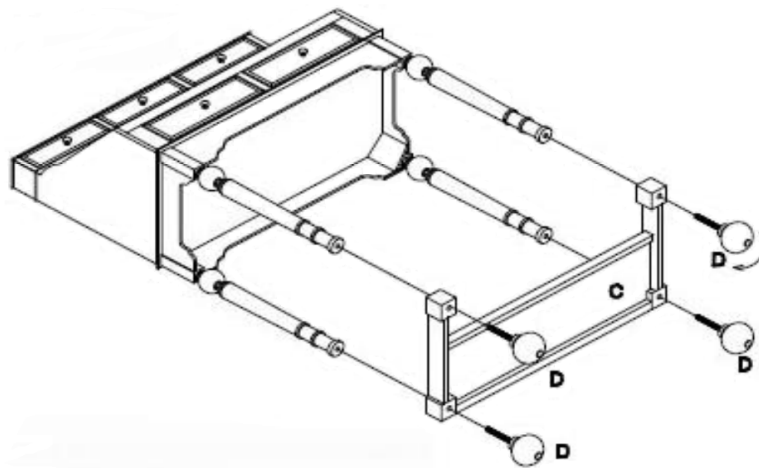

STEP 3



NOTE :

PHILLIPS HEAD SCREW DRIVER IS REQUIRED IN THE ASSEMBLY PROCESS;HOWEVER, MANUFACTURER DOES NOT PROVIDE THIS ITEM.

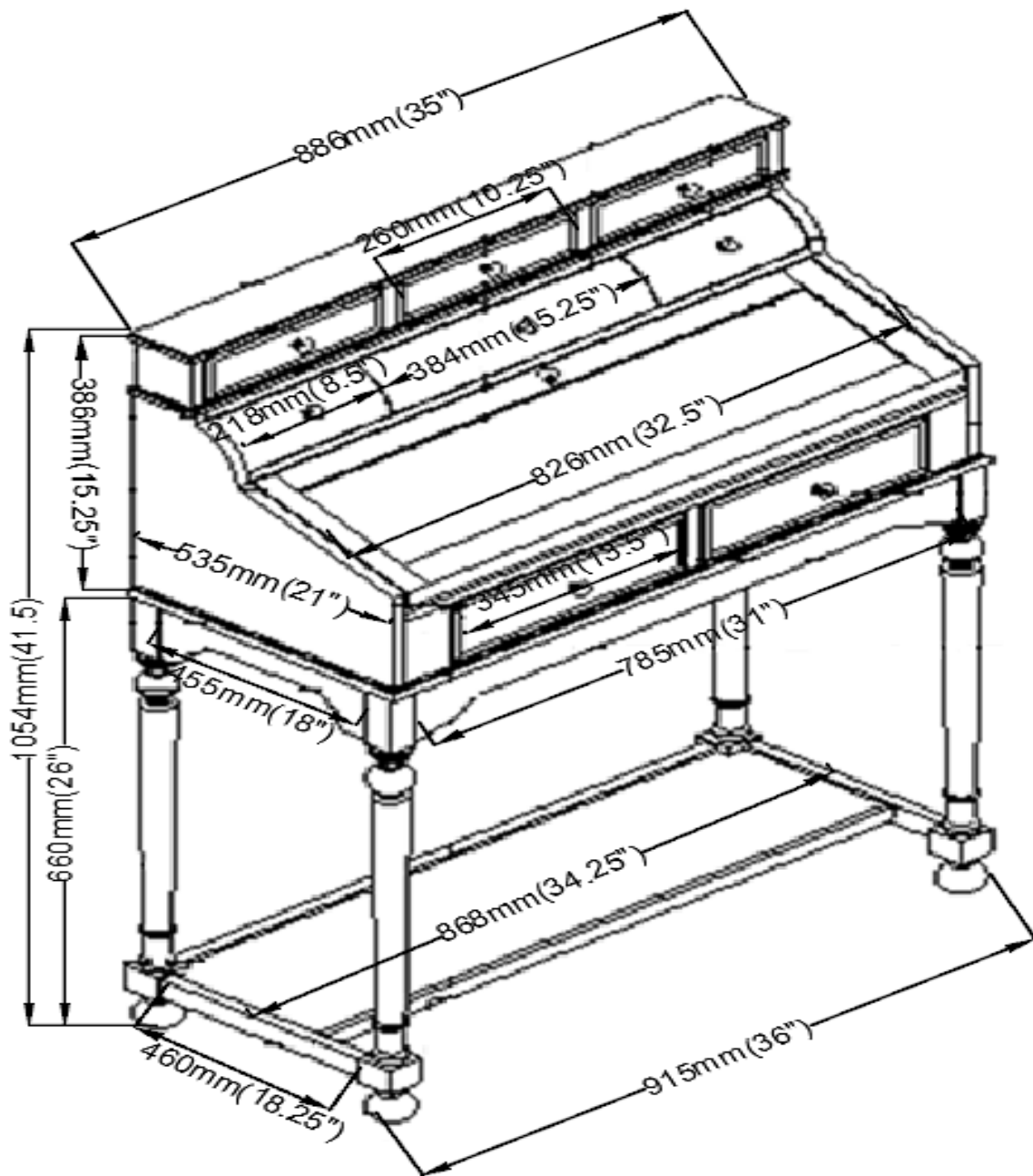

NOTE:

Dimension tolerance $\pm 5\%$