

KING BED ASSEMBLY INSTRUCTIONS

PARTS AND HARDWARE PACKING CONFIGURATIONS

BOX #1

A. HEADBOARD: 1PC B. LEGS : 2PCS C. STRETCHER : 1 PC

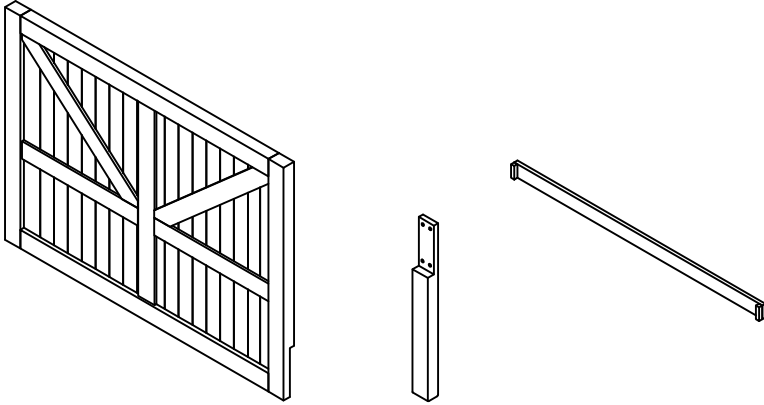

BOX #2

D. FOOTBOARD: 1PC

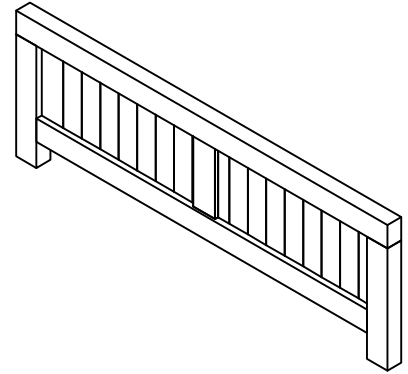

BOX #3

E. SIDE RAILS: 2PCS

F. SLATS: 5PCS

G. CENTER LEG 10 PCS

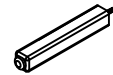
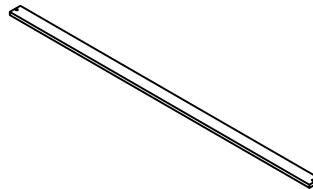
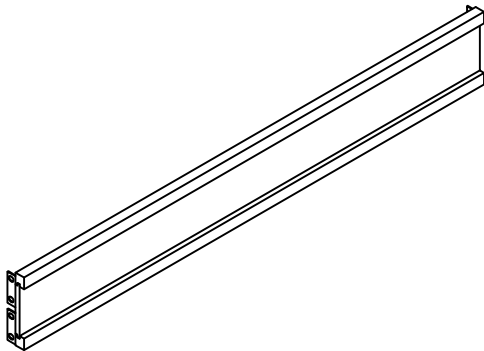

BED ASSEMBLED

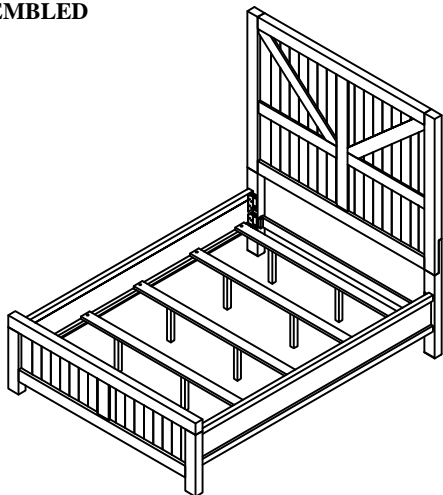

HARDWARE PACKED IN BOX #3

1. ALLEN BOLT
M8x50MM: 10PCS



2. ALLEN BOLT
M8x30MM: 16PCS



3. SPRING WASHERS
M8xØ12x1.7: 26PCS



4. FLAT WASHERS
M8xØ19x1.7: 26PCS



5. SCREW
M4x30MM: 10 PCS



6. ALLEN KEY
M4 x 110: 1PC



KING BED ASSEMBLY INSTRUCTIONS

STEP 1

ATTACH THE LEGS (B) TO THE HEADBOARD (A) USING FOUR M8X50 ALLEN BOLTS (1), SPRING WASHERS (3) AND FLAT WASHERS (4) PER LEG. DO NOT TIGHTEN COMPLETELY. ATTACH THE STRETCHER (C) TO THE LEGS WITH ONE M8X50 ALLEN BOLTS, SPRING AND FLAT WASHERS PER SIDE. TIGHTEN ALL TEN BOLTS WITH ALLEN KEY (6).

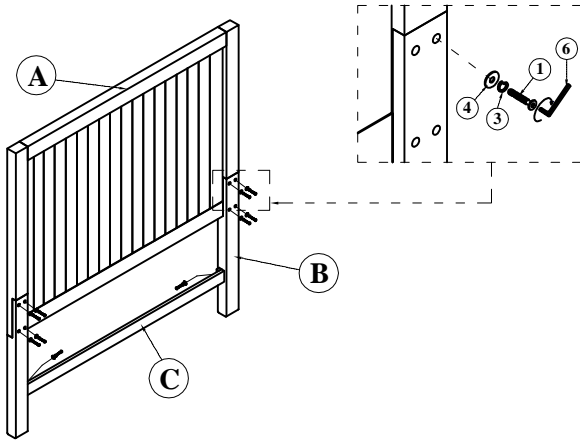

NO.	PICTURE	SIZE	QTY.
①		M8x50	10
③		M8xØ12xt1.7	10
④		M8xØ19xt1.7	10

STEP 2

ATTACH THE SIDE RAILS (3) TO THE HEADBOARD AND FOOTBOARD (D). USE FOUR M8X30 ALLEN BOLTS, SPRING WASHERS AND FLAT WASHERS PER END; 8 BOLTS PER RAIL. DO NOT TIGHTEN COMPLETELY. REPEAT FOR SECOND RAIL THEN TIGHTEN ALL SIXTEEN BOLTS COMPLETELY.

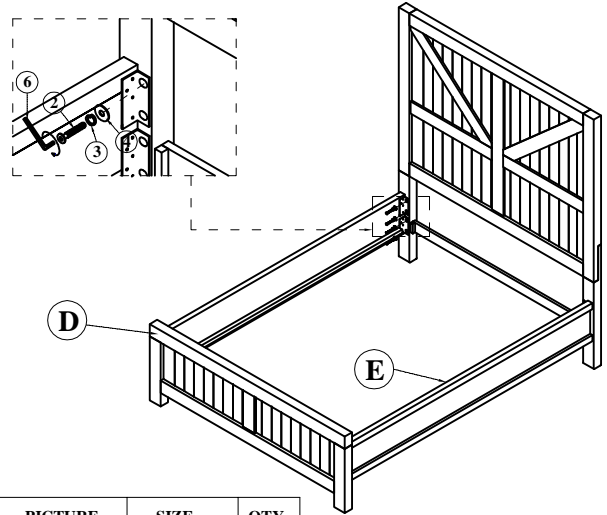

NO.	PICTURE	SIZE	QTY.
②		M8x30	16
③		M8xØ12xt1.7	16
④		M8xØ19xt1.7	16

STEP 3

ATTACH THE CENTER LEG SUPPORTS (G) TO THE SLATS (F). FOLLOWING THE ILLUSTRATION, ATTACH THE SLATS TO THE BED USING WOOD SCREWS (5). NOTE THAT THE SCREW DRIVER IS NOT INCLUDED.

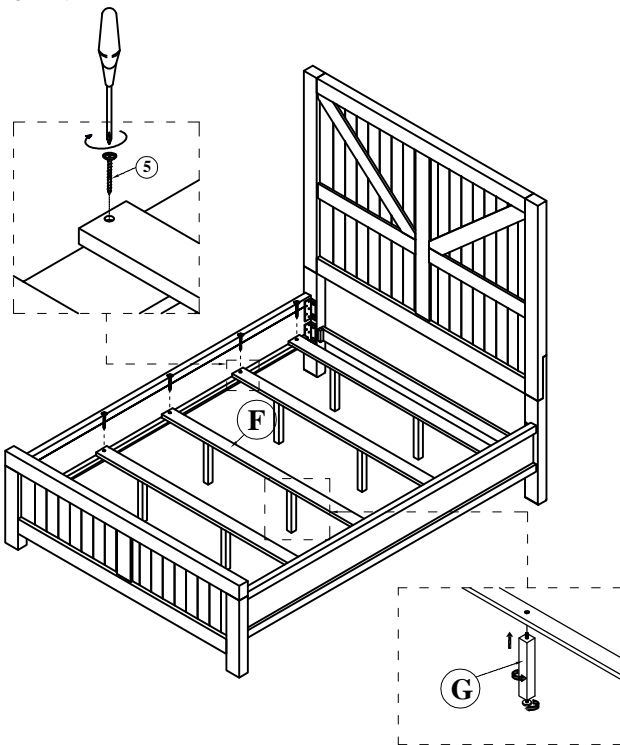

NO.	PICTURE	SIZE	QTY.
⑤		M4x30	10

STEP 4

ASSEMBLY COMPLETED

