

# ASSEMBLY INSTRUCTION:

## 1.Initial Tightening

Use a hex key (Allen wrench), not a power drill, to tighten each screw to about 50% before fully securing any of them. Fully tightening one screw too early may cause others to misalign.

## 2.Final Tightening

Once all parts are aligned, gradually and evenly tighten all screws using the proper tools.









## 3.Misalignment Fix







If some screws don't line up, loosen all screws to 50%, adjust the parts, and try again.

## 4.Stability Issue

If the item feels unstable, loosen all screws, adjust it on a flat surface, then retighten them evenly.

# Hardware Fittings

Item No.	Reference Image	Description	Qty.	Extra Spare Parts Qty.
A		screw M6*20	8	1
B		washer for M6	16	1
C		spring washer for M6	8	1
D		nut for M6	8	1
E		Screw cap	8	1
F		allen key for M6	1	0
G		Spanner for M6	1	0
H		Adjustable foot pads	4	1

Item No.	Reference Image	Description	Qty.	Extra Spare Parts Qty.
I		screw M8*30	4	1
J		washer for M8	4	1
K		spring washer for M8	4	1
L		nut for M8	4	1
M		Screw cap	4	1
N		allen key for M8	1	0
O		Spanner for M8	1	0
P				

## Step1

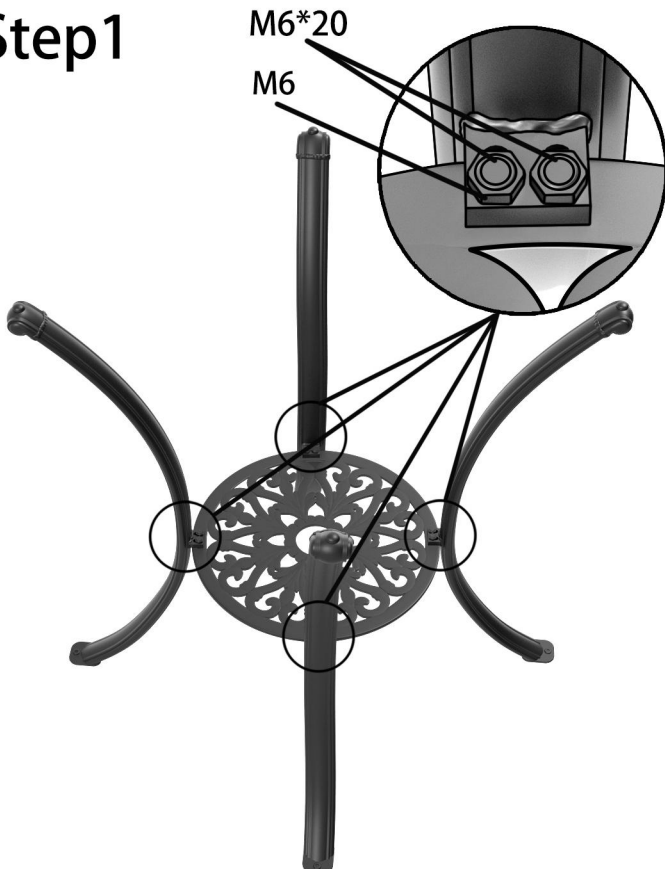

## Step2

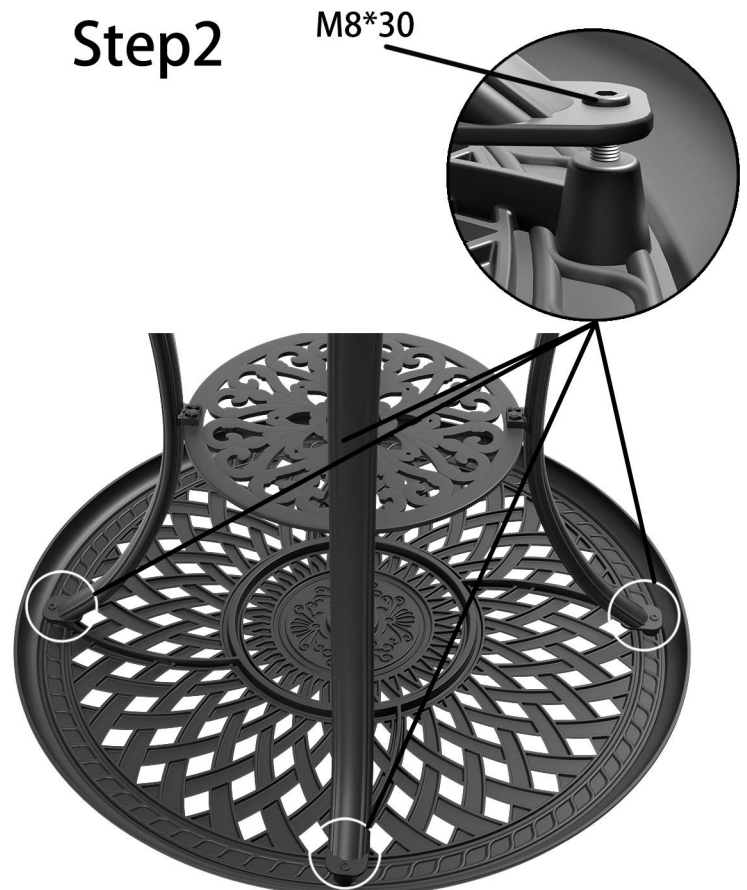

# ASSEMBLY INSTRUCTION:

## 1.Initial Tightening

Use a hex key (Allen wrench), not a power drill, to tighten each screw to about 50% before fully securing any of them. Fully tightening one screw too early may cause others to misalign.

## 2.Final Tightening

Once all parts are aligned, gradually and evenly tighten all screws using the proper tools.







## 3.Misalignment Fix



If some screws don't line up, loosen all screws to 50%, adjust the parts, and try again.

## 4.Stability Issue

If the item feels unstable, loosen all screws, adjust it on a flat surface, then retighten them evenly.

# Hardware Fittings

Item No.	Reference Image	Description	Qty.	Extra Spare Parts Qty.
A		screw M8*20	6	1
B		screw M6*15	4	1
C		spring washer for M6	4	1
D		spring washer for M8	6	1
E		washer for M6	4	1
F		washer for M8	6	1
G		Screw cap	10	1

Item No.	Reference Image	Description	Qty.	Extra Spare Parts Qty.
H		allen key for M8	1	0
I		allen key for M6	1	0
J				
K				
L				
M				
N				

## Step1

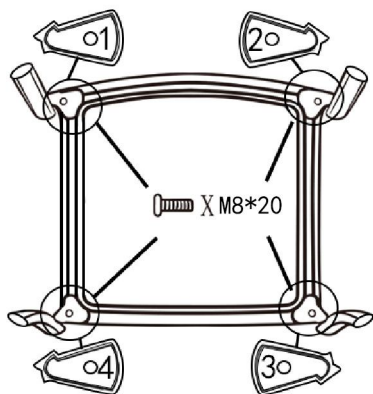

## Step2

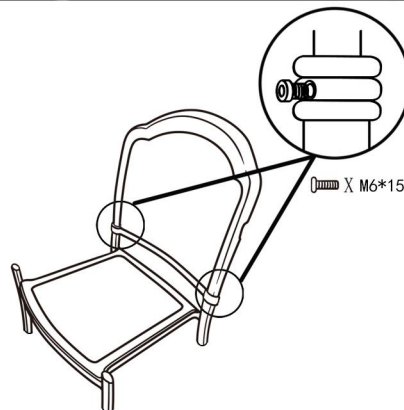

## Step3

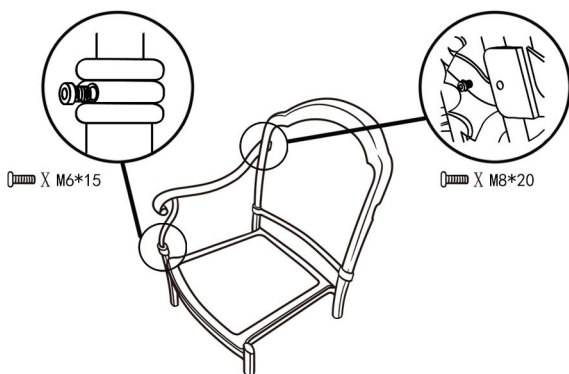

## Step4

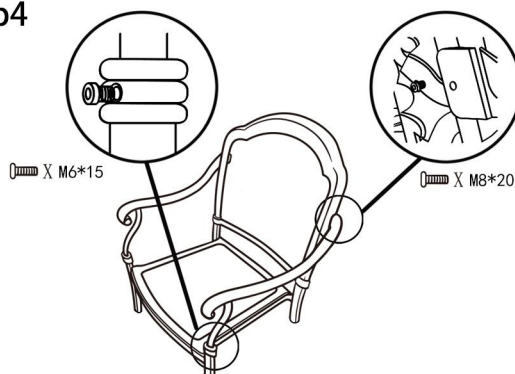

## Part List



A.  
Bracket  
1 pc.



B.  
Connector  
1 pc.

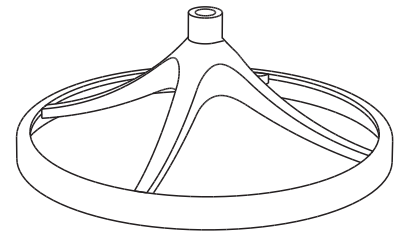

C.  
Base  
1 pc.

## Hardware List

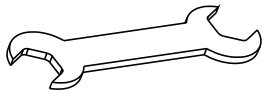

Spanner  
1 pc

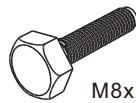

M8x20  
Bolt  
4 pcs



Flat Washer  
4 pcs



Spring Washer  
8 pcs



Flat Washer  
2 pcs



M8x35  
Bolt  
4 pcs

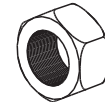

Nut  
4 pcs

## Assembly Instructions 1/2

### IMPORTANT

- Use a soft cloth between these parts and the floor.
- Do not use power tools above 8 volts to assemble.
- Do not tighten all the bolts until each part is properly assembled.
- The unit must be level to work properly. Use the included adjustable levelers to level.
- Keep Wrench as the bolts may need to be tightened in the future.

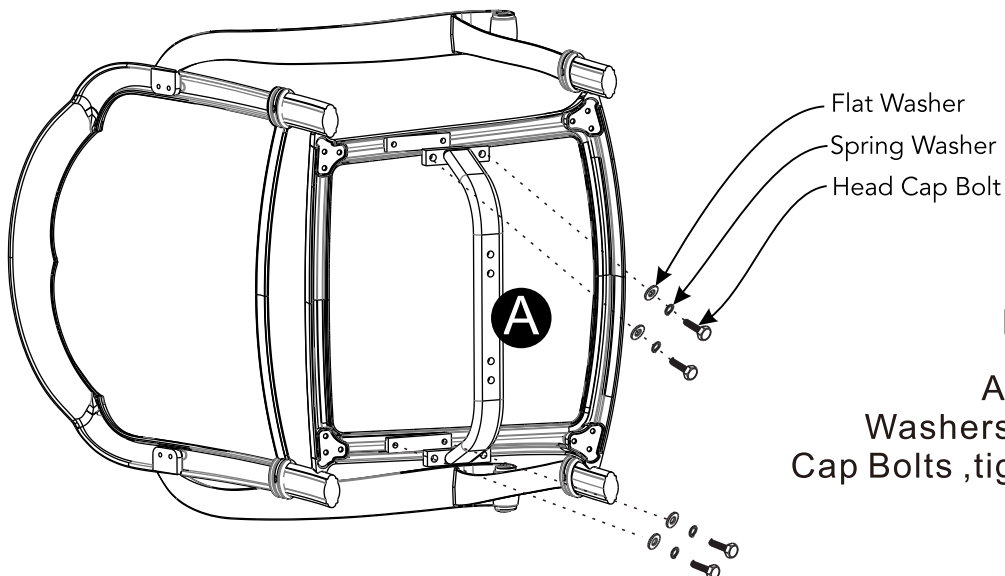

### STEP 1

Place frame on a soft cloth.

Attach unit to Frame with Flat Washers , Spring Washers and Head Cap Bolts ,tightening bolts only halfway .

Tighten all Bolts .

**STEP 2**

Attach unit to Connector (B) with Bolts, Flat Washers, Spring Washers and Nuts, tightening bolts and nuts only halfway. (See Figure 1)

Tighten all Bolts and Nuts.

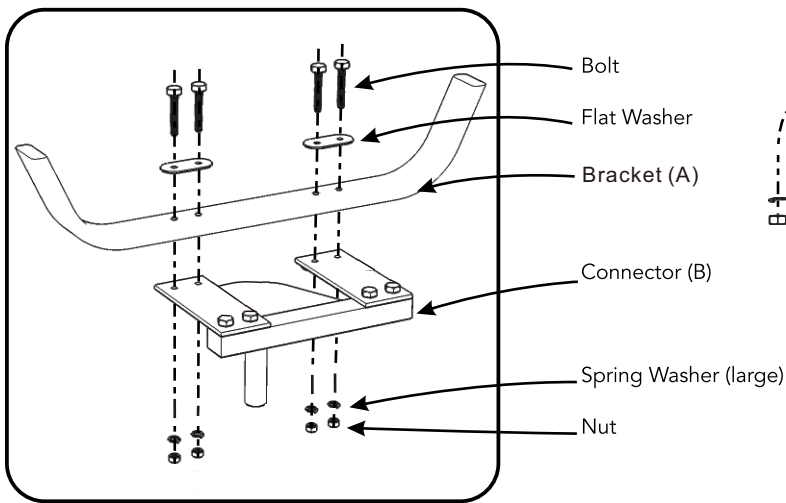
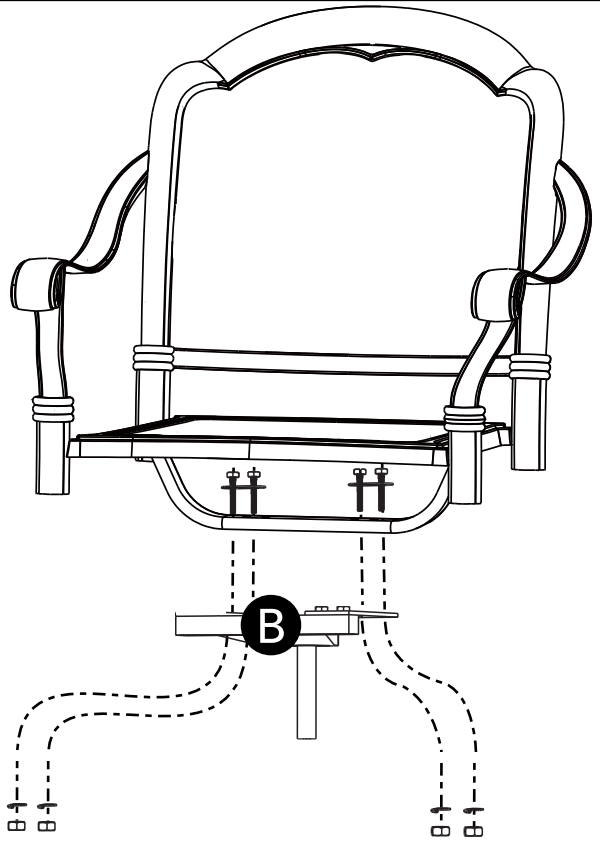
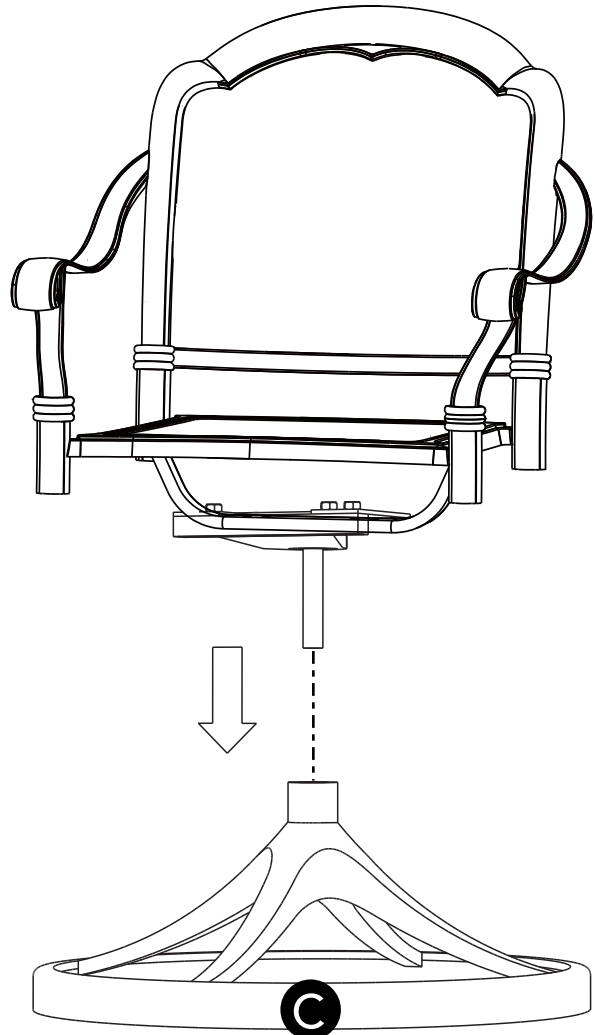

Figure 1



**STEP 3**

Place unit onto Base (C).