

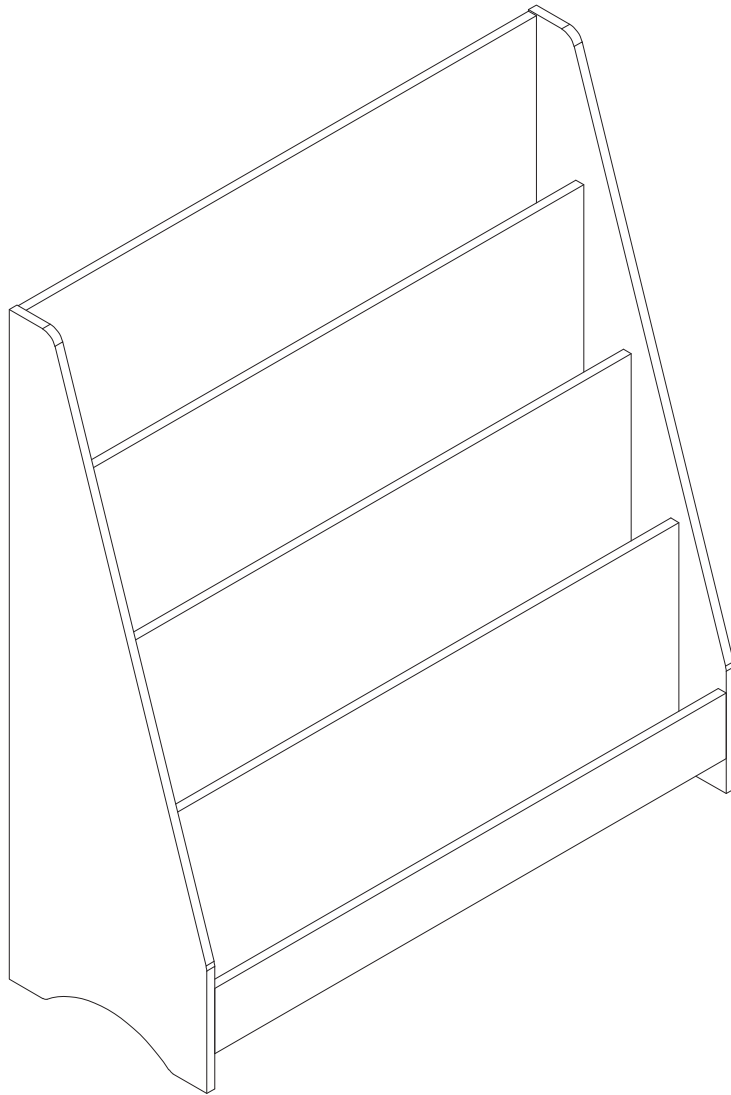

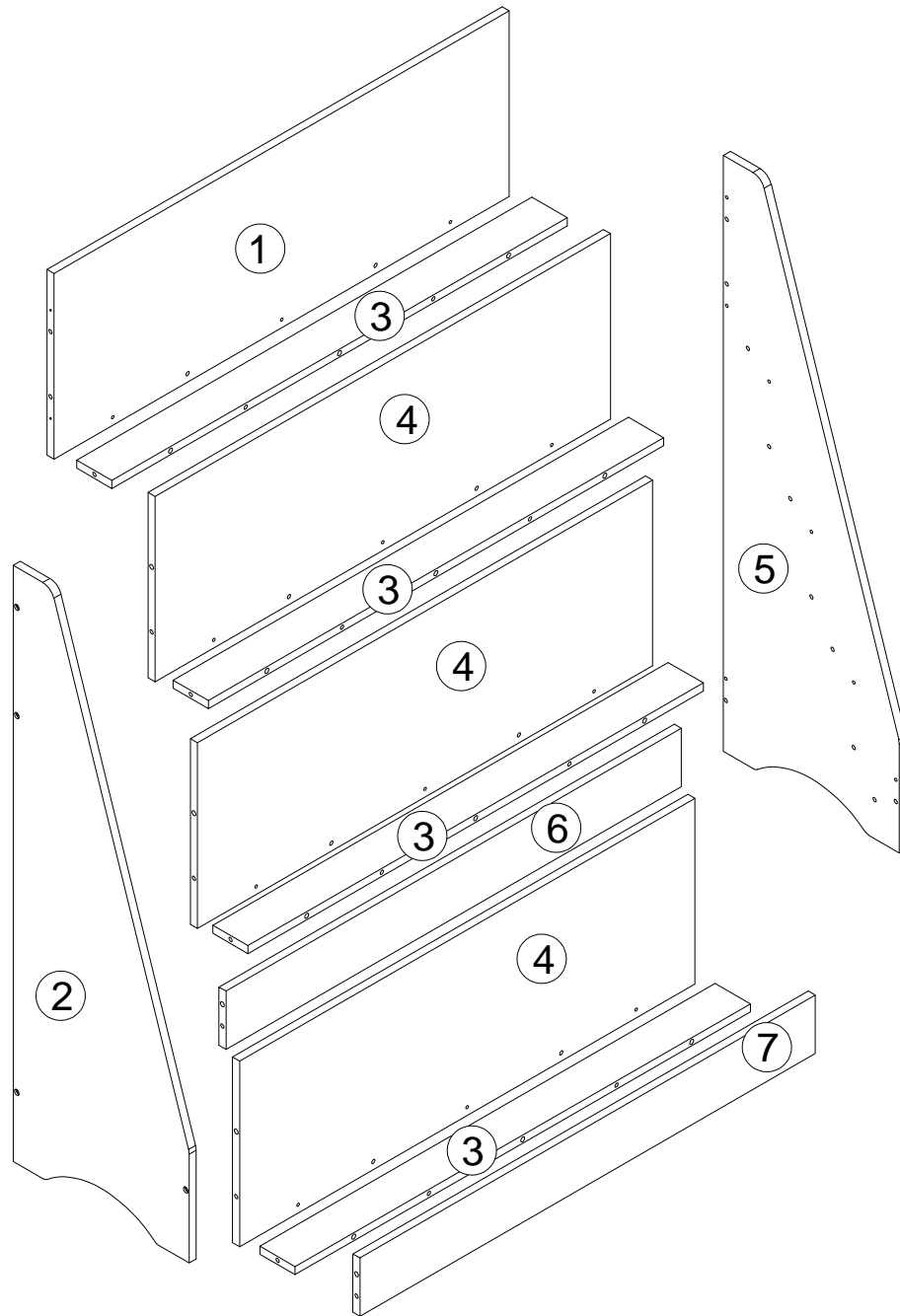

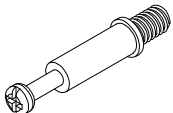

# ASSEMBLY INSTRUCTION



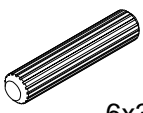
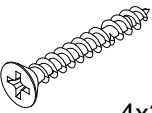
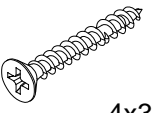
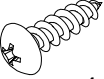

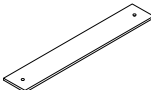

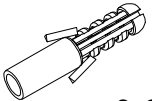
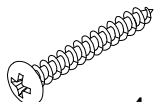

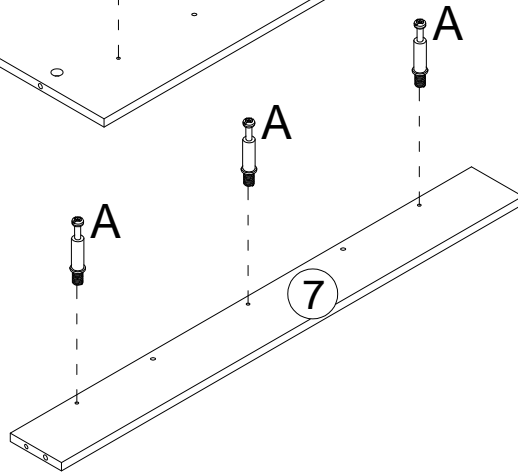
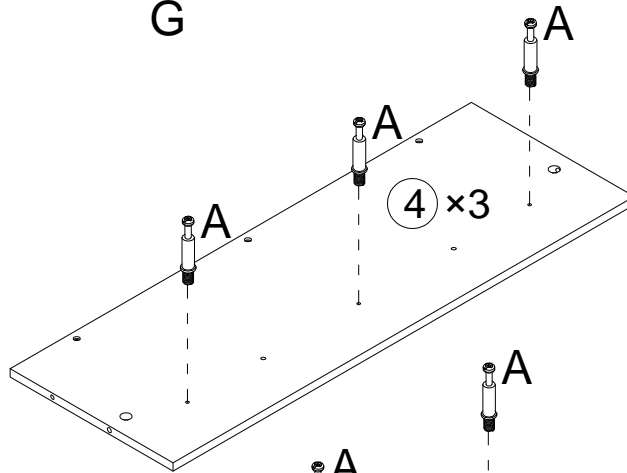
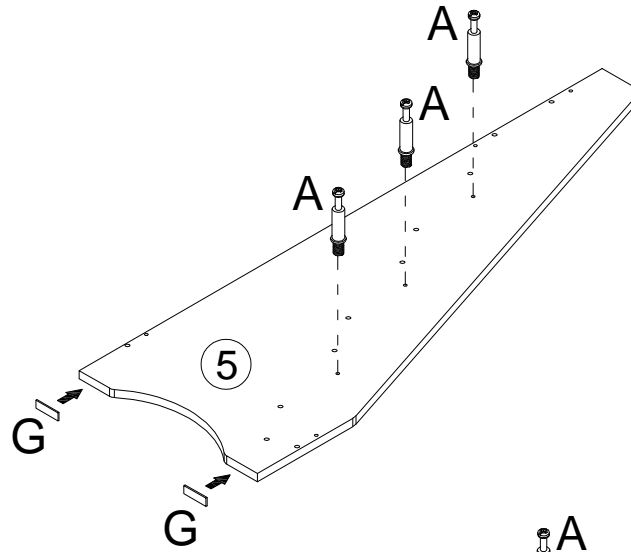
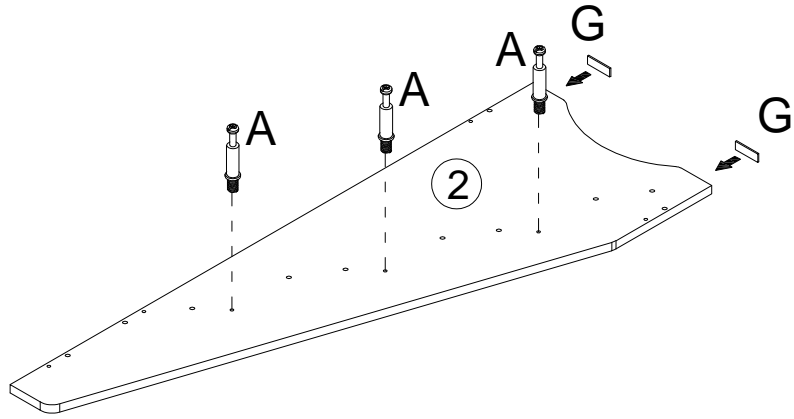
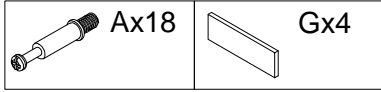
A	x 18	B	x 18	C	x 38	D	x 8	E	x 12
				 6x30mm		 4x35mm		 4x30mm	
F	x 1	G	X 4	H	X 1	I	X 8	J	X 1
 4x12mm								 6x30mm	
K	x 1								
 4x35mm									

# STEP 1



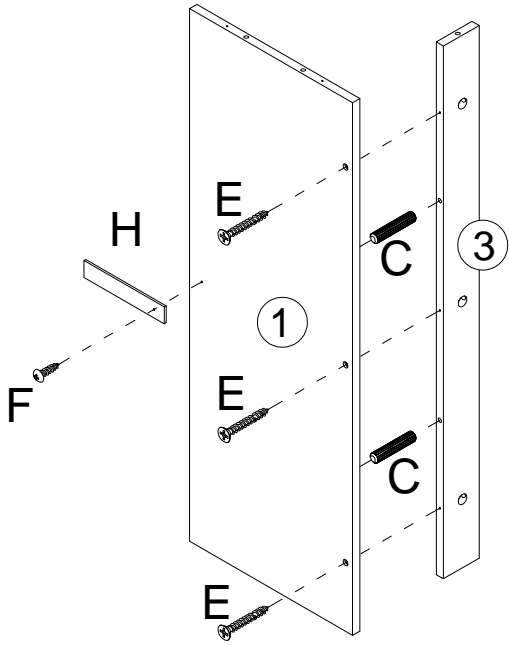

# STEP 2

 Cx2 6x30mm	 Ex3 4x30mm	 Fx1 4x12mm	 Hx1
--	---	---	---



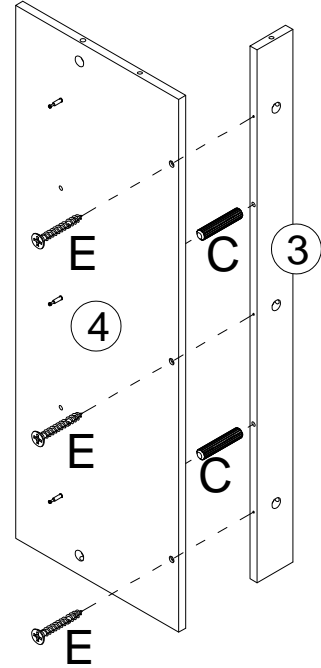

# STEP 3

 Cx6 6x30mm	 Ex9 4x30mm
---	---



# STEP 4

 Bx6	 Cx4 6x30mm
---	---

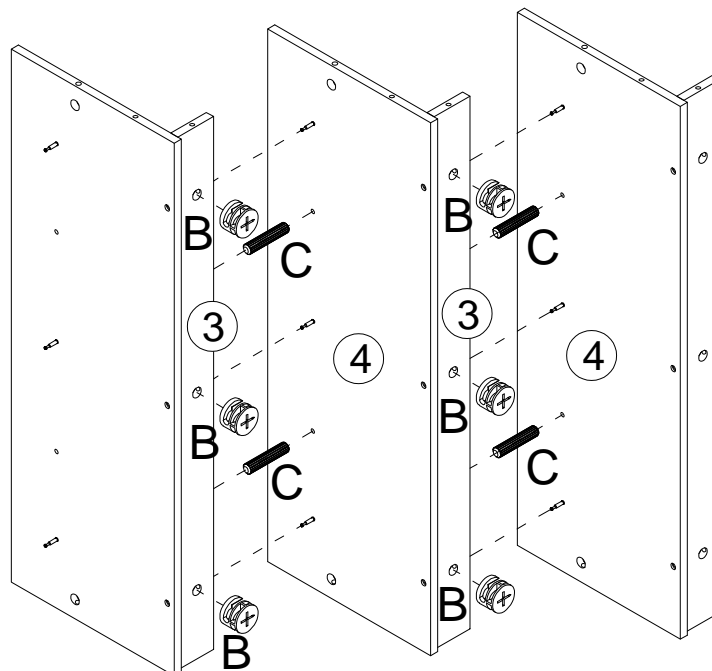

# STEP 5

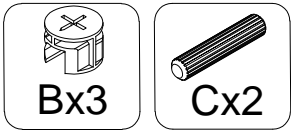
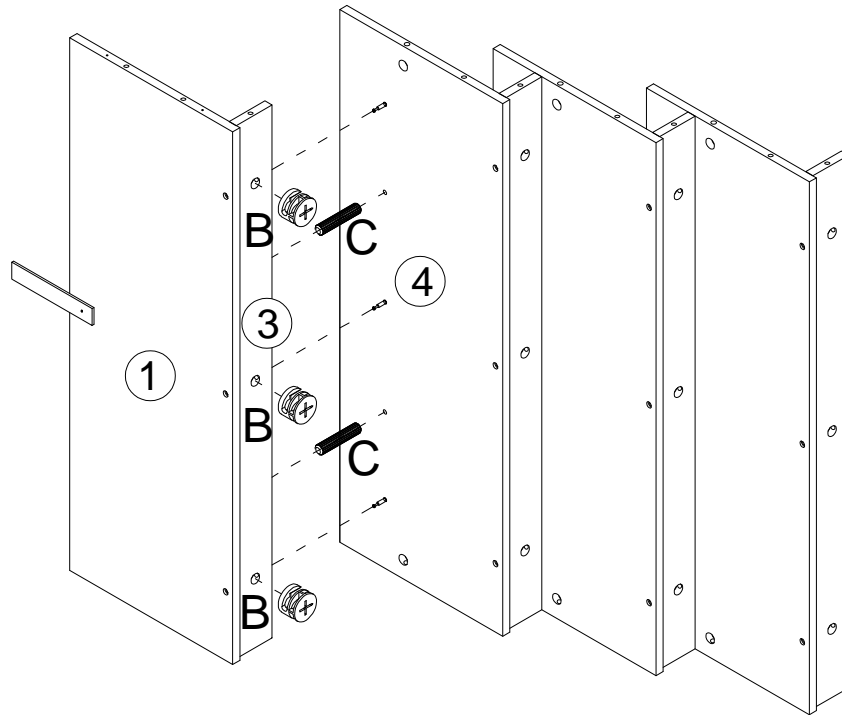
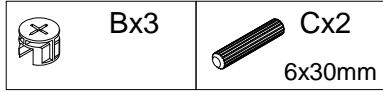

# STEP 6

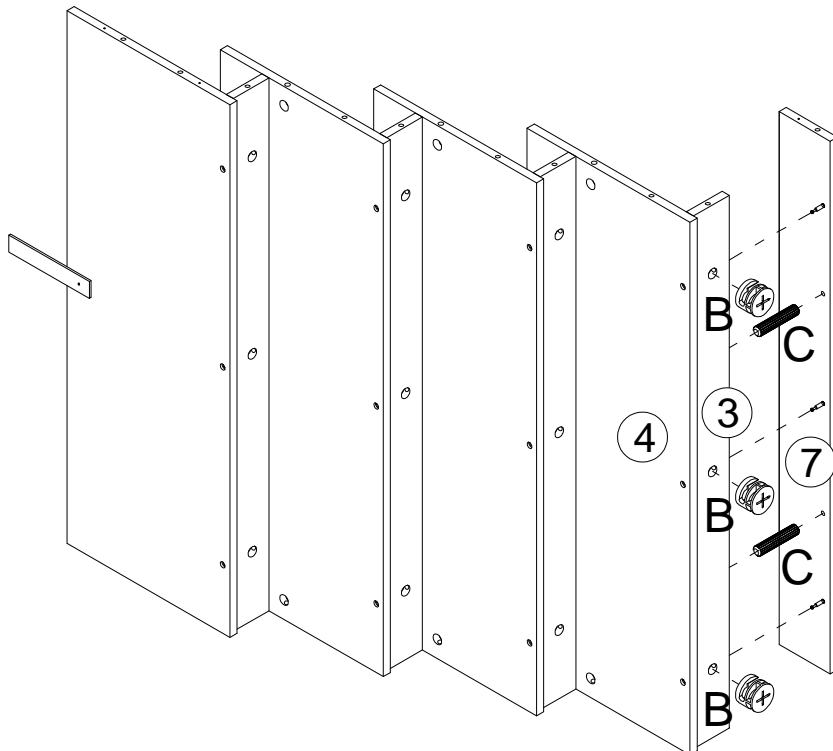
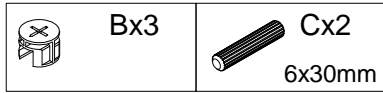

# STEP 7



Bx3



Cx10  
6x30mm

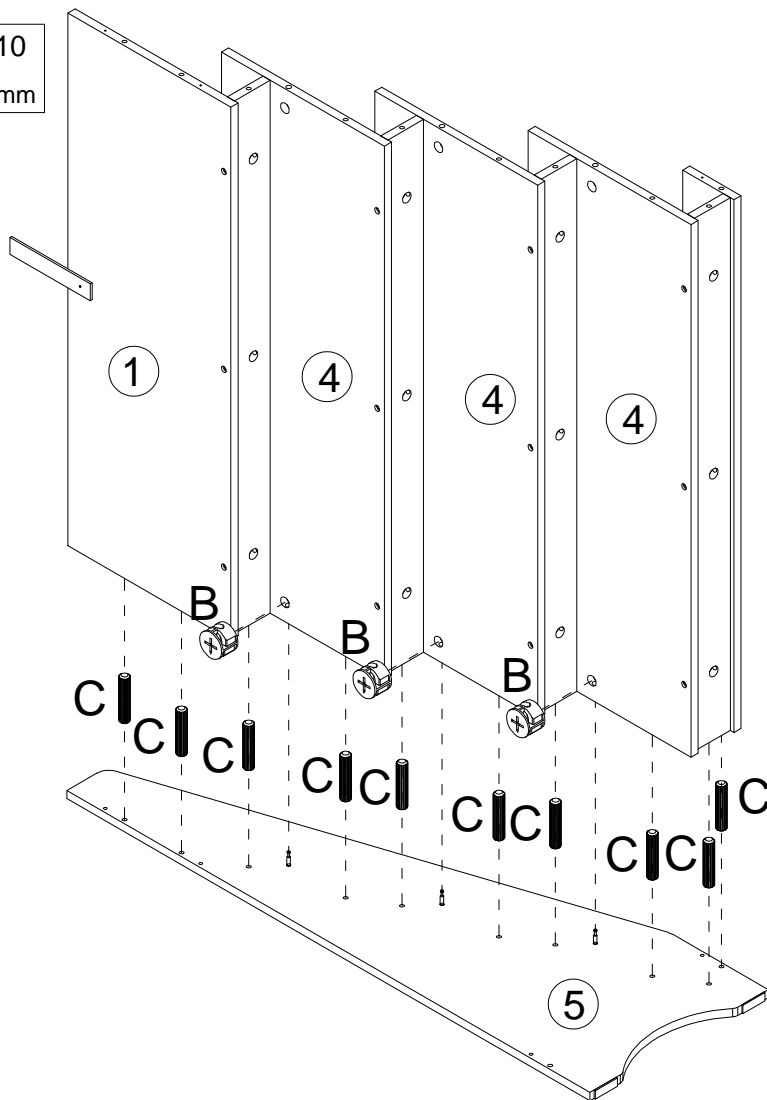

# STEP 8



Cx1  
6x30mm

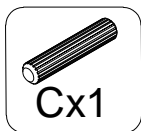
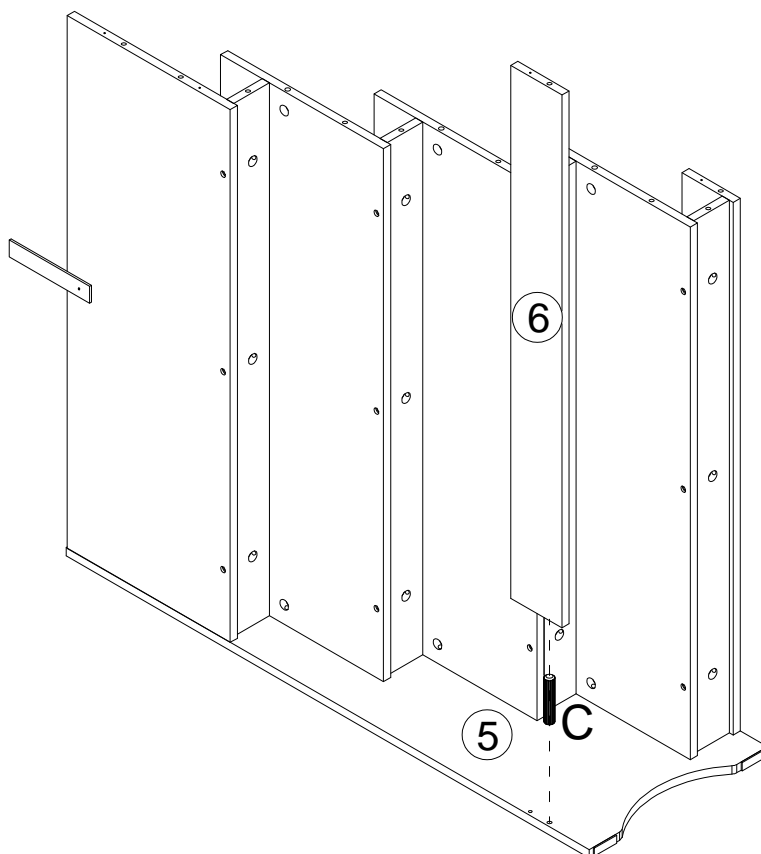

Cx1

# STEP 9



Bx3





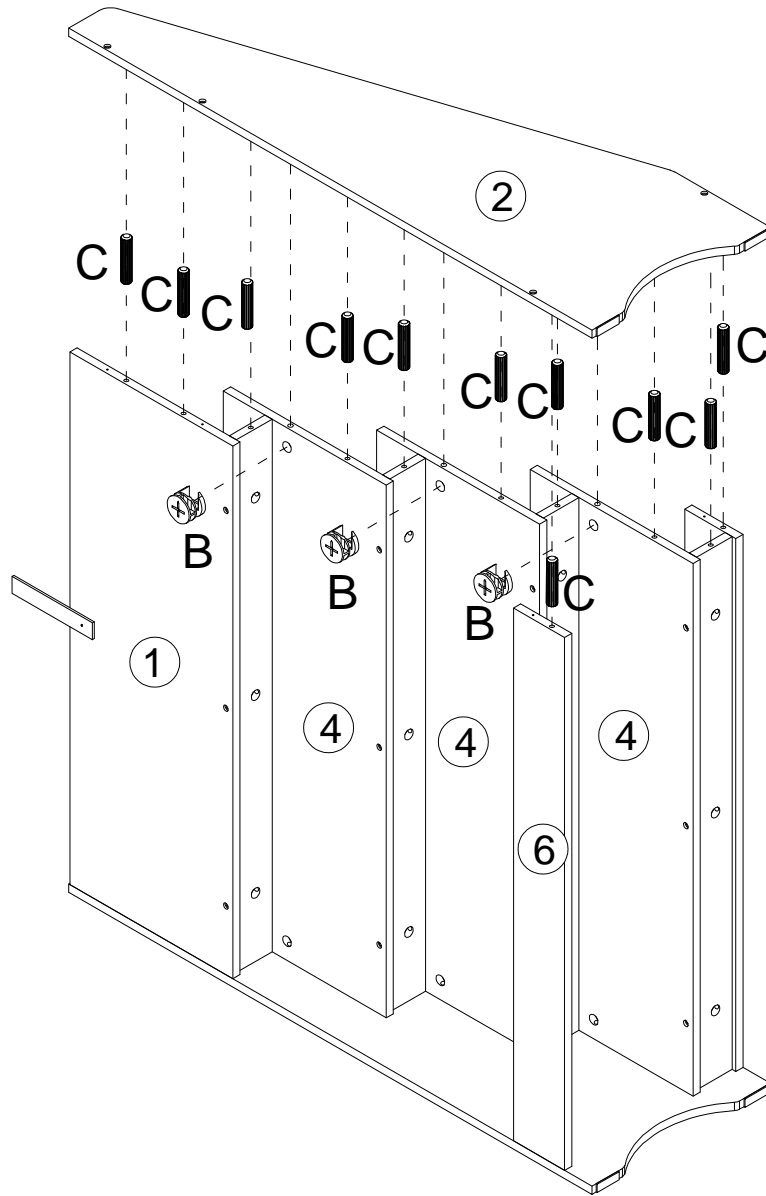

Cx11

6x30mm



# STEP 10

 Dx8 4x35mm	 Ix8	 Jx1 6x30mm	 Kx1 4x35mm
---	---	---	---

