

HARDWARE IDENTIFICATION:

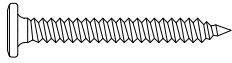

A x 08
(Ø1/4"x2-3/8")



B x 06
(Ø1/4" x 1-1/4")



C x 06
(Ø1/4")



D x 06
(Ø1/4")



E x 08
(Wood plug)



F x 04
(Shelf pin)

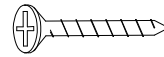

G x 04
(Ø4 x 1")



(Allen Key)

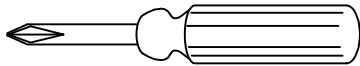

Screwdriver (not provided)

IMPORTANT:

1. Do not tighten bolts completely until all bolts are completely lined up and inserted into holes / nuts.
2. Do not over tighten screws and bolts to avoid stripping.
3. Please use hand tools to assemble this product. Do not use power tools.

PART IDENTIFICATION:

PARTS	DESCRIPTION	QTY
#1	TOP PANEL	01
#2	RIGHT SIDE PANEL	01
#3	LEFT SIDE PANEL	01
#4	BACK PANEL	01
#5	RIGHT DIVIDER PANEL	01
#6	LEFT DIVIDER PANEL	01
#7	BOTTOM RAIL	01
#8	TOP RAIL	01
#9	MIDDLE BOTTOM PANEL	01
#10	SIDE BOTTOM PANEL	02
#11	SLIDING DOOR	02
#12	SHELF	01
#13	CUSHION	01

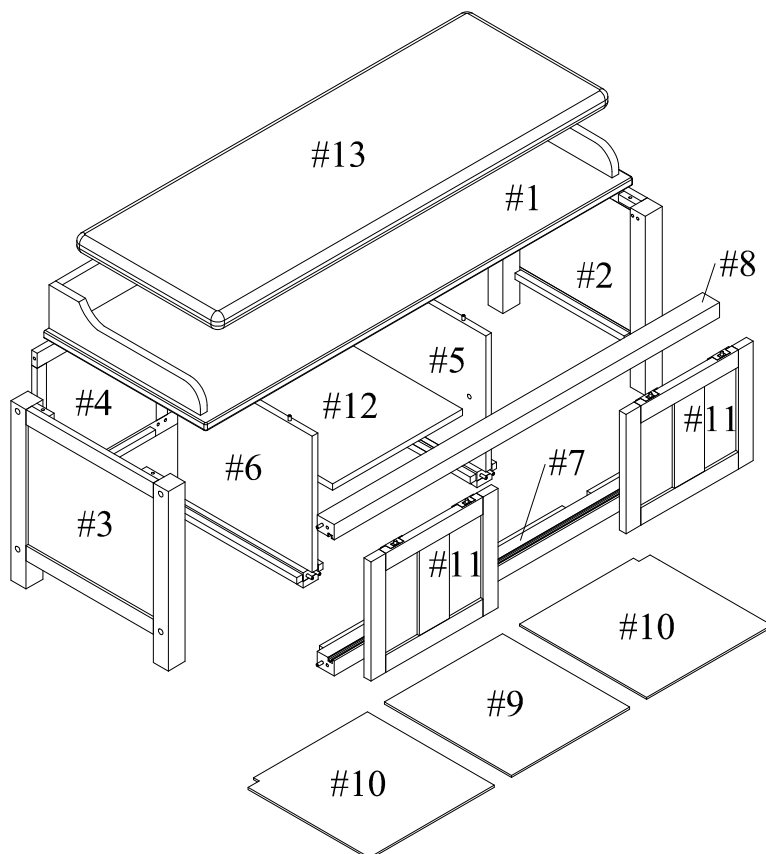

1.

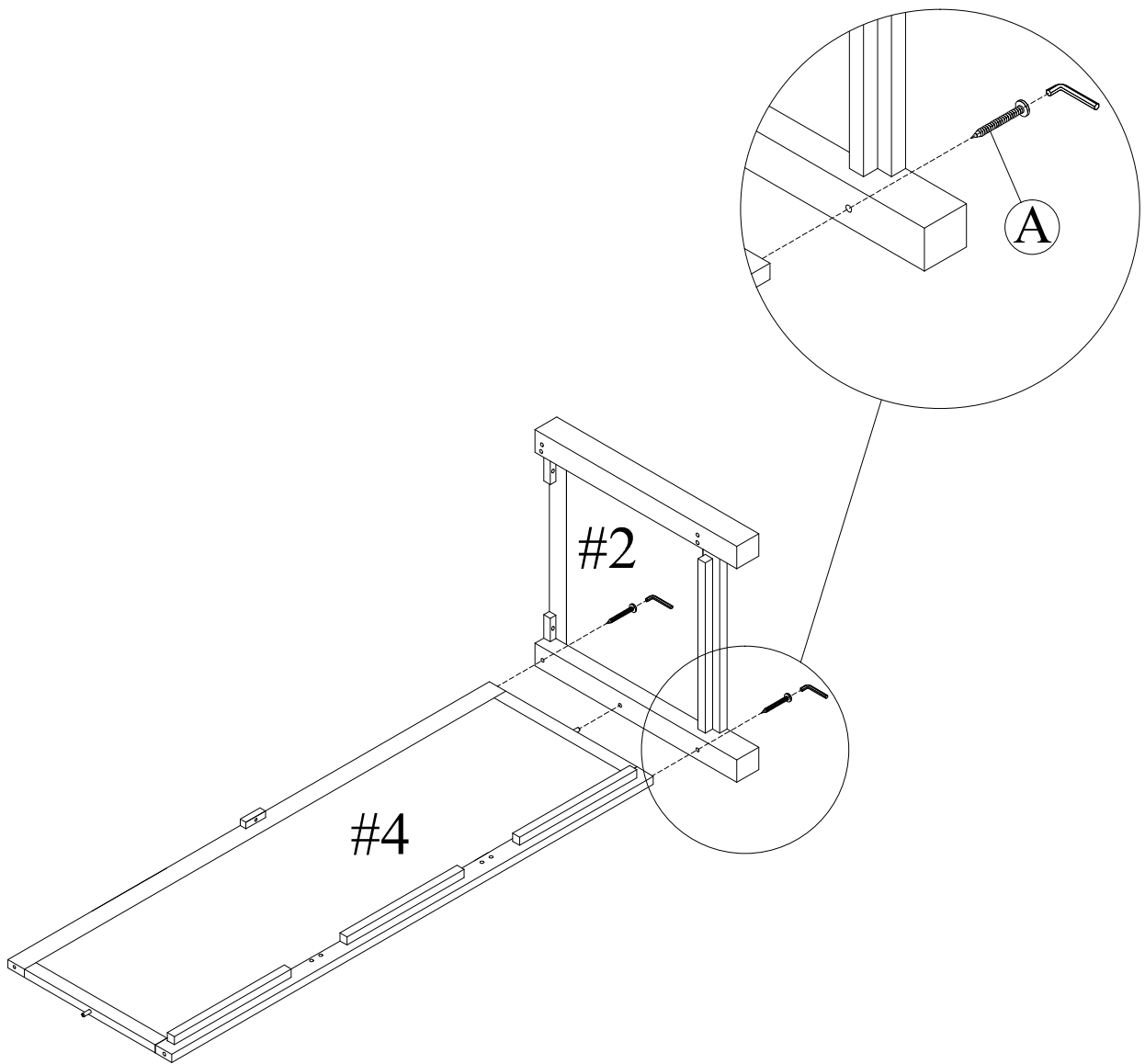

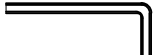

A		02
		01

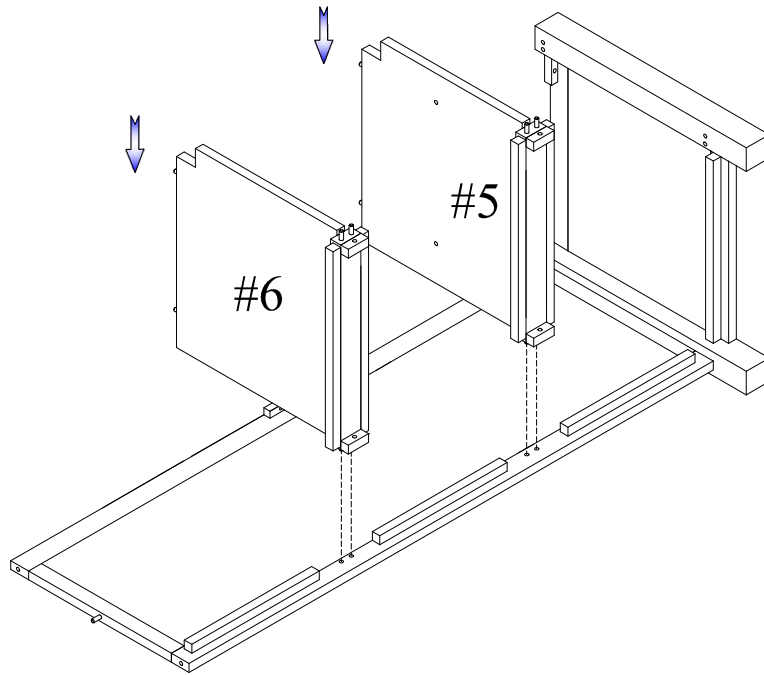
2.



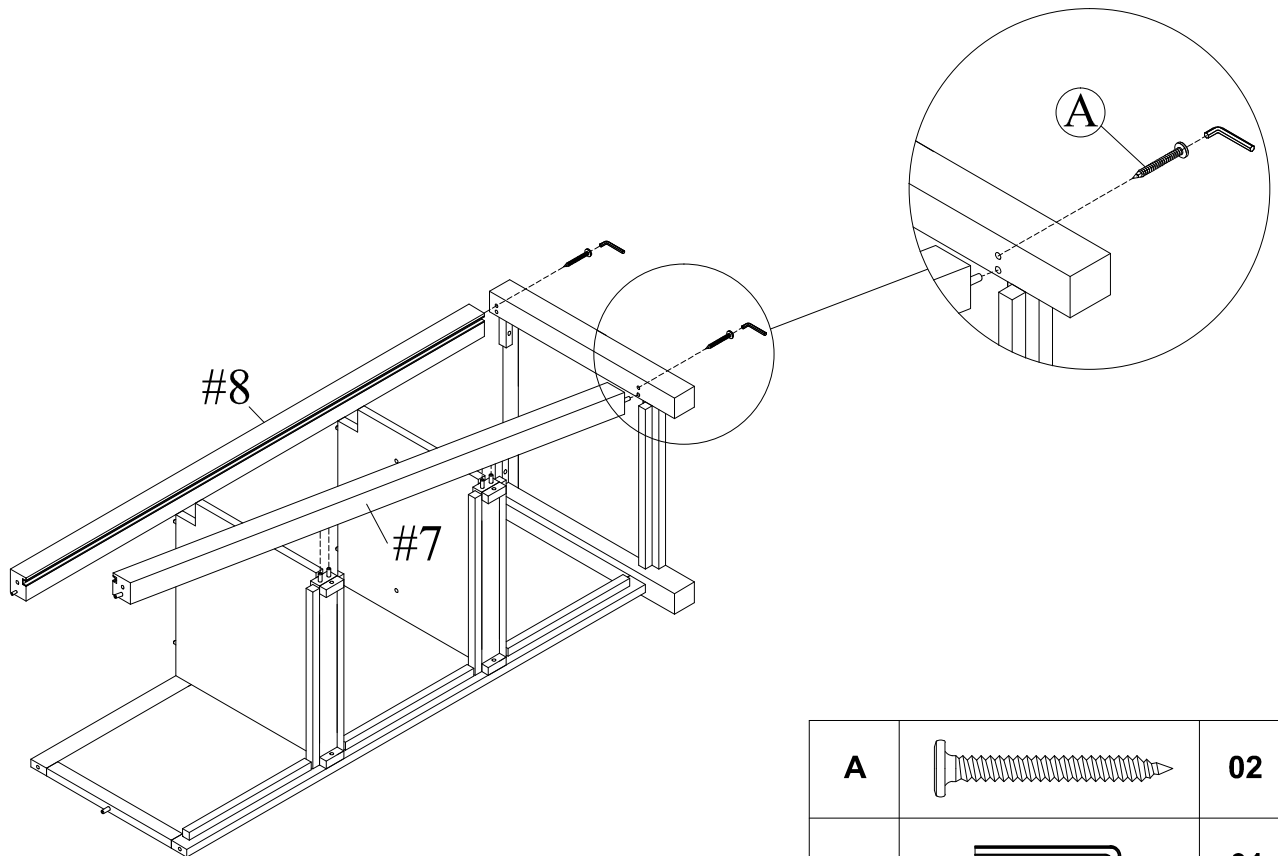

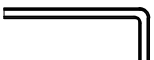

3.

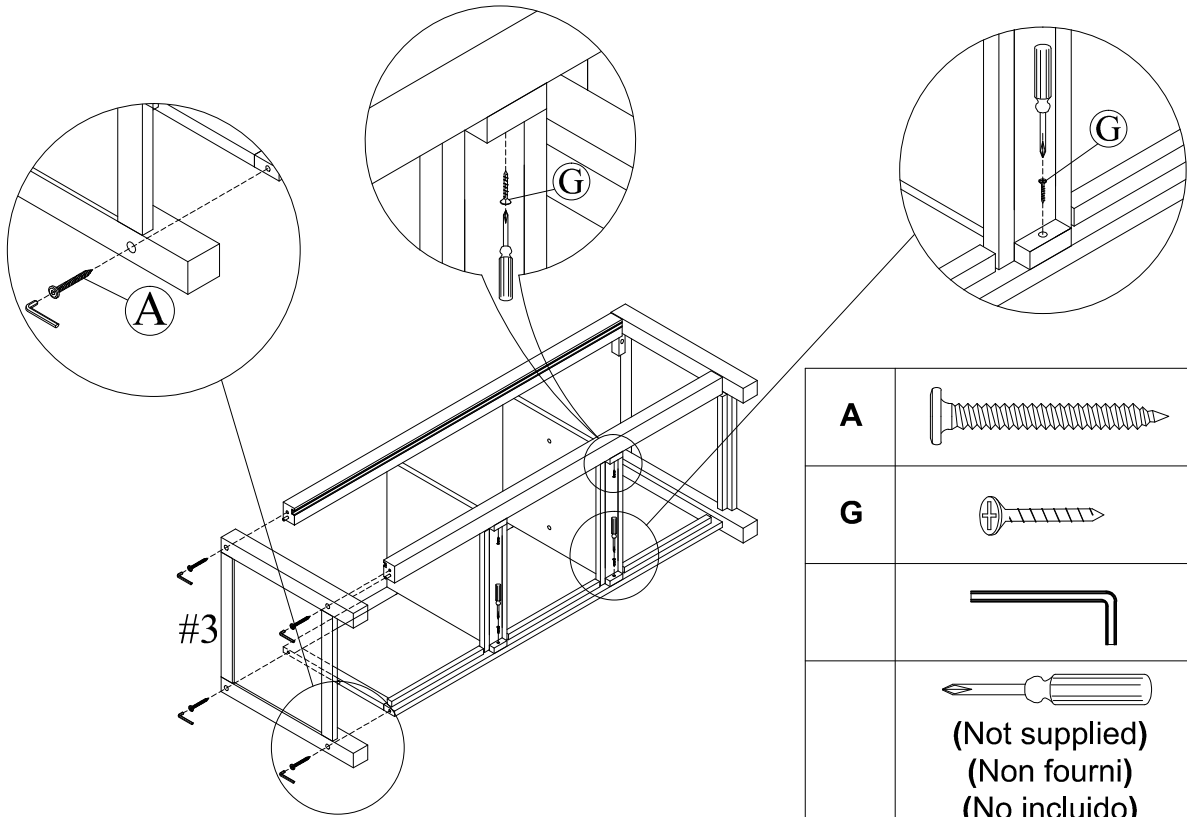

A		02
		01

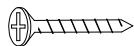

4.

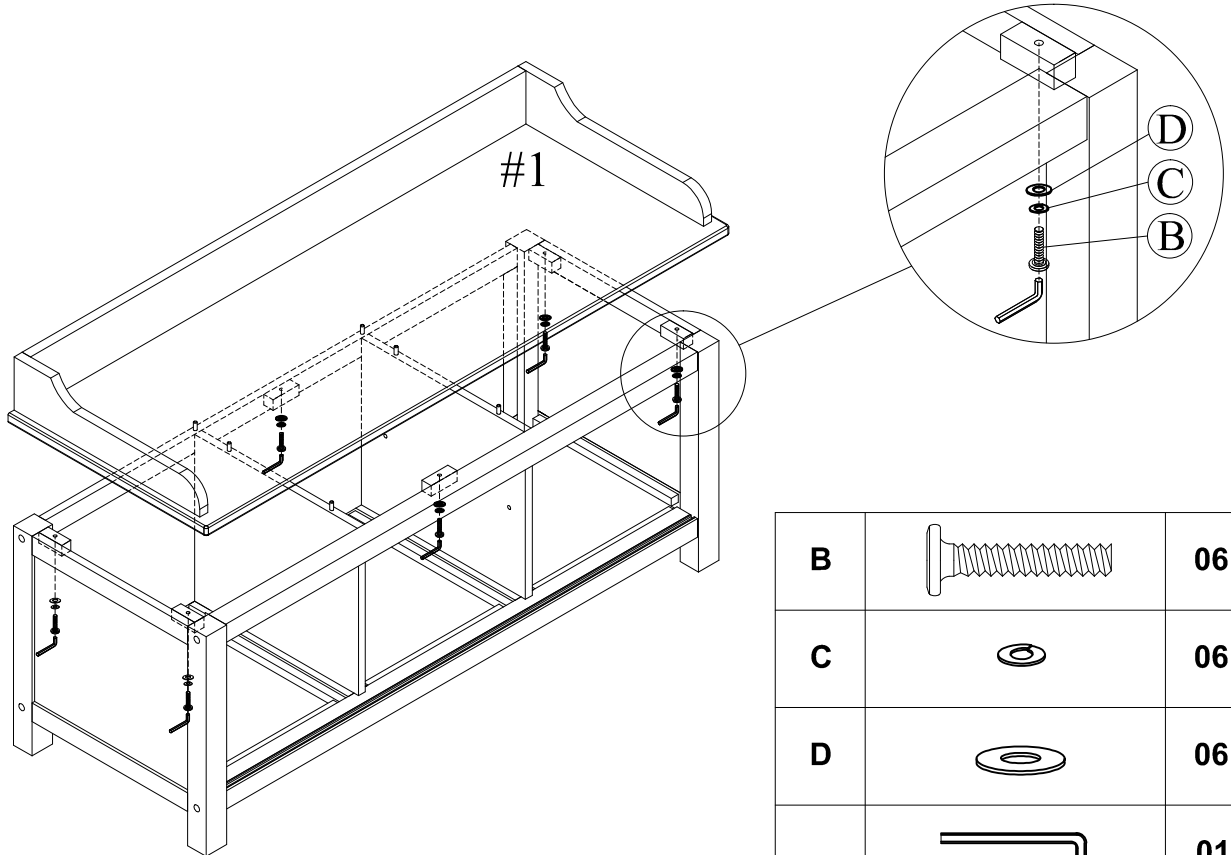

A		04
G		04
		01
	(Not supplied) (Non fourni) (No incluido)	01

5.

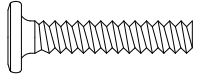

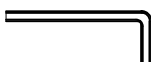

B		06
C		06
D		06
		01

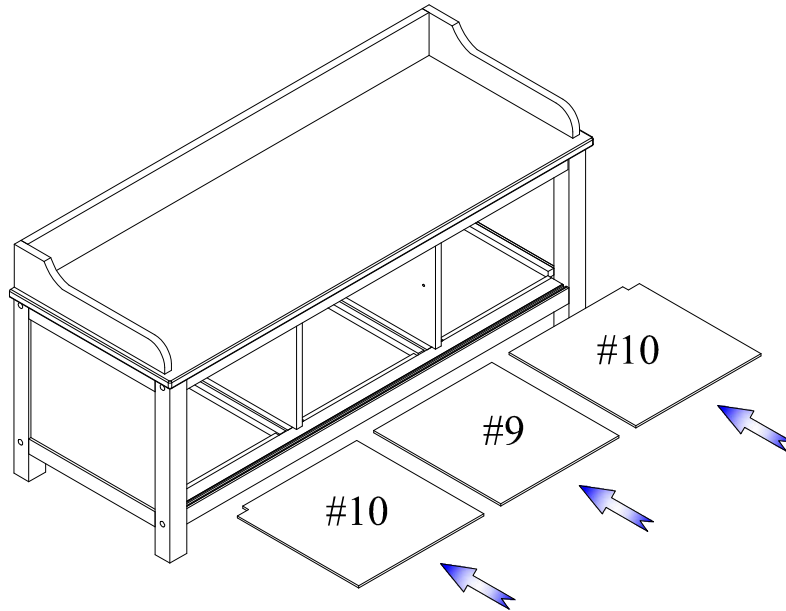
6.

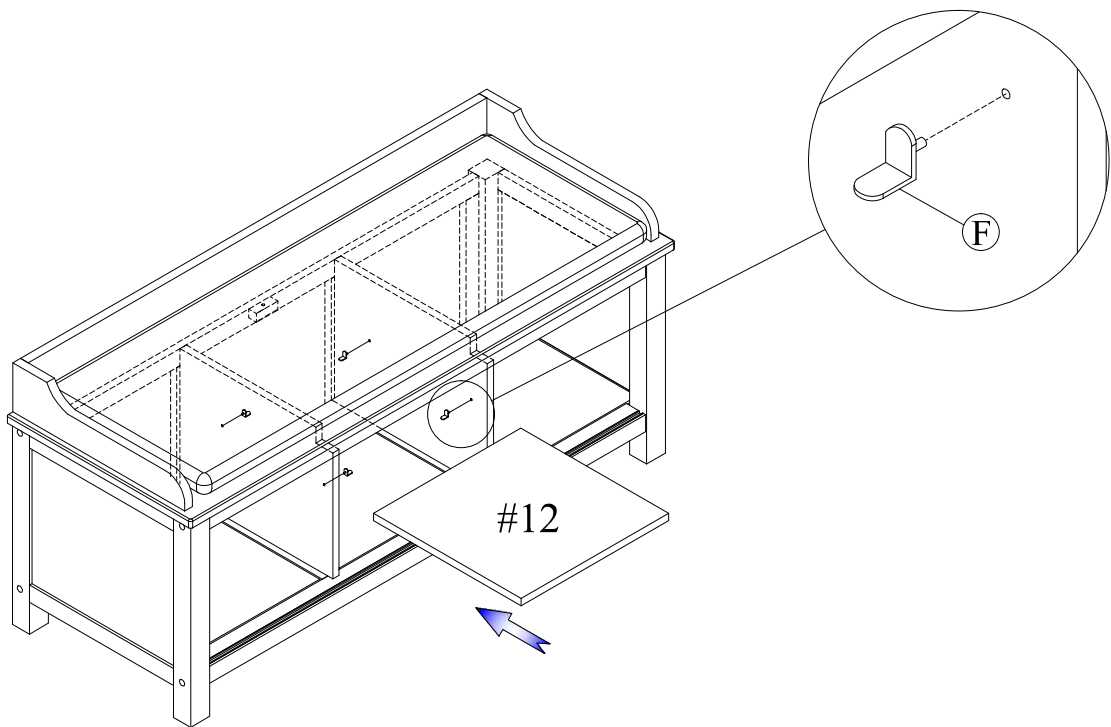

7.



F		04
---	---	----

8.

PUSH LATCH WITH INDEX FINGER

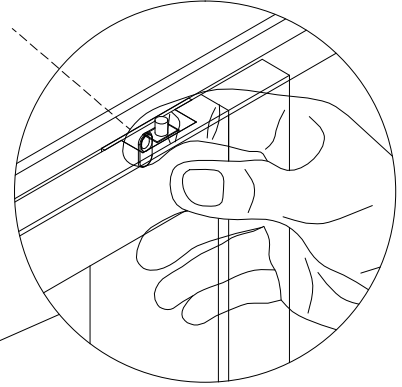
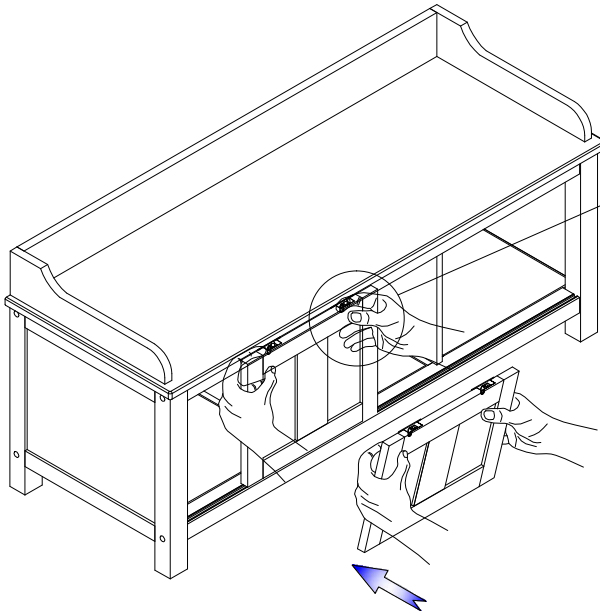

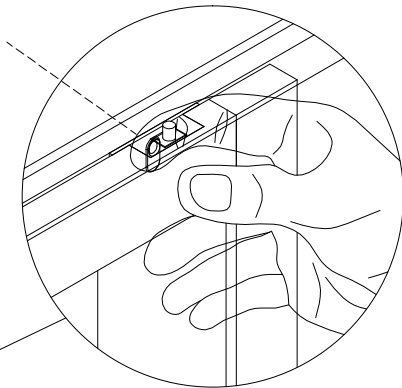
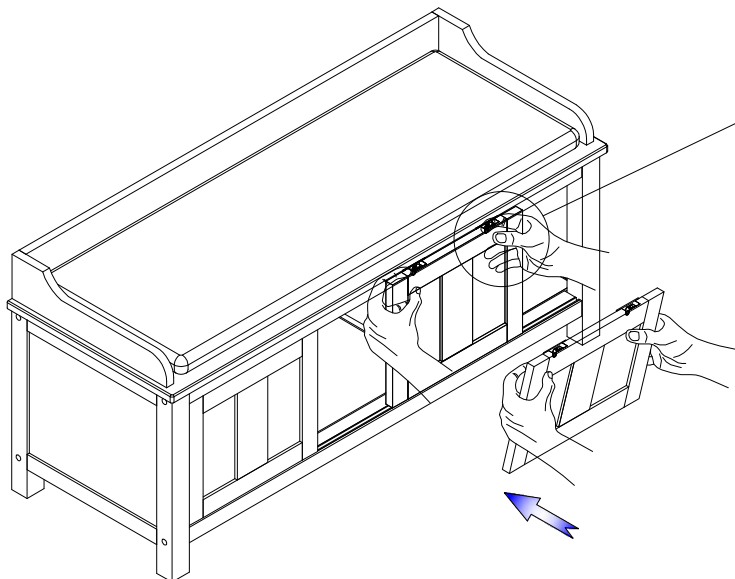

9.

PUSH LATCH WITH INDEX FINGER

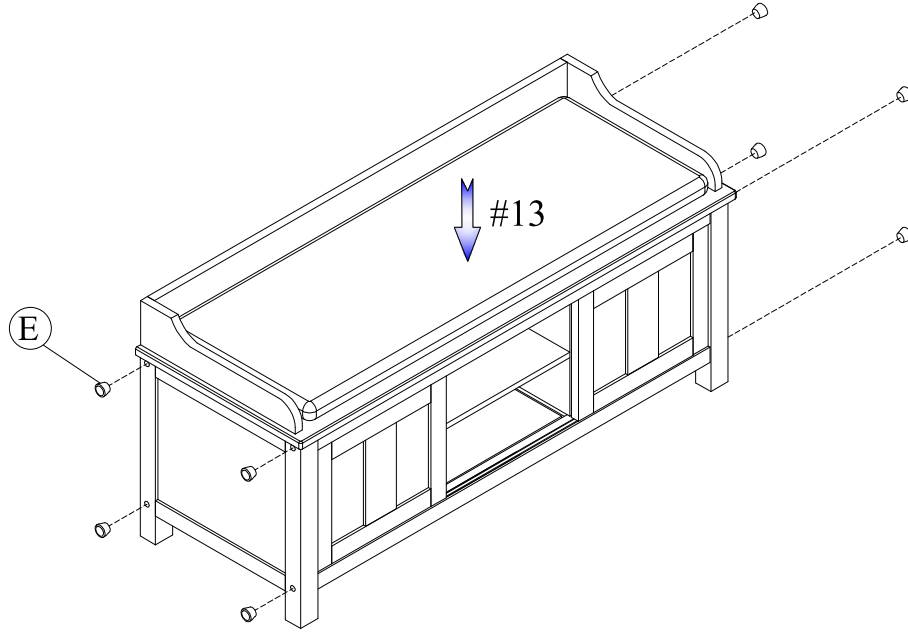

10.



E		08
---	---	----

COMPLETED ASSEMBLY

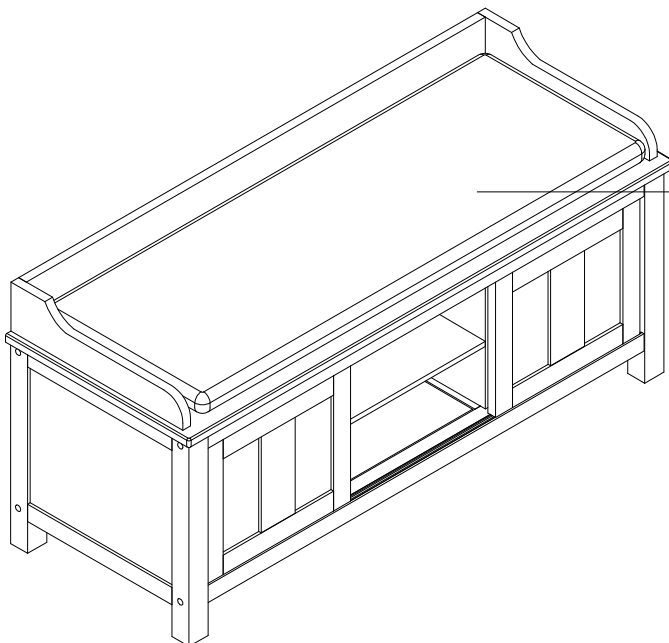

WEIGHT LIMITS
SEAT: 275 LBS