

24/7 Customer Service

We're Able to Solve All Problems For You!

Locate Your Order Number--Ask Seller For Help--Reply Within 24 Hours

Before You Start



Read

Read the instructions before operating and keep it properly.



Check

Please check if the parts are intact before starting the assembly.



Required Tools

Having these tools ready will make your assembly much easier and efficient.



Teamwork

Two or more persons are needed for assembly.



Protection

Always place the product on a flat surface or blanket to protect the parts.



24/7 Customer Service

If you have any questions or concern. We will reply you within 24 hours.

Dear Customers,

Thank you for purchasing our product. Please read this instruction manual carefully before attempting to install.



General Guidelines

1. Please read the following instructions carefully and use the product accordingly.
2. Please keep this manual and hand it over when you transfer the product.
3. This summary may not include every detail of all variations and considered steps. Please contact us when further information and help are needed.

Warnings

1. Children are not allowed to assemble the product. During assembly, keep small parts out of the reach of children as they may be fatal if swallowed or inhaled.
2. Children are not allowed to climb or stand on the product to avoid personal injury caused by the toppling.
3. Keep plastic packing bags out of reach of children to avoid any potential danger, such as suffocation.
4. Avoid sharp objects and corrosive chemicals to prevent damage to the product or the user.
5. Please do not use the product if there is/are defective and/or missing part/s, as this can result in damage or injury.

Notes

1. The item is only intended for indoor use. Personal injury and/or damage to the product may occur if products are used outside of their intended purposes and/or if products have been changed/modified from their original design. The product must be assembled and used in accordance with the provisions of the manual. The seller does not assume any responsibility or liability with respect to any damage caused by incorrect assembly or improper use.
2. Do not place it in a damp environment for extended periods of time to prevent mildew.
3. During assembly, first loosely align all screws with the corresponding pre-drilled holes.
4. Periodically inspect screw tightness while the product is in use. If necessary, re-tighten to ensure structural integrity.



Einleitung

1. Bitte lesen Sie die folgende Anleitung aufmerksam durch und verwenden Sie das Produkt sachgemäß.
2. Bewahren Sie diese Anleitung gut auf und händigen Sie sie bei Weitergabe des Produkts an Dritte ebenfalls mit aus.
3. Aus Gründen der Übersicht können nicht alle Details zu allen Varianten und denkbaren Montagen beschrieben werden. Wenn Sie weitere Informationen und Hilfe benötigen, kontaktieren Sie uns bitte.

Warnhinweise

1. Halten Sie Kinder während der Montage vom Arbeitsbereich fern. Zum Lieferumfang gehören viele Kleinteile, die beim Verschlucken oder Inhalieren lebensgefährlich sein können.
2. Um durch Umkippen verursachte Verletzungen zu vermeiden, dürfen sich Kinder unter keinen Umständen auf das Produkt stellen, auf dieses klettern oder damit spielen.
3. Verwahren Sie Verpackungsteile nur an Orten, die Kindern, insbesondere Säuglingen, nicht zugänglich sind. Verpackungsteile bergen oftmals nicht erkennbare Gefahren (z.B. Erstickungsgefahr).
4. Das Produkt darf nicht mit scharfen Gegenständen und aggressiven chemischen Substanzen in Kontakt kommen, um Beschädigungen zu vermeiden.
5. Verwenden Sie das Produkt bitte nicht, wenn Teile fehlen oder defekt sind.

Hinweise

1. Das Produkt ist zum Gebrauch in Innenräumen vorgesehen. Montieren und verwenden Sie das Produkt nur wie in dieser Anleitung beschrieben. Eine andere Verwendung oder eine Veränderung/ein Umbau des Produktes ist nicht erlaubt und kann zu Verletzungen und/oder Beschädigungen des Produktes führen. Der Händler übernimmt keine Haftung für Schäden, die durch unsachgemäßen Gebrauch oder falsche Montage entstanden sind.
2. Stellen Sie das Produkt bitte nicht über einen längeren Zeitraum in einer feuchten Umgebung auf, um Schimmel zu vermeiden.
3. Ziehen Sie die Schrauben bei der Montage bitte nicht sofort an. Erst nachdem Sie alle Schrauben in die vorgebohrten Öffnungen eingesetzt haben, sollten Sie diese vorsichtig festziehen.
4. Prüfen Sie regelmäßig den festen Sitz der Schrauben, denn diese können sich mit der Zeit lösen, was zum Umkippen des Produktes führen könnte. Falls notwendig, sollten Sie die Schrauben nachziehen.



Introduction

1. Lisez attentivement ces instructions et utilisez votre produit d'après ce mode d'emploi.
2. Conservez ces instructions. Si vous souhaitez offrir ce produit à la troisième partie, joignez obligatoirement ce mode d'emploi.
3. Cette instruction ne peut pas inclure tous les détails de toutes les variations et étapes envisagées. Si vous souhaitez obtenir plus d'informations ou si vous rencontrez certains problèmes non traités de manière détaillée dans ces instructions, veuillez nous contacter.

Avertissements

1. Gardez toutes les pièces hors de la portée des enfants, il peut être mortel en cas d'ingestion ou d'inhalation.
2. Il est interdit aux enfants de monter sur le produit ou de jouer avec. Le renversement du produit causerait des accidents, avec des risques plus ou moins graves.
3. Pour éviter les dangers potentiels (par exemple les étouffements), gardez les emballages (films, sacs plastiques, polystyrènes, etc.) hors de la portée des enfants.
4. Évitez tout contact avec des objets pointus et des produits chimiques corrosifs.
5. N'utilisez jamais ce produit dans le cas de manque ou défectuosité des pièces pour éviter le danger potentiel.

Notes

1. Le produit est destiné uniquement à un usage intérieur. Il doit être assemblé et utilisé conformément aux instructions. Les utilisations qui ne correspondent pas à la description ci-dessus ou les transformations de l'article ne sont pas autorisées. Le vendeur ne prend aucune responsabilité aux dommages causés par un montage incorrect ou une utilisation non conforme.
2. Ne placez pas le produit dans un environnement à humidité élevée afin d'éviter le développement des moisissures.
3. Veuillez d'abord positionner et régler les pièces en faisant référence à la notice de montage, puis effectuer un serrage progressif.
4. Vérifiez régulièrement le serrage des vis. En cas de nécessité, resserrez les resserrez.



Linee Guida Generali

1. Si prega di leggere attentamente le seguenti istruzioni e usare il prodotto in modo opportuno.
2. Si prega di conservare questo manuale e consegnarlo quando il prodotto cambia proprietario.
3. Questo riassunto potrebbe non includere ogni dettaglio di tutte le variazioni e le fasi considerate. Contattaci se hai bisogno di ulteriori informazioni e assistenza.

Avvertenze

1. I bambini non sono autorizzati a montare il prodotto. Durante l'assemblaggio, si raccomanda di tenere i bambini a debita distanza, in quanto alcune parti di piccole dimensioni potrebbero essere ingerite con conseguenze dannose per la salute.
2. I bambini non sono autorizzati a stare in piedi, arrampicarsi o giocare sul prodotto per evitare gravi lesioni fisiche a causa del ribaltamento.
3. Tenere gli imballaggi di plastica fuori dalla portata dei bambini per evitare potenziali pericoli come soffocamento.
4. Evitare l'utilizzo di oggetti taglienti e sostanze chimiche corrosive per prevenire danni al prodotto o lesioni personali.
5. Si prega di non utilizzare il prodotto in caso di parti difettose e/o mancanti, in quanto ciò può causare danni lesioni.

Note

1. Il prodotto è inteso per uso interno. Si prega di seguire attentamente le istruzioni per montare e usare il prodotto. L'uso non conforme alla descrizione, o cambio o modifica non autorizzata del prodotto, non è consentito e può provocare lesioni e/o danni al prodotto.
Il venditore non si assume alcuna responsabilità per danni o lesioni derivanti da montaggio o uso impropri.
2. Evitare l'esposizione a lungo termine in ambienti umidi per evitare la formazione di muffe.
3. Non stringere completamente le viti fino a quando tutte le viti sono allineate con i fori preforati corrispondenti.
4. Controllare regolarmente le viti. Poiché le viti possono allentarsi durante l'uso prolungato. Se necessario, riavvitarle per garantire stabilità e sicurezza.



Acerca del manual

1. Por favor, lea detenidamente las instrucciones y respete los debidos usos del producto.
2. Por favor, conserve bien este manual y en caso de cesión, no omita entregarlo junto al producto.
3. Este manual podría no incluir todos los detalles de cada paso del montaje. Si necesita ayuda o información adicional, póngase en contacto con nosotros.

Advertencias

1. Los niños no están autorizados a montar el producto. Durante el montaje, mantenga las piezas pequeñas fuera del alcance de los niños, ya que pueden ser mortales si se ingieren o inhalan.
2. No se permite que los niños se suban o se suban al producto para evitar lesiones personales causadas por el vuelco.
3. Mantenga las bolsas de plástico fuera del alcance de los niños para evitar cualquier peligro potencial, como la asfixia.
4. Evite los objetos punzantes y los productos químicos corrosivos para evitar daños al producto o al usuario.
5. Por favor, no utilice el producto si está defectuoso y/o le faltan piezas, ya que esto puede ocasionar daños o lesiones.

Notas

1. El artículo sólo está destinado a ser utilizado en interiores. Pueden ocurrir lesiones personales y/o daños al producto si los productos se utilizan fuera de su uso previsto y/o si los productos han sido cambiados/modificados de su diseño original. El producto debe ser montado y utilizado de acuerdo con las disposiciones del manual. El vendedor no asume ninguna responsabilidad con respecto a cualquier daño causado por un montaje incorrecto o un uso inadecuado.
2. No lo coloque en un ambiente húmedo por largos períodos de tiempo para prevenir el moho.
3. Durante el montaje, alinee primero todos los tornillos con los orificios pretaladrados correspondientes y, a continuación, apriete los tornillos uno por uno.
4. Inspeccione periódicamente el apriete de los tornillos mientras el producto está en uso. Si es necesario, vuelva a apretar para asegurar la integridad estructural.

REMINDERS



- Please feel free to contact us by email if you have any questions or concern. We will reply you within 24 hours.

Required Tools

Having these tools ready will make your assembly much easier and efficient.

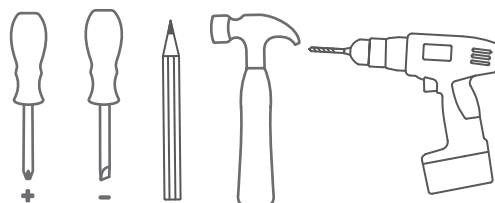

Safe assembly

Assemble the item on a clean flat surface.

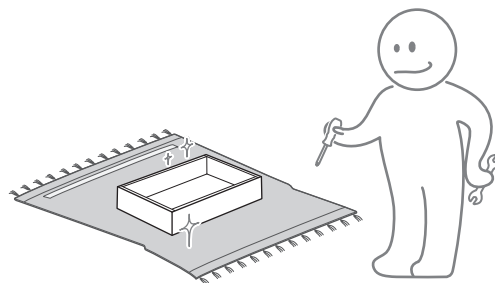

Teamwork

Two or more persons are needed for assembly.

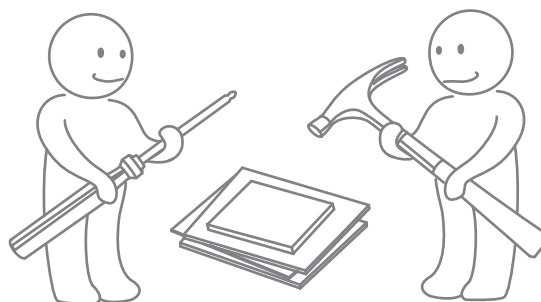

Read

Read the instructions before operating and keep it properly.

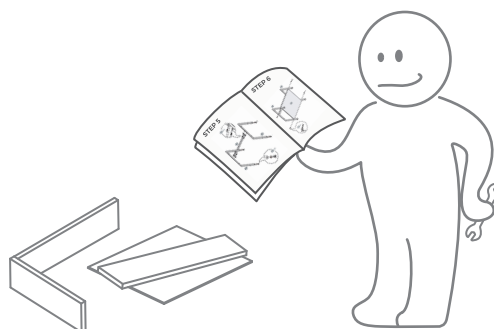

EXPLODED

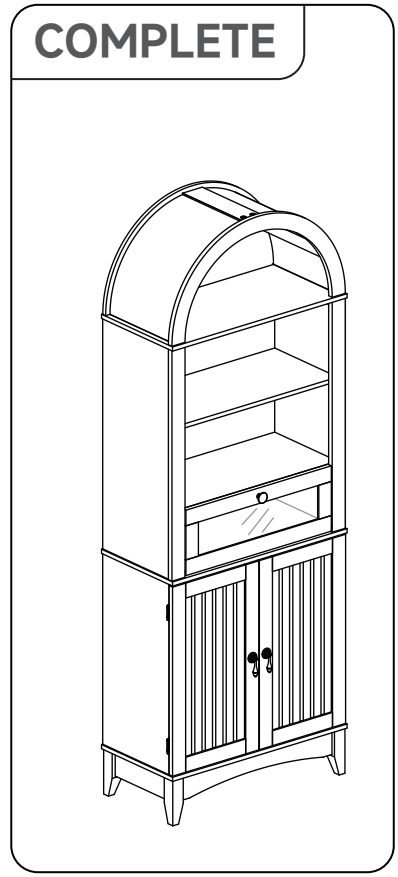
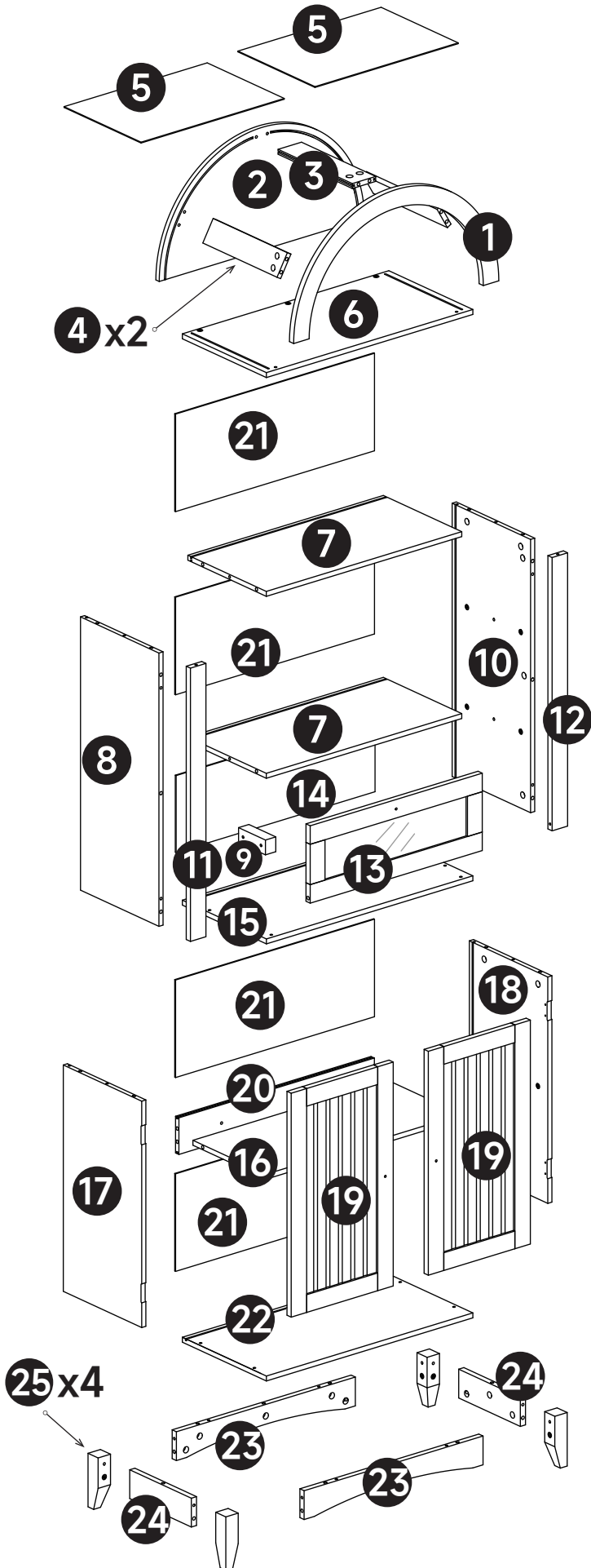

PARTS LIST

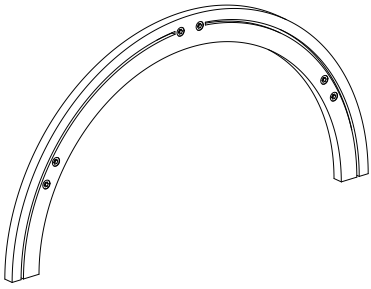

1 x1

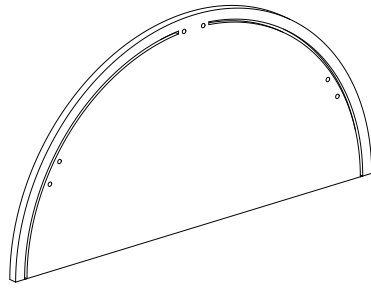

2 x1



3 x1



4 x2

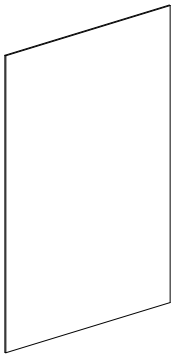

5 x2

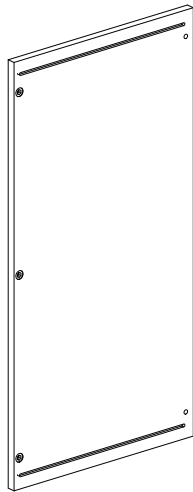

6 x1

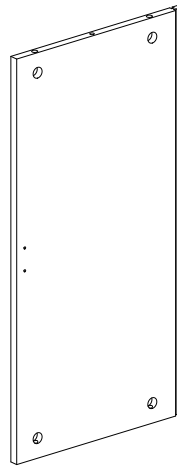

7 x2

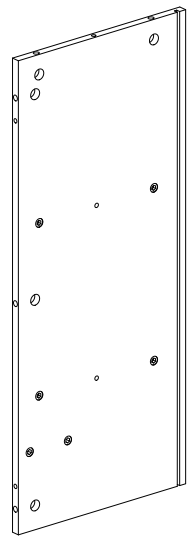

8 x1

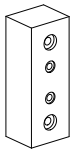

9 x1

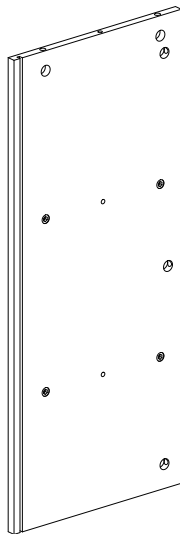

10 x1



11 x1



12 x1

PARTS LIST

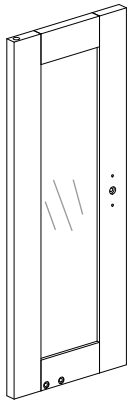

13 x1

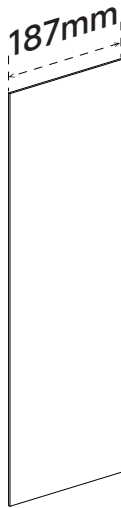

14 x1

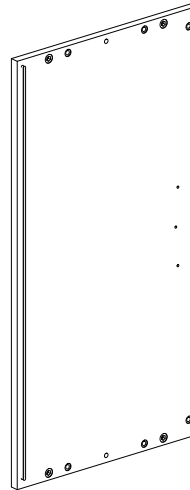

15 x1

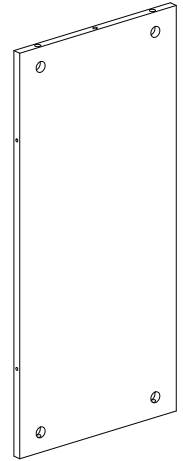

16 x1

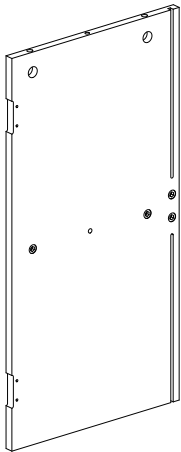

17 x1

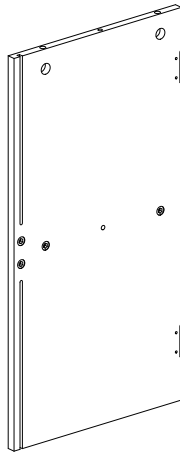

18 x1

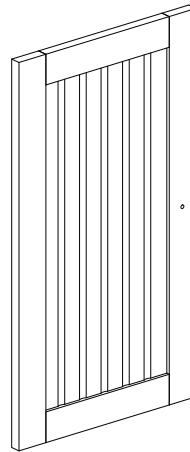

19 x2

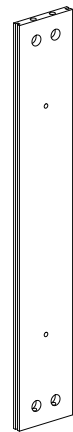

20 x1

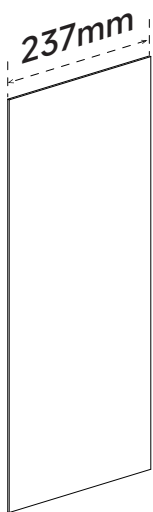

21 x4

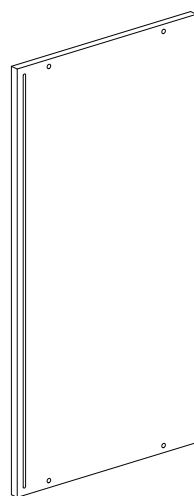

22 x1

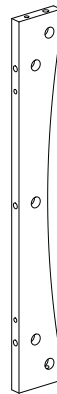

23 x2

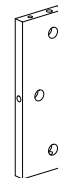

24 x2

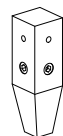

25 x4

HARDWARE LIST

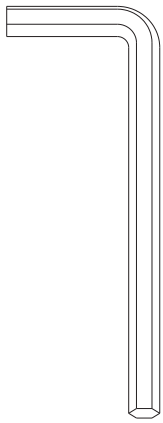

A x1

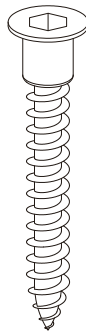

B x20

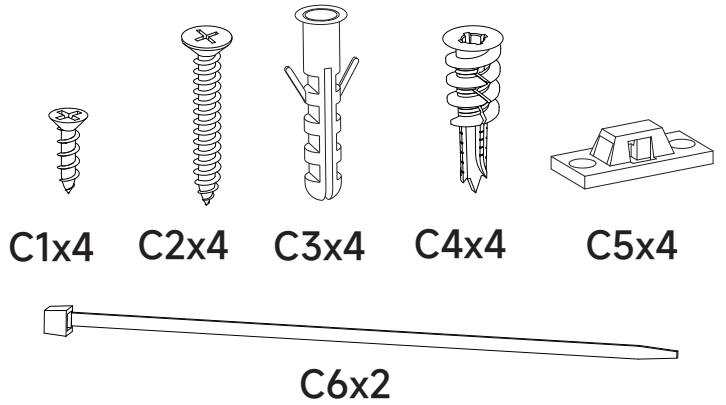

C

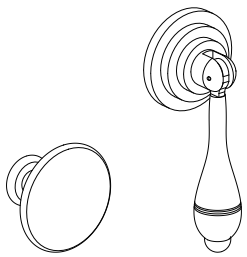

D1x1

D2x2

D3x3

D x1



E x28



F1



F2

F x55

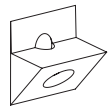

G x20



H x25



I x22



J x4

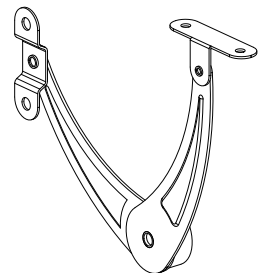

K x1

HARDWARE LIST

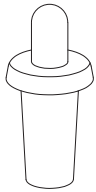

L x2

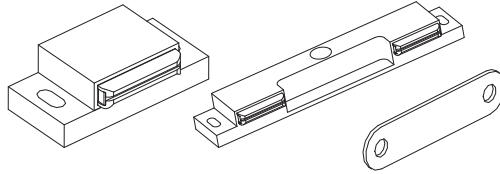

M1x1

M2x1

M3x3

M

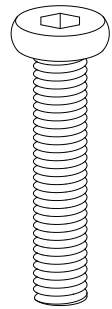

N x2

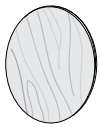

Sticker

O x14

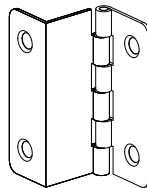

P x4

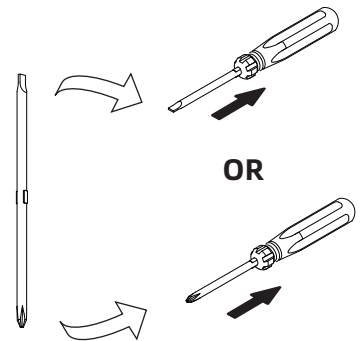

Prepared Tools:

STEP 1



- During assembly, please align and tighten all screws with the corresponding pre-drilled holes.
- Note: It is recommended to complete the assembly on flat ground or carpet.

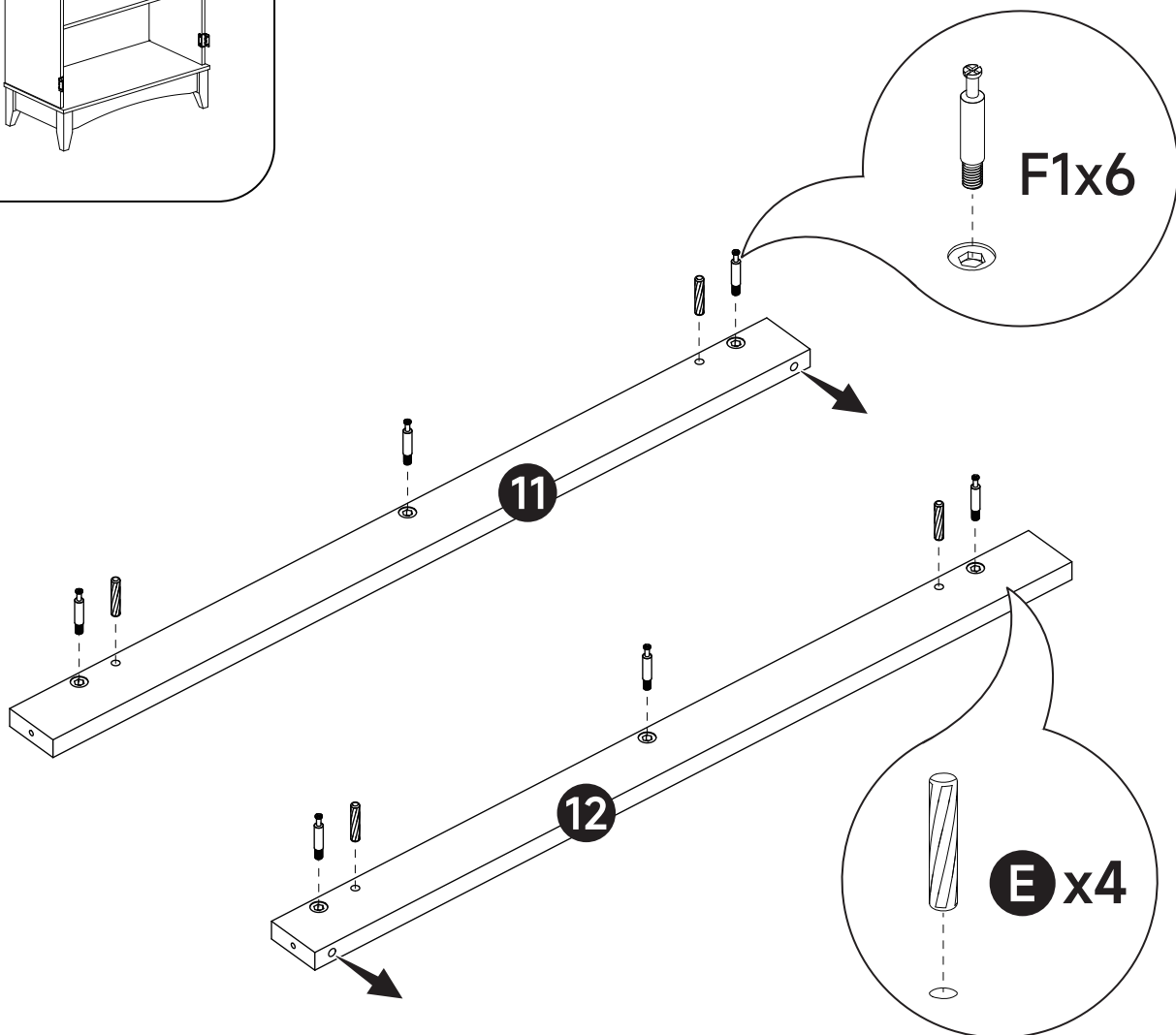
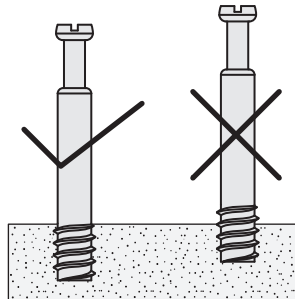
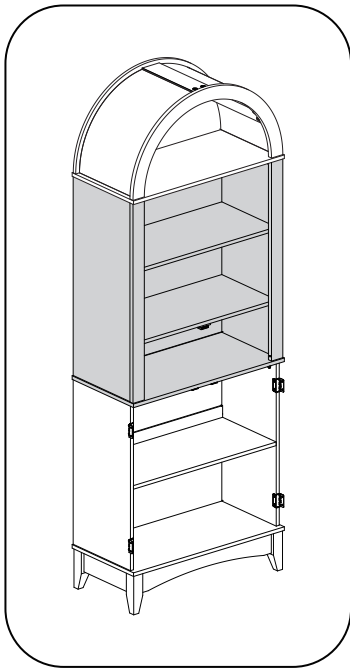

STEP 2



 Note the direction of the holes.

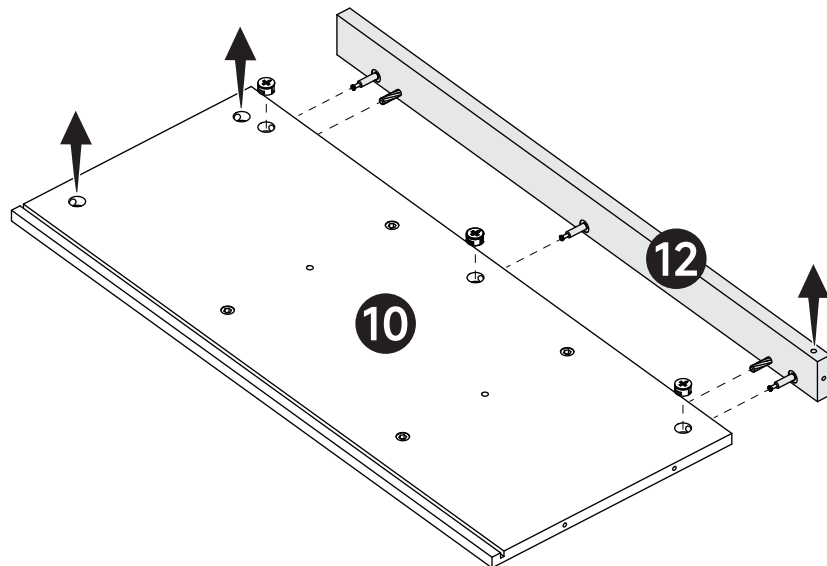
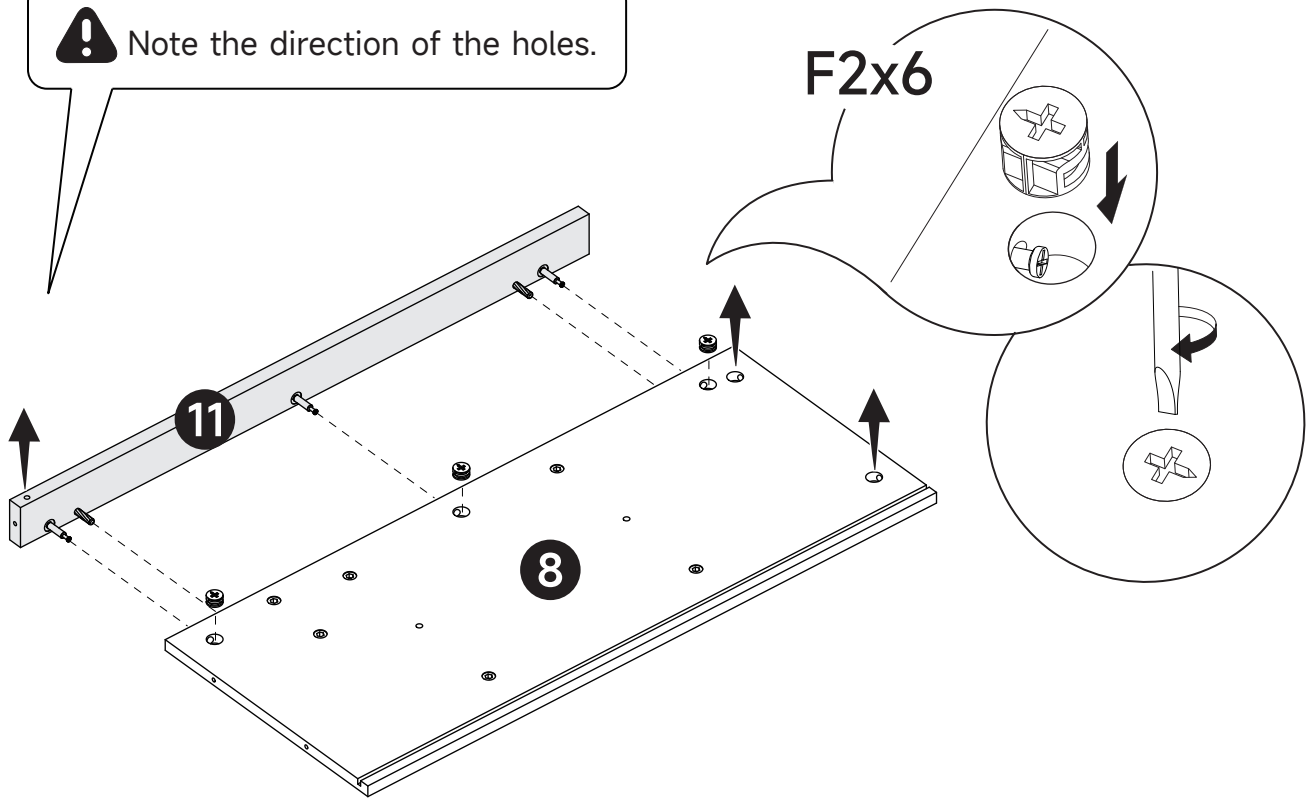

STEP 3

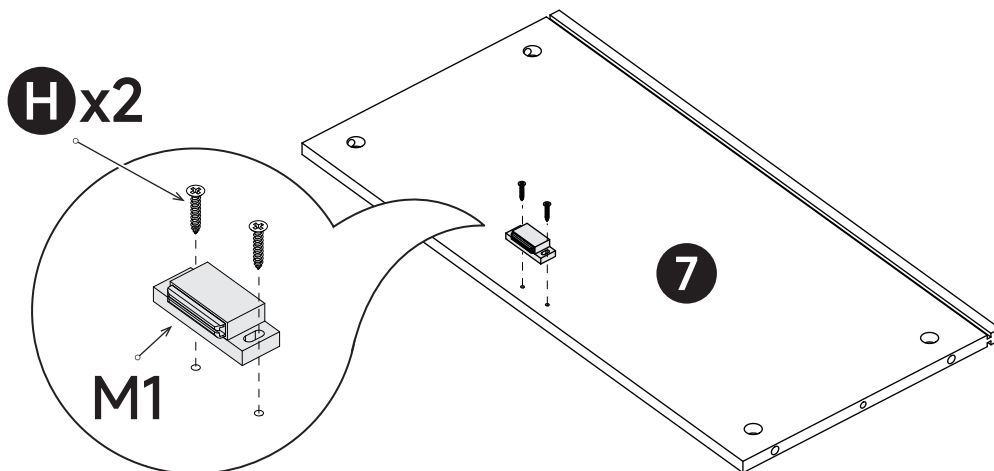
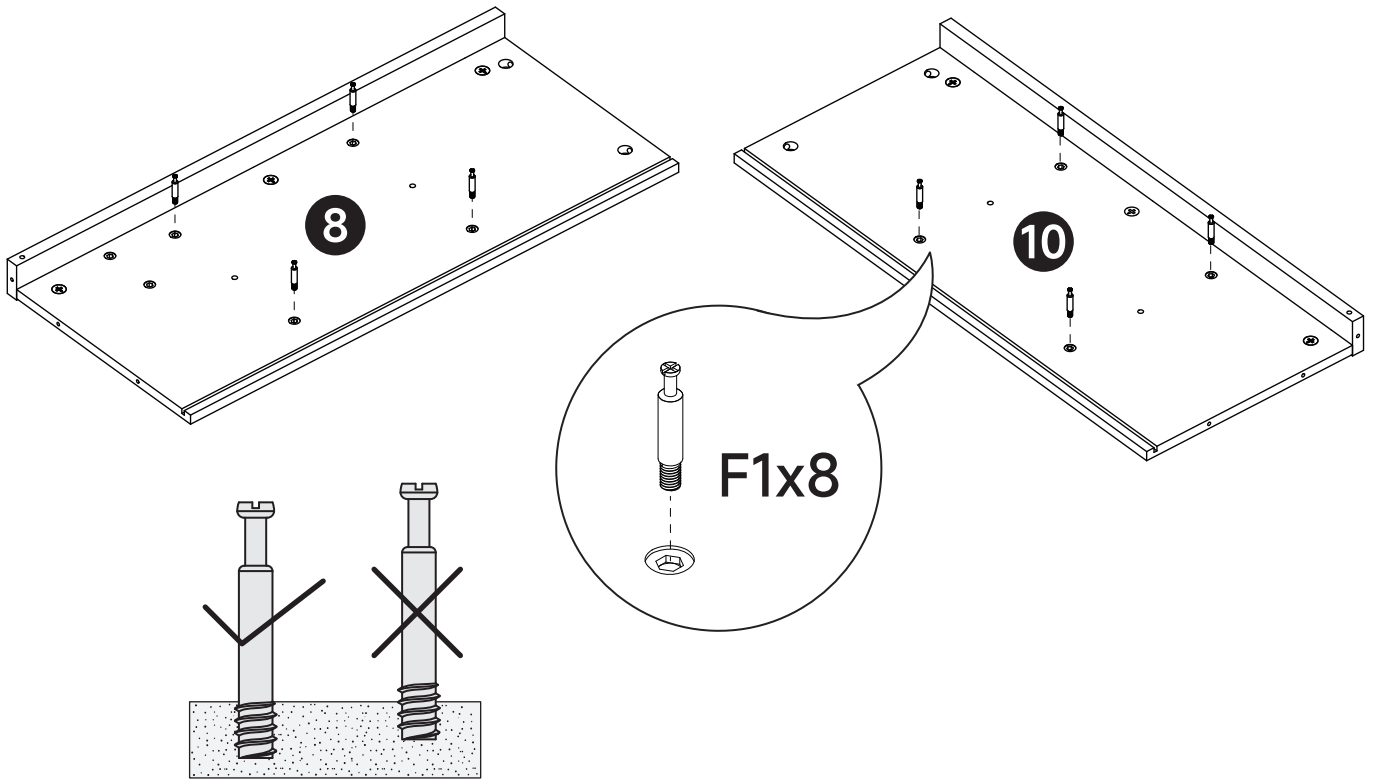

STEP 4

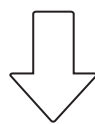
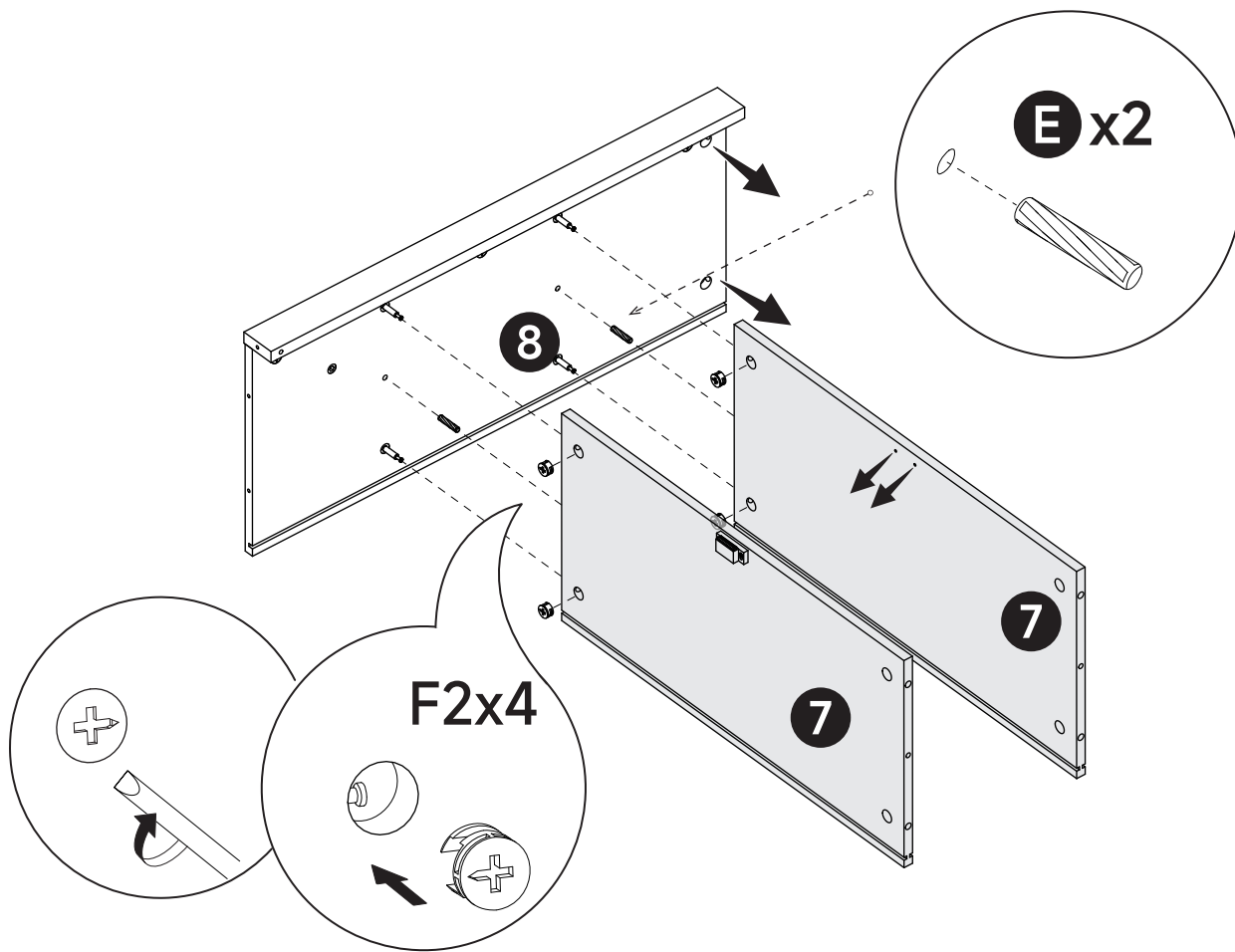

 Note the direction of the holes.

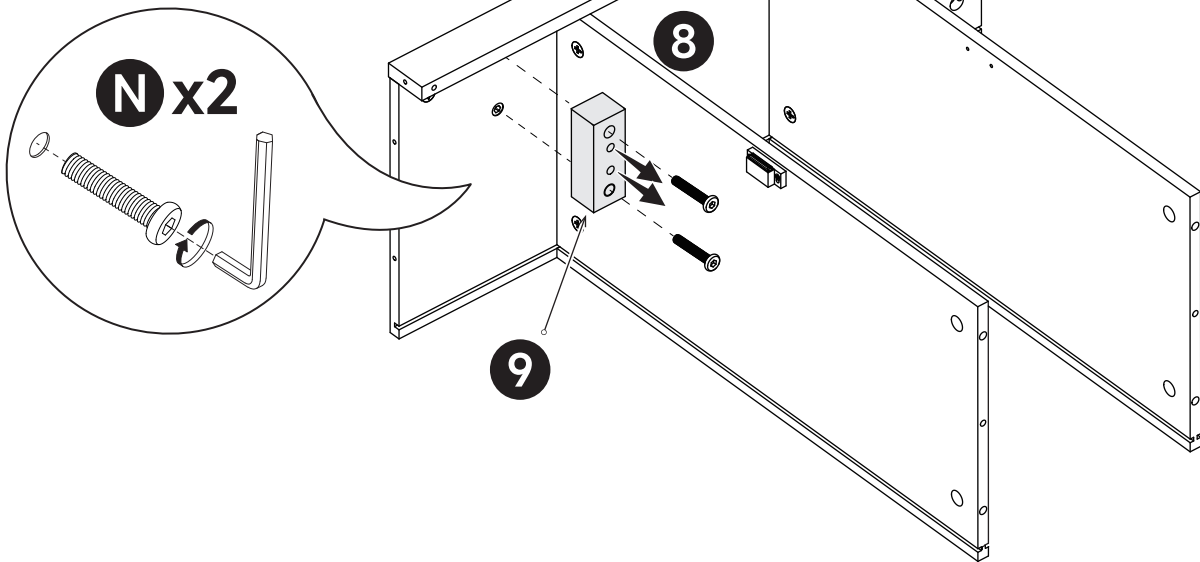

STEP 5

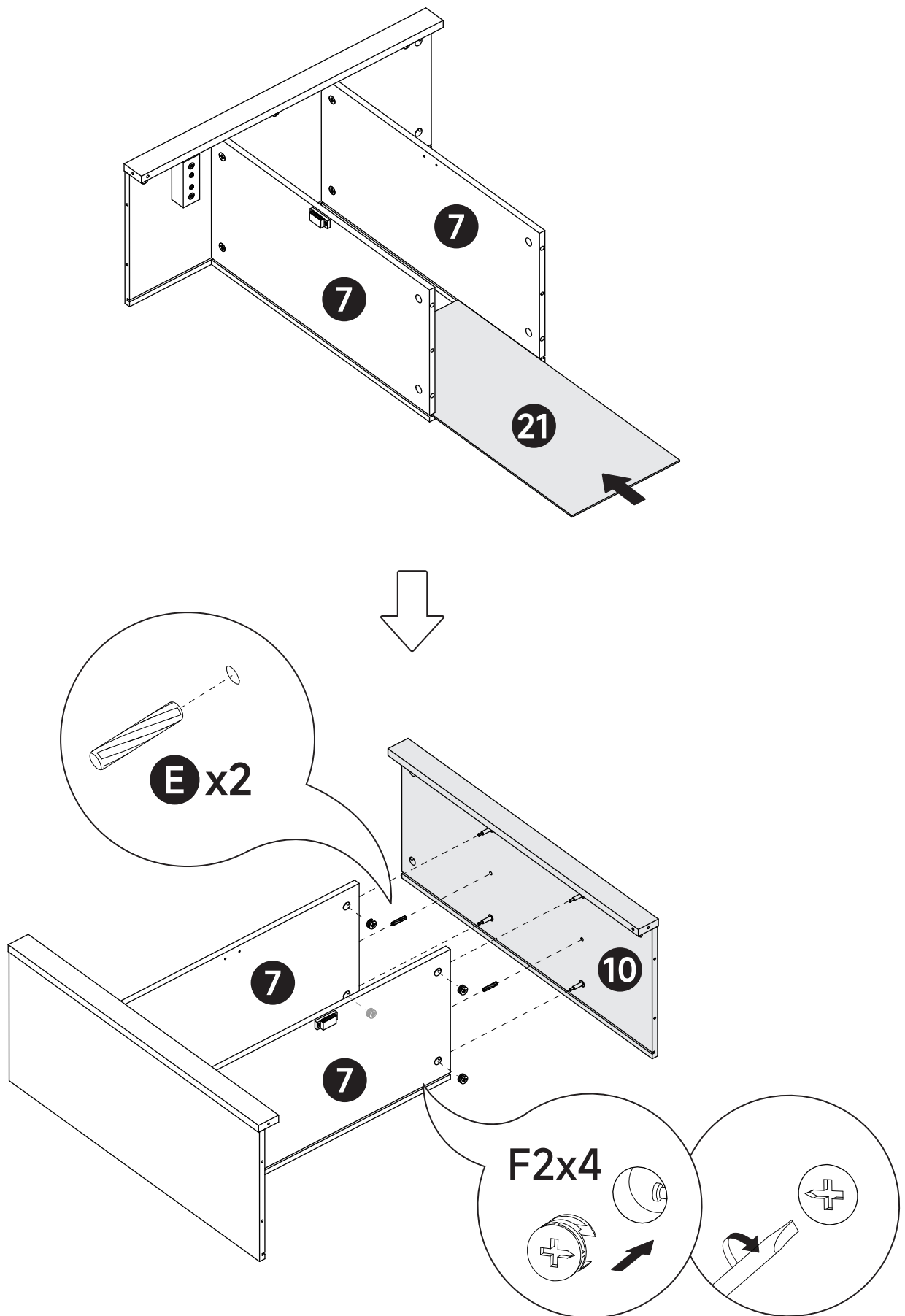

STEP 6

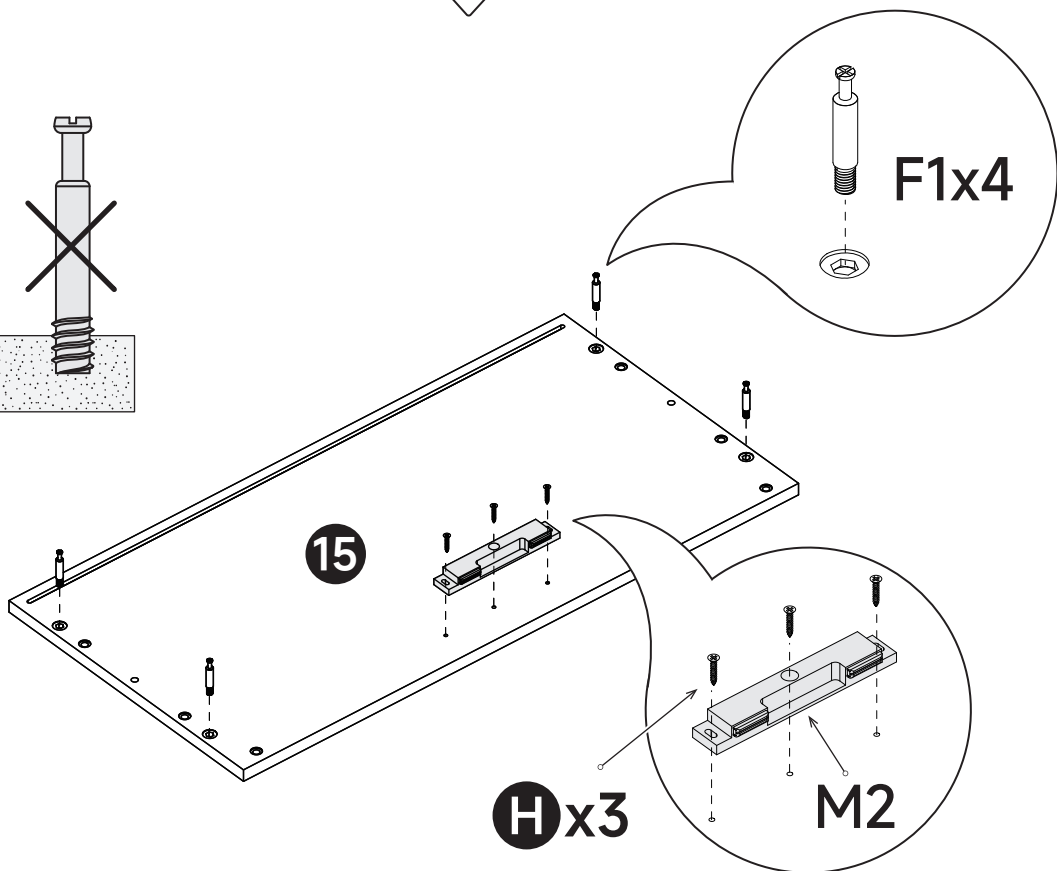
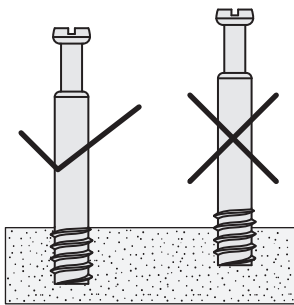
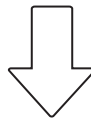
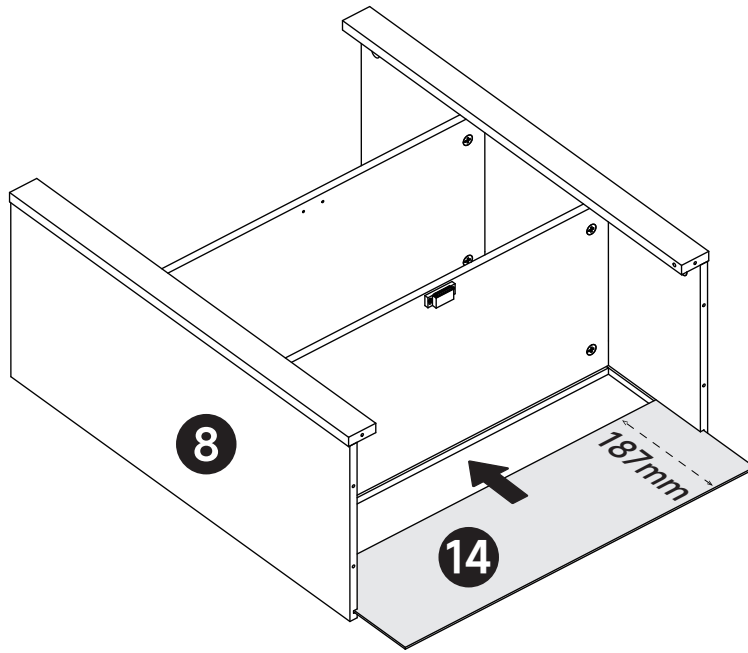

STEP 7

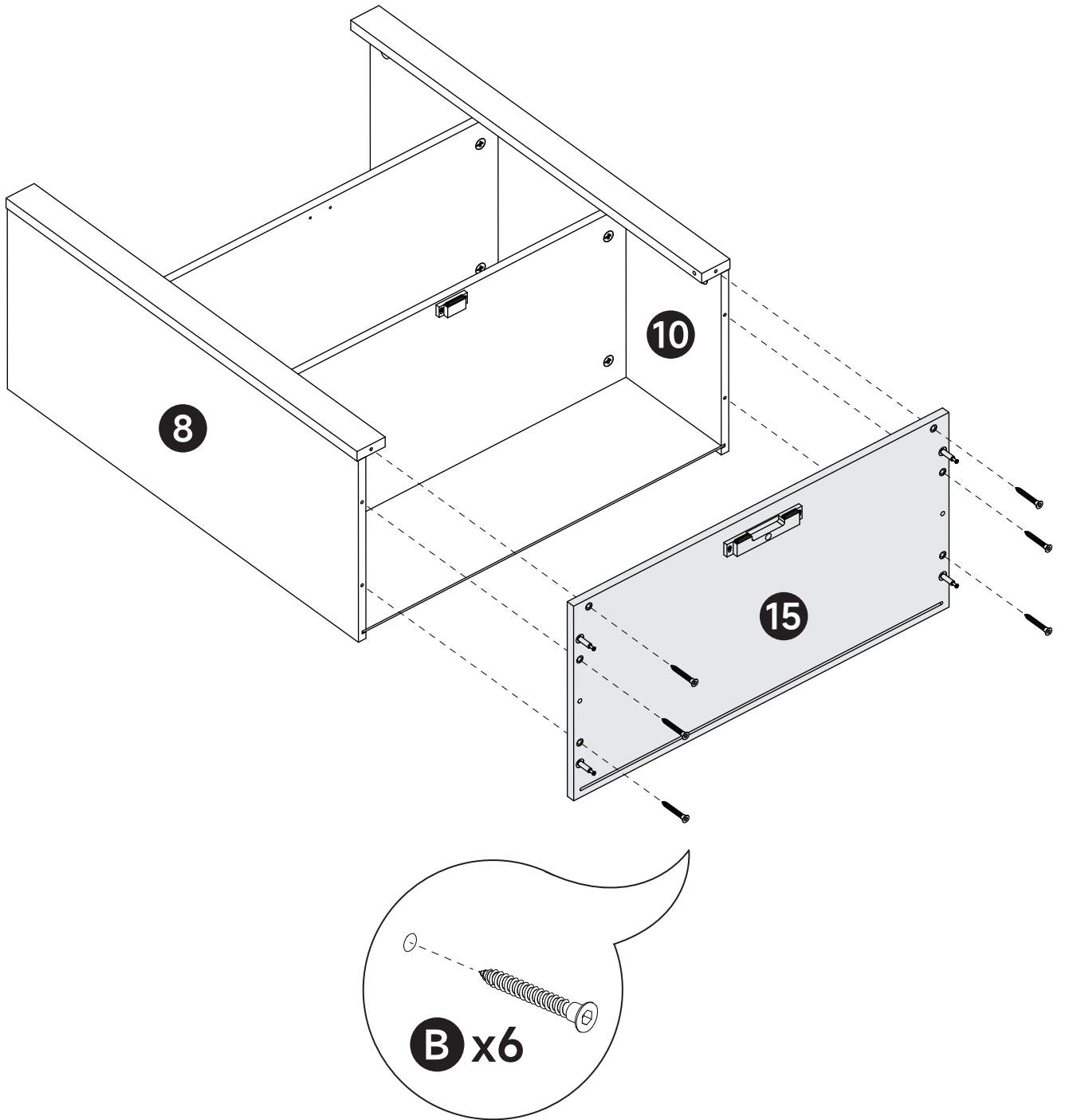

STEP 8

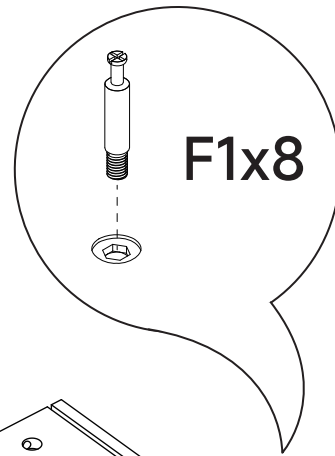
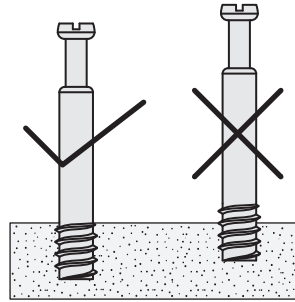
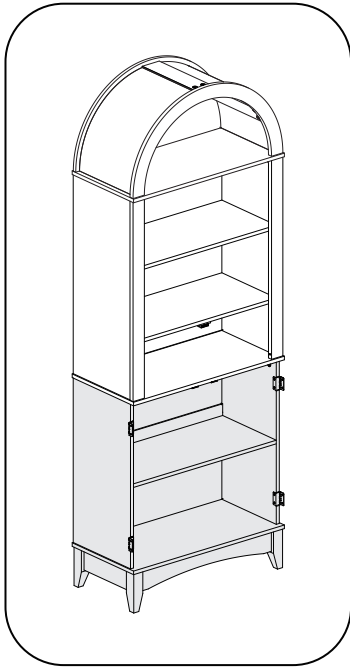

F1x8

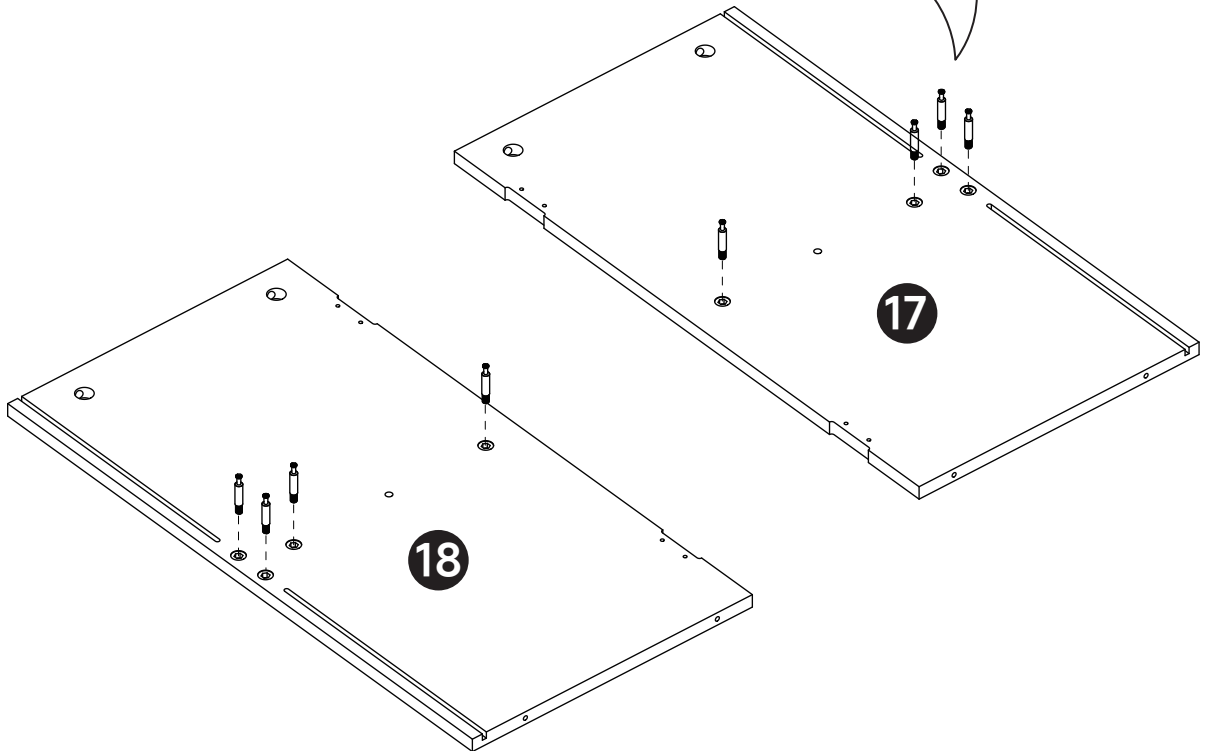

STEP 9

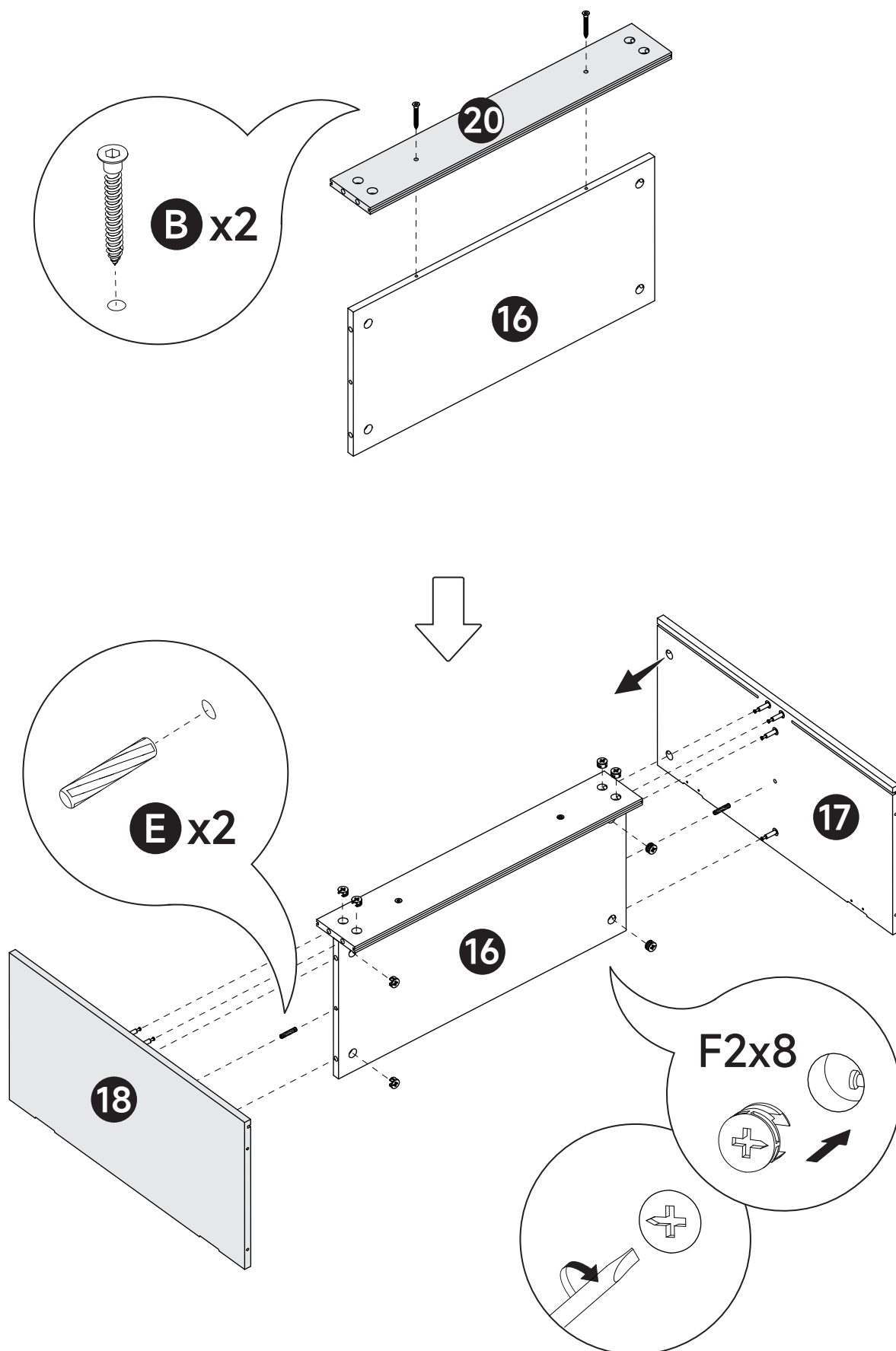

STEP 10

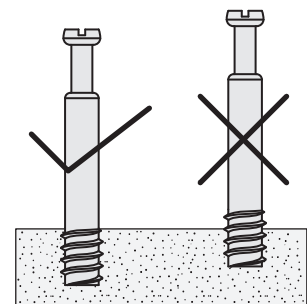
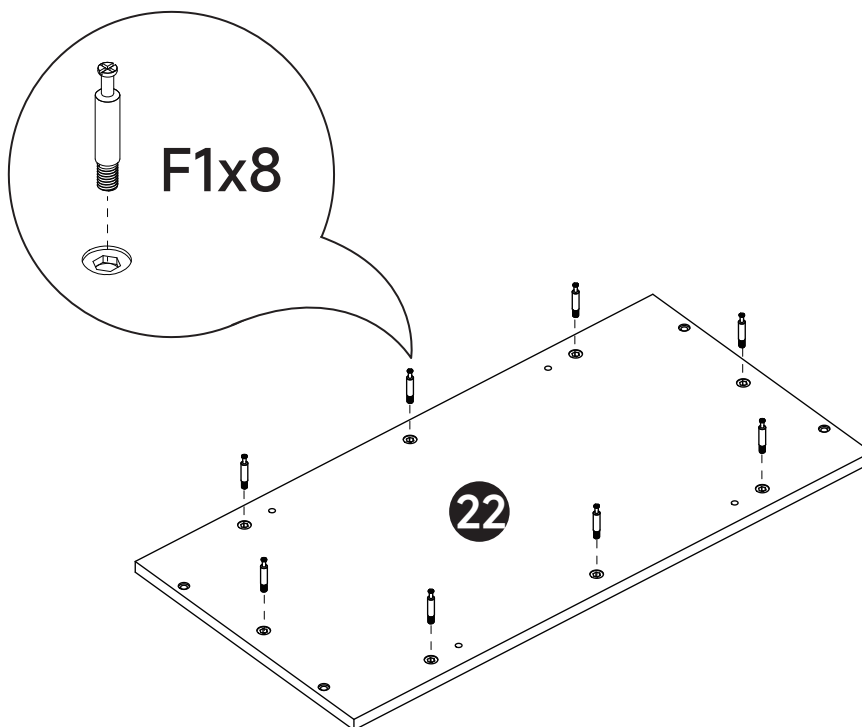
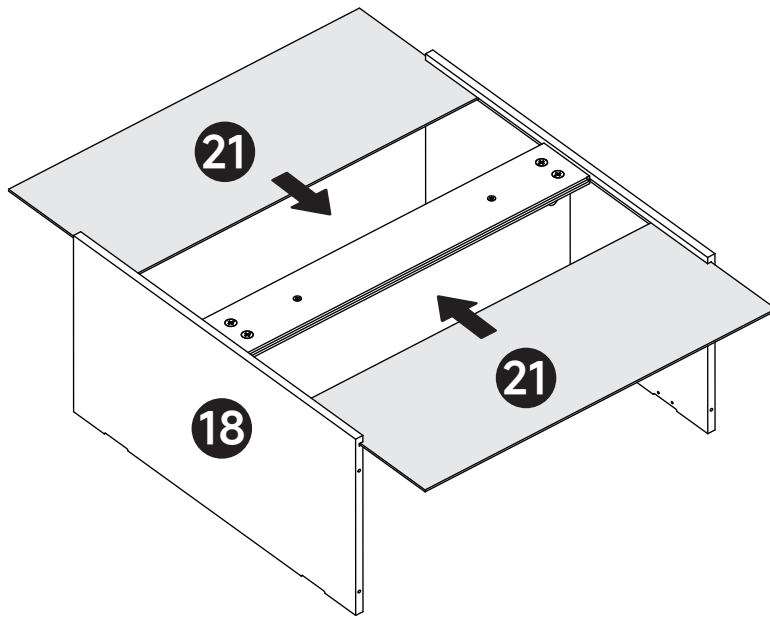

STEP 11

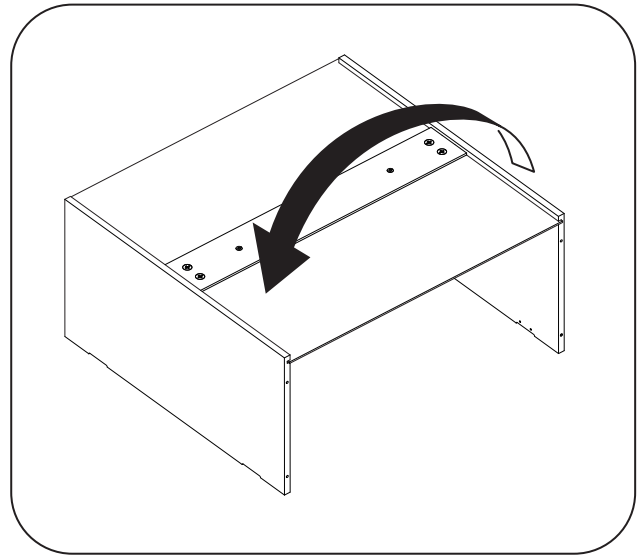

P x4

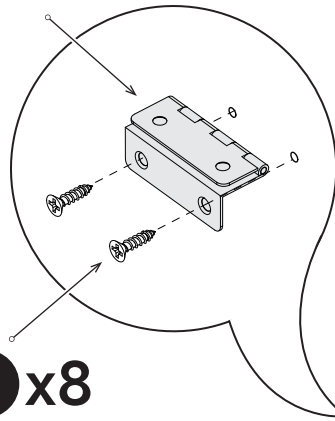

I x8

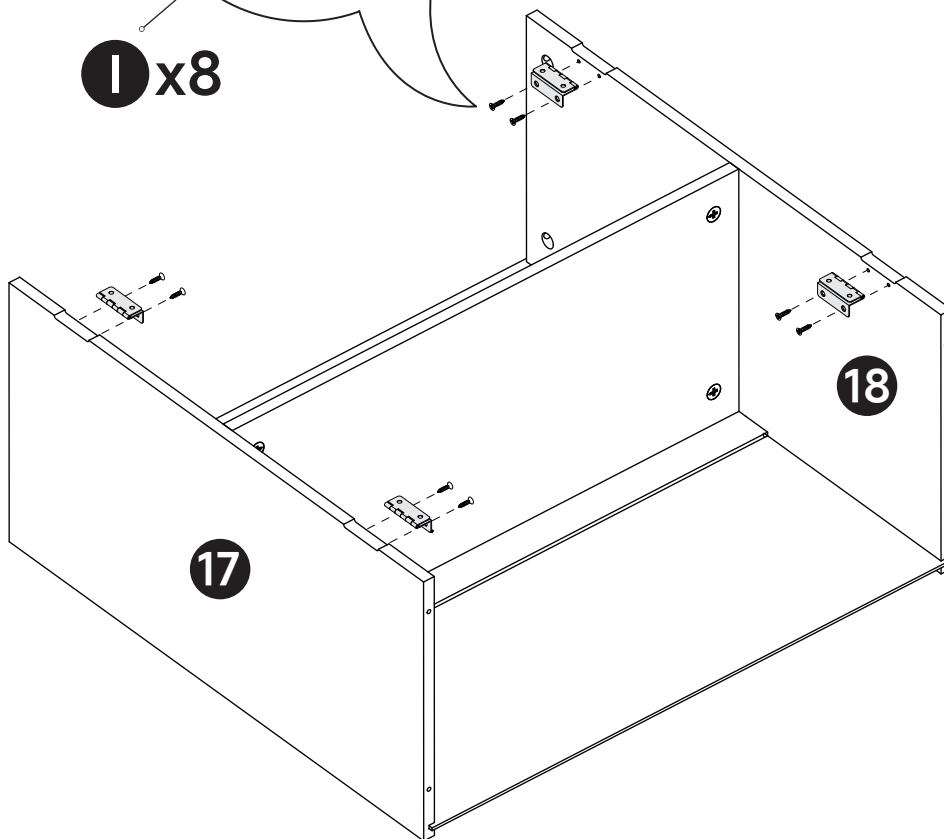

STEP 12

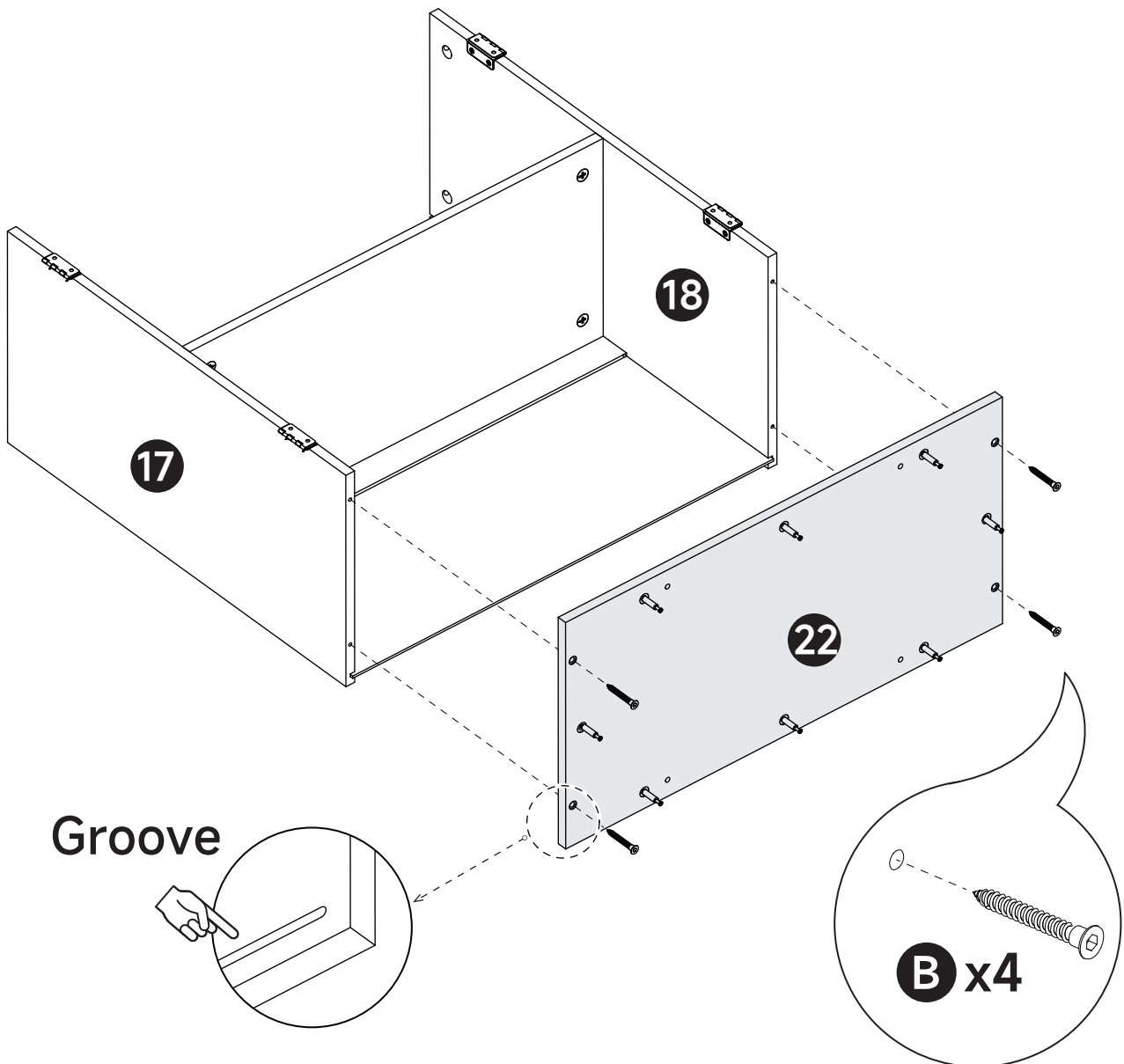

STEP 13

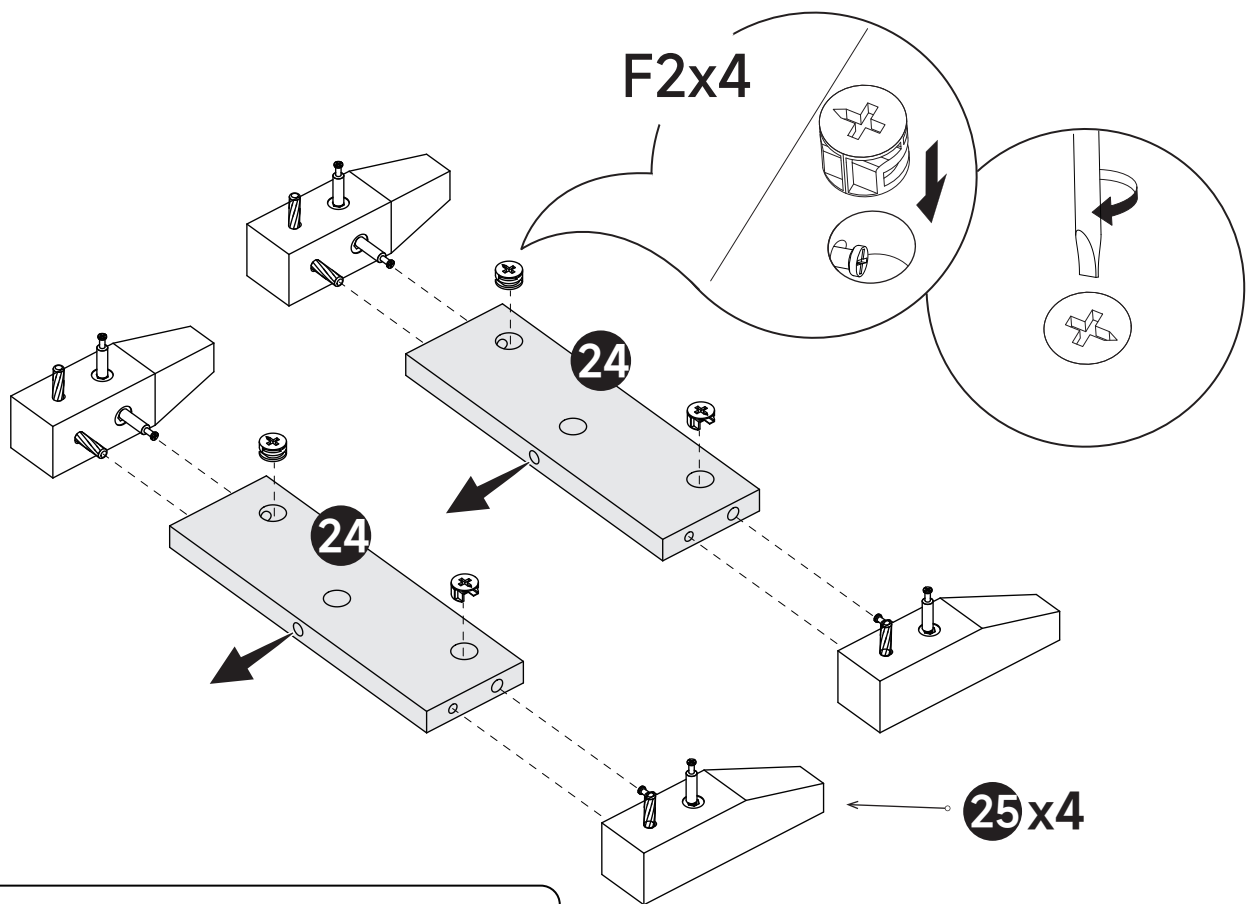
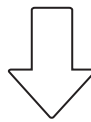
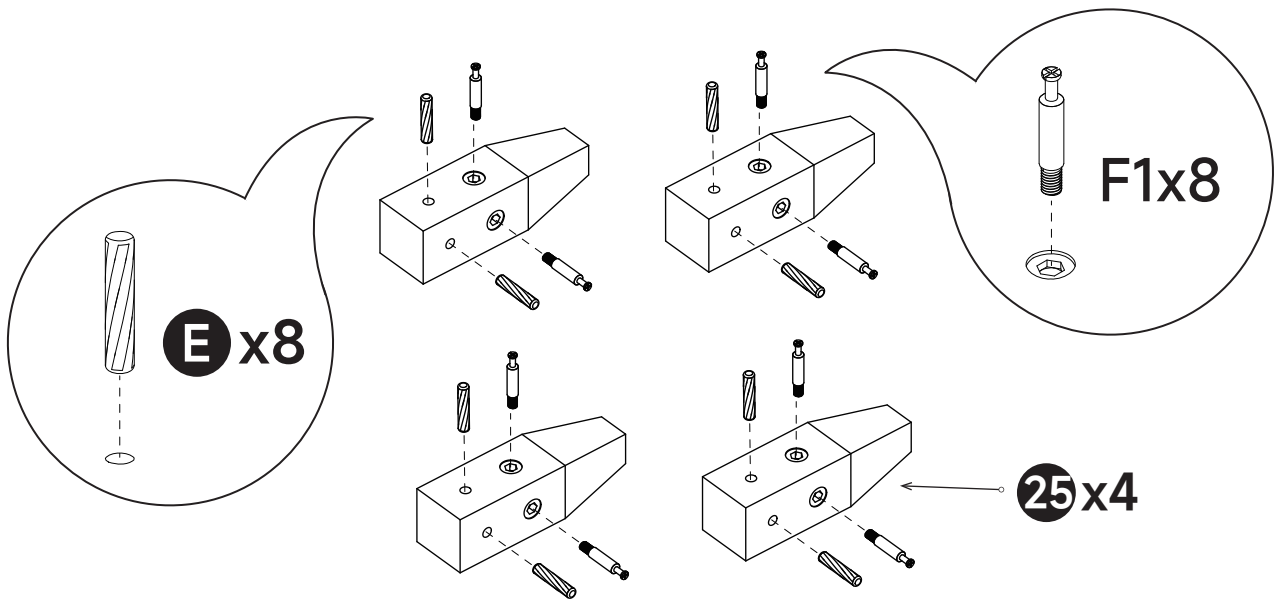

 Note the direction of the holes.

STEP 14

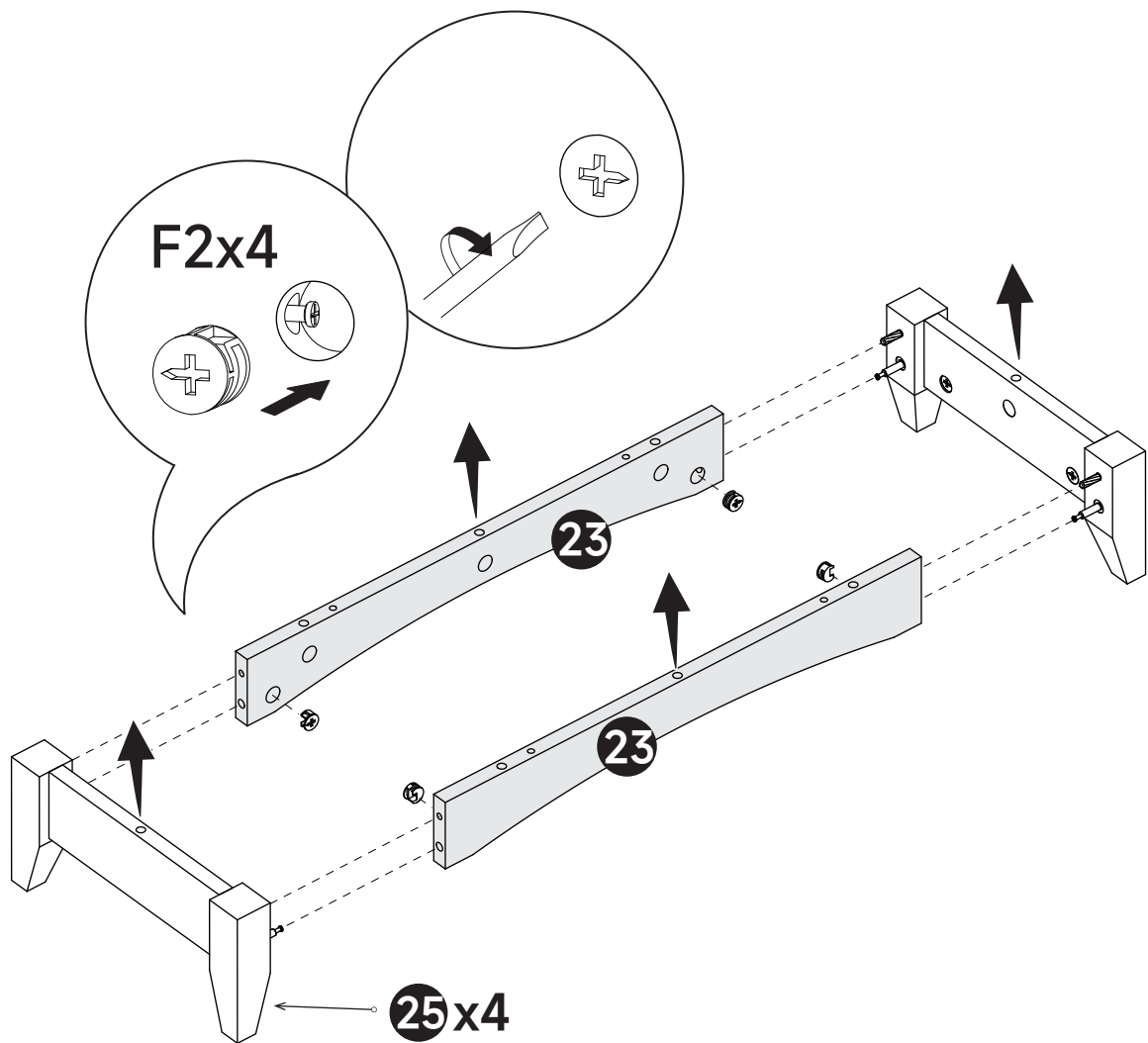

 Note the direction of the holes.

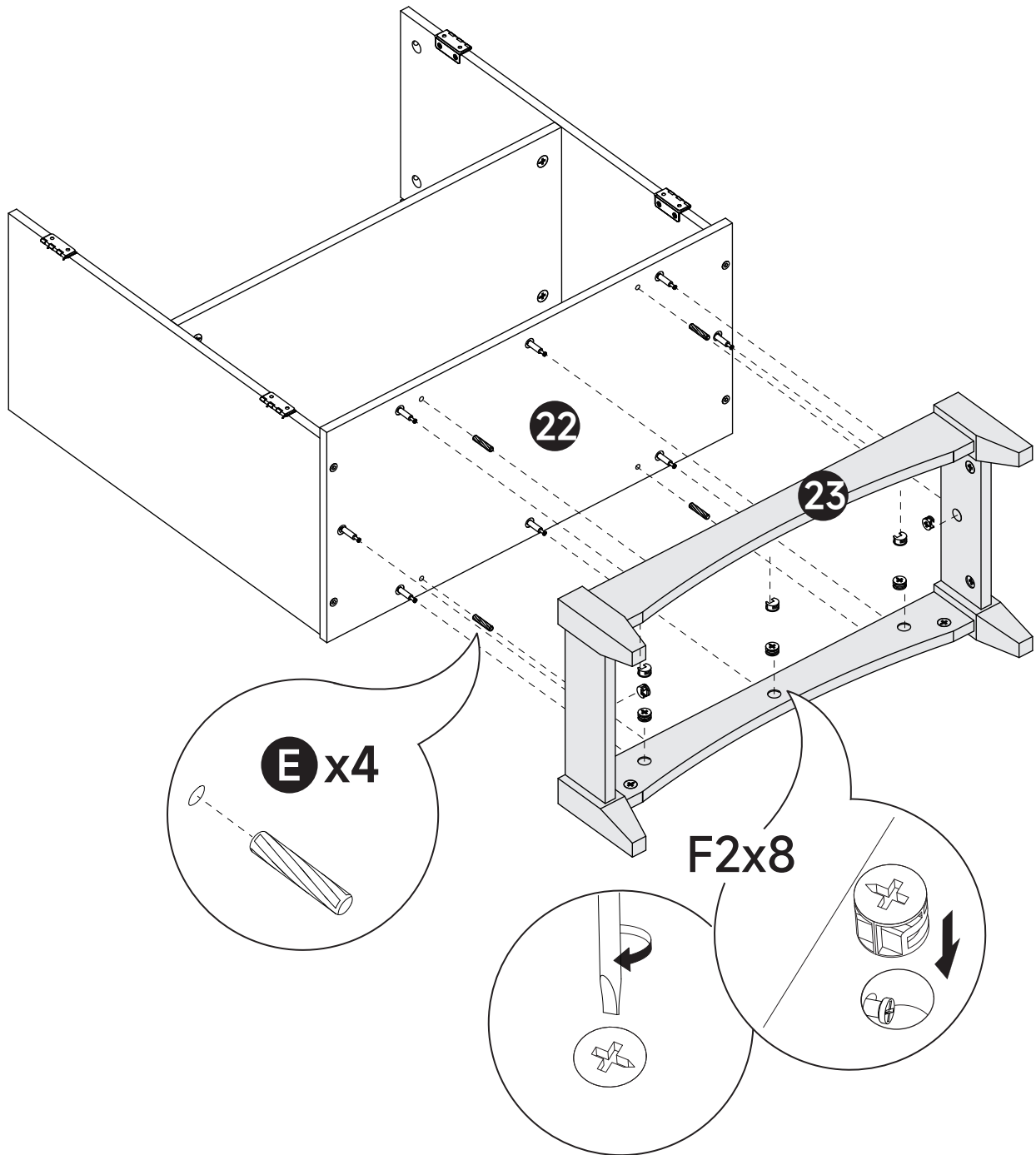

STEP 16

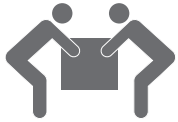

WARNING

Some steps are more easily handled with two adults.

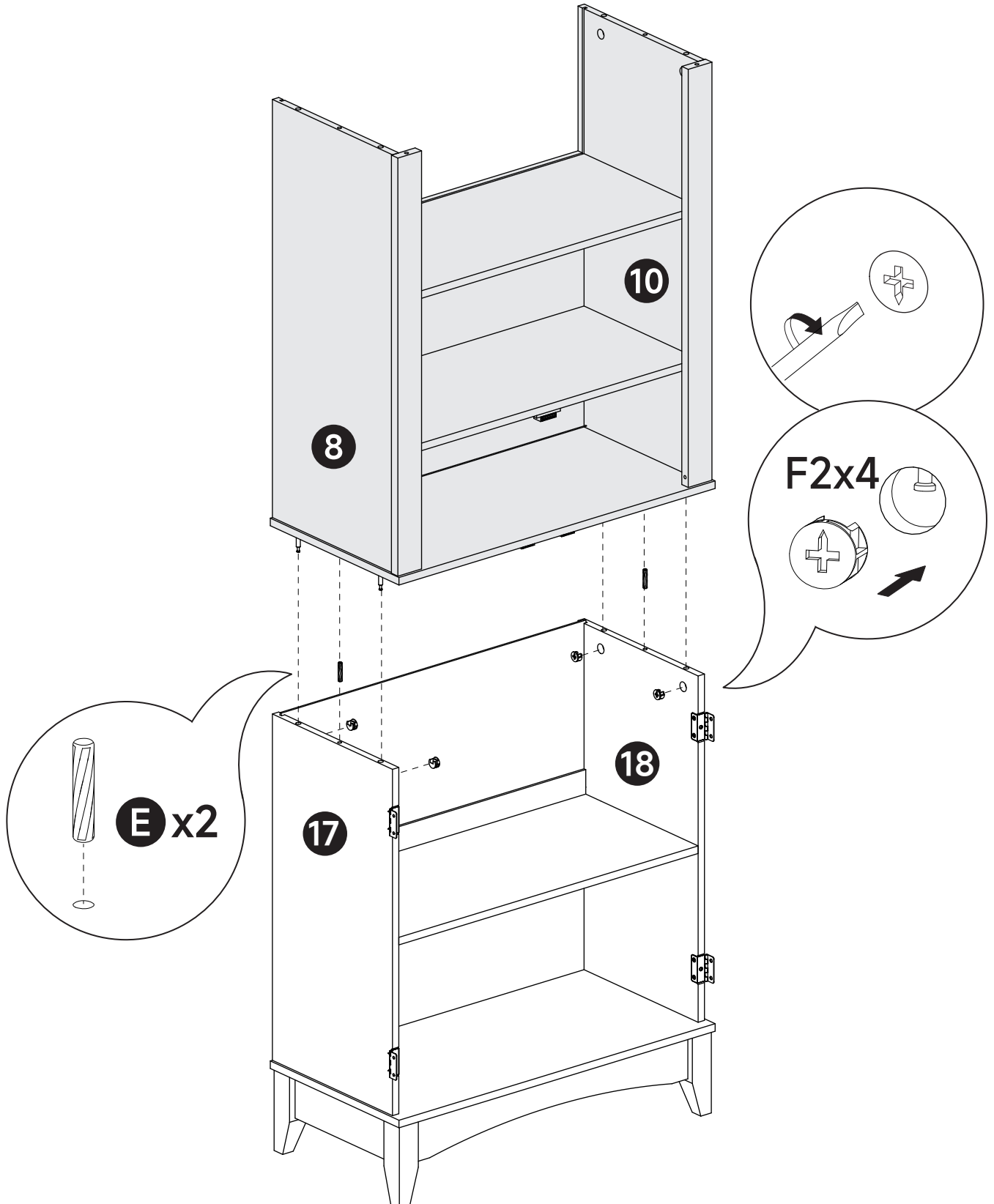

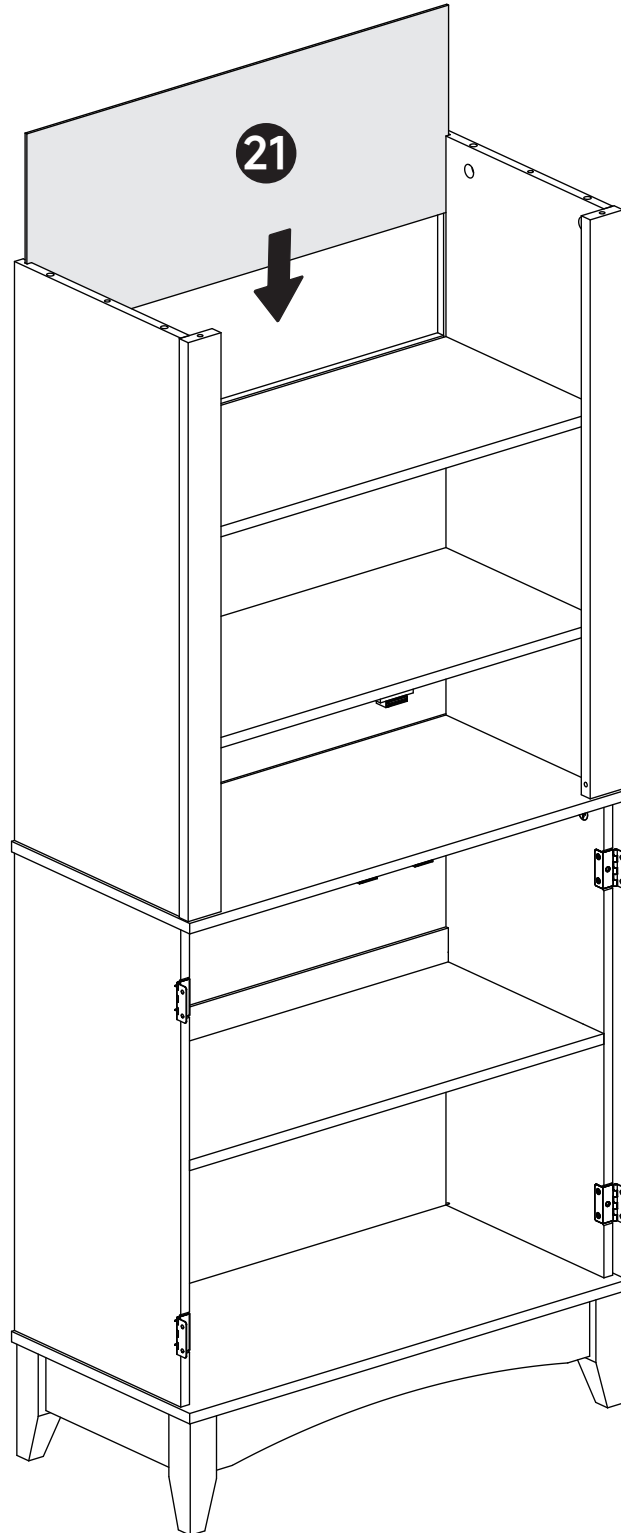

STEP 18

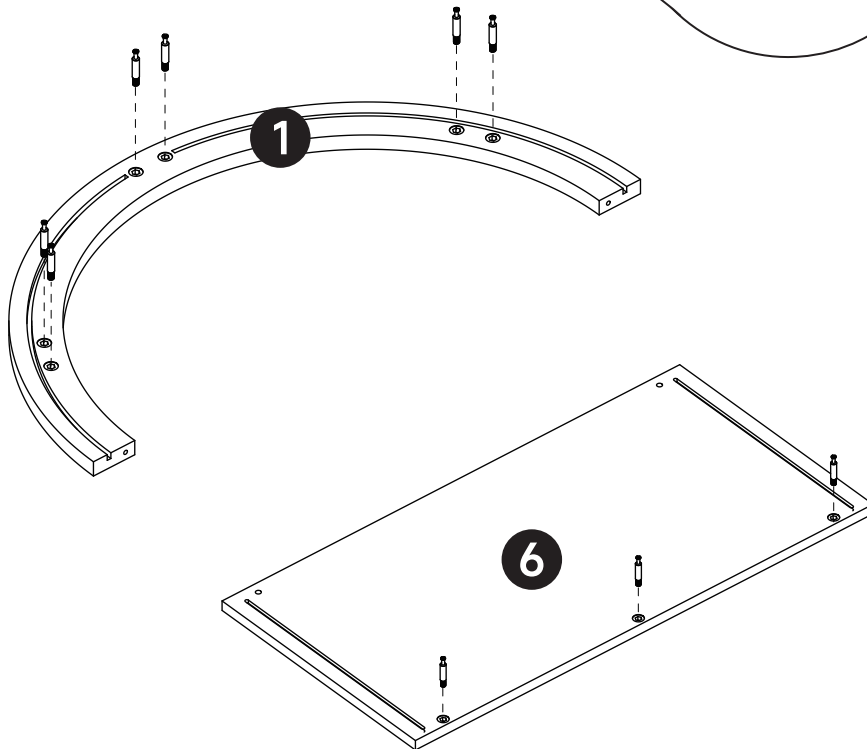
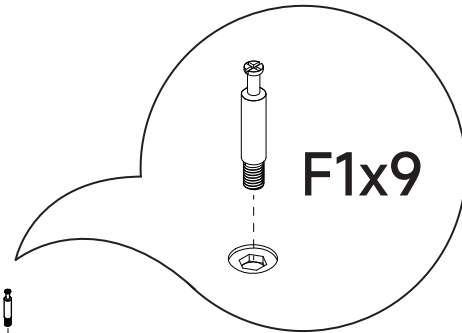
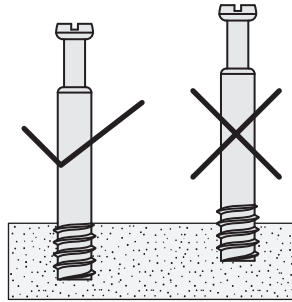
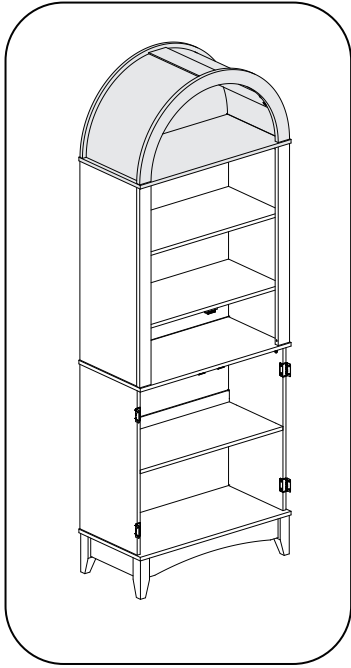

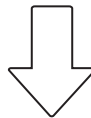
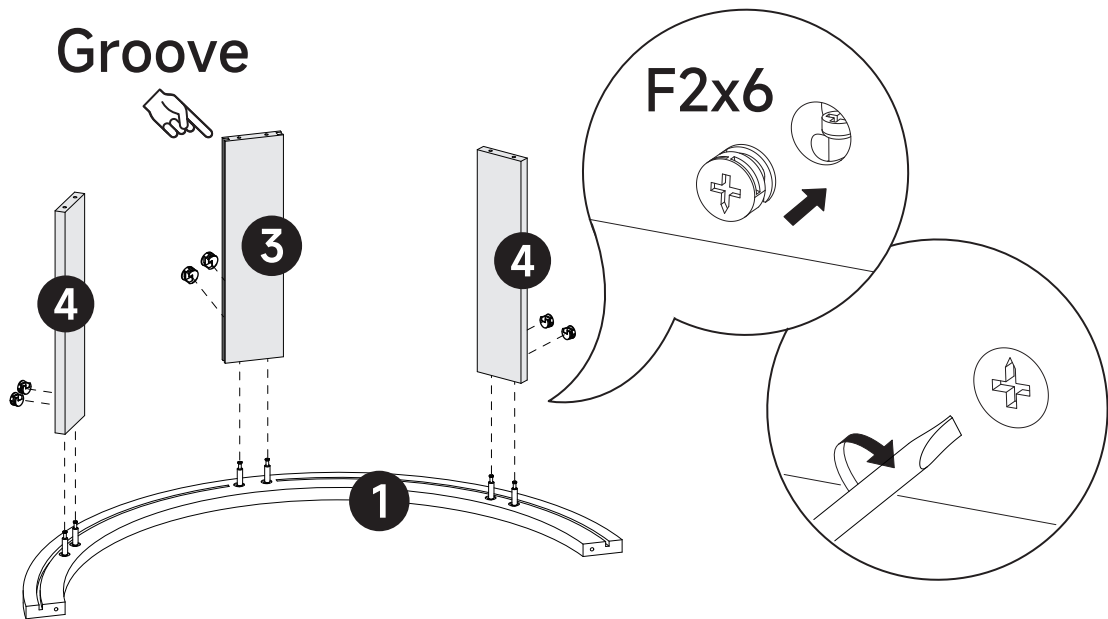

 Note the direction of the holes.

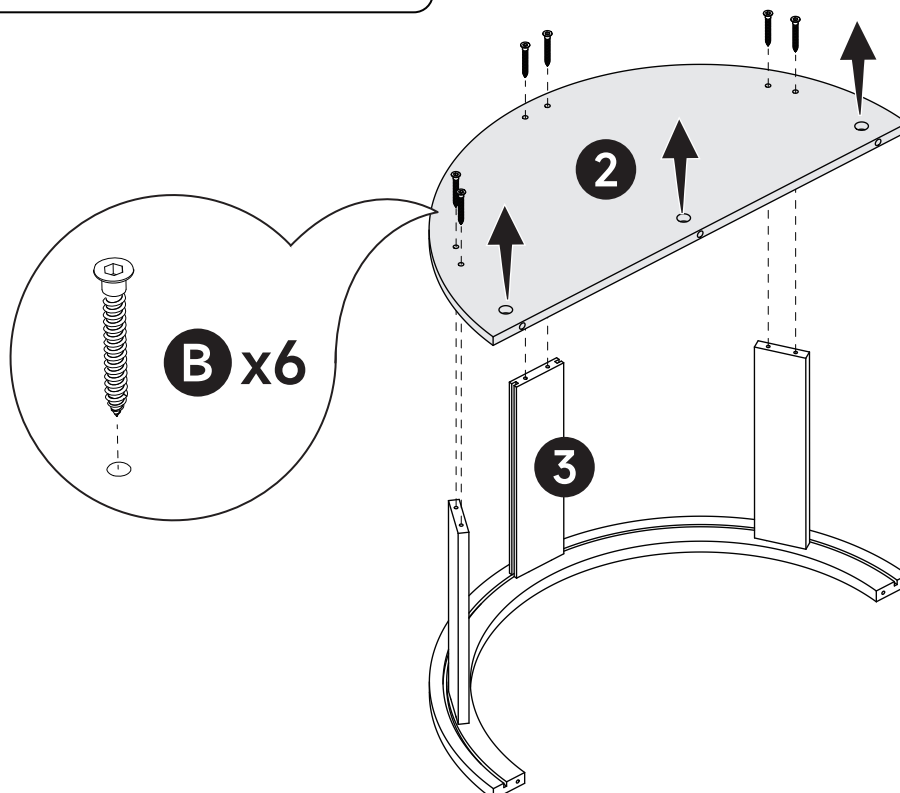

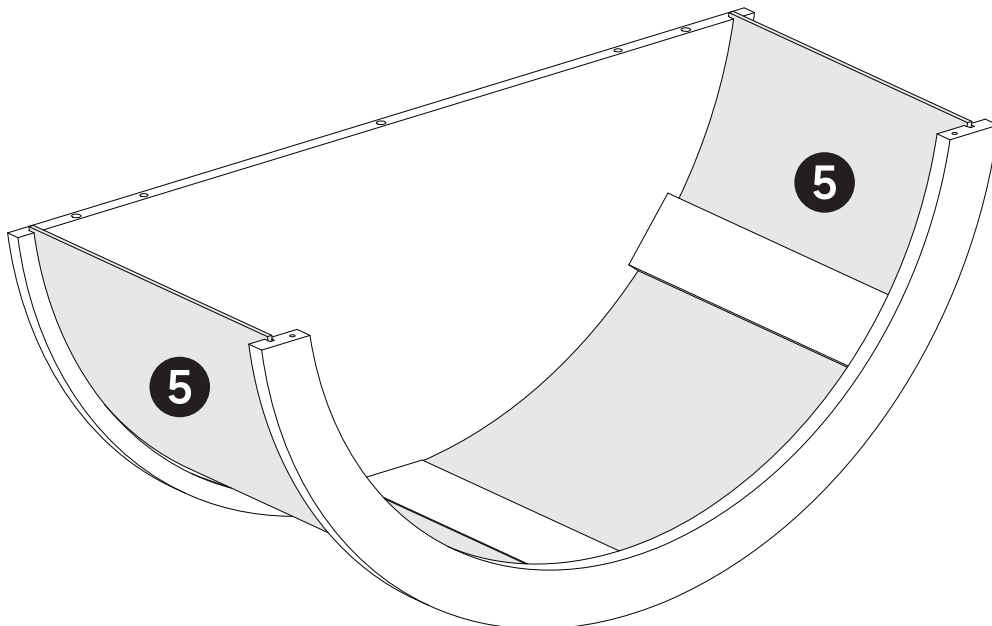
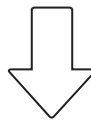
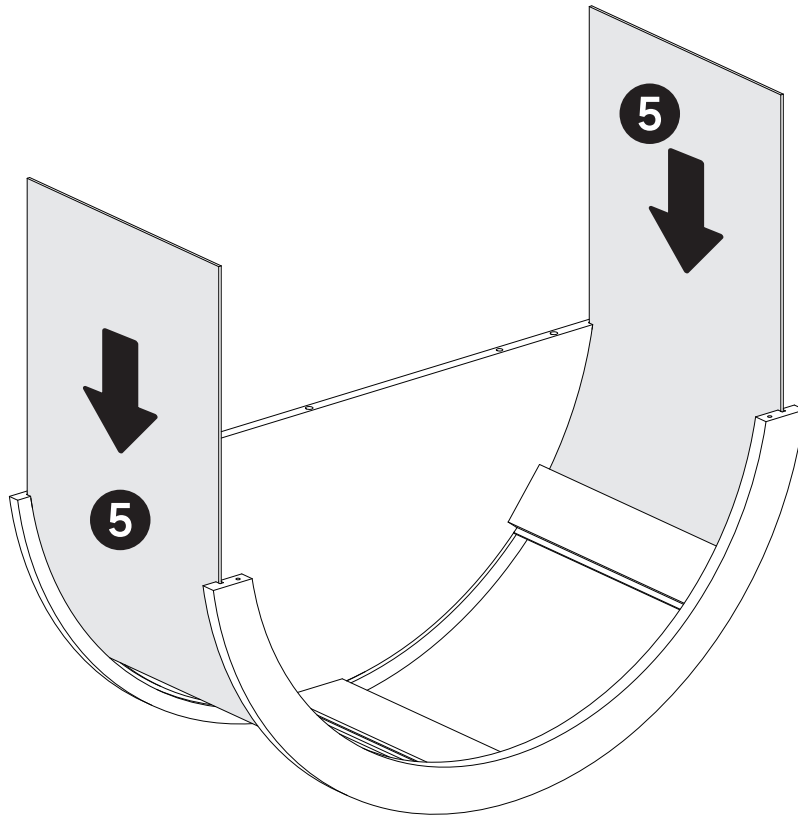

STEP 21

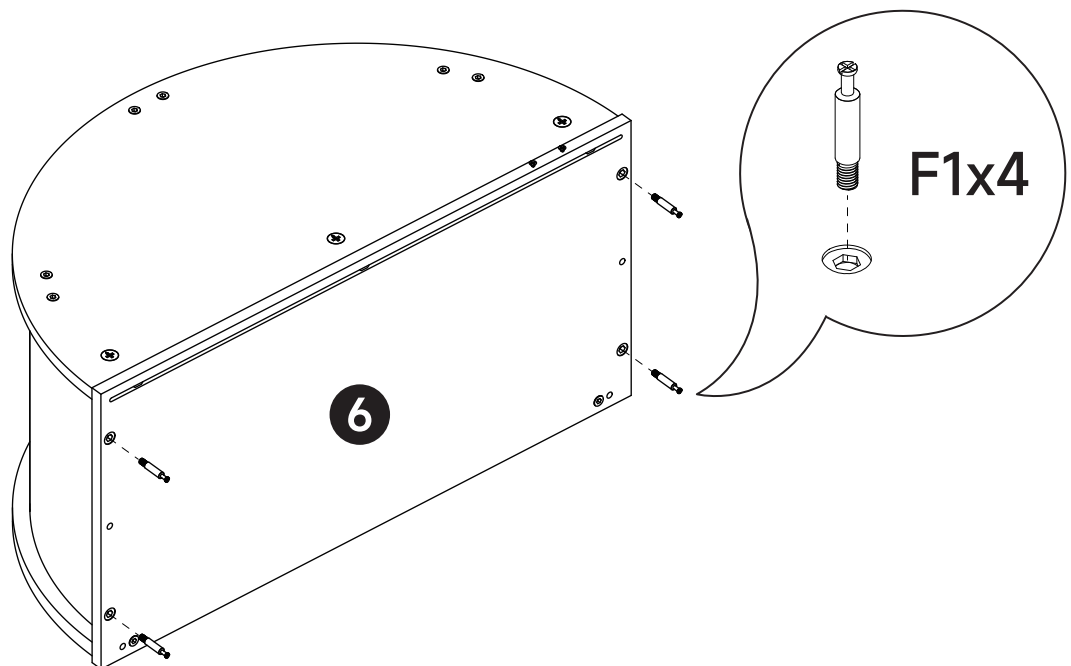
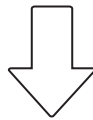
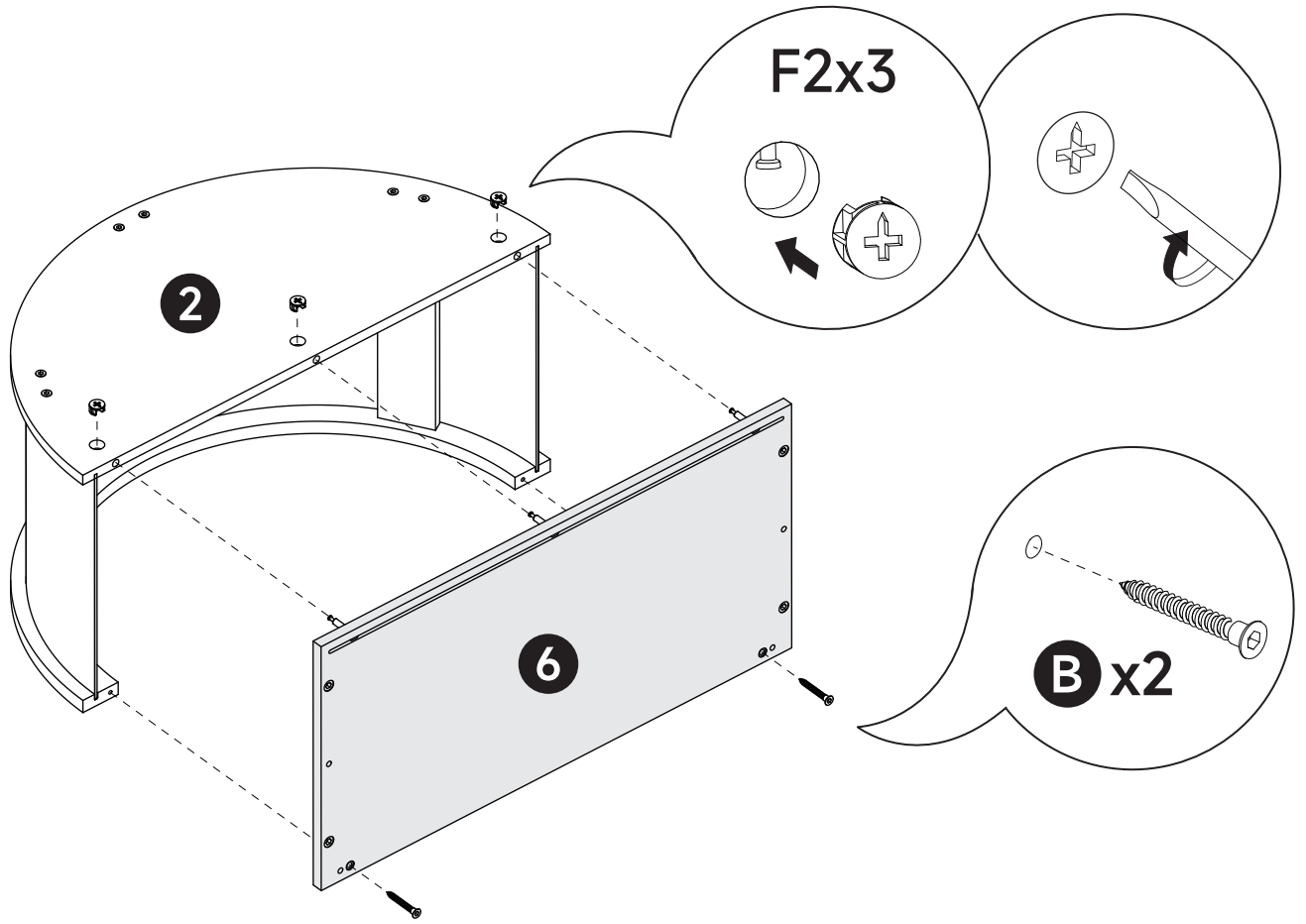

STEP 22



WARNING

Some steps are more easily handled with two adults.

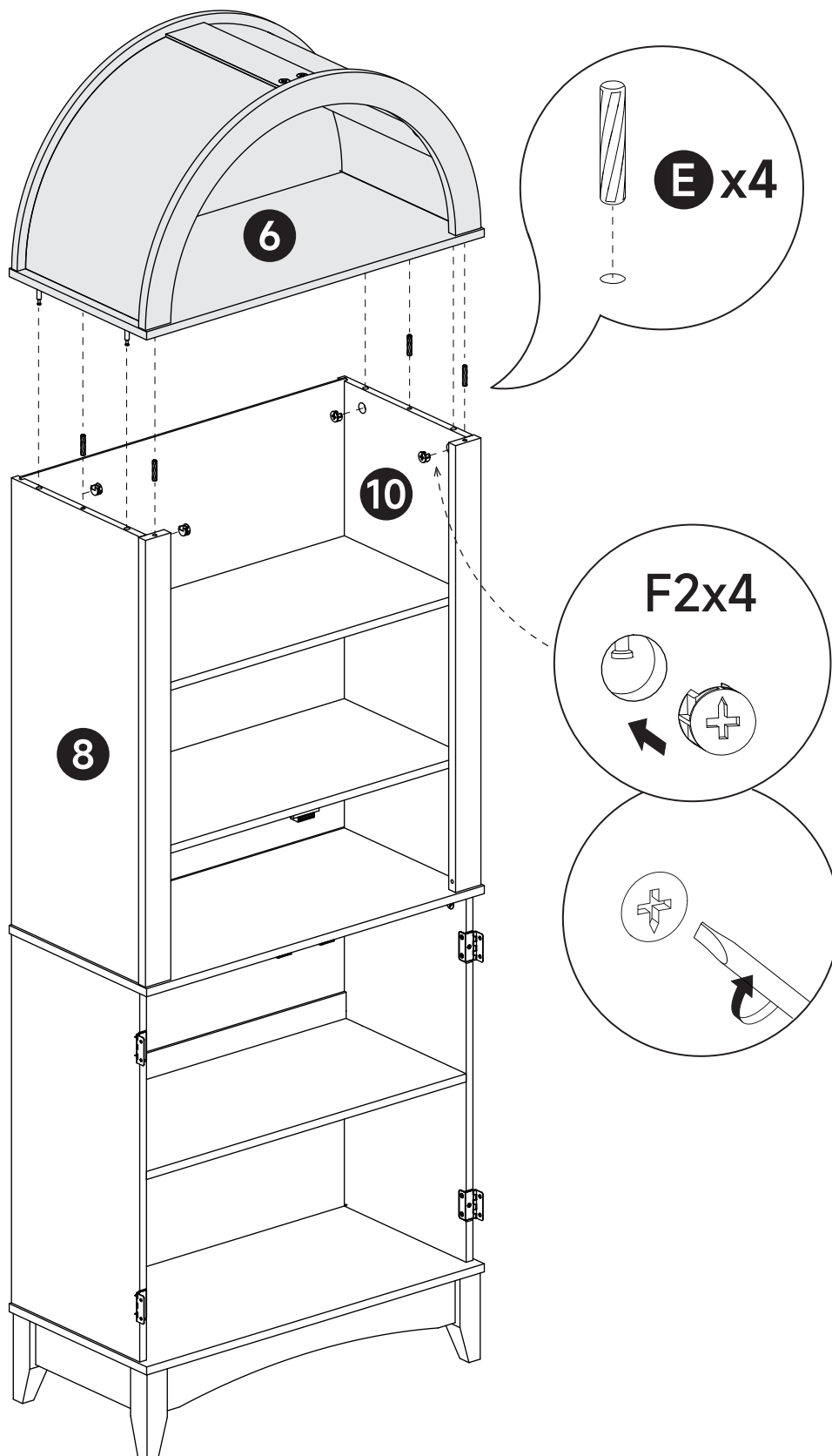

STEP 23



To ensure the structural stability during use, be sure to install the back insert buckles as shown.

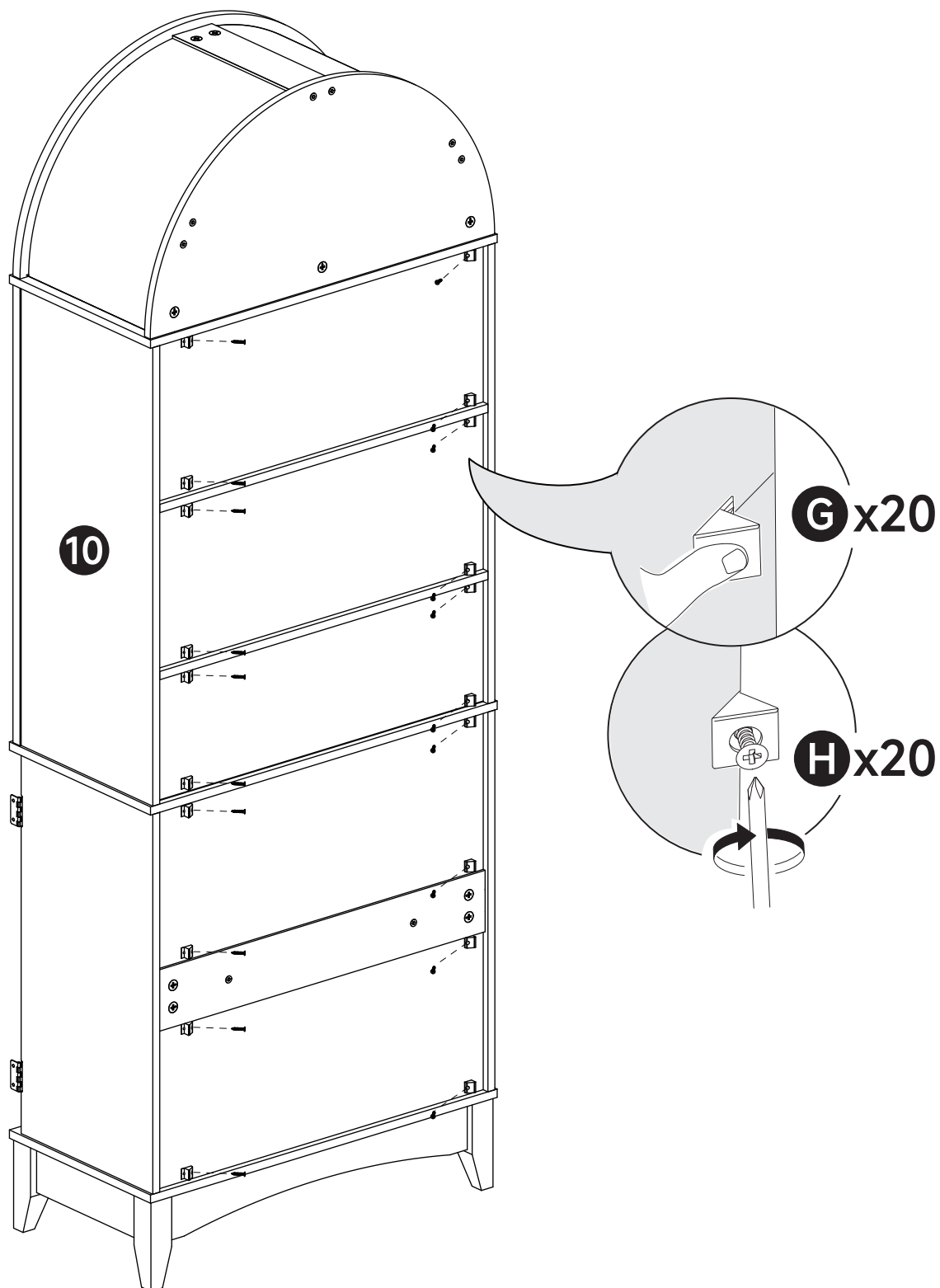

STEP 24

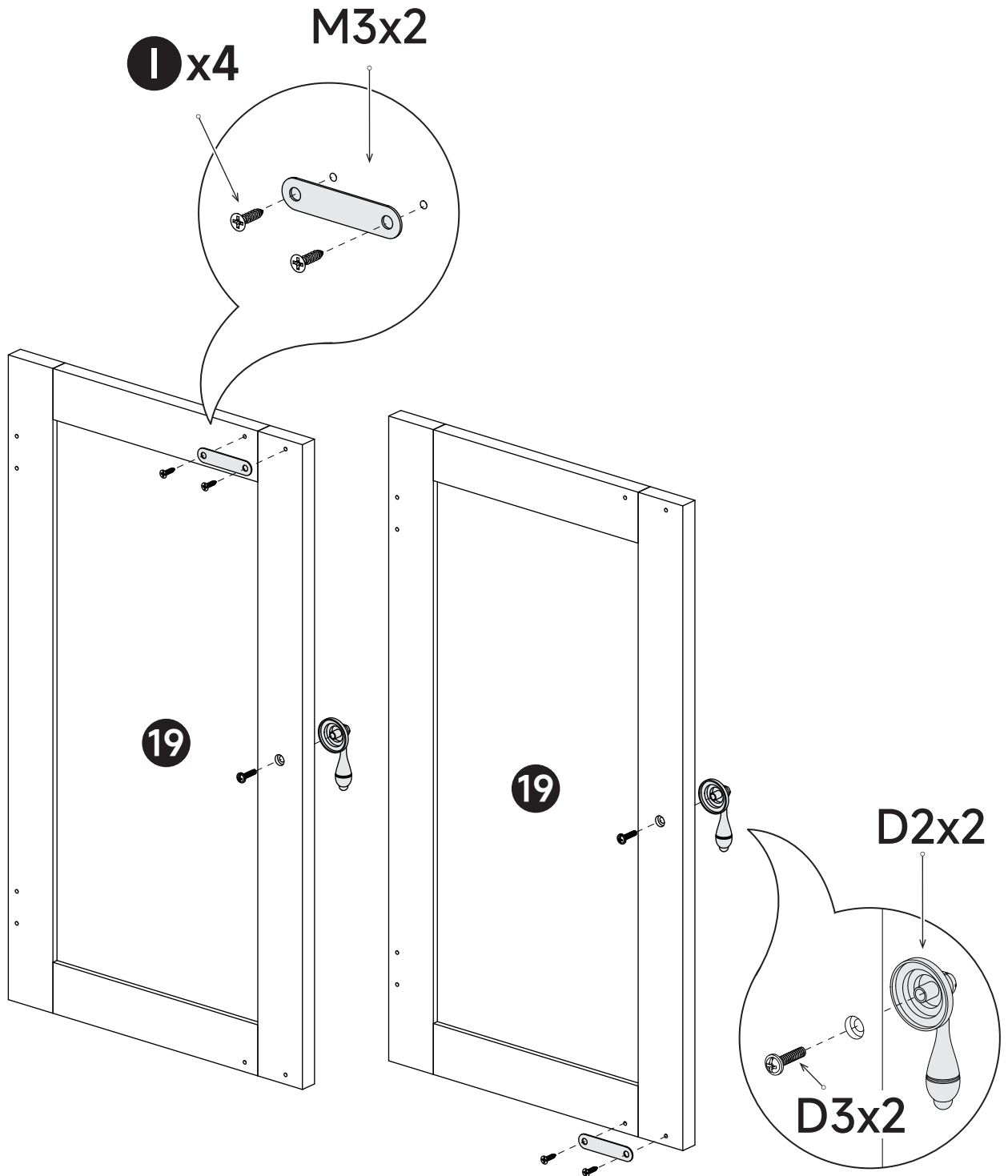

STEP 25

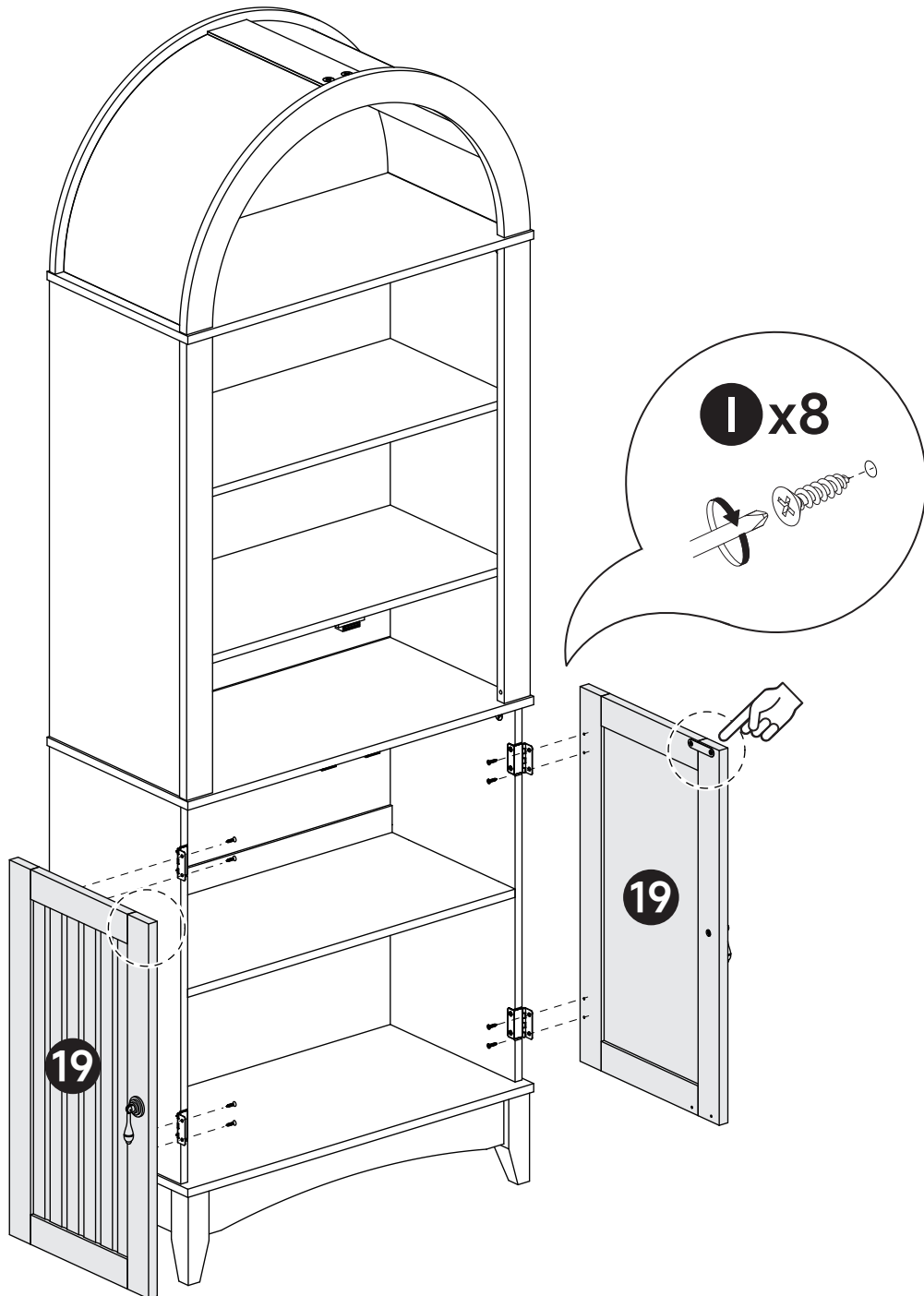

STEP 26

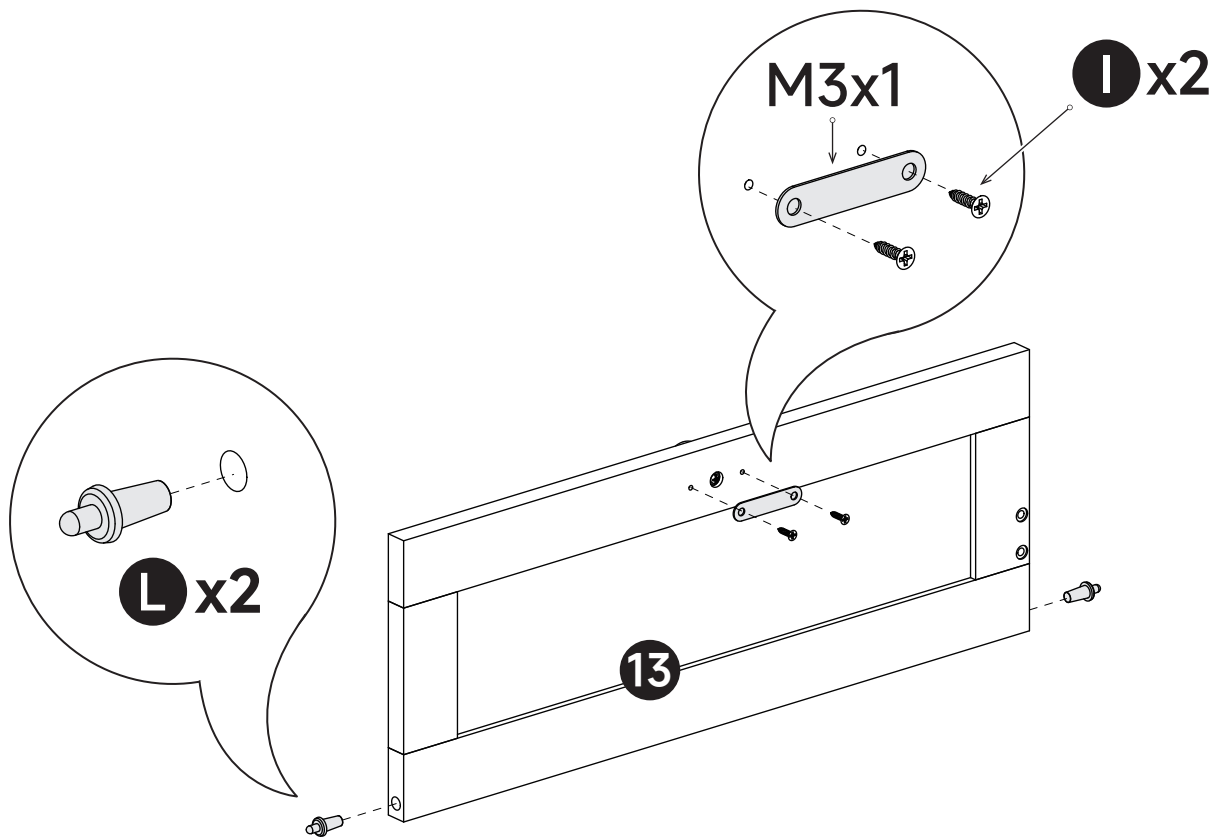
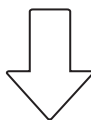
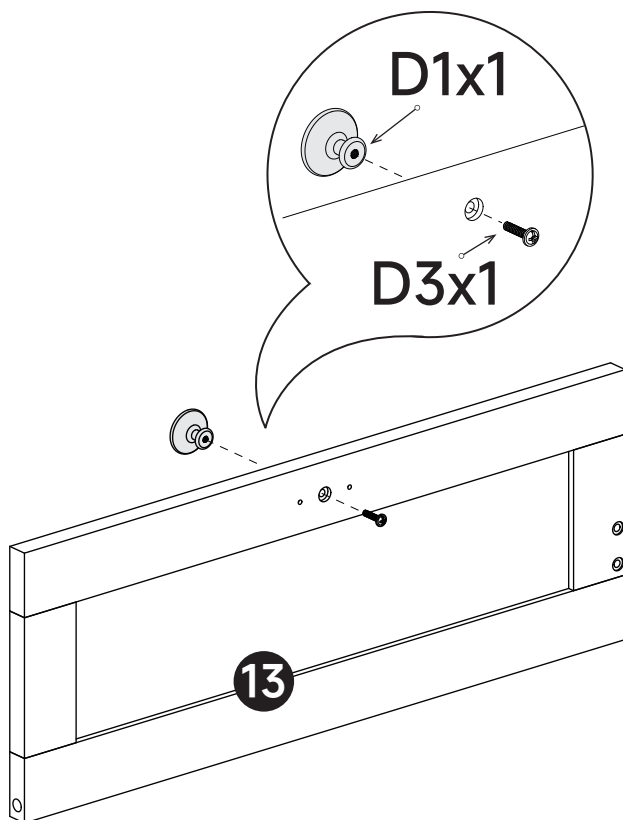

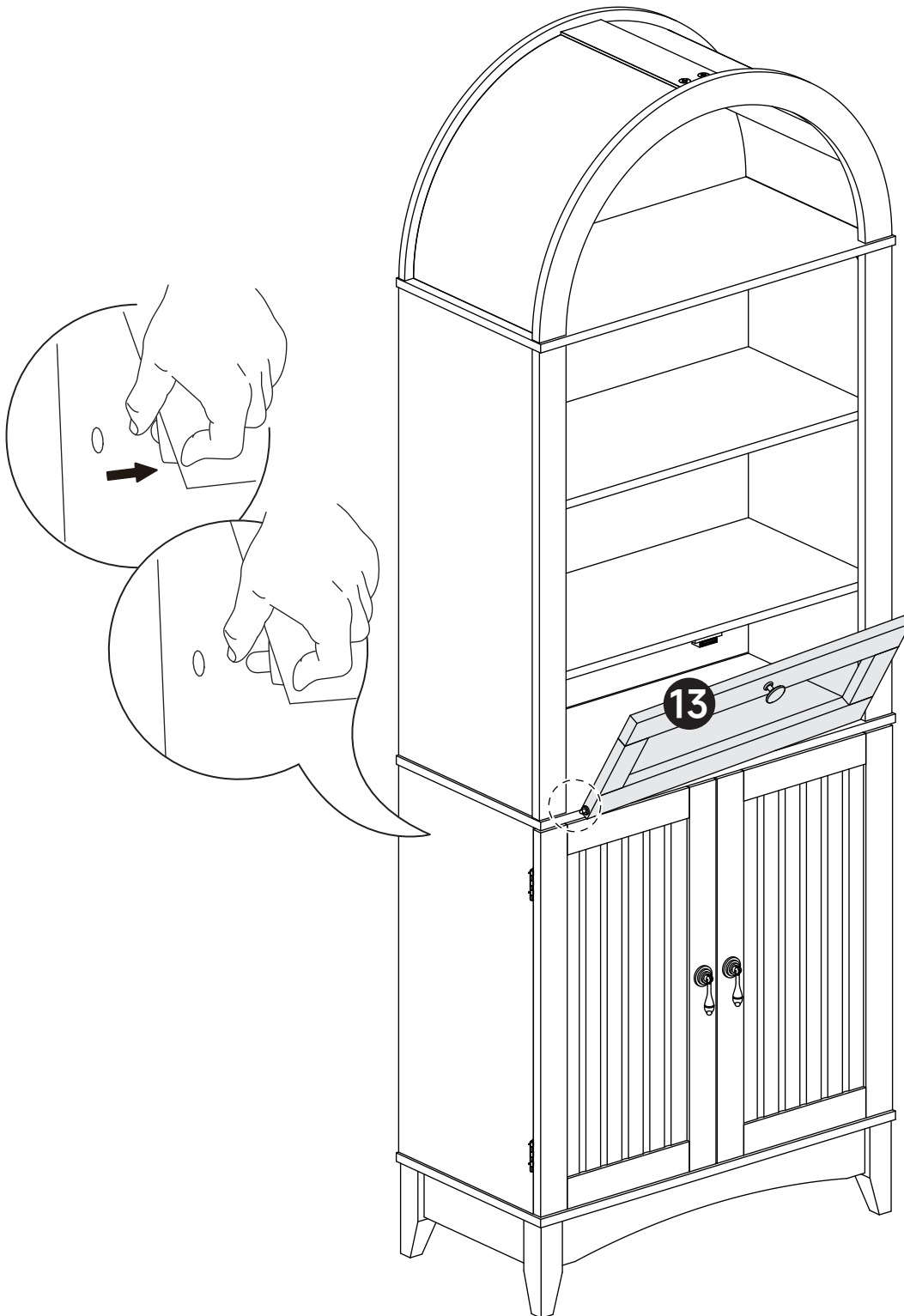

STEP 28

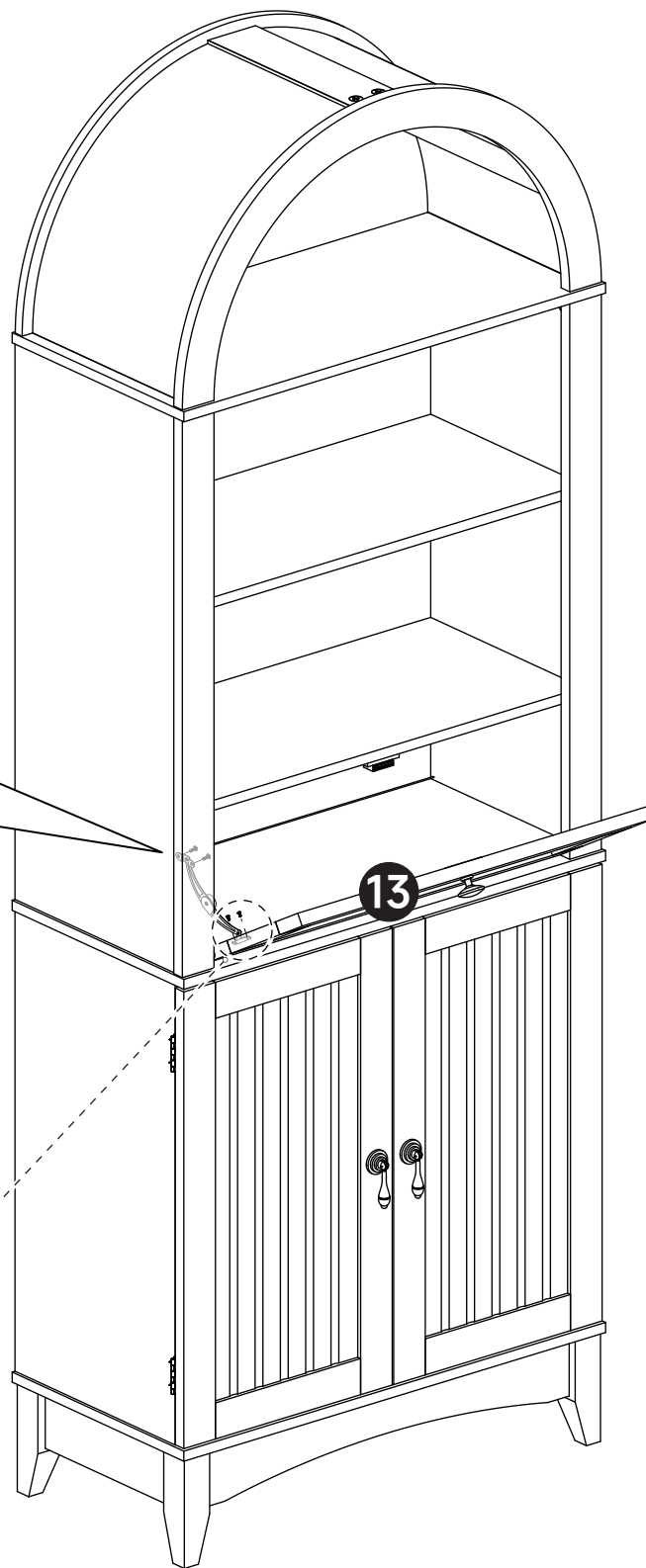
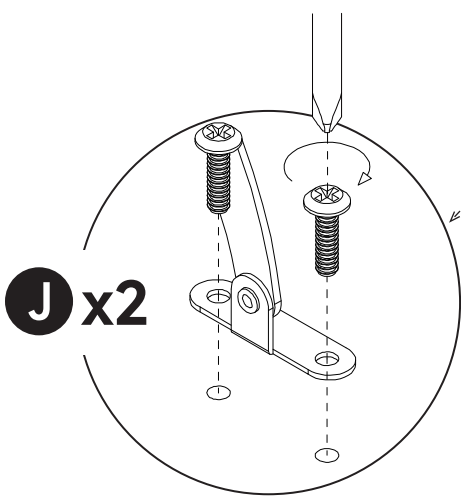
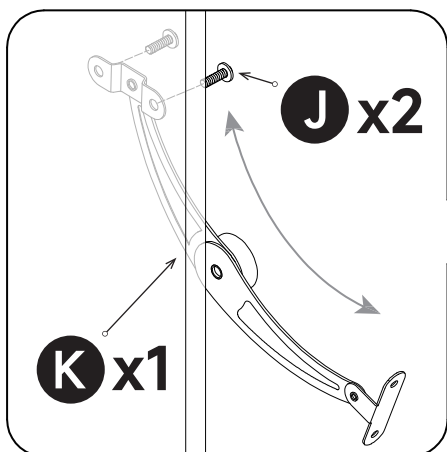
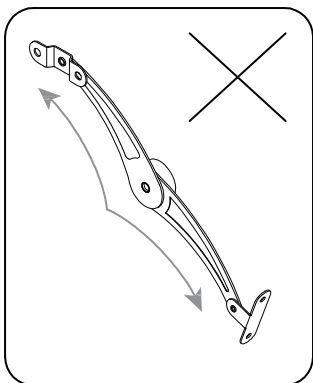

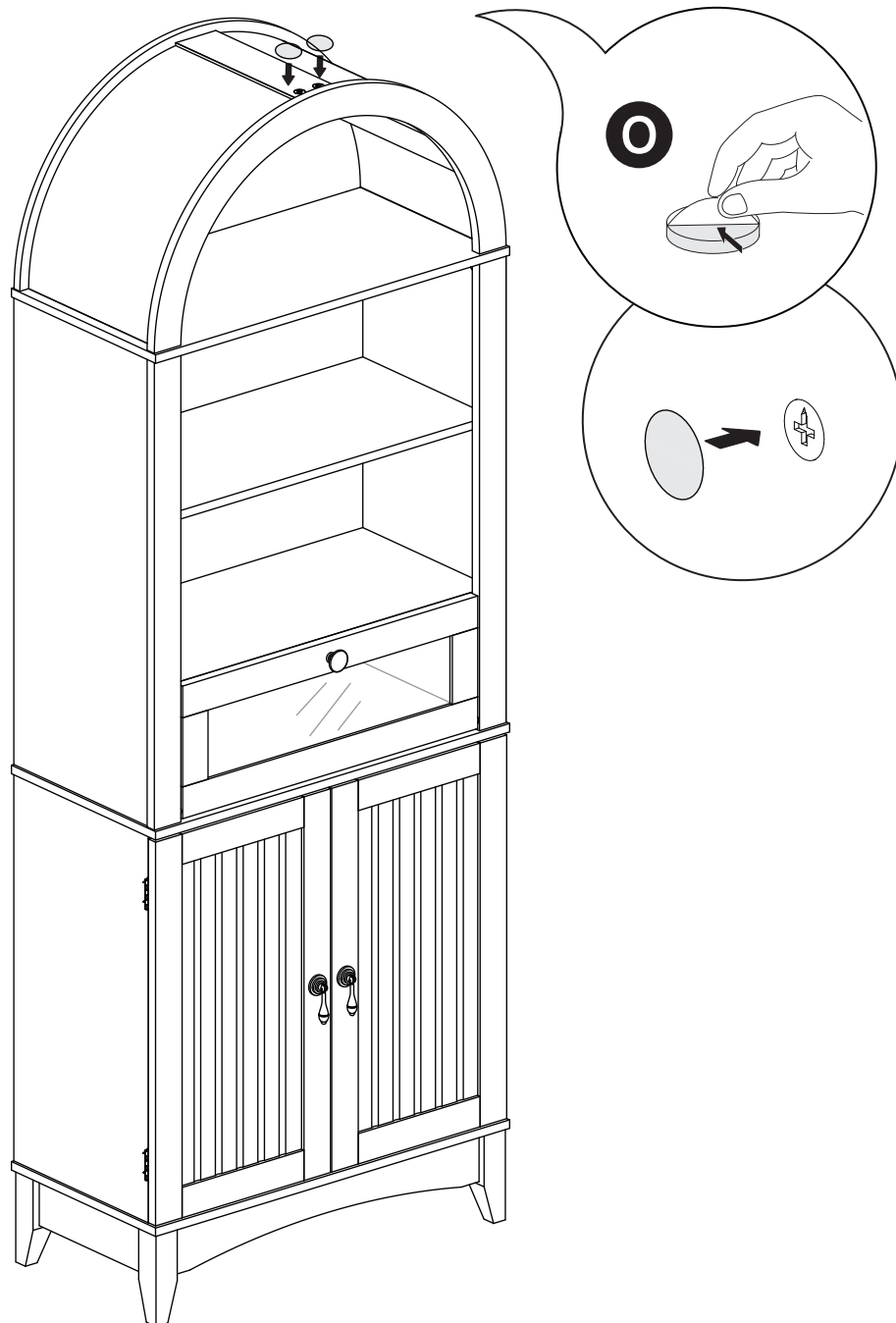

Sticker

- Apply screw stickers over exposed screw holes for aesthetics.

STEP 30



- This product is equipped with two types of the expansion screws, please use the correct accessories according to the wall constructions.

Method 1: For solid or concrete wall.

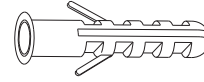

- ① Chose your desired location on the wall, have your friend hold the product in place and use a pencil to mark where the anchor will go.

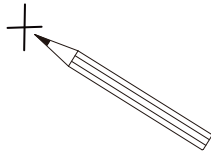

- ② Please pre-drill holes on the wall with a drill bit that's larger than the wall anchors.

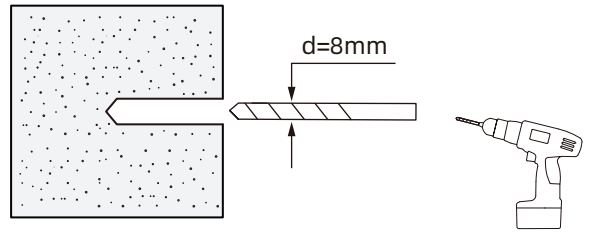

- ③ Push the wall anchor gently into the pre-drilled hole.

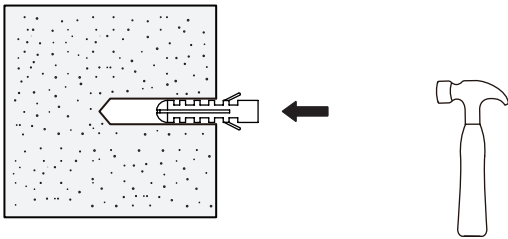

- ④ Drive the screws with a screwdriver into the wall anchor to complete the installation.

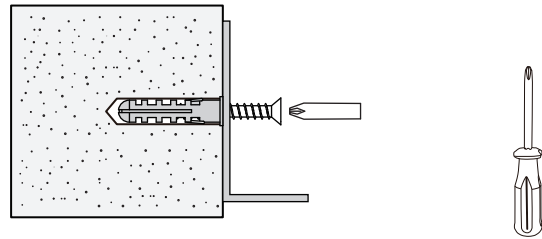

Method 2: For hollow wall.

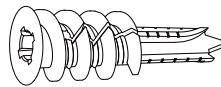

- ① Using a phillips screwdriver or drill bit, Press the anchor into your wall.

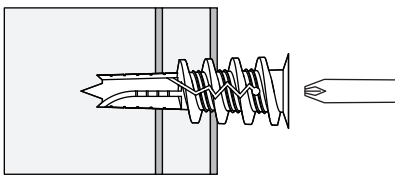

- ② Apply moderate pressure and screw the anchor into the wall until it's flush with the drywall.

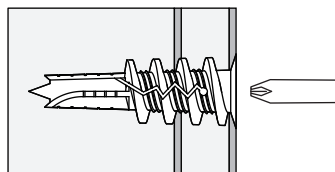

- ③ Insert a screw into the item to be hung then drive that screw into the anchor.

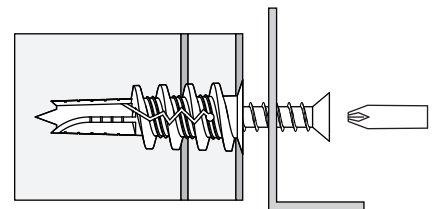

STEP 31



- Check for hidden pipes and cables before drilling.

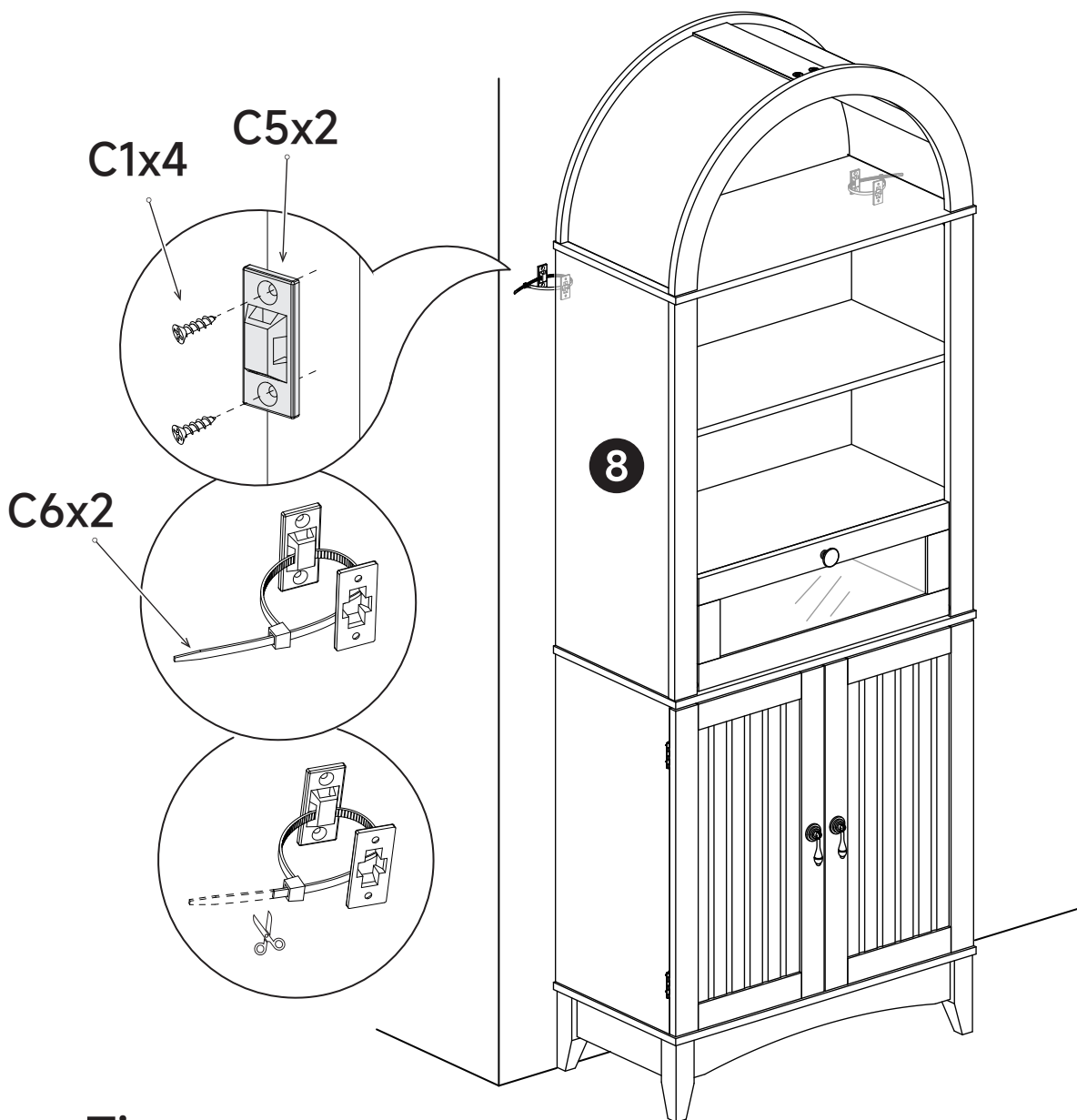
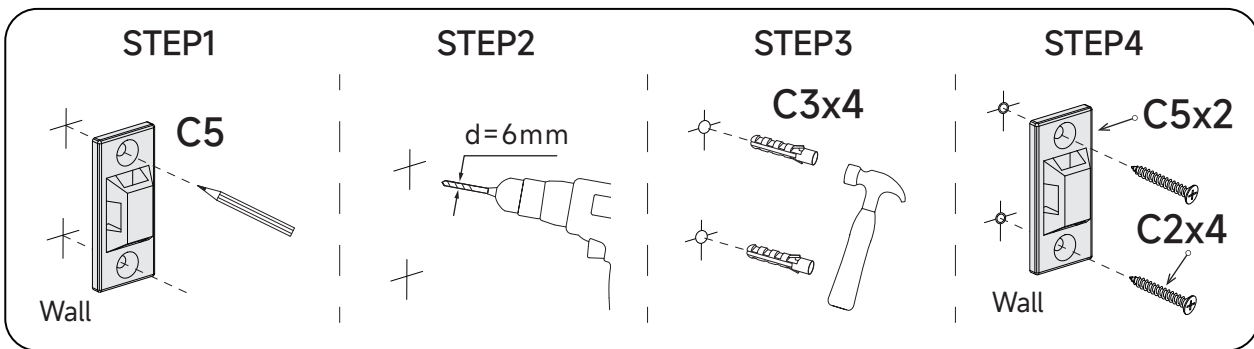

• Tip •

- Set the hairdryer to low heat and hold it a few inches away and move it around to evenly heat the sticker. Once the adhesive is softened, gently peel the sticker off and address any residue with a damp cloth, rubbing alcohol or adhesive remover.