

# TABLES

## ASSEMBLY GUIDE

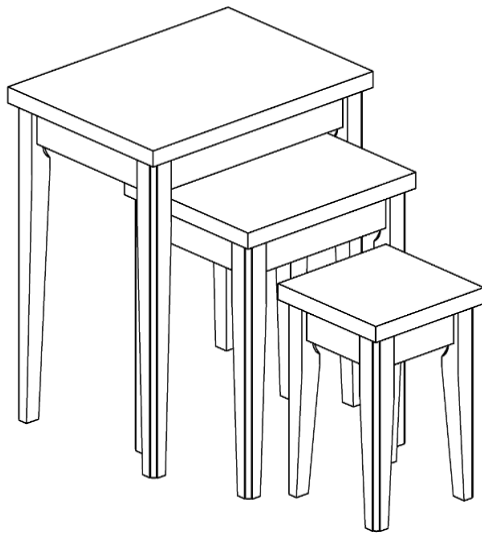

**Important - Please read these instructions fully before starting assembly**



**SAFETY AND  
CARE ADVICE**



**NO POWER TOOLS**

**SAFETY AND CARE ADVICE**

- Check you have all the components and tools listed.
- Remove all fittings from the plastic bags and separate them into their groups.
- We do not recommend the use of power drills/drivers for inserting screws, as this could damage the unit. Only use hand screwdrivers and Allen keys.
- Keep children and animals away from the work area, small parts could cause choking if swallowed.
- Make sure you have enough space to layout the parts before starting.
- Assemble the item as close to its final position (in the same room) as possible.
- Do not overtighten the nuts to avoid causing damage to the threads.
- Only clean using a damp cloth and mild detergent, do not use bleach or abrasive cleaners.
- From time to time check that there are no loose screws on this unit
- This product should not be discarded with household waste. Take to your local authority waste disposal centre

## IMPORTANT INFORMATION



30 MINUTE  
BUILD



TWO  
PERSON







MAXIMUM  
CAPACITY  
20KG, 20KG, 10KG

PLEASE CHECK CAREFULLY AND MAKE SURE YOU HAVE ALL FITTINGS AND TOOLS LISTED BELOW BEFORE YOU START.

### LIST OF PARTS

| No | Description      | Qty   |
|----|------------------|-------|
| 1  | Table Top Large  | 1 PC  |
| 2  | Table Top Medium | 1 PC  |
| 3  | Table Top Small  | 1 PC  |
| 4  | Table Leg Long   | 4 PCS |
| 5  | Table Leg Medium | 4 PCS |
| 6  | Table Leg Short  | 4 PCS |

### HARDWARE LIST

| No | Description   | Qty    |
|----|---|--------|
| A  | JCBC BOLT      | 24 PCS |
| B  | Spring Washer  | 24 PCS |
| C  | Flat Washer    | 24 PCS |
| D  | Allen Key      | 1 PC   |

**NOTE:** The quantities above are the correct amount to complete the assembly. In some cases more fittings may be supplied than are required.

## STEP 1

Use a clean, flat, soft surface to avoid any bumps or scratches.

For large table, place table top [1] face down on your flat surface. Attach 4x table legs [4] - align the pre-drilled holes and connect using 2x flat washers [C] + 2x spring washers [B] + 2x bolts [A] per leg - 8 in total.

Tighten with Allen key [D] but avoid over-tightening.

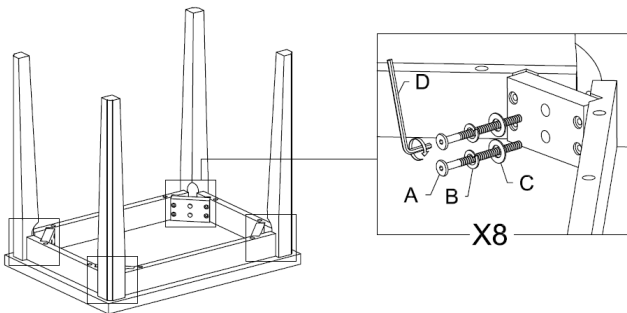

## STEP 2

Carefully flip your table upright onto its legs. Check for stability. Your new table is now ready to use. Repeat assembly process for the medium and small table - make sure to attach the correct legs to each table.

Legs [5] go with the medium table top [2].

Legs [6] go with the small table top [3]

