

# Montageanleitung | Instructions de montage Assembly Instructions | Instrucciones de montaje

SKU NUMBER  
N601P343828  
N601P343829  
N601P343830  
N601P343831

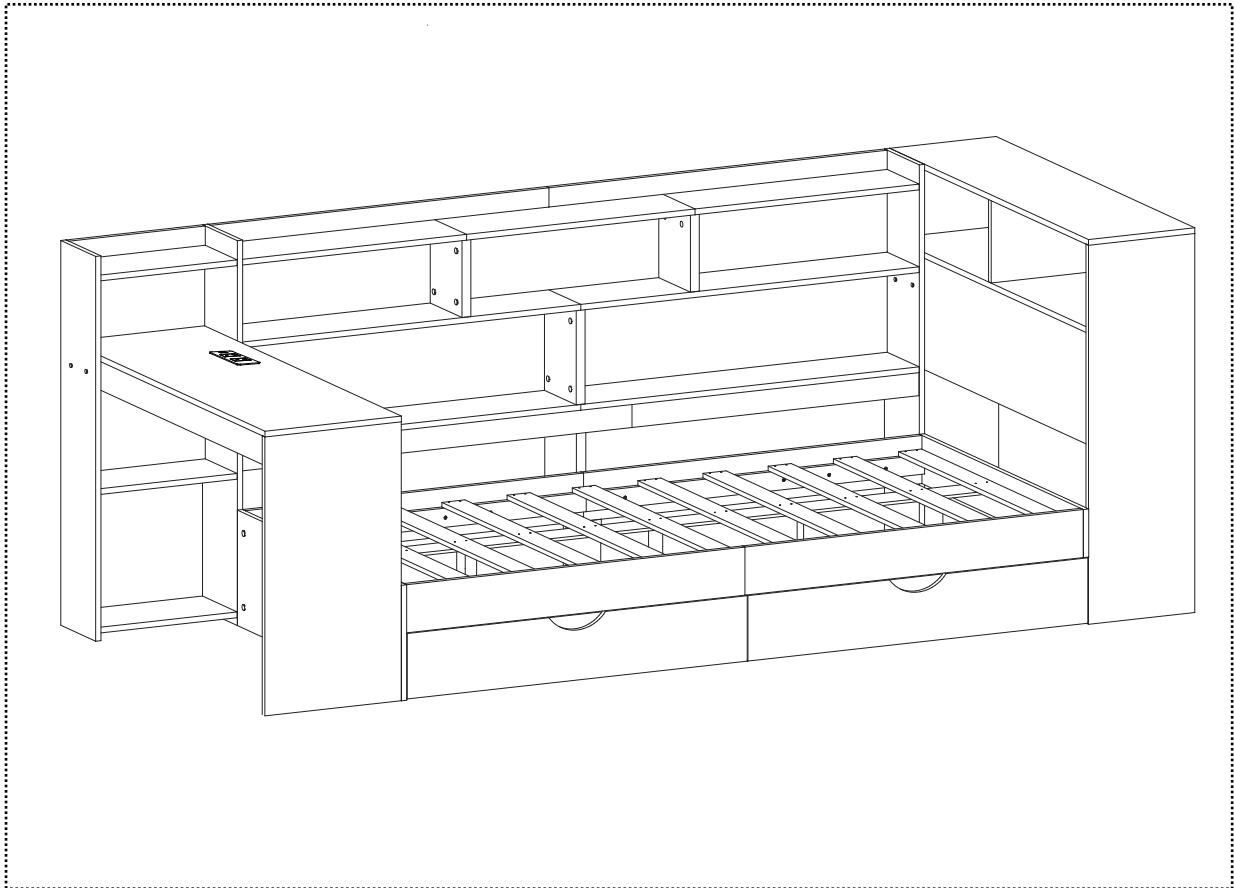

UK  
CA



**GB** This set comes in 4 boxes. If you do not receive a full set of 4 boxes, please contact our customer service.

**DE** Dieses Set wird in 4 Schachteln geliefert. Wenn Sie nicht ein komplettes Set von 4 Boxen erhalten, kontaktieren Sie bitte unseren Kundenservice.

**FR** Ce set est livré en 4 boîtes. Si vous ne recevez pas un jeu complet de 4 boîtes, veuillez contacter notre service clientèle.

## 💡 More Tips 💡

1

**English** - Before installation, you can place the parts on a carpet or other soft fabric, in order to avoid damaging your floor.

**Français** - Avant l'installation, vous pouvez placer les pièces sur un tapis ou un autre tissu doux, afin d'éviter d'endommager votre sol.

**Deutsch** - Vor der Installation können Sie die Teile auf einen Teppich oder ein anderes weiches Material legen, um eine Beschädigung Ihres Fußbodens zu vermeiden.

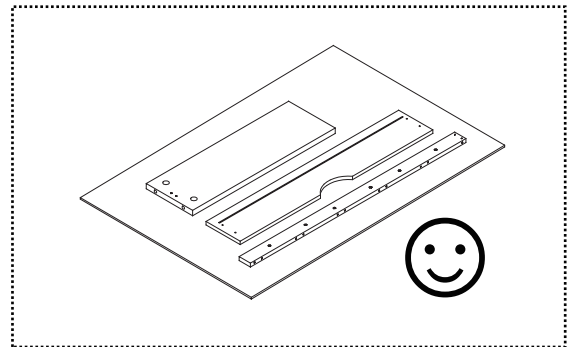
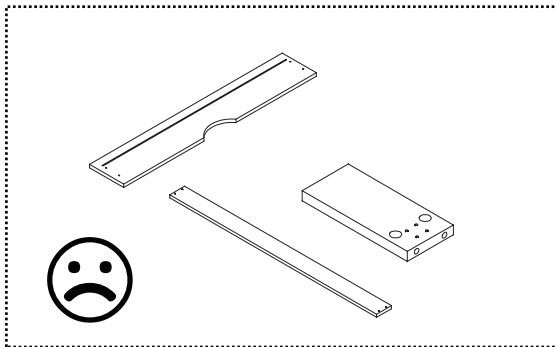

2

**English** - For your and your family's safety, please do not jump on beds, especially with hydraulic structures. When need to move bed, please work with more than one person to lift, not push, to avoid scratching your floor and hurting the stability of the bed.

**Français** - Pour votre sécurité et celle de votre famille, ne sautez pas sur les lits, en particulier sur les structures hydrauliques. Lorsqu'il est nécessaire de déplacer le lit, il est préférable de travailler à plusieurs pour le soulever, et non pour le pousser, afin d'éviter de rayer le sol et de nuire à la stabilité du lit.

**Deutsch** - Zu Ihrer Sicherheit und der Ihrer Familie sollten Sie nicht auf Betten springen, insbesondere bei hydraulischen Konstruktionen. Wenn Sie das Bett bewegen müssen, heben Sie es bitte mit mehreren Personen an und schieben Sie es nicht, um den Boden nicht zu verkratzen und die Stabilität des Bettes nicht zu beeinträchtigen.

**Español** - Para su seguridad y la de su familia, por favor no salte sobre las camas, especialmente con estructuras hidráulicas. Cuando tenga que mover la cama, por favor, trabaje con más de una persona para levantar, no empujar, para evitar rayar su piso y dañar la estabilidad de la cama.

**Italia** - Per la sicurezza vostra e della vostra famiglia, vi preghiamo di non saltare sui letti, soprattutto se dotati di strutture idrauliche. Quando è necessario spostare il letto, si prega di lavorare con più di una persona per sollevare, non spingere, per evitare di graffiare il pavimento e danneggiare la stabilità del letto.

## English

### IMPORTANT ! KEEP FOR FUTURE REFERENCE : READ CAREFULLY

- To be assembled by an adult. Assembly must be checked by an adult before use
- WARNING ! Keep all screws, small parts and plastic bags out of the reach of children
- Properly identify all parts before assembling
- Never use your item if any of its parts are broken or missing
- Should any problems arise, please contact our After Sales Service
- Manufacturer's instructions shall be followed at all times
- Care: Clean with a soft, dry cloth. In case of larger stains, carefully rub with a slightly damp, non-abrasive sponge
- Avoid the risk of fire by not placing furniture near sources of ignition or hot items
- Do not jump on the bed

## Deutsch

### WICHTIG ! ZUM SPÄTEREN NACHSCHLAGEN AUFBEWAHREN: SORGFÄLTIG LESEN

- Muss von einem Erwachsenen zusammengebaut werden. Der Zusammenbau muss vor dem Gebrauch von einem Erwachsenen überprüft werden
- WARNUNG! Bewahren Sie alle Schrauben, Kleinteile und Plastikbeutel außerhalb der Reichweite von Kindern auf
- Kennzeichnen Sie vor dem Zusammenbau alle Teile richtig
- Benutzen Sie Ihren Artikel niemals, wenn Teile gebrochen sind oder fehlen
- Sollten Probleme auftreten, wenden Sie sich bitte an unseren Kundendienst
- Die Anweisungen des Herstellers sind stets zu befolgen
- Pflege: Mit einem weichen, trockenen Tuch reinigen. Bei größeren Flecken vorsichtig mit einem leicht feuchten, nicht scheuernden Schwamm abreiben. nicht scheuernden Schwamm
- Vermeiden Sie die Gefahr eines Brandes, indem Sie die Möbel nicht in der Nähe von Zündquellen oder heißen Gegenständen aufstellen
- Nicht auf das Bett springen

## Français

### IMPORTANT ! CONSERVER POUR RÉFÉRENCE ULTÉRIEURE : LIRE ATTENTIVEMENT

- Le montage doit être effectué par un adulte. Le montage doit être vérifié par un adulte avant Utilisation
- ATTENTION ! Tenir les vis, les petites pièces et les sachets en plastique hors de portée des enfants
- Identifiez correctement toutes les pièces avant de les assembler
- N'utilisez jamais votre article si l'une de ses pièces est cassée ou manquante
- En cas de problème, veuillez contacter notre service après-vente
- Les instructions du fabricant doivent être respectées à tout moment
- Entretien : nettoyer avec un chiffon doux et sec. En cas de taches plus importantes, frotter soigneusement avec une éponge non abrasive légèrement humide. légèrement humide et non Abrasive
- Évitez les risques d'incendie en ne plaçant pas les meubles à proximité de sources d'inflammation ou d'objets chauds
- Ne pas sauter sur le lit

## Italiano

### IMPORTANTE! CONSERVARE PER RIFERIMENTO FUTURO: LEGGERE ATTENTAMENTE

- Deve essere assemblato da un adulto. L'assemblaggio deve essere controllato da un adulto prima dell'uso
- **ATTENZIONE!** Tenere tutte le viti, le piccole parti e i sacchetti di plastica fuori dalla portata dei bambini
- Identificare correttamente tutte le parti prima dell'assemblaggio
- Non utilizzare mai l'articolo se alcune parti sono rotte o mancanti
- In caso di problemi, si prega di contattare il nostro Servizio Post Vendita
- Le istruzioni del produttore devono essere sempre seguite
- Cura: Pulire con un panno morbido e asciutto. In caso di macchie più estese, strofinare accuratamente con una spugna leggermente umida e non abrasiva
- Evitare il rischio di incendio, non collocando i mobili vicino a fonti di accensione o a oggetti caldi
- Non saltare sul letto

## Español

### ¡ IMPORTANTE ! CONSERVELO PARA FUTURAS CONSULTAS: LEA ATENTAMENTE

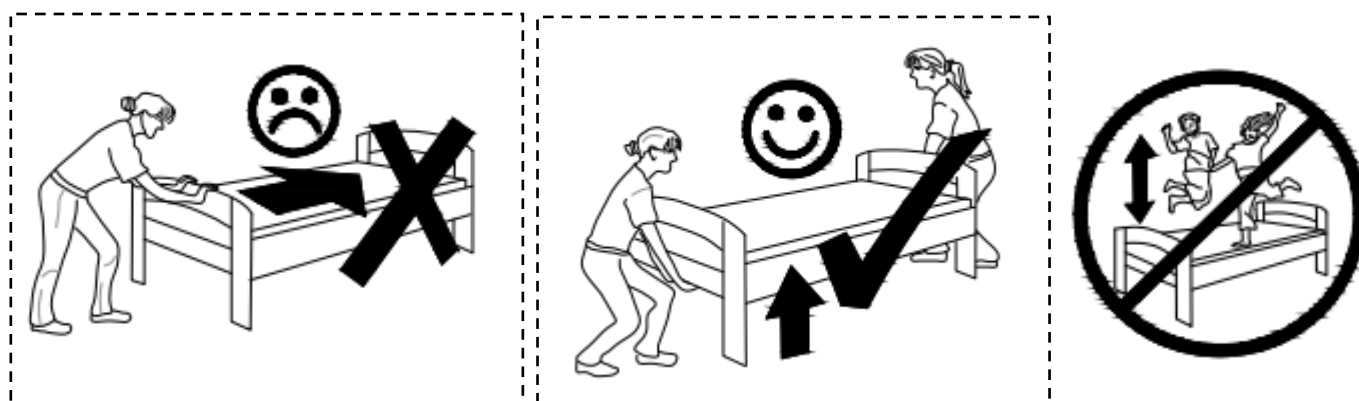

- Debe ser montado por un adulto. El montaje debe ser comprobado por un adulto antes del uso
- ADVERTENCIA Mantenga todos los tornillos, piezas pequeñas y bolsas de plástico fuera del alcance de los niños.
- Identifique correctamente todas las piezas antes de montarlas
  - Nunca utilice su artículo si alguna de sus piezas está rota o falta
  - Si surge algún problema, póngase en contacto con nuestro Servicio Postventa
  - Las instrucciones del fabricante deben seguirse en todo momento
  - Cuidado: Limpiar con un paño suave y seco. En caso de manchas más grandes, frote cuidadosamente con una esponja no abrasiva ligeramente humedecida.
  - Evite el riesgo de incendio no colocando los muebles cerca de fuentes de ignición u objetos calientes.
  - No saltar sobre la cama.

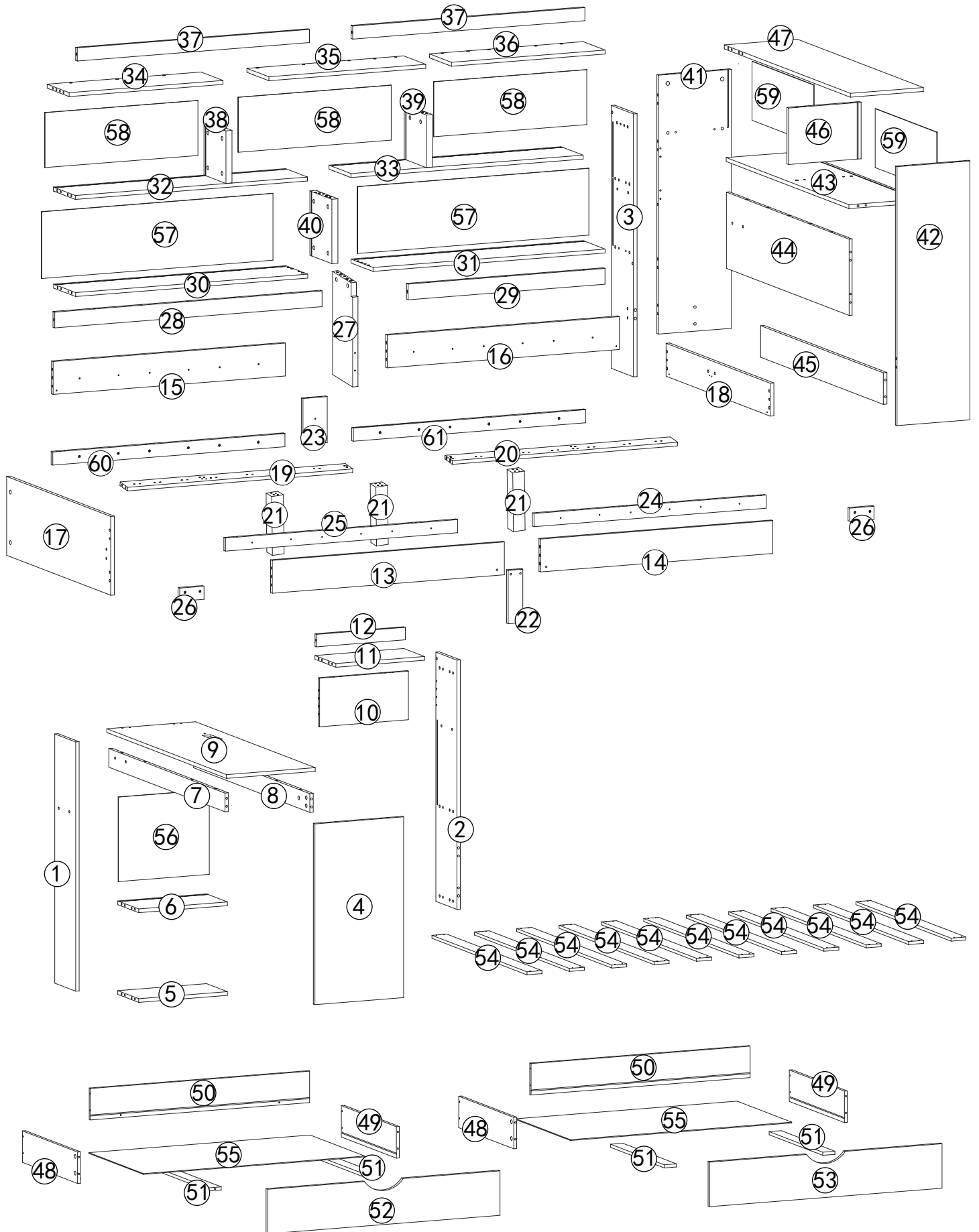

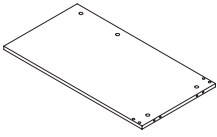
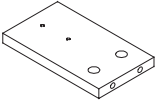

**BOX-1/4**

(N601P343828)

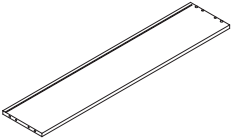
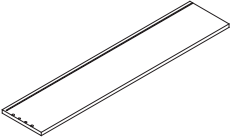
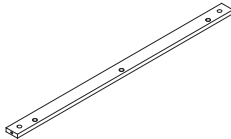
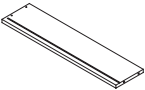
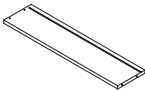
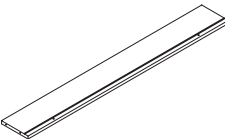
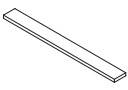
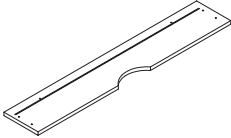
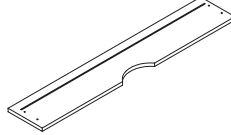
NO.	PARTS	QTY
4		1
23		1
27		1
30		1
31		1
37		2
48		2
49		2
50		2
51		4
52		1
53		1

**BOX-1/4**

(N601P343828)

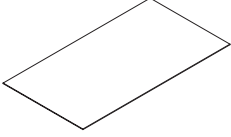
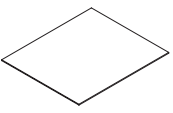
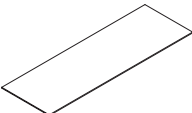
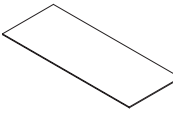
NO.	PARTS	QTY
55		2
56		1
58		3
59		2

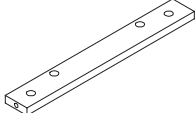
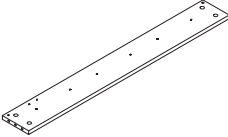
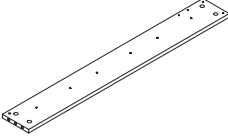
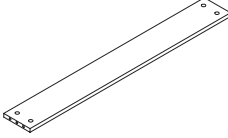
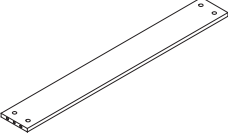
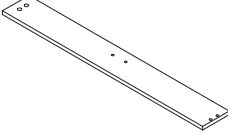

**BOX-2/4**

(N601P343829)

NO.	PARTS	QTY
12		1
13		1
14		1
15		1
16		1
18		1

**BOX-2/4**

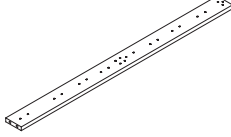
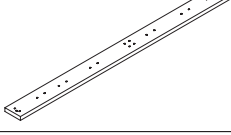
(N601P343829)

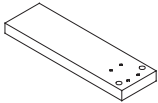
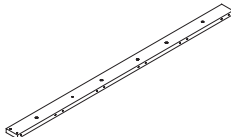
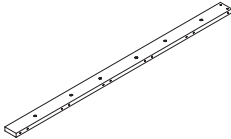
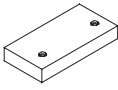
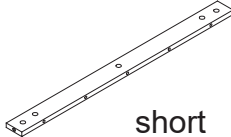
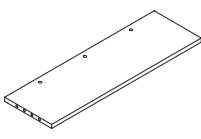
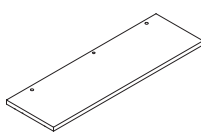
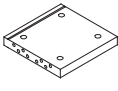
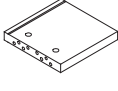
NO.	PARTS	QTY
19		1
20		1
21		3
22		1
24		1
25		1
26		2
29	 short	1
34		1
36		1
38		1
39		1

**BOX-2/4**

(N601P343829)

NO.	PARTS	QTY
40		1
41		1
42		1
60		1
61		1

**BOX-3/4**

(N601P343830)

NO.	PARTS	QTY
17		1
32		1
33		1
35		1
43		1
46		1
57		2
	 Hardware kit	1

**BOX-4/4**

(N601P343831)

NO.	PARTS	QTY
7		1
8		1
9		1
10		1
28	 long	1
44		1
45		1
47		1
54		11











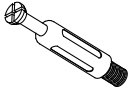



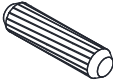
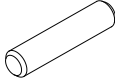

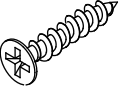
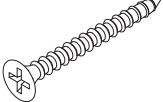
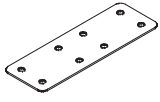

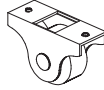
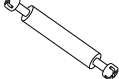
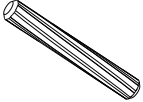
**BOX-3/4**

(N601P343830)

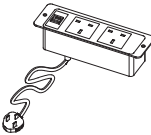
1		1
2		1
3		1
5		1
6		1
11		1

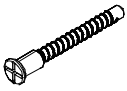
# Hardware N601P343834

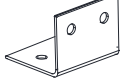
PARTS

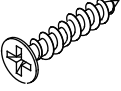
<p><b>A</b> x95 6x40mm</p> 	<p><b>B</b> x111 15x12mm</p> 	<p><b>C</b> x55 6x28mm</p> 	<p><b>D</b> x55 15x10mm</p> 	<p><b>E</b> x64 8x40mm</p> 	<p><b>F</b> x38 6x30mm</p> 	<p><b>G</b> x102 3.5x14mm</p> 
<p><b>H</b> x28 3.5x25mm</p> 	<p><b>J</b> x10 3.5x35mm</p> 	<p><b>K</b> x1</p> 	<p><b>L</b> x6</p> 	<p><b>M</b> x36</p> 	<p><b>N</b> x8</p> 	<p><b>O</b> x8 6x64mm</p> 
<p><b>P</b> x2 8x60mm</p> 	<p><b>Q</b> x6</p> 	<p><b>R</b> x8 6x15mm</p> 	<p><b>S</b> x8 6x20mm</p> 	<p><b>T</b> x1</p> 	<p><b>U</b> x200</p> 	<p><b>V</b> x16 5x40mm</p> 
<p><b>W</b> x12 6x10mm</p> 	<p><b>X</b> x3</p> 	<p><b>Y</b> x2</p> 	<p><b>Z</b> x66 3.5x20mm</p> 			

EN: If you find that the white glue particles on the board are missing, please press part Y into the board.

DE: Sollten Sie feststellen, dass die weißen Gumpipartikel auf der Platine fehlen, drücken Sie bitte Teil Y in die Platine.

FR: Si vous constatez qu'il manque des particules de caoutchouc blanc sur le tableau, veuillez enfoncer la partie Y dans le tableau.

IT: Se trovi che mancano le particelle di gomma bianca sulla tavola, premi la parte Y sulla tavola.

ES: Si descubre que faltan las partículas de goma blancas en el tablero, presione la parte Y en el tablero.

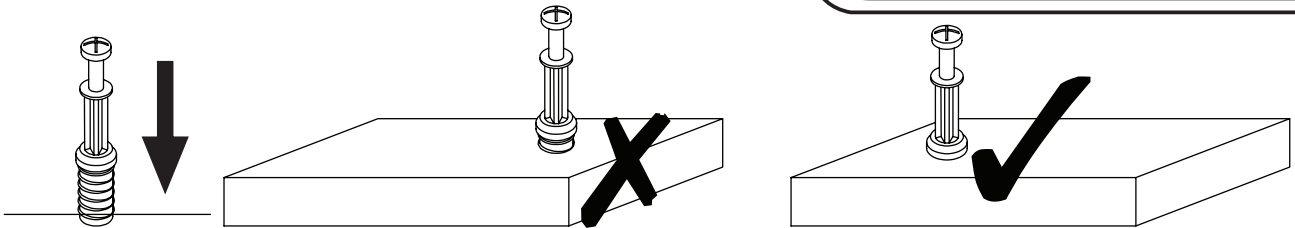

**EN\_QUICKFIT:** Tighten quickfit until shoulder is flush with panel. Do not overtighten or undertighten.

**FR\_RACCORD RAPIDE:** Faites serrer le raccord rapide jusqu'à ce que l'épaulement soit parfaitement encastré dans le panneau. Il ne faut ni trop serrer ni insuffisamment serrer.

**ES\_QUICKFIT:** Apriete quickfit hasta que el hombro se descargue con el panel. NO lo sobreapriete ni lo apriete poco.

**DE\_QUICKFIT:** Ziehen Sie den Quickfit fest, bis die Schulter mit der Platte bündig ist. Bitte nicht zu fest oder zu schwach anziehen.

**IT\_MONTAGGIO RAPIDO:** Stringere il montaggio rapido fino a quando la spalla è a filo con il pannello, non stringere troppo o troppo poco.

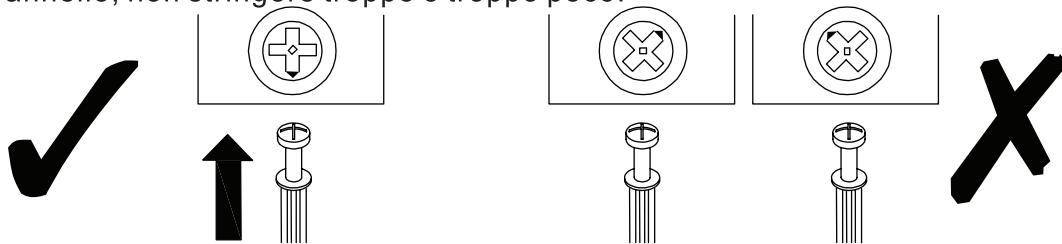

**EN\_CAM LOCK:** When fitting cam lock, ensure starting position is correct before you insert connecting quickfit.

**FR\_SERRURE BATTEUSE:** Avant d'insérer la serrure batteuse, veillez à la bonne orientation avant d'insérer le raccord rapide.

**ES\_CIERRE DE LA CÁMARA:** Cuando instale el cierre de la cámara, asegúrese de que la posición de inicio es correcta antes de que inserte el quickfit conector.

**DE\_CAM-LOCK:** Achten Sie bei der Montage des Cam-Locks auf die richtige Ausgangsposition, bevor Sie den Quickfit einsetzen.

**IT\_BLOCCAGGIO A CAMMA:** Quando si monta il bloccaggio a camma, assicurarsi che la posizione iniziale sia corretta prima di inserire il montaggio rapido di collegamento.

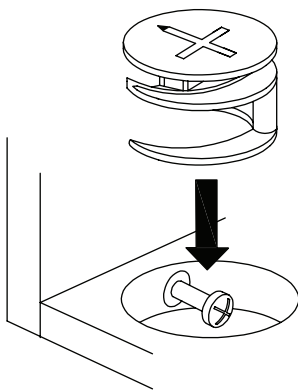

**EN\_Quickfit head** should be in the centre of the cam lock when the two panels are joined.

Cam lock should be inserted before quickfit.

**FR\_Lorsque** les deux panneaux sont assemblés, la tête du raccord rapide doit reposer au centre de la serrure batteuse. Il faut insérer la serrure batteuse avant le raccord rapide.

**ES\_El** cabezal del quickfit debe estar en el centro del cierre de la cámara cuando se unan los dos paneles.

Se debe insertar el cierre de la cámara antes que el quickfit.

**DE\_Der** Quickfit-Kopf sollte sich in der Mitte des Cam-Locks befinden, wenn die beiden Platten zusammengefügt sind. Der Cam-Lock sollte vor dem Quickfit eingesetzt werden.

**IT\_La** testa del montaggio rapido deve trovarsi al centro del bloccaggio a camma quando i due pannelli sono uniti.

Il Bloccaggio a Camma deve essere inserito prima del montaggio rapido.

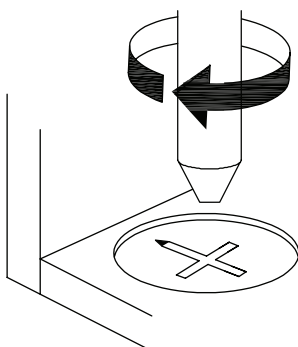

**EN\_Turn** cam lock clockwise to tighten.

**FR\_Faites** tourner la serrure batteuse dans le sens des aiguilles d'une montre pour la resserrer.

**ES\_Gire** el cierre de la cámara en sentido horario para apretarlo.

**DE\_Drehen** Sie den Cam-Lock im Uhrzeigersinn, um ihn festzuziehen.

**IT\_Ruotare** il bloccaggio a camma in senso orario per stringere.

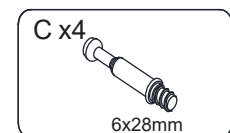
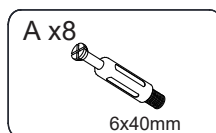
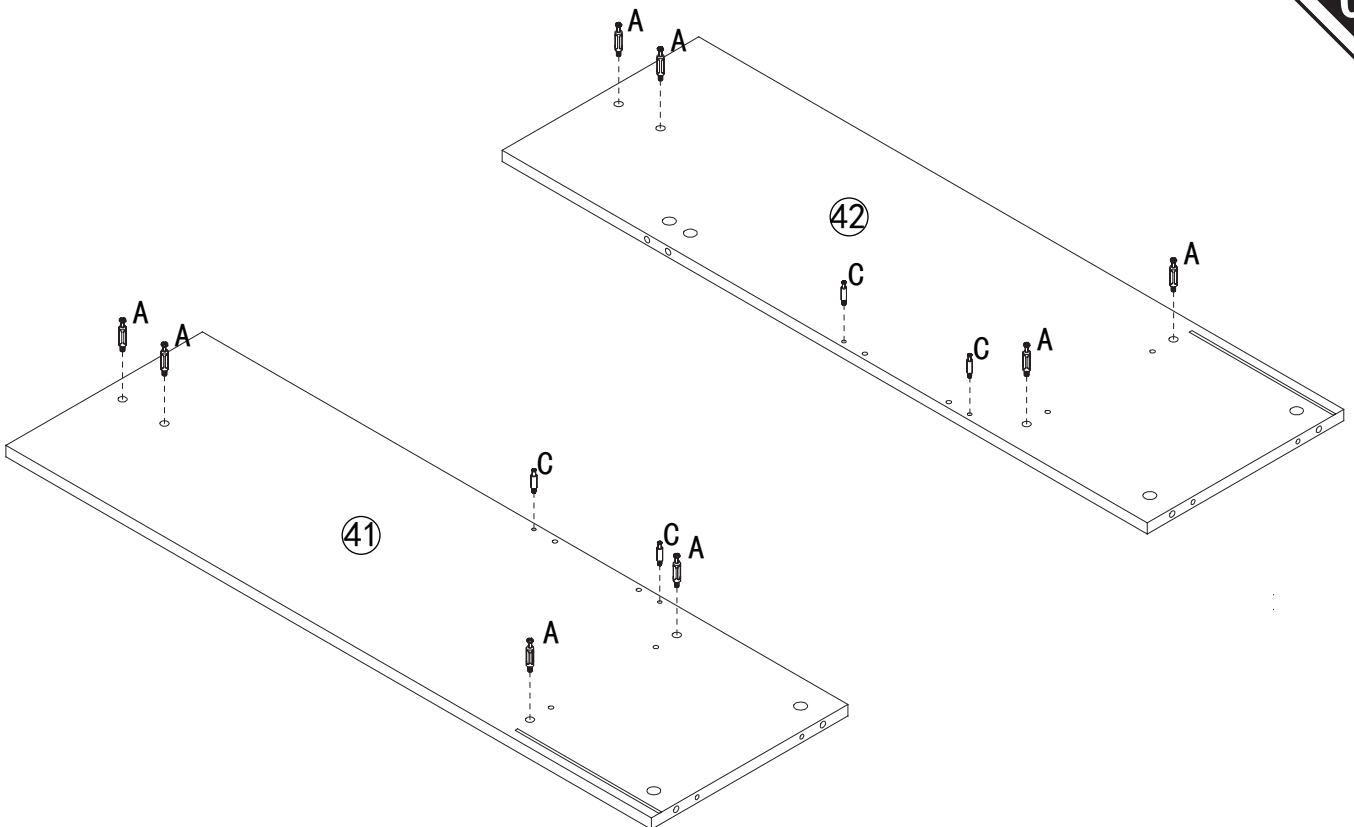
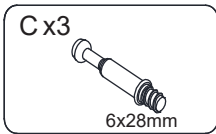
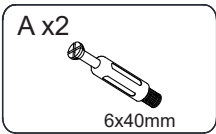
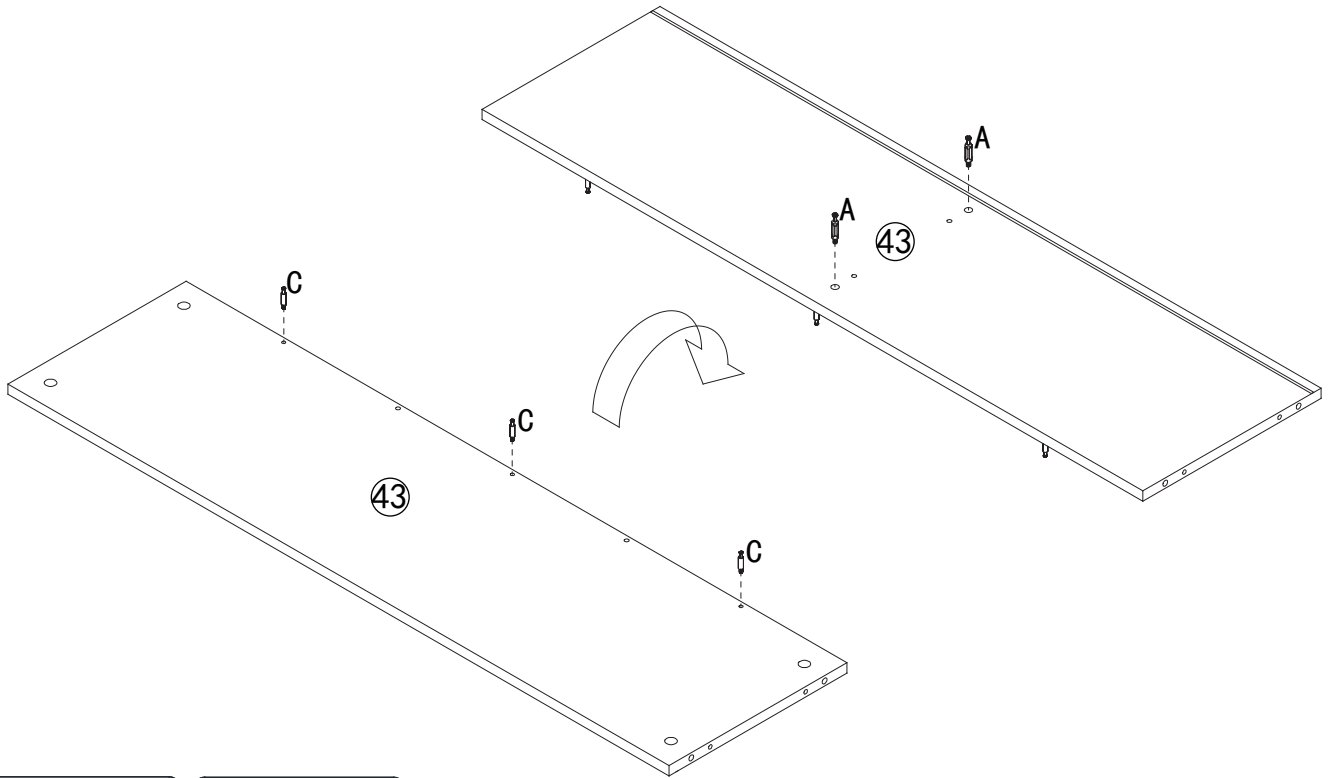

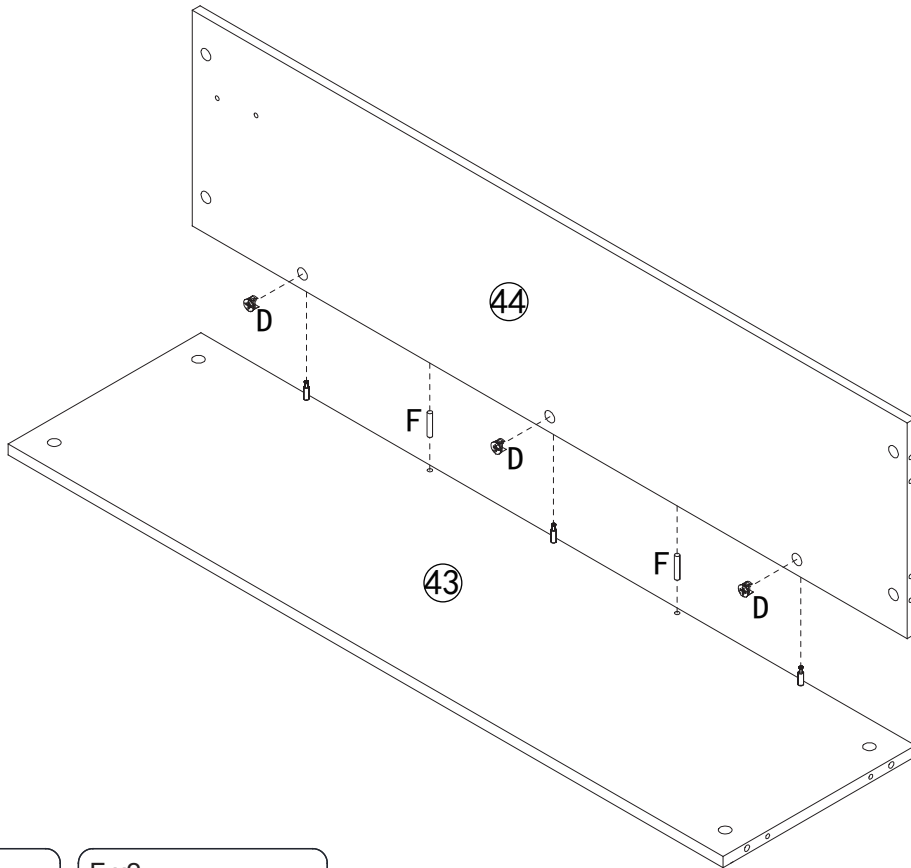

D x3



15x10mm

F x2

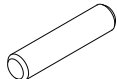

6x30mm

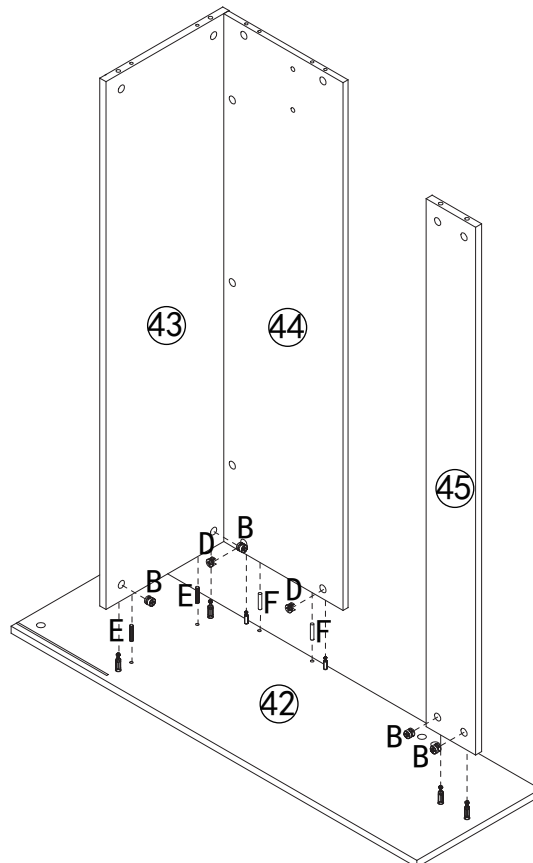

B x4



15x12mm

D x2



15x10mm

E x2

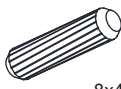

8x40mm

F x2

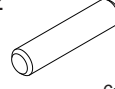

6x30mm

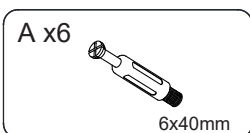
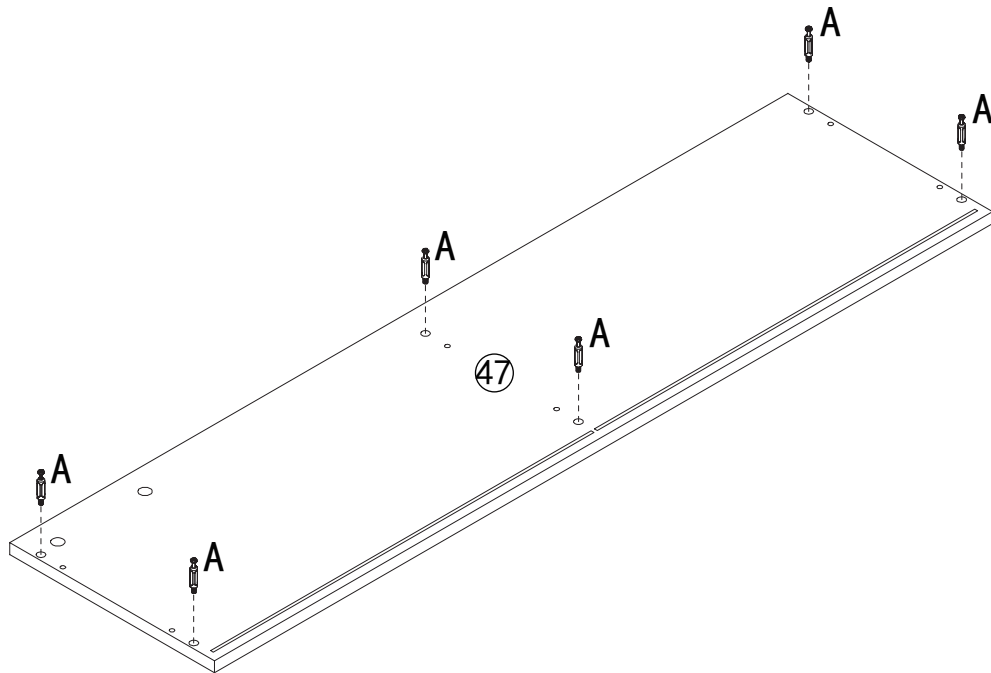
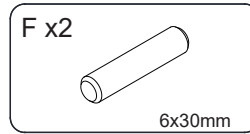
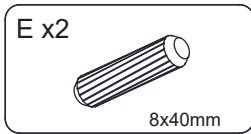
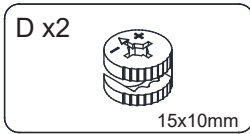
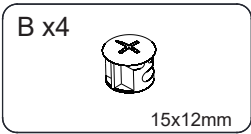
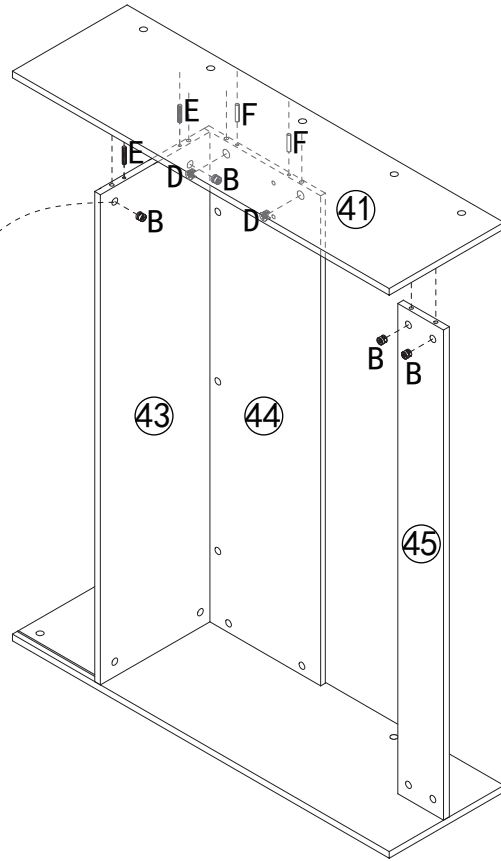
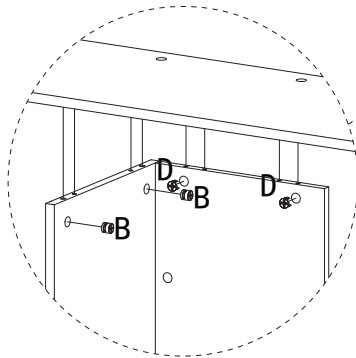
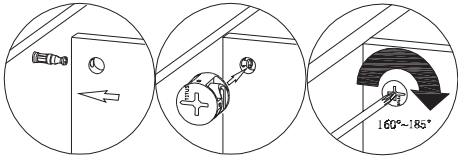

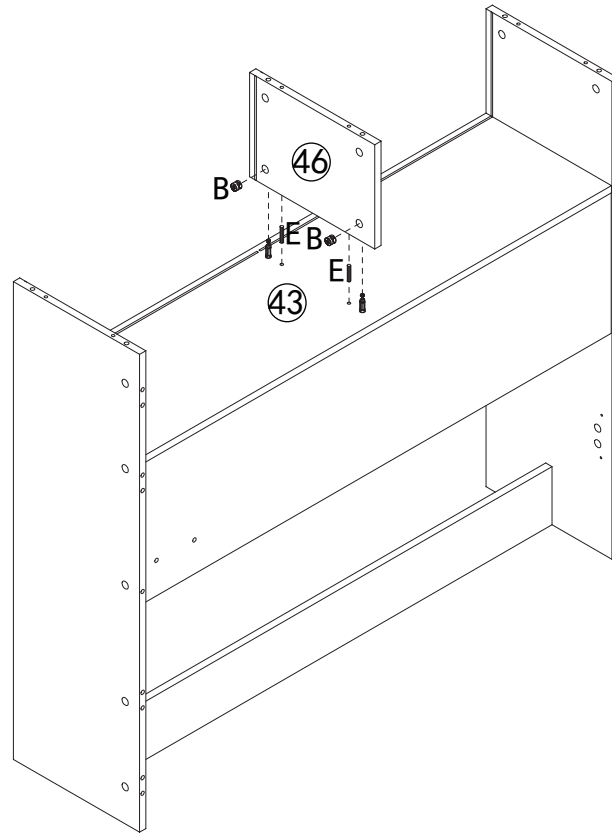

B x2



15x12mm

E x2



8x40mm

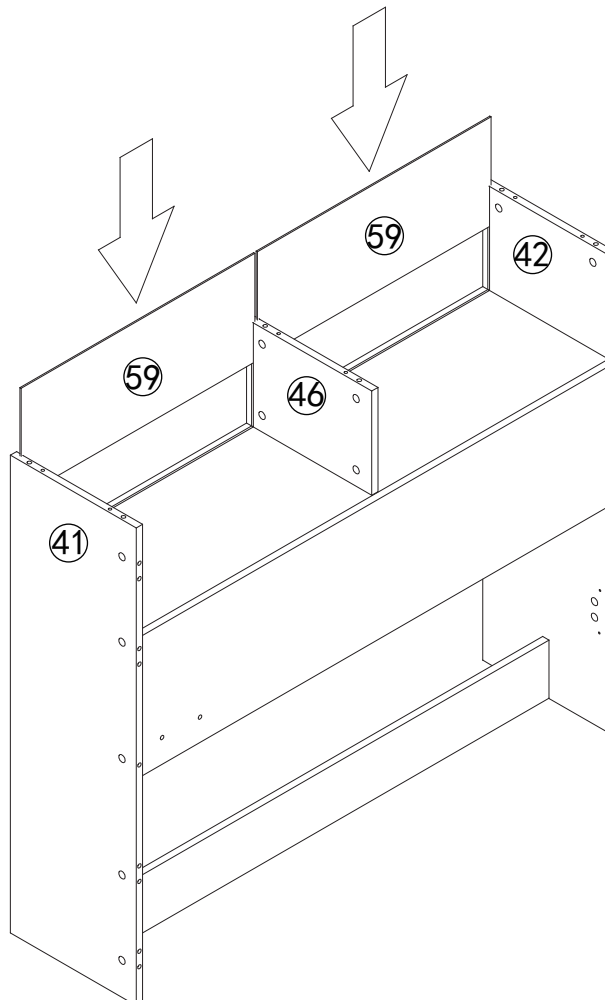

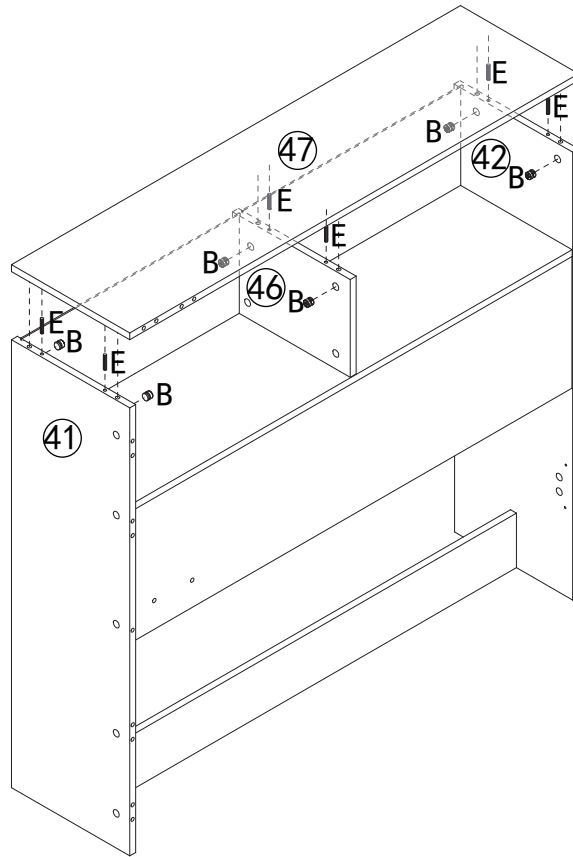

B x6



15x12mm

E x6

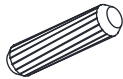

8x40mm

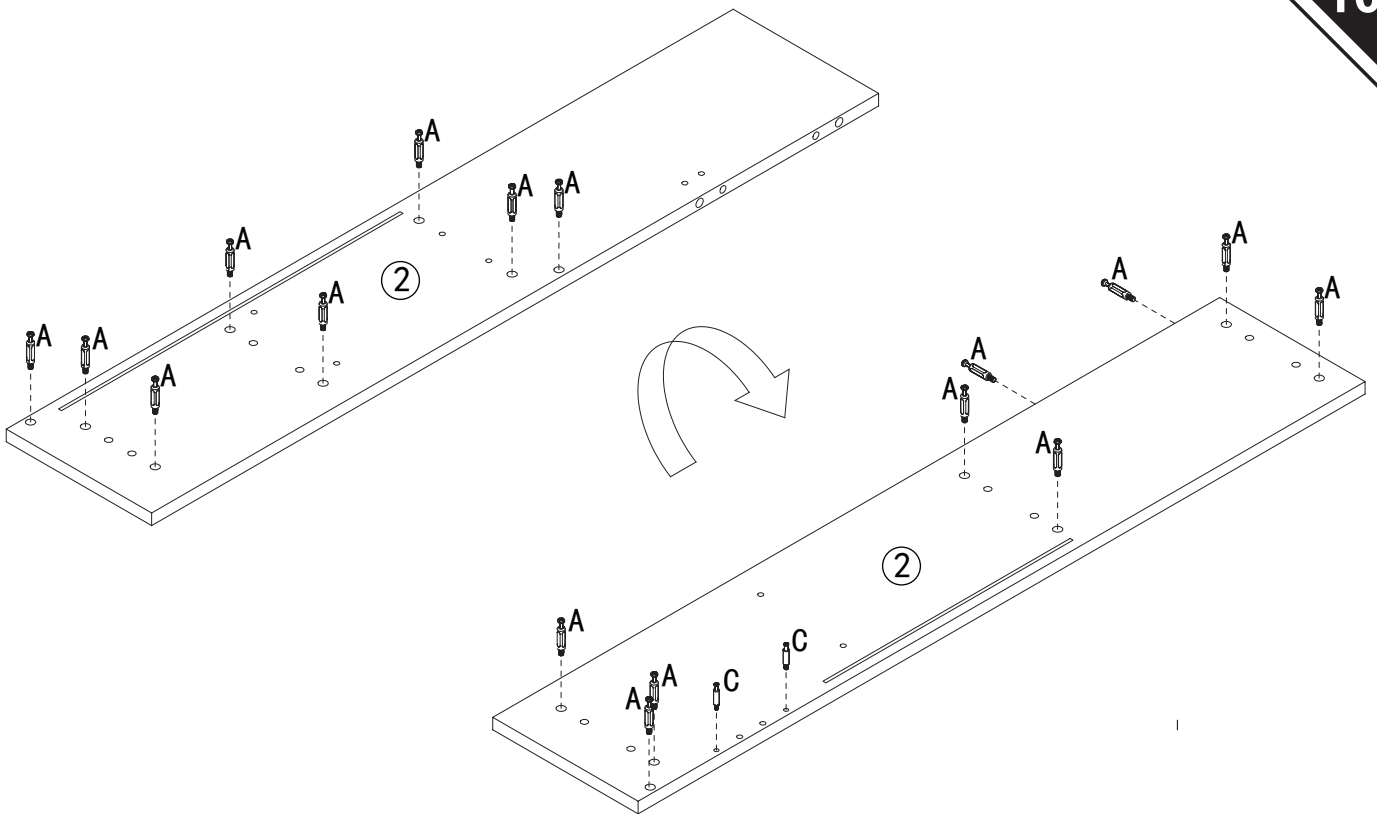

A x17

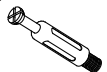

6x40mm

C x2



6x28mm

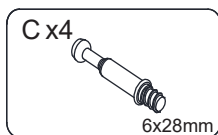
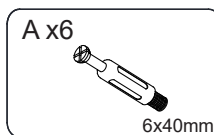
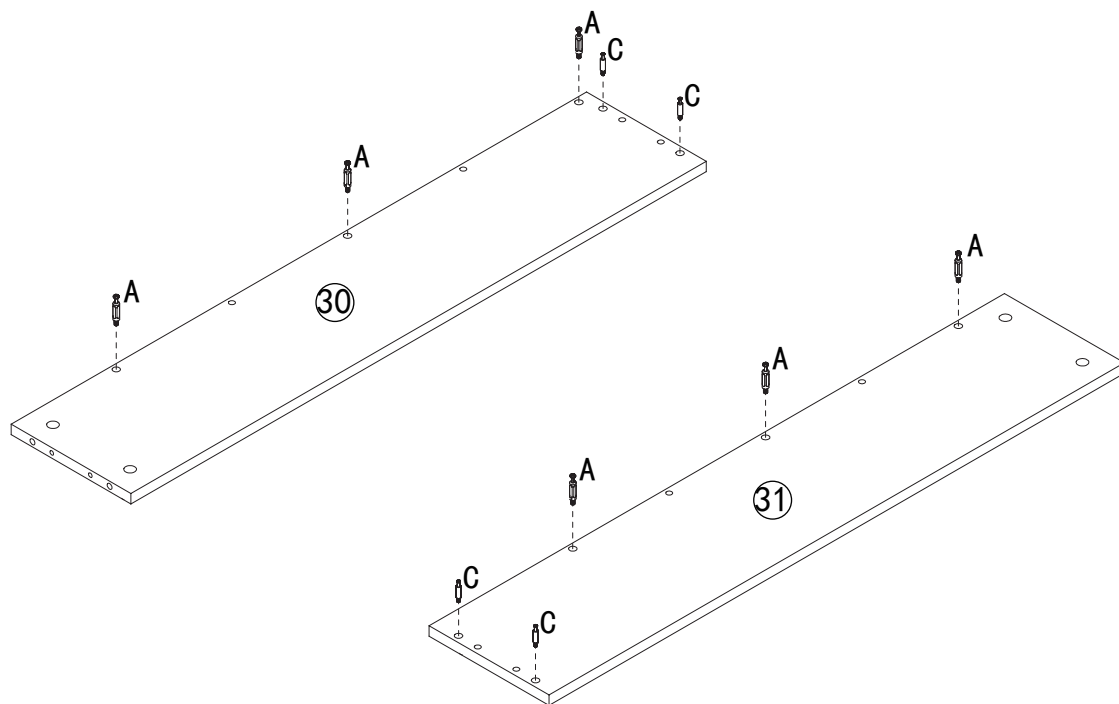
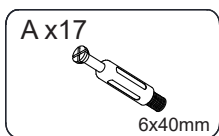
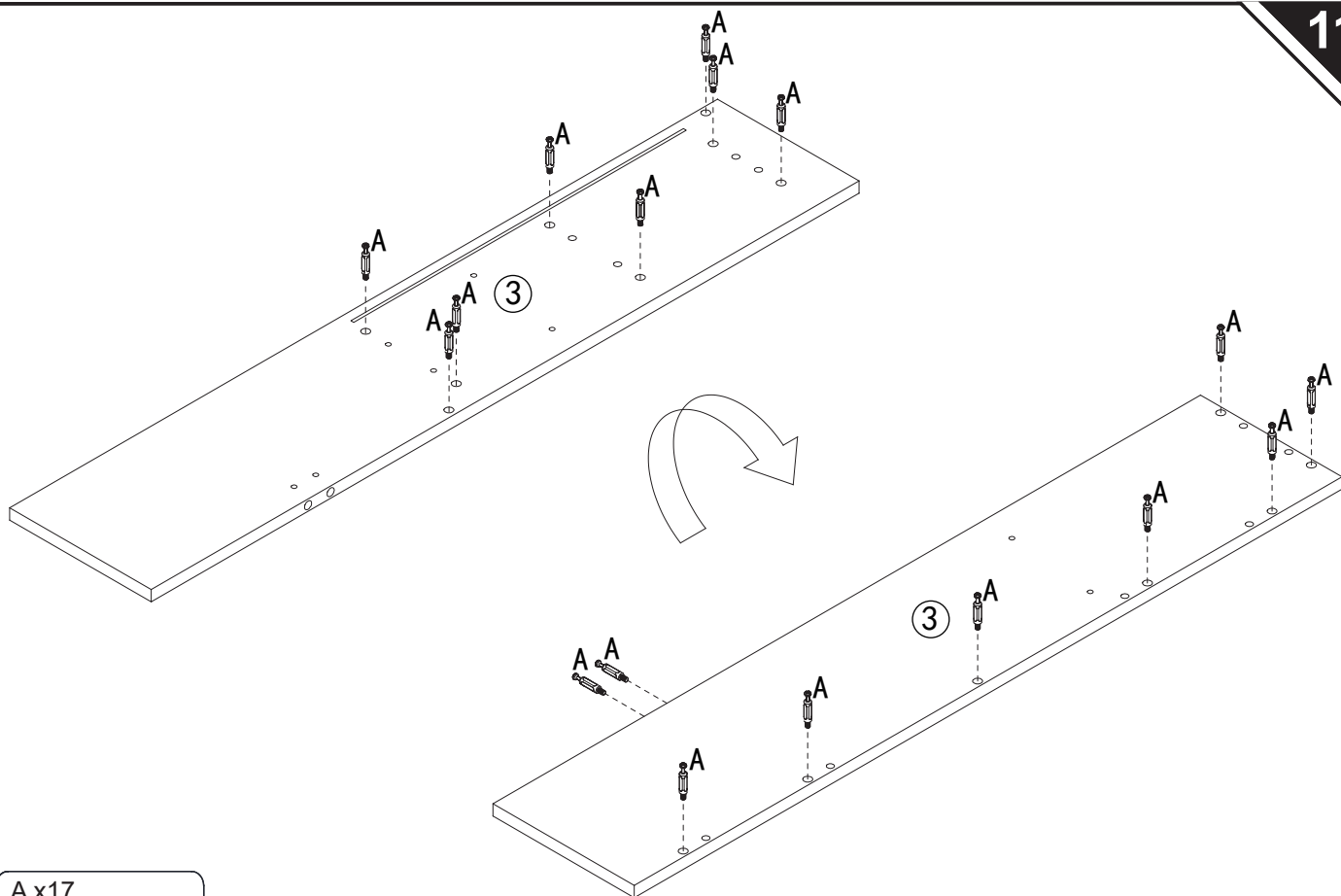

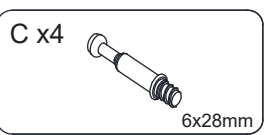
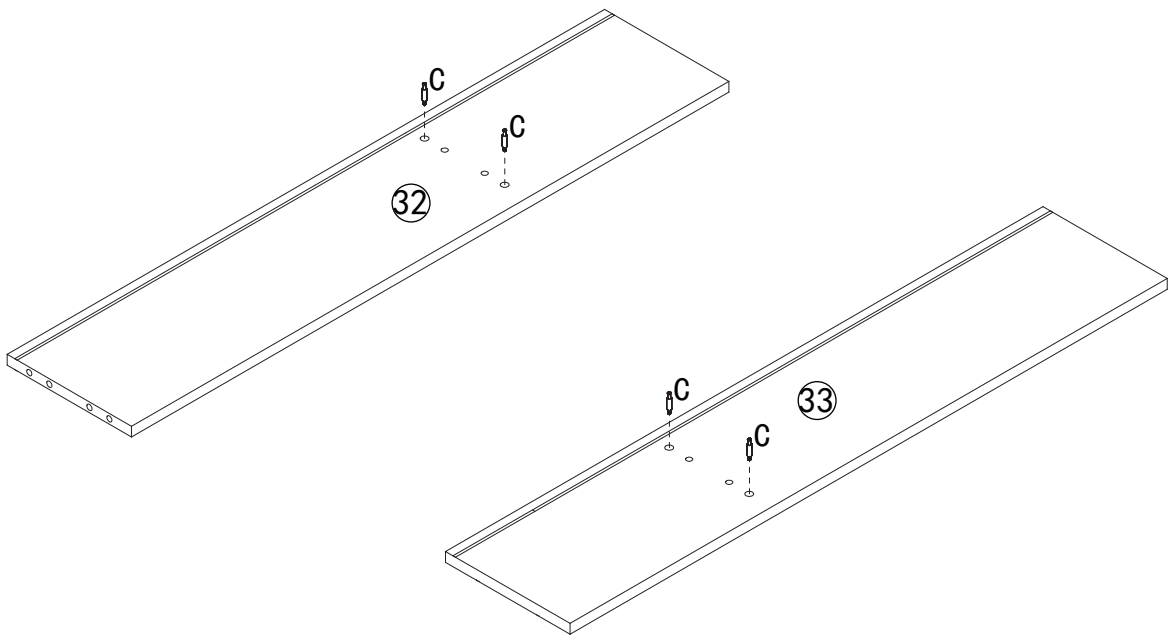
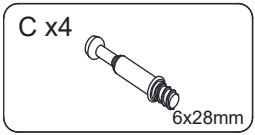
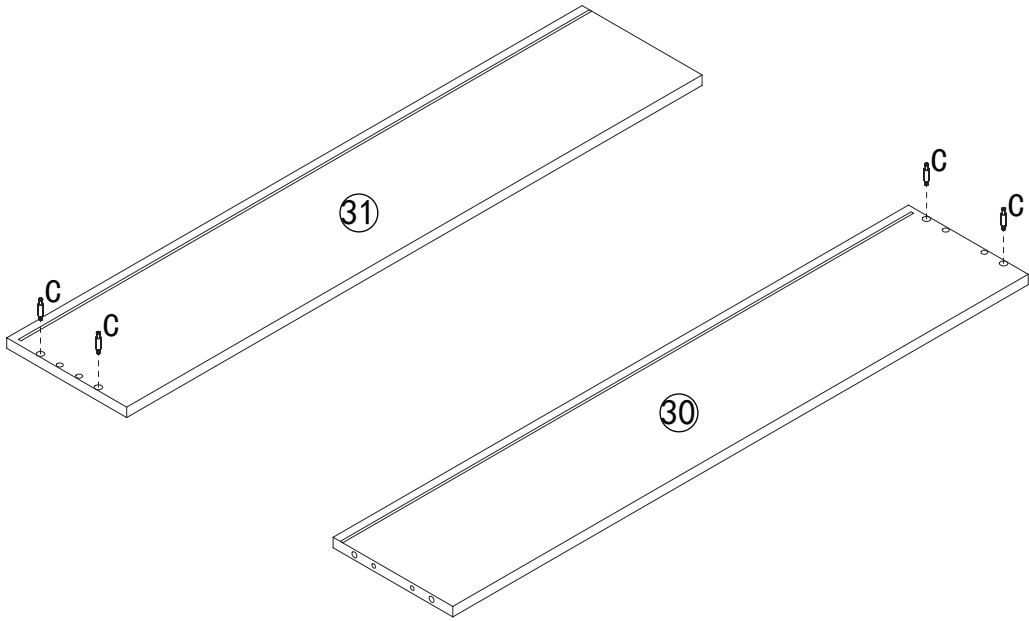

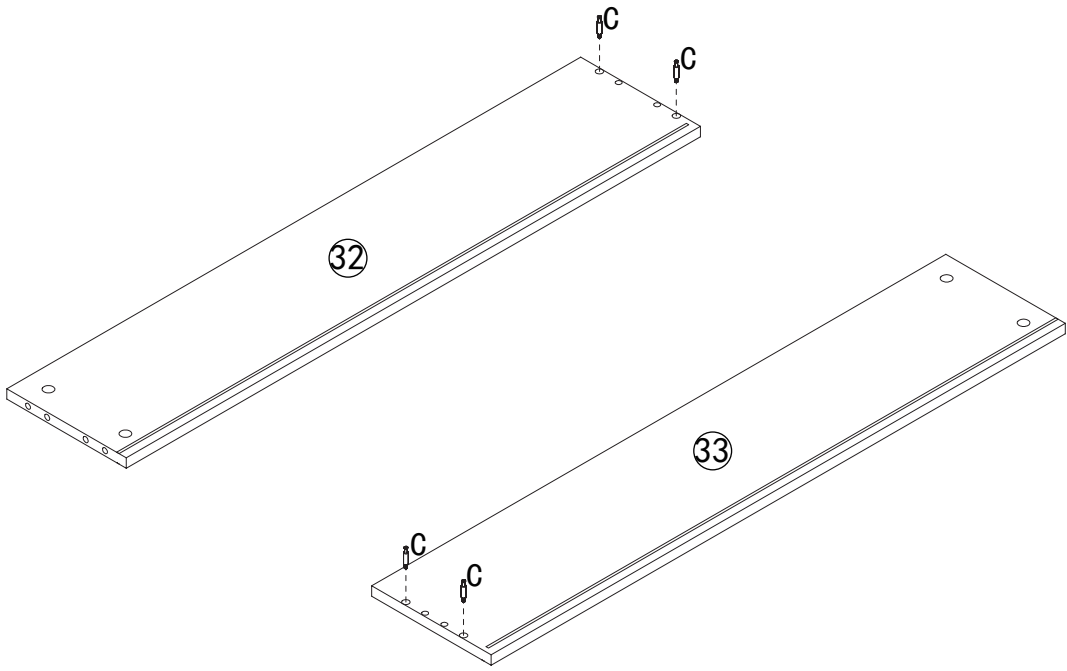

C x4

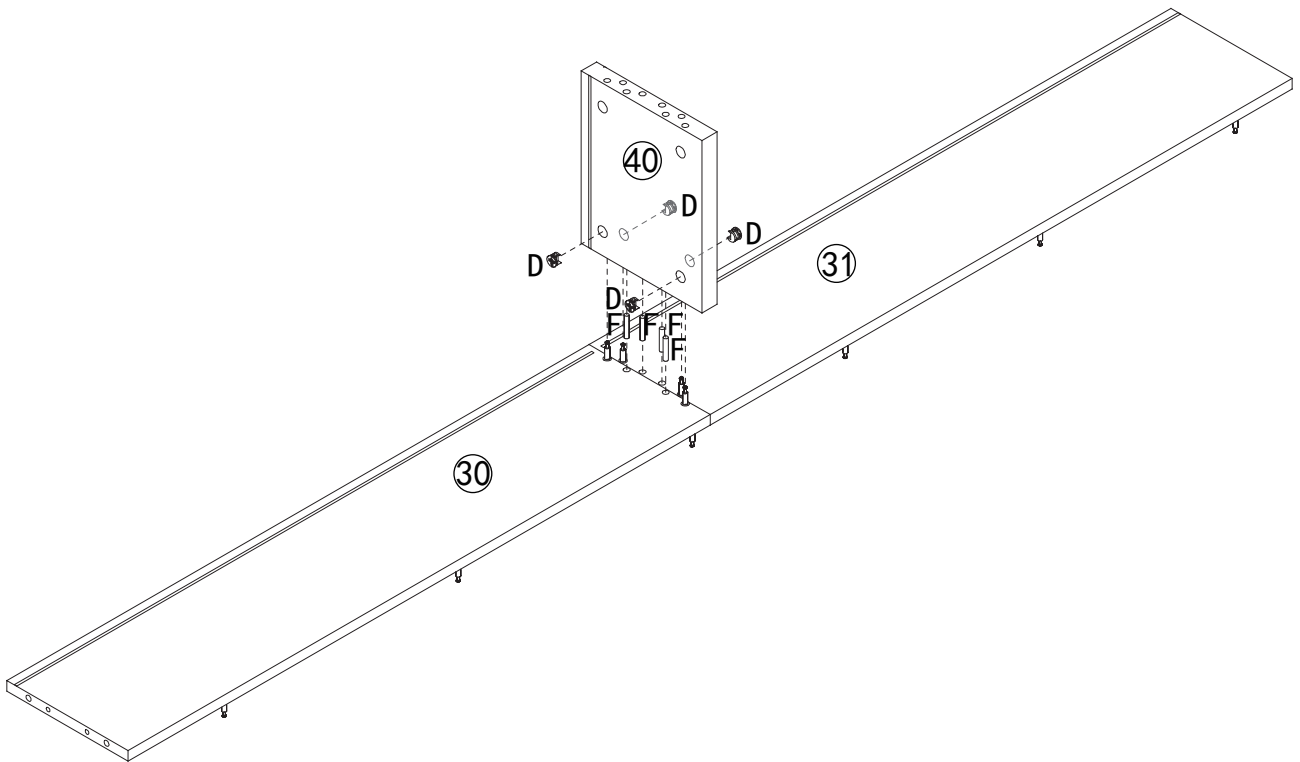

D x4

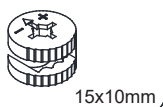

F x4

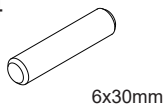

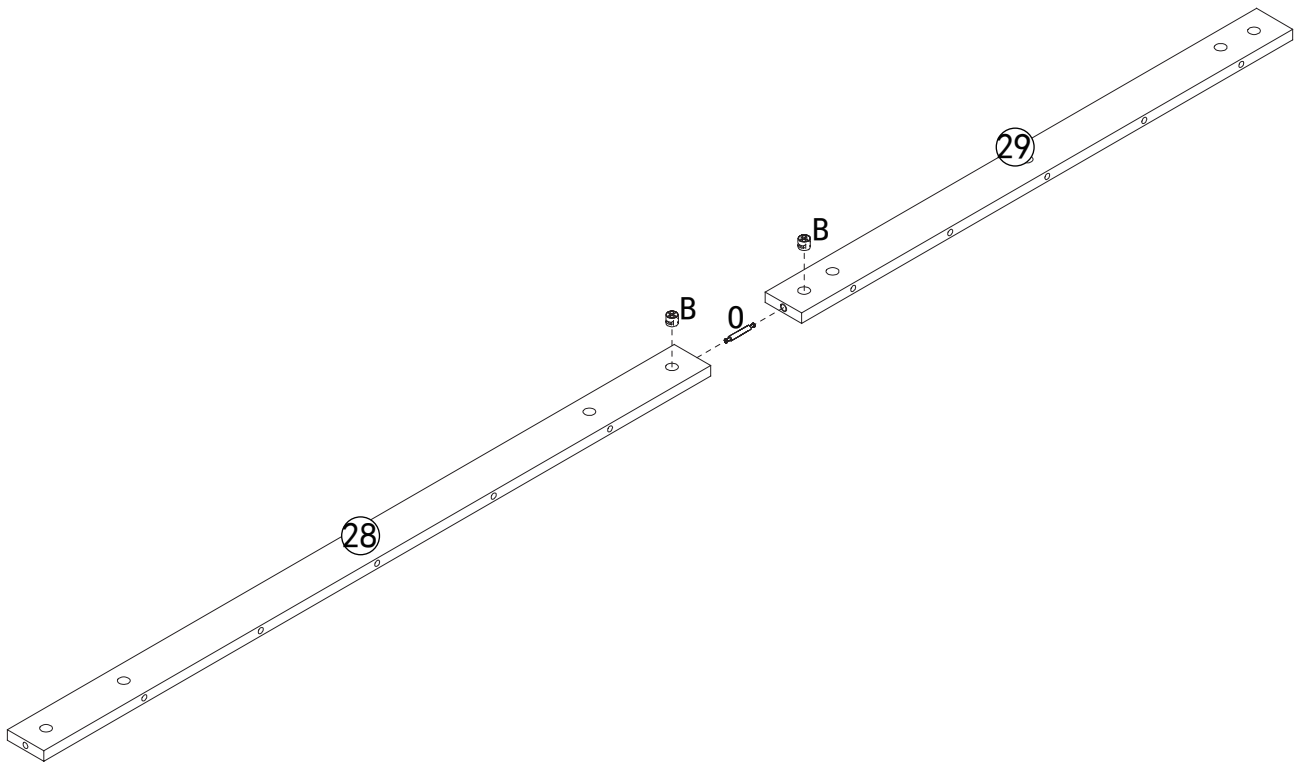

B x2  
  
 15x12mm

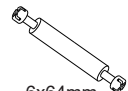
O x1  
  
 6x64mm

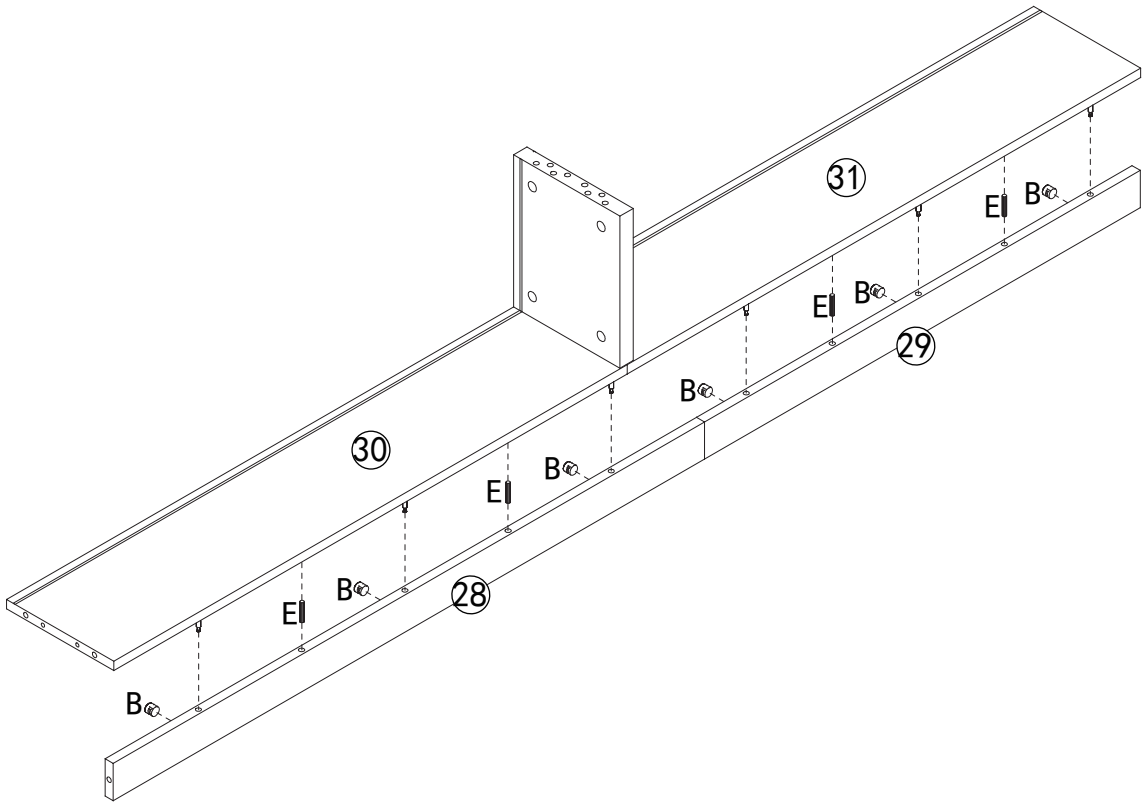

B x6  
  
 15x12mm

E x4  
  
 8x40mm

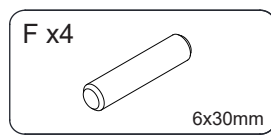
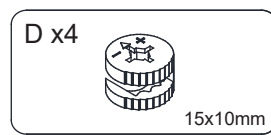
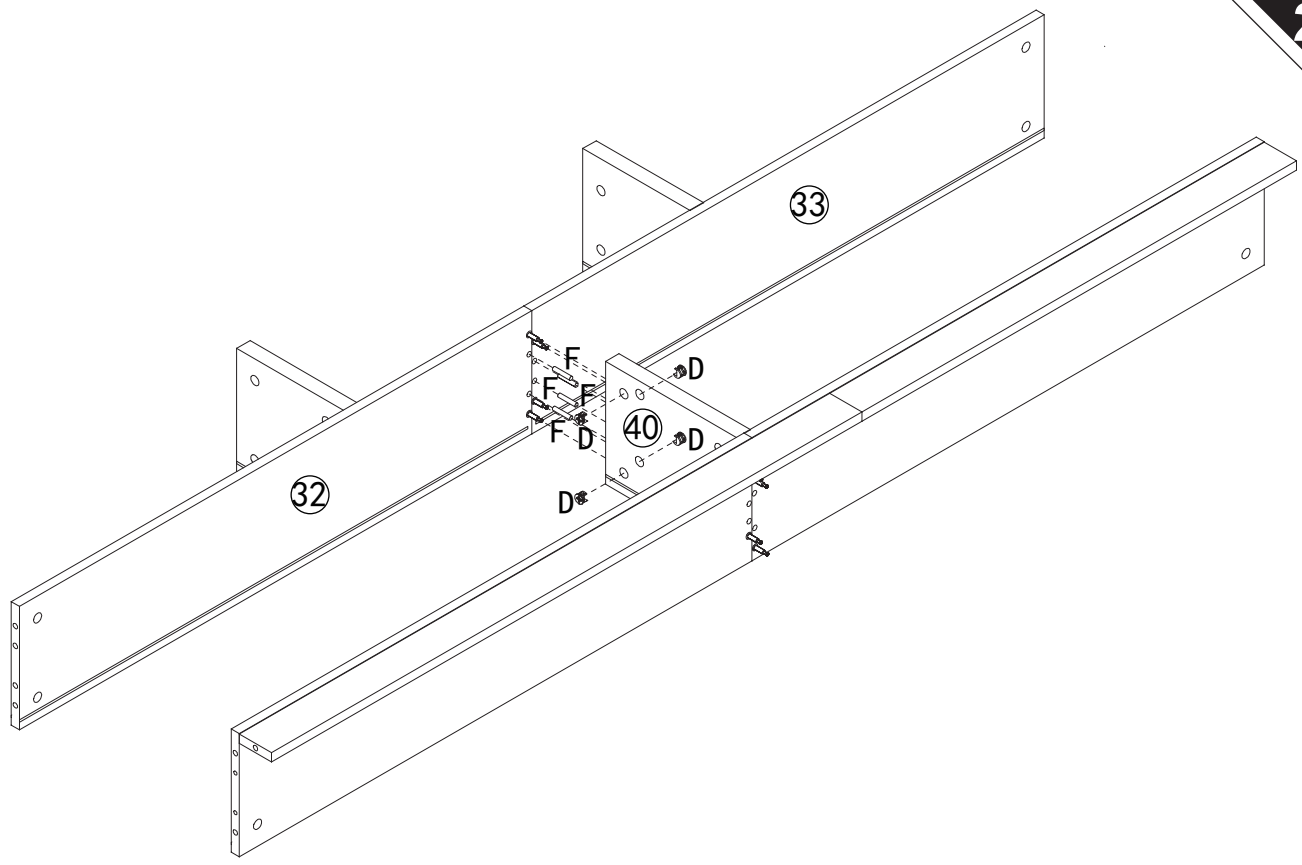
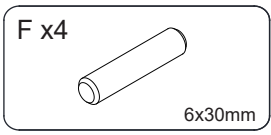
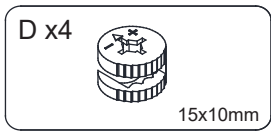
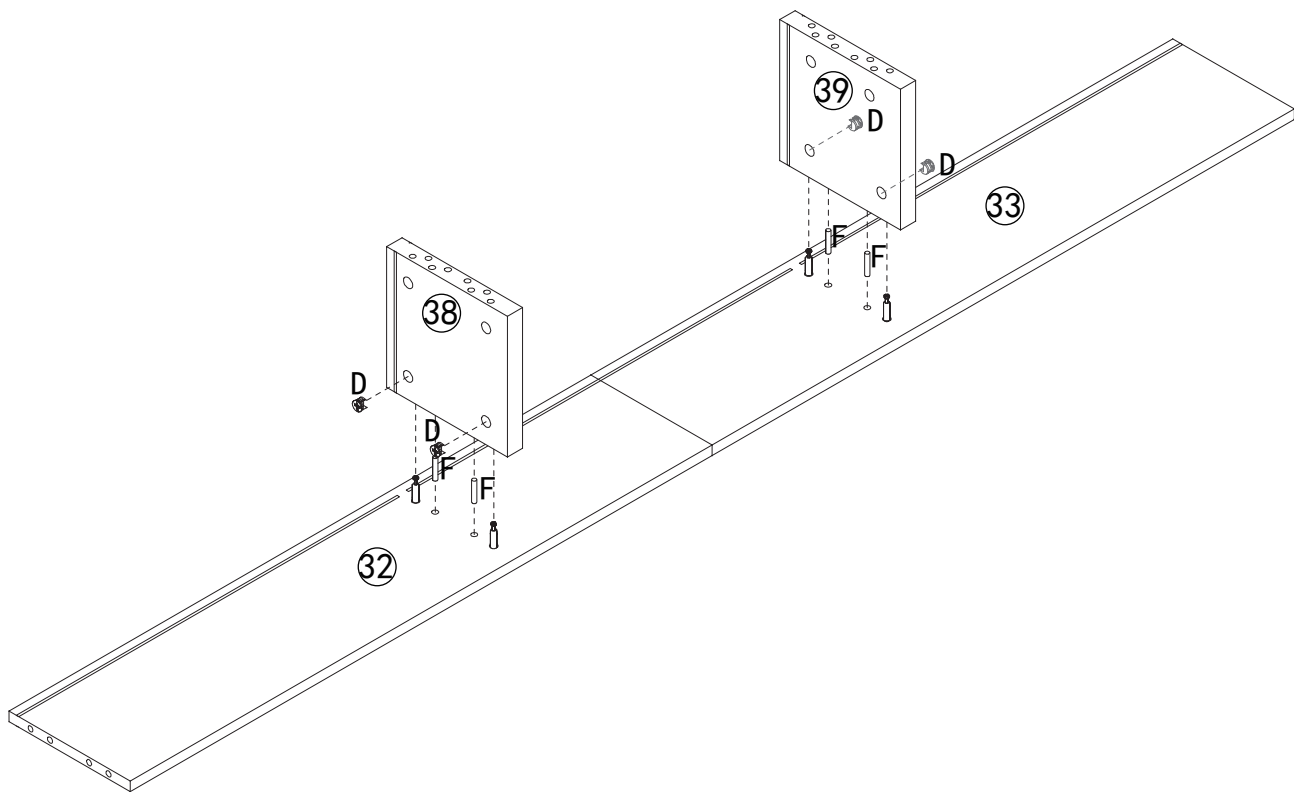

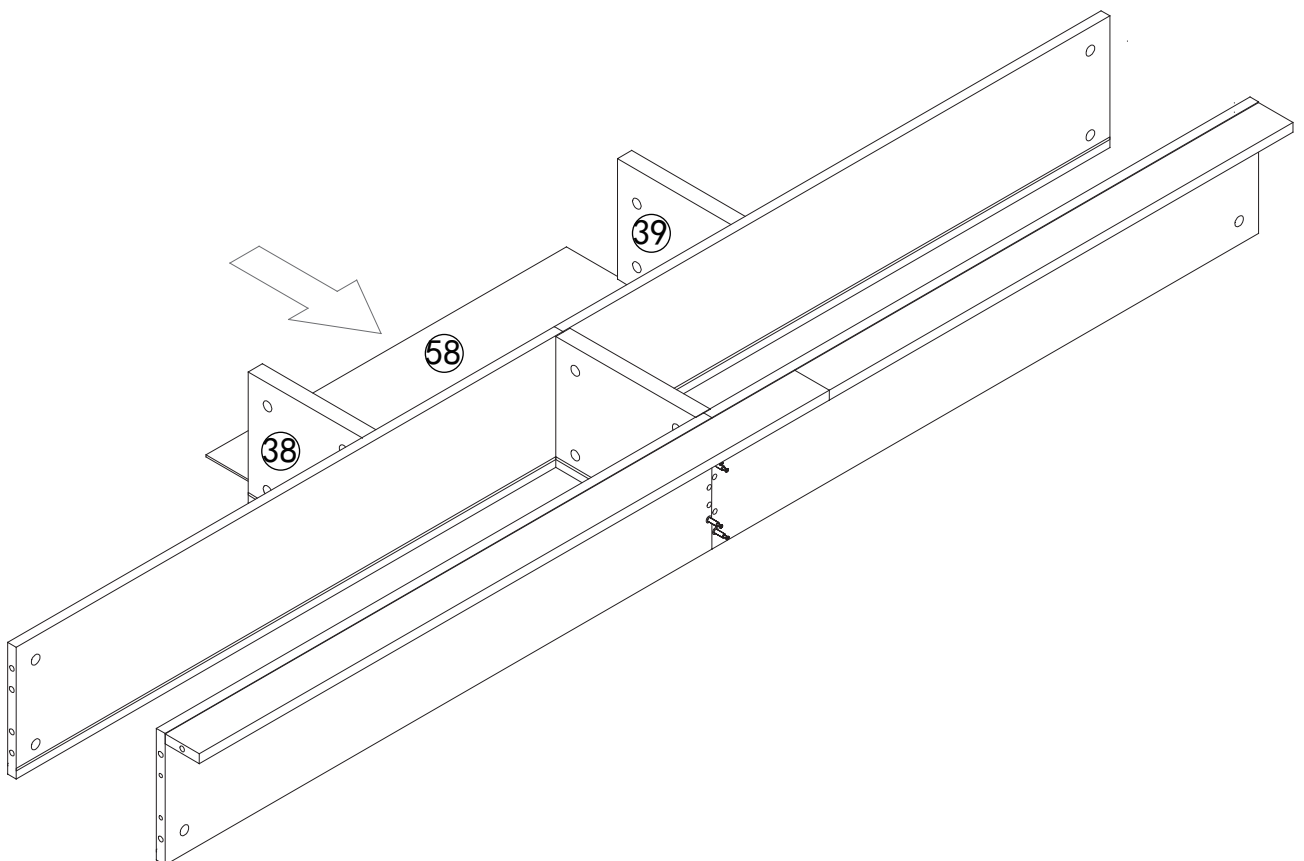
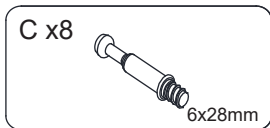
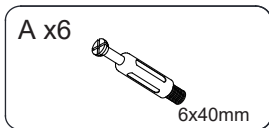
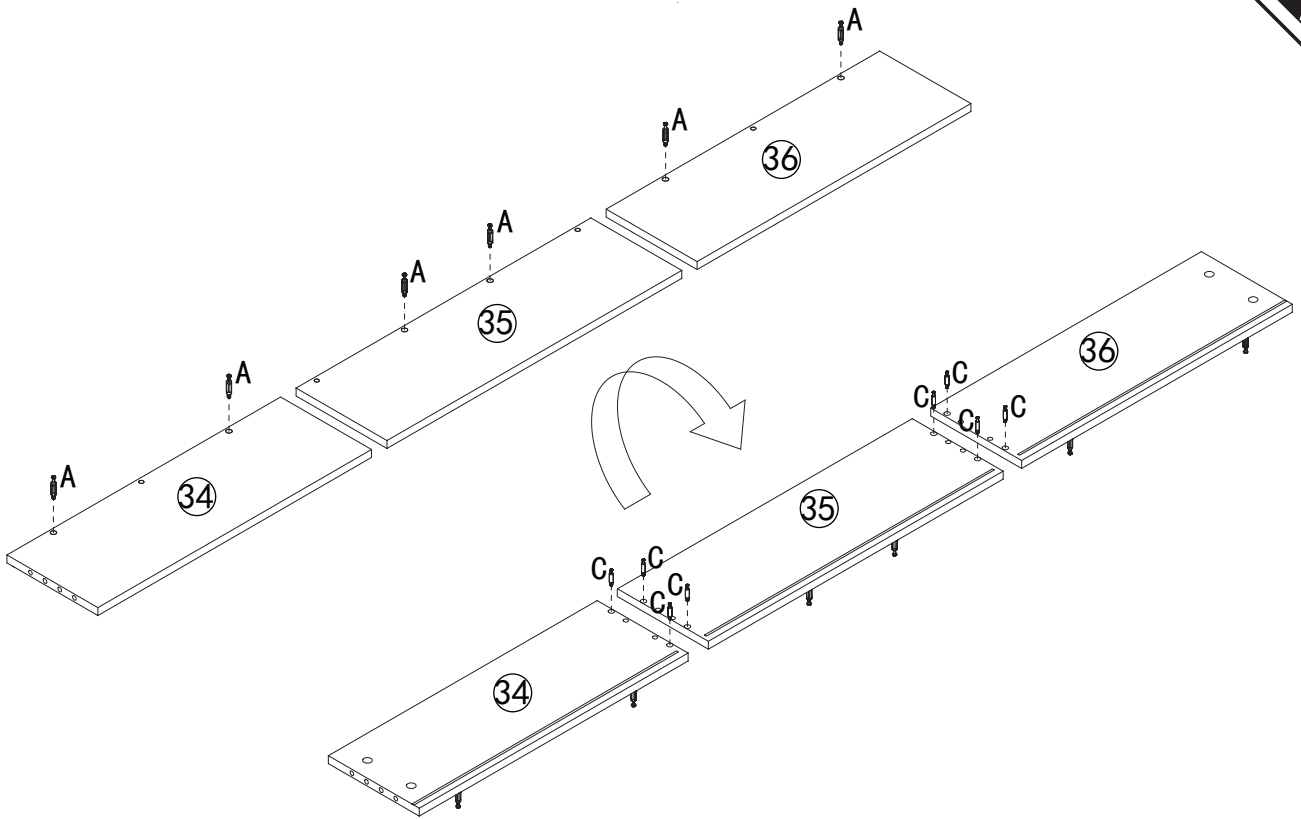

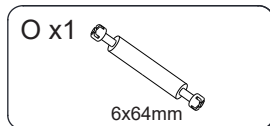
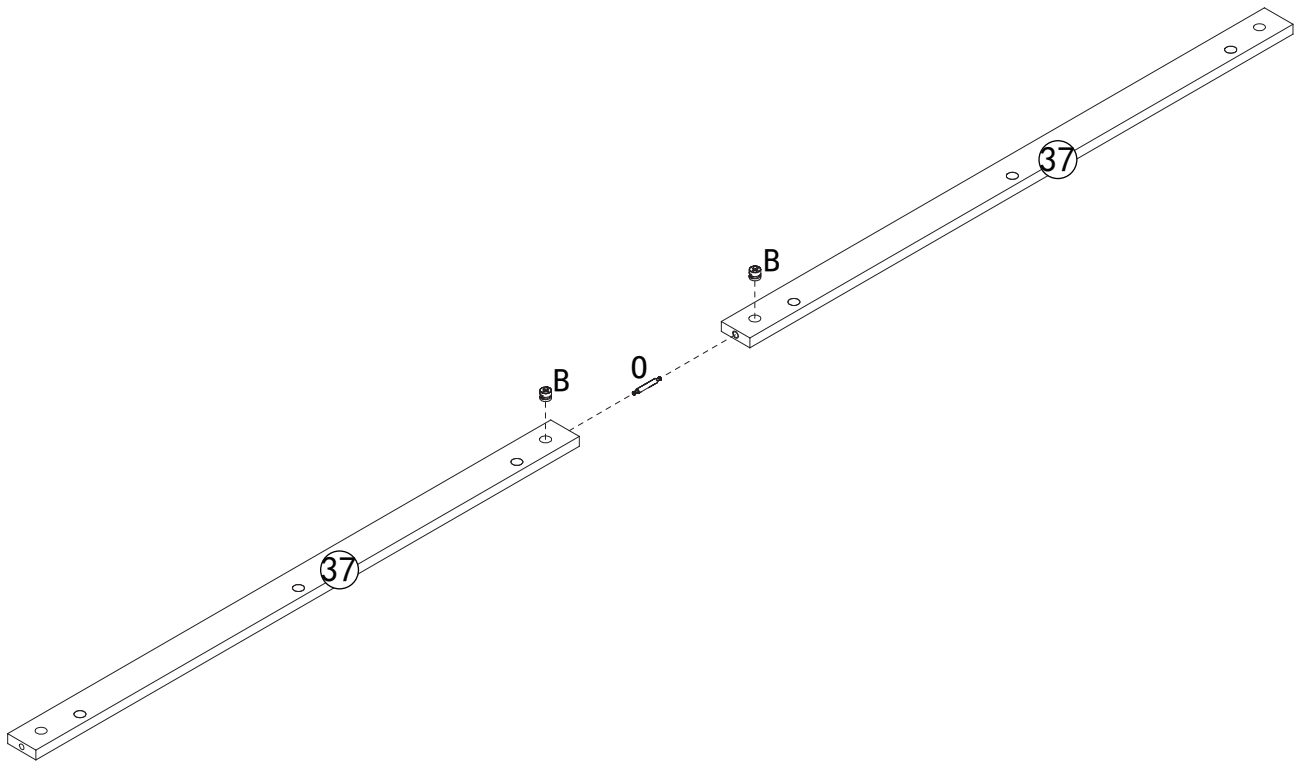
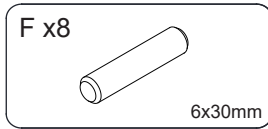
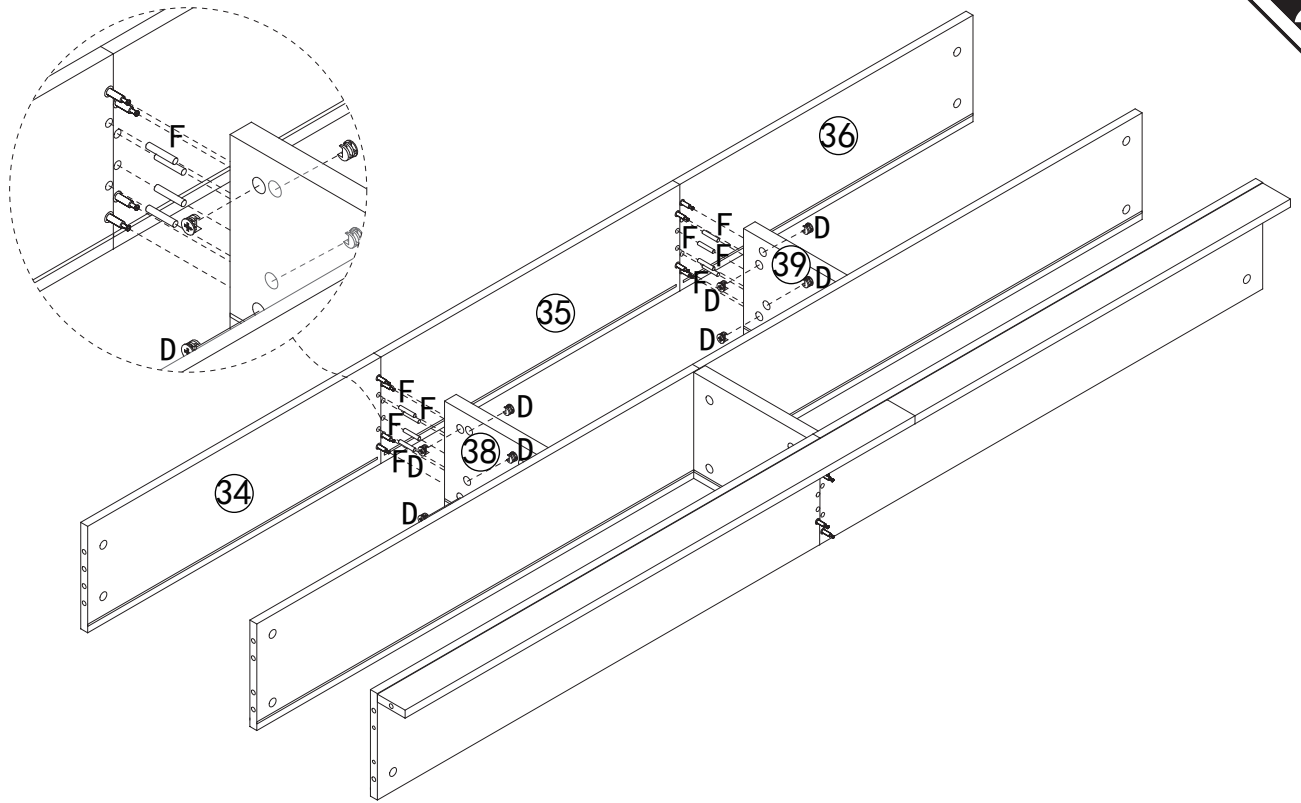

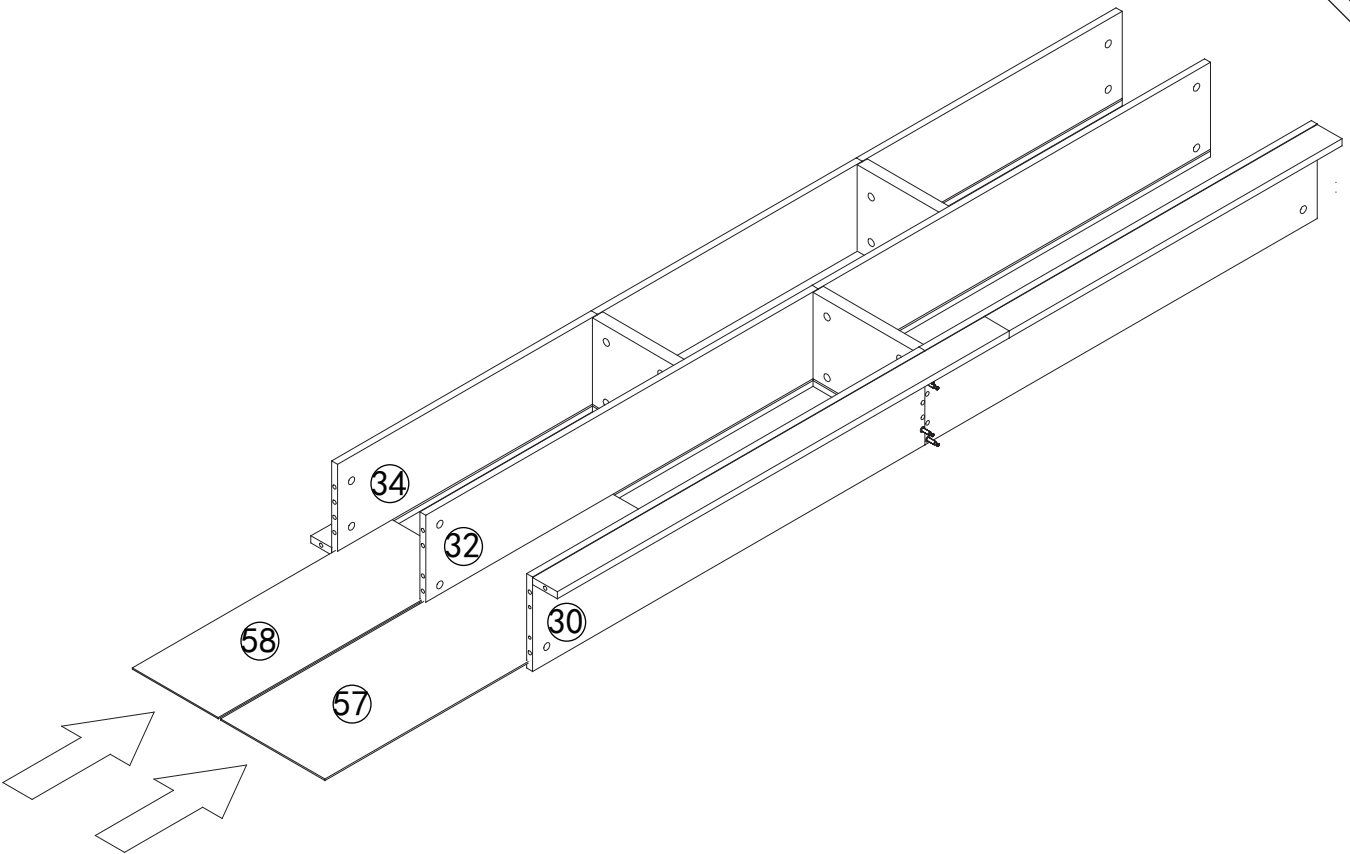
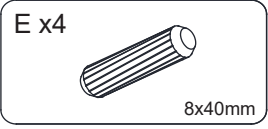
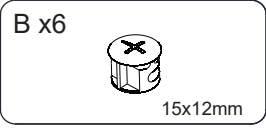
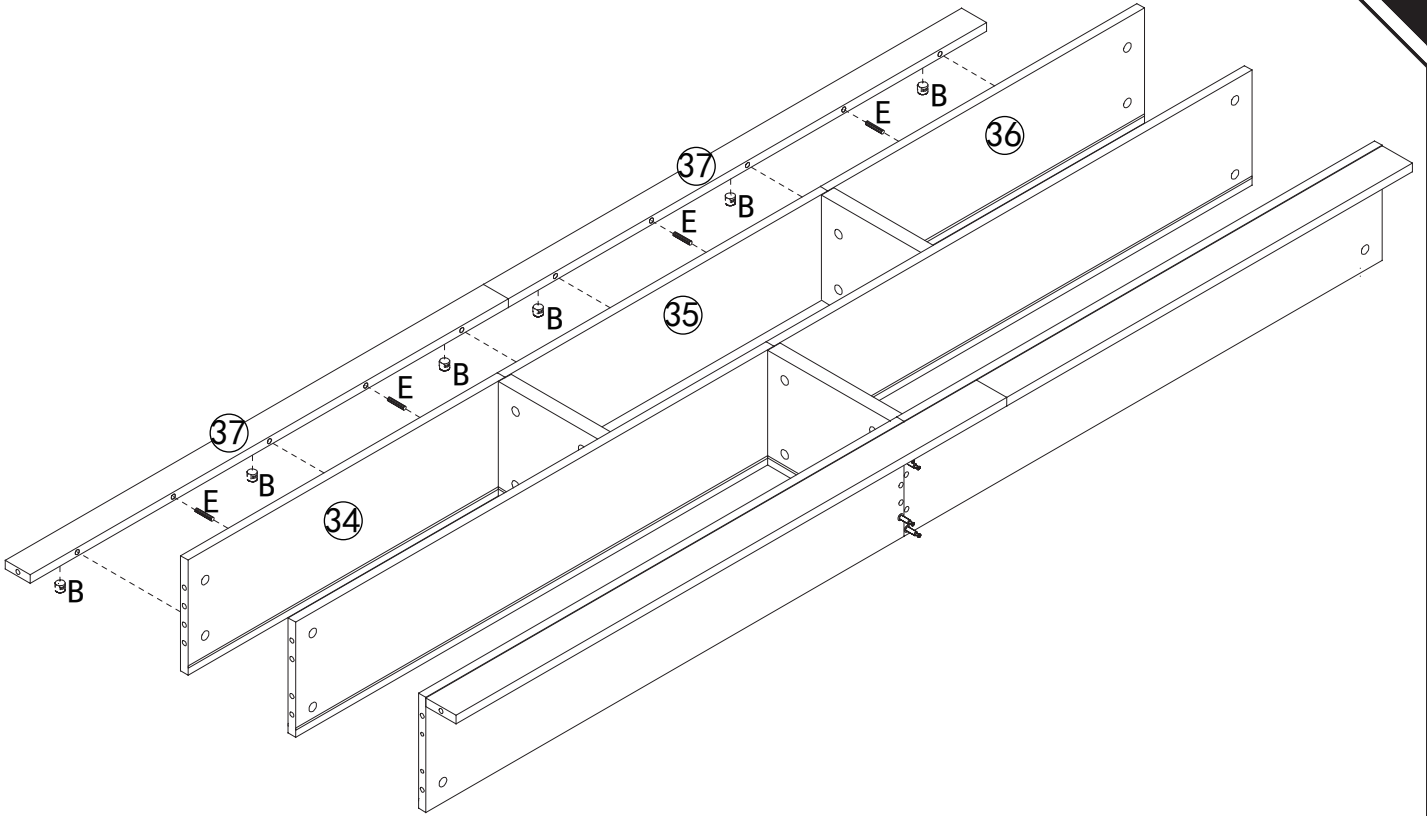

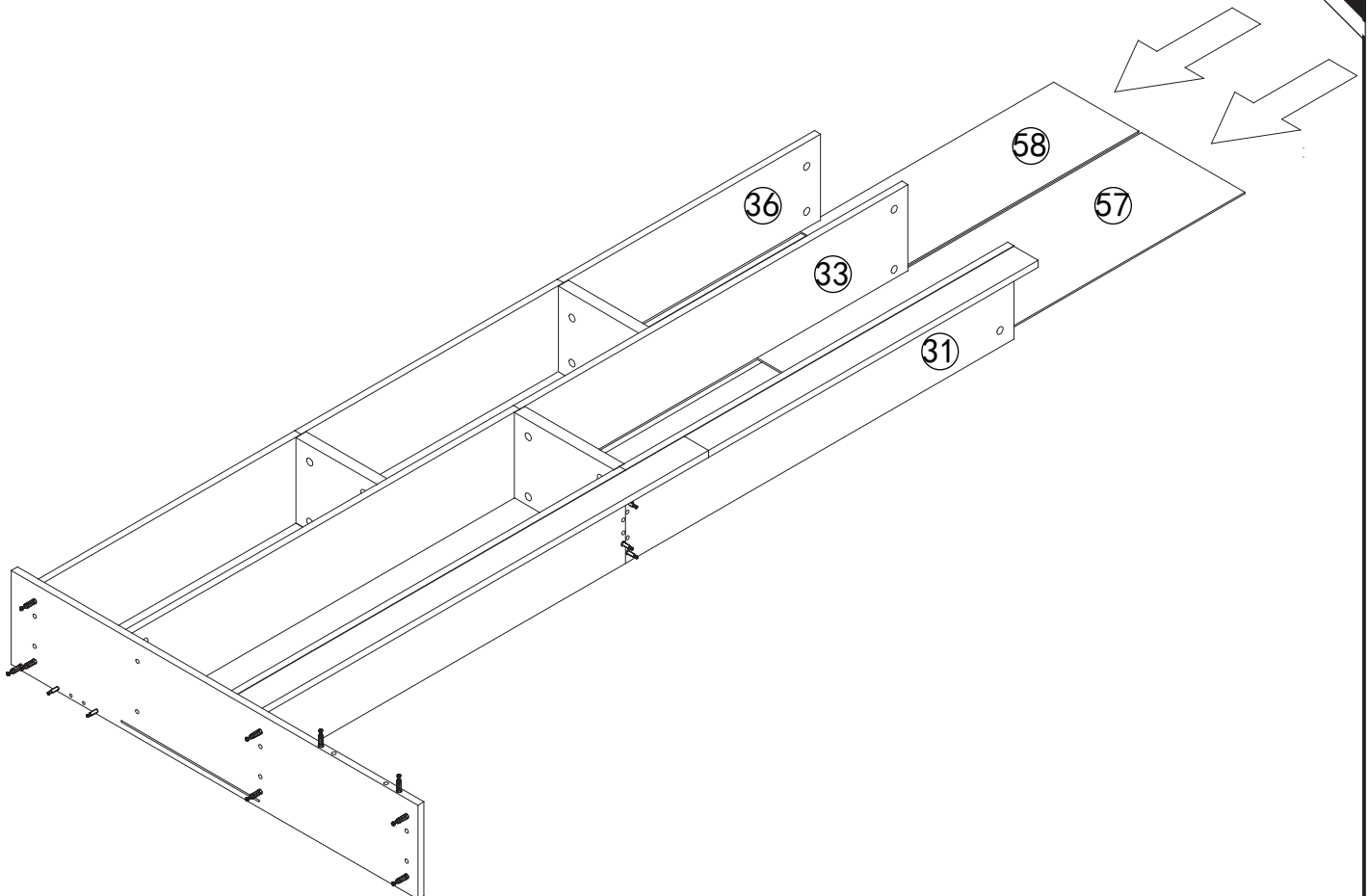
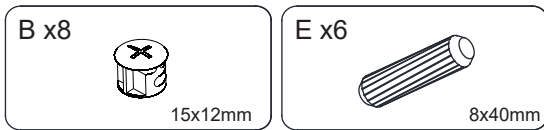
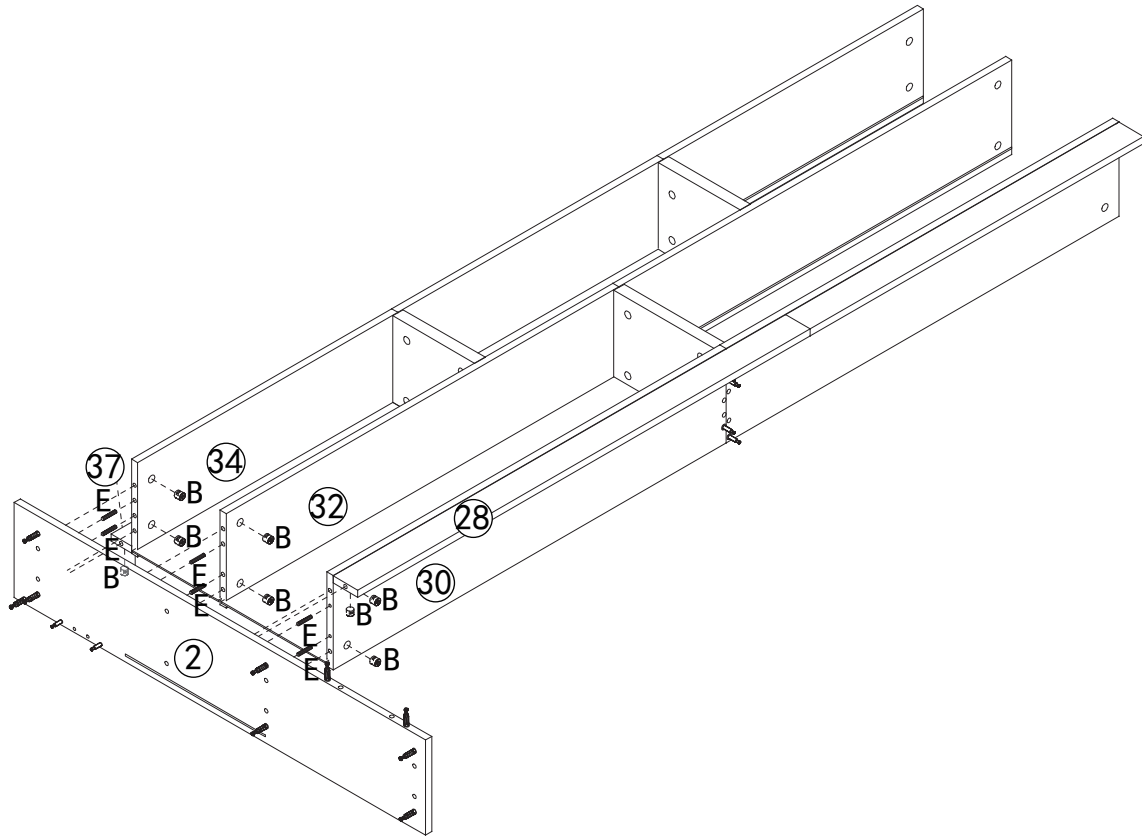

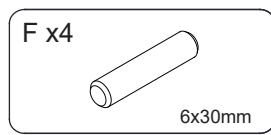
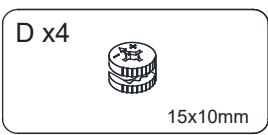
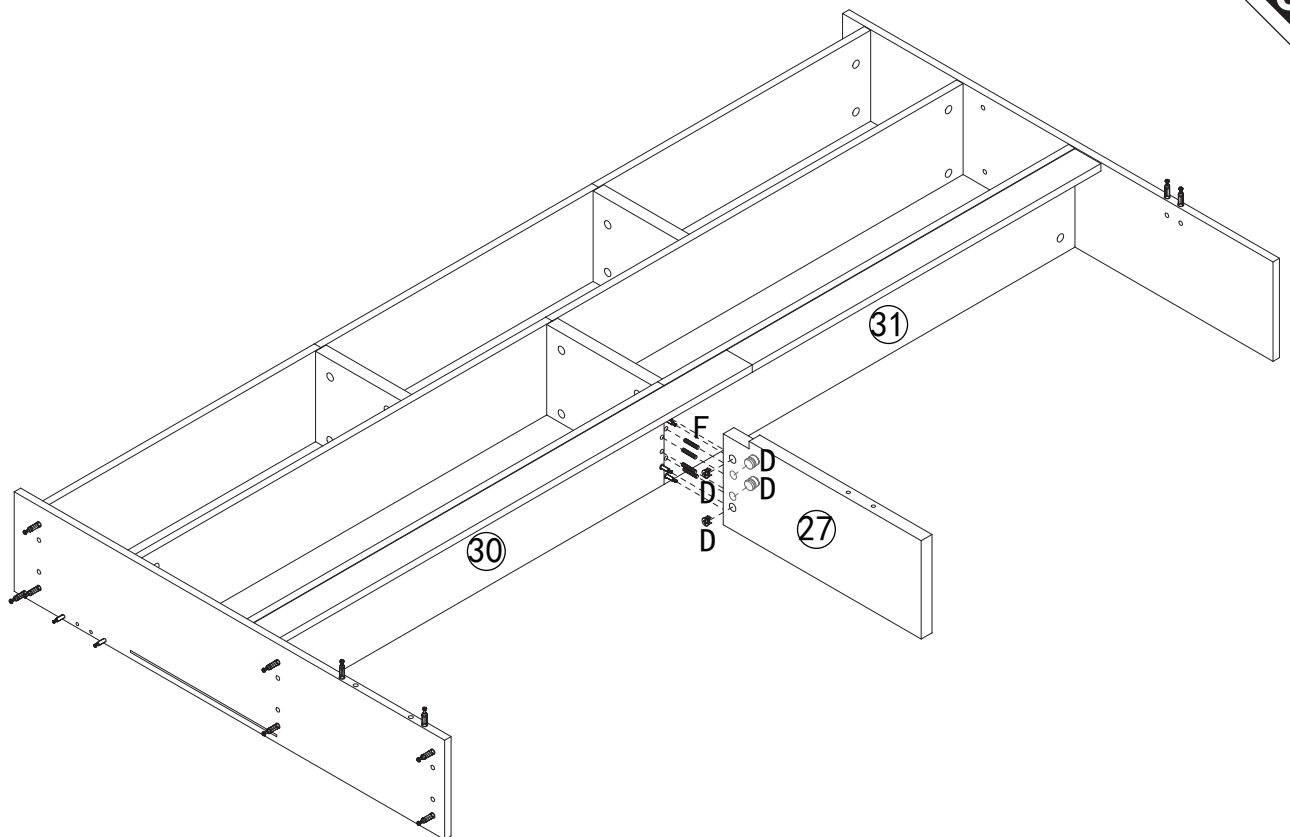
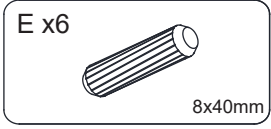
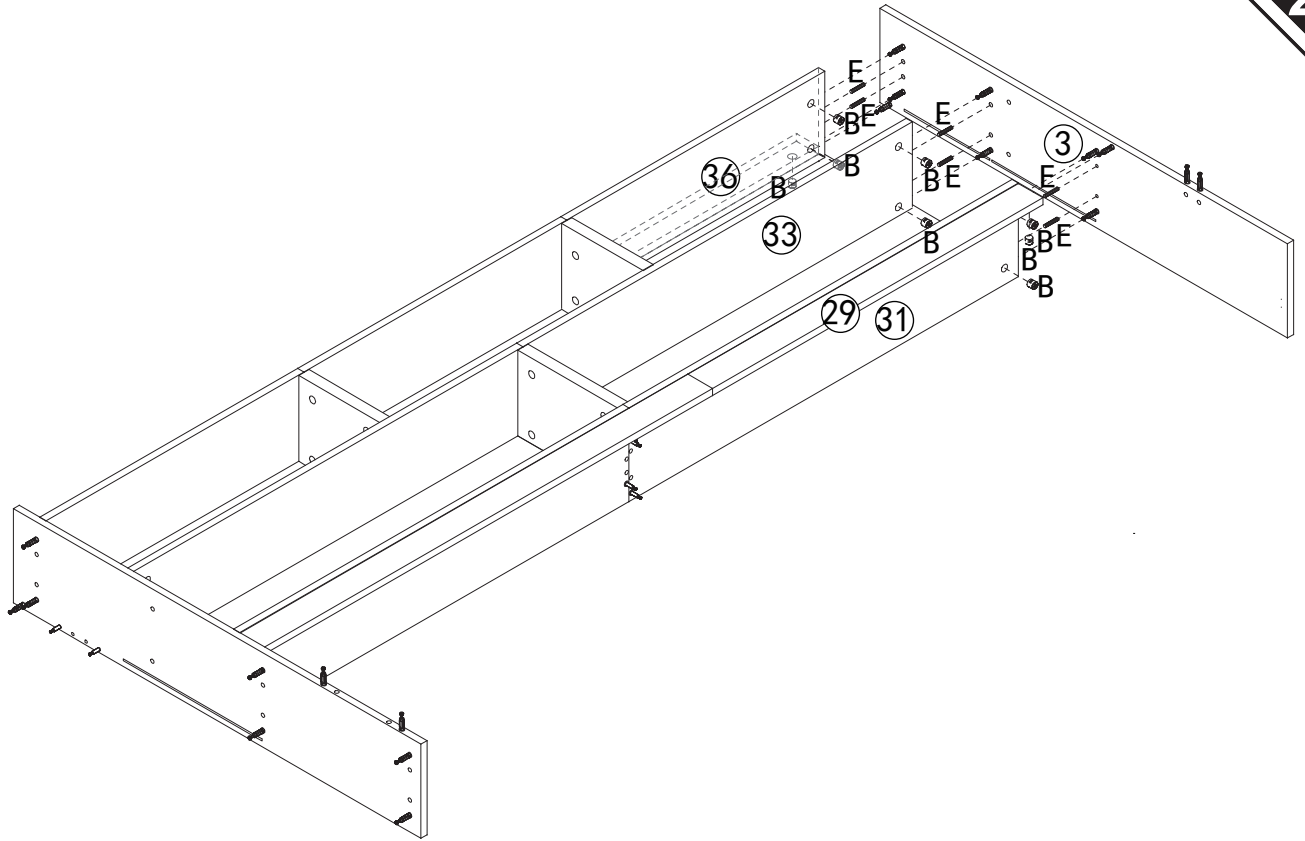

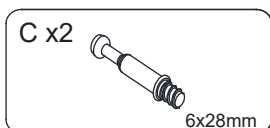
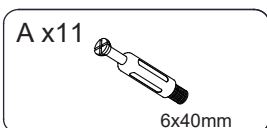
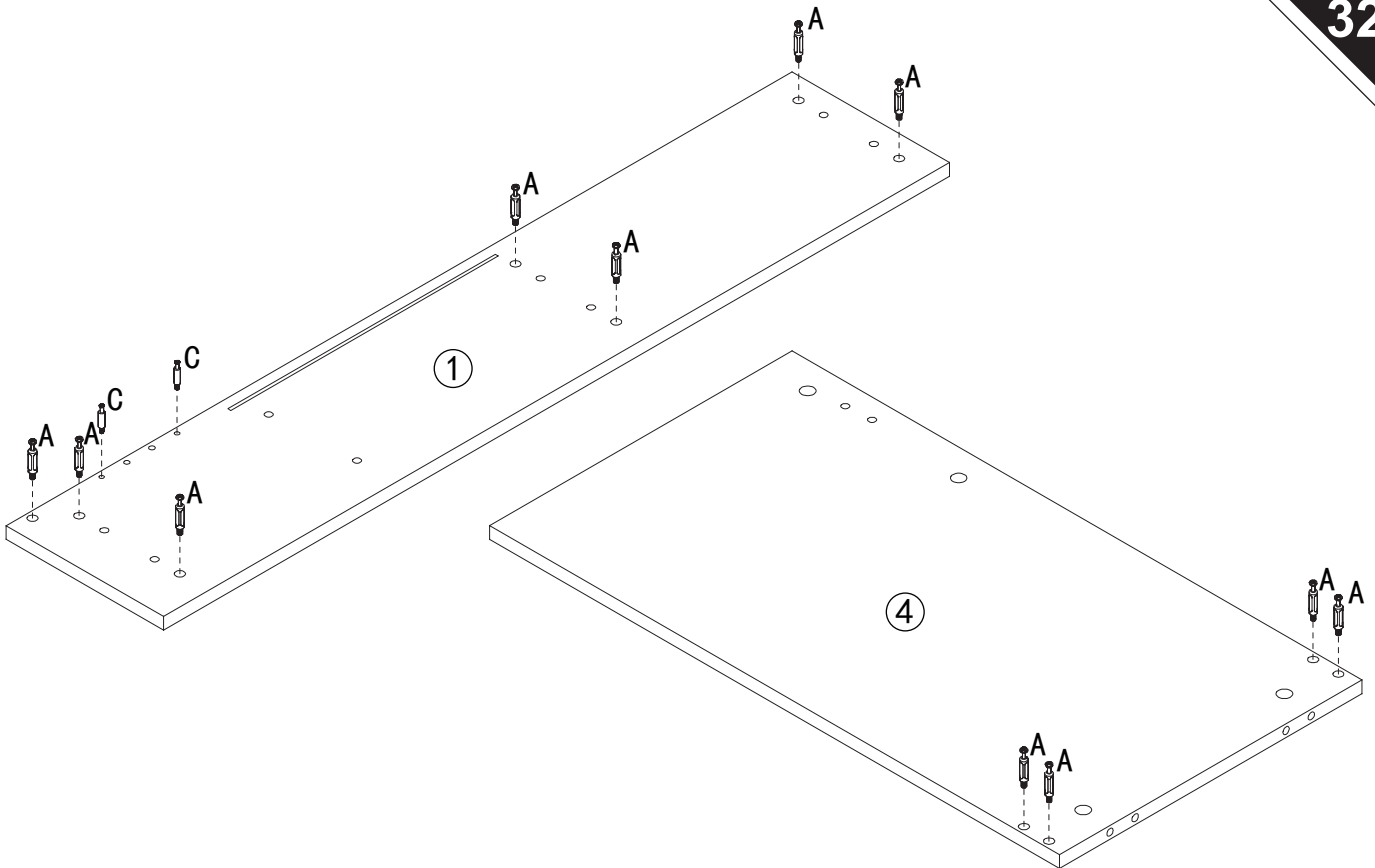
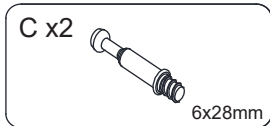
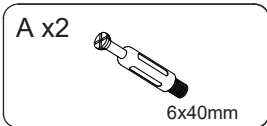
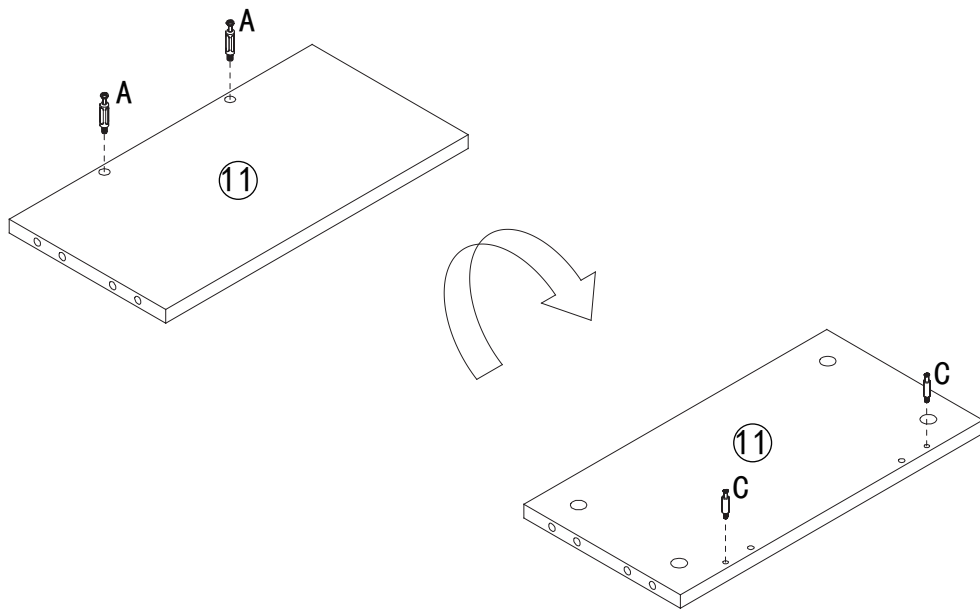

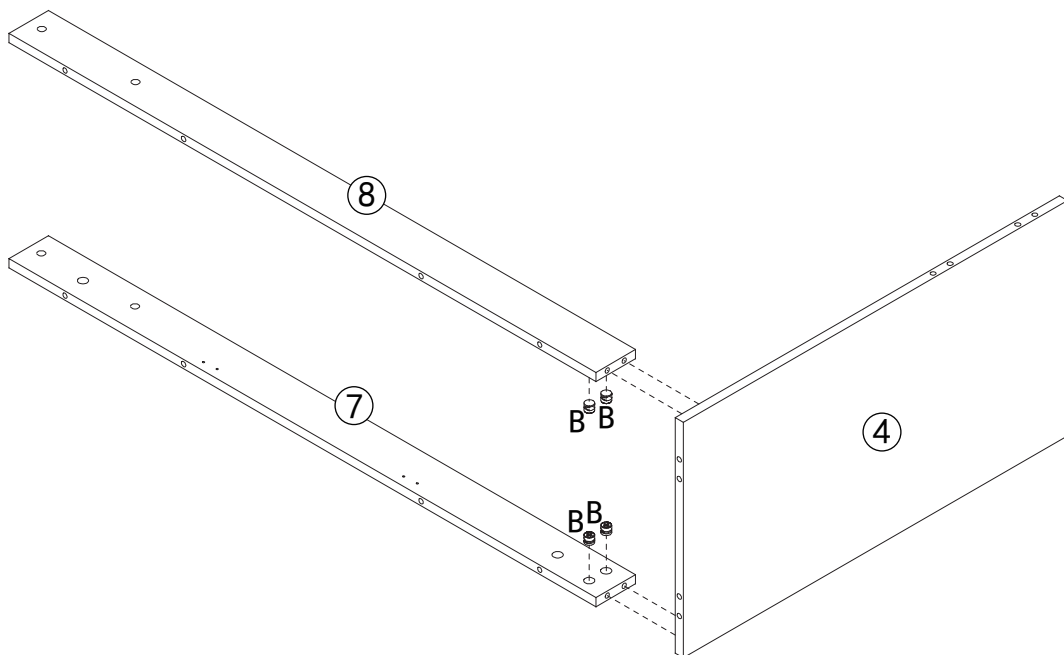
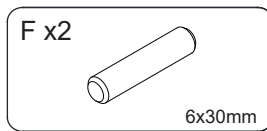
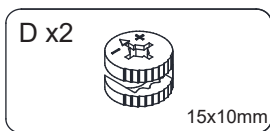
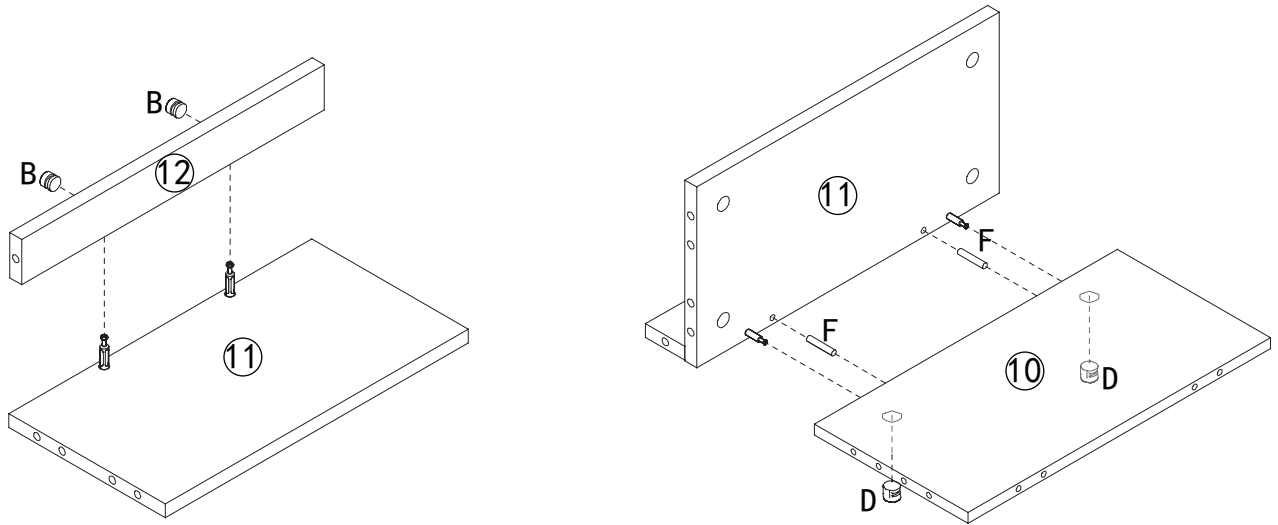

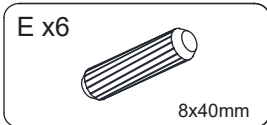
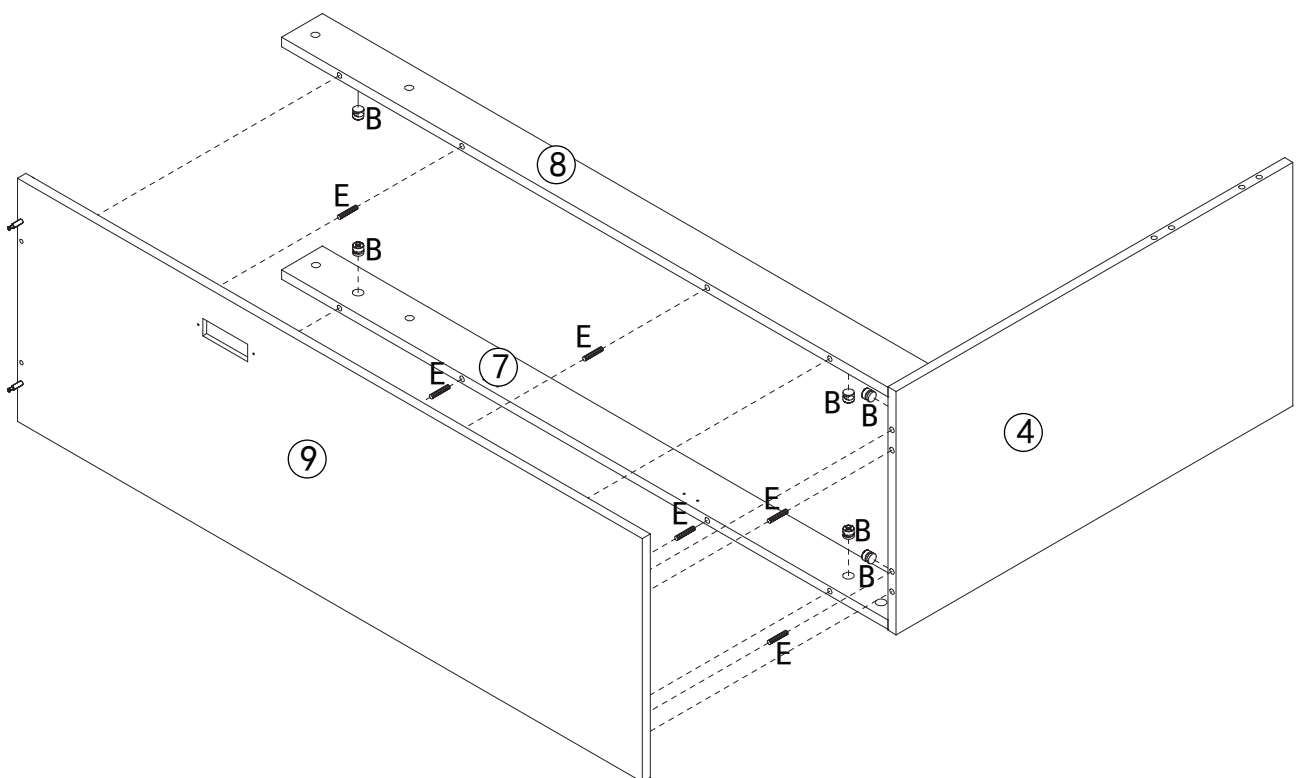
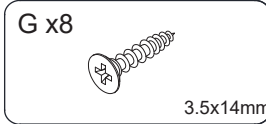
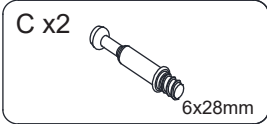
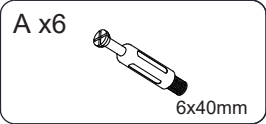
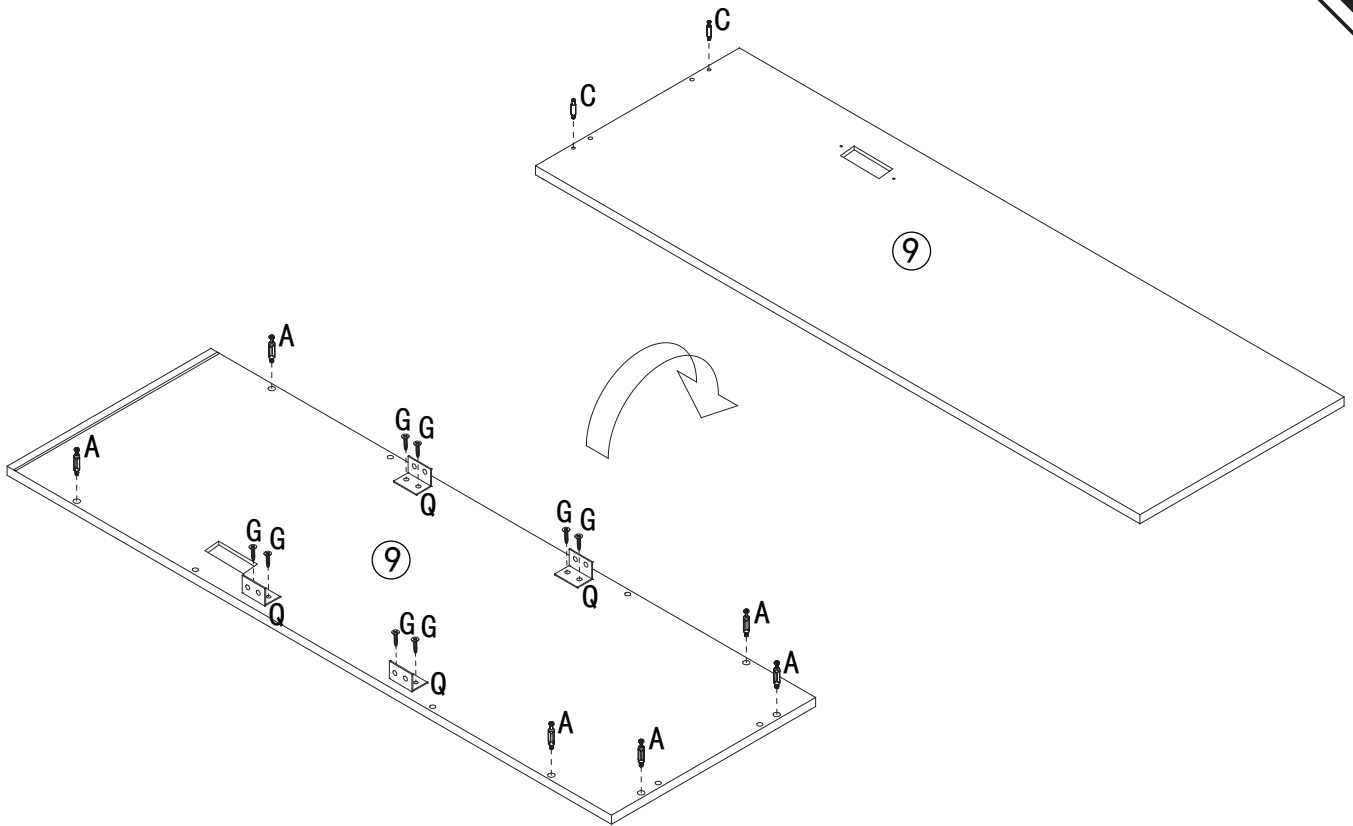

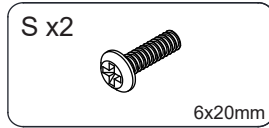
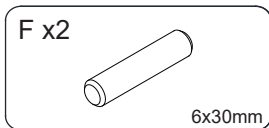
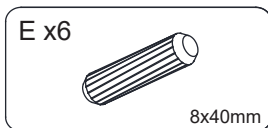
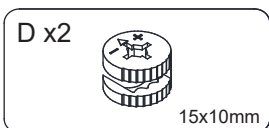
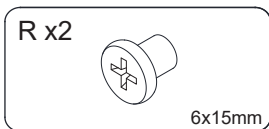
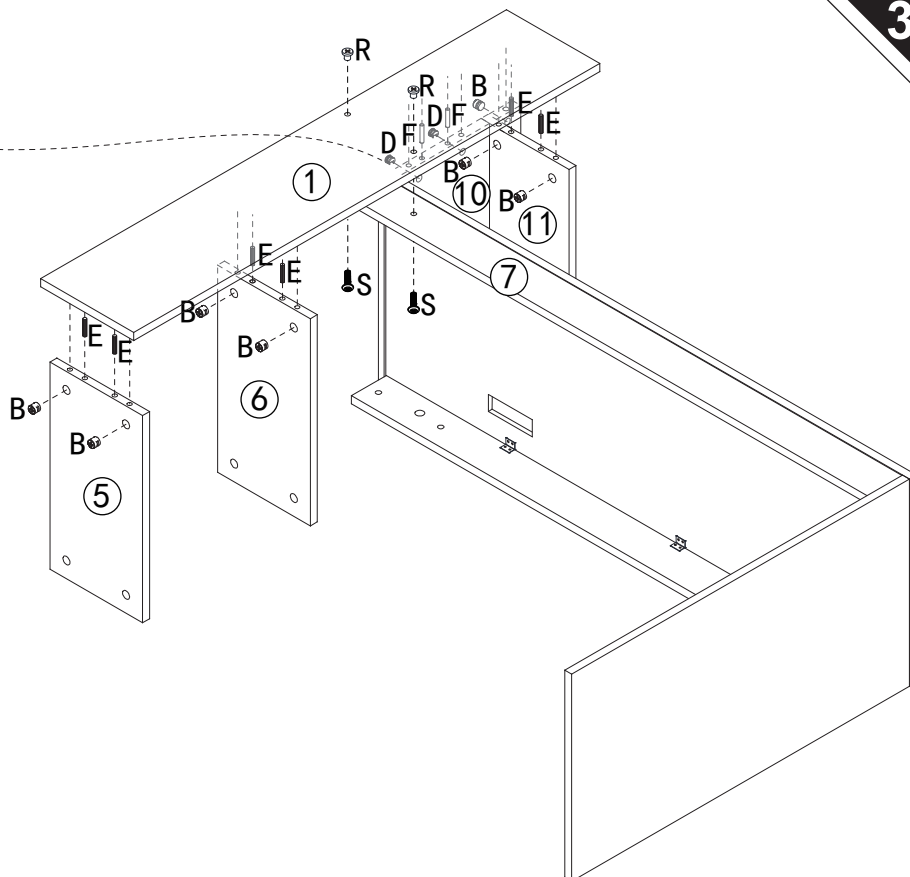
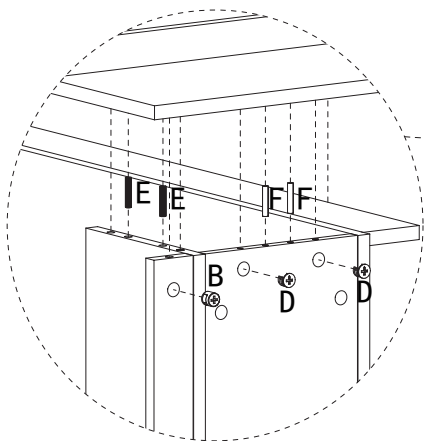
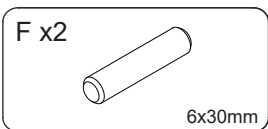
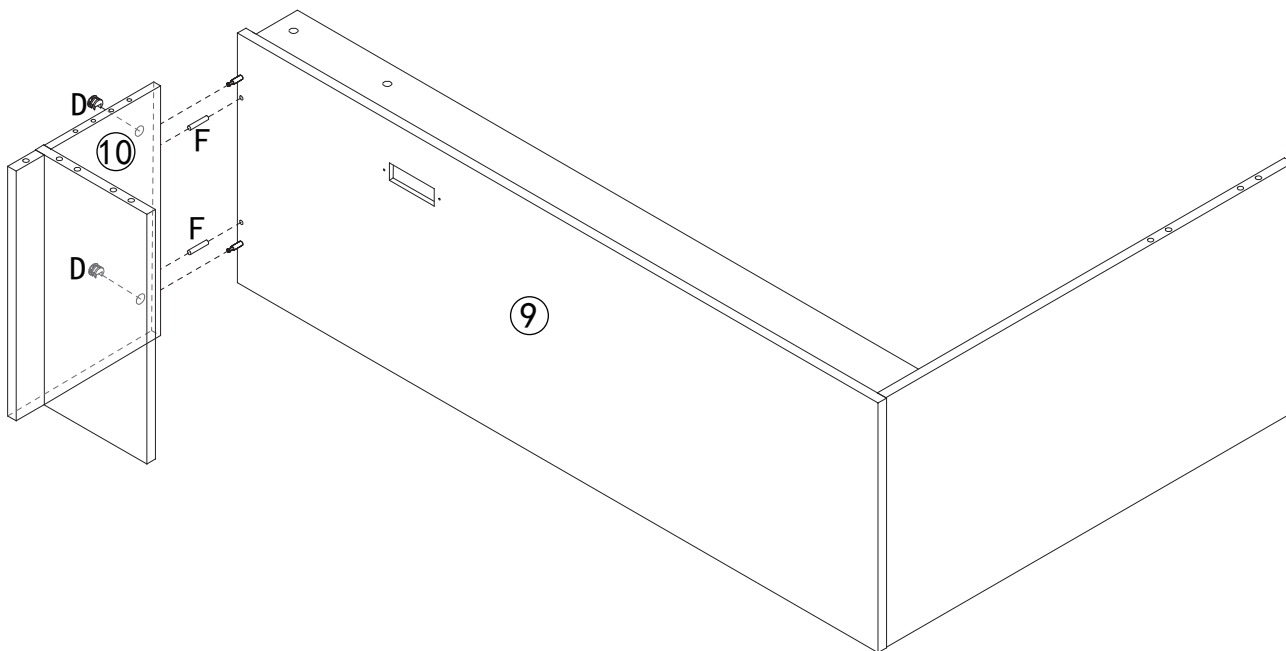

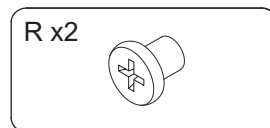
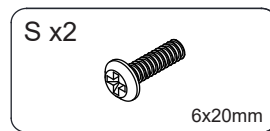
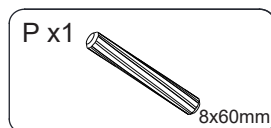
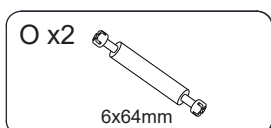
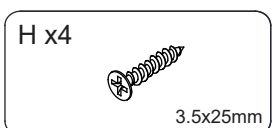
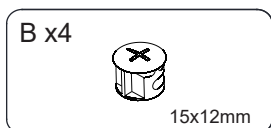
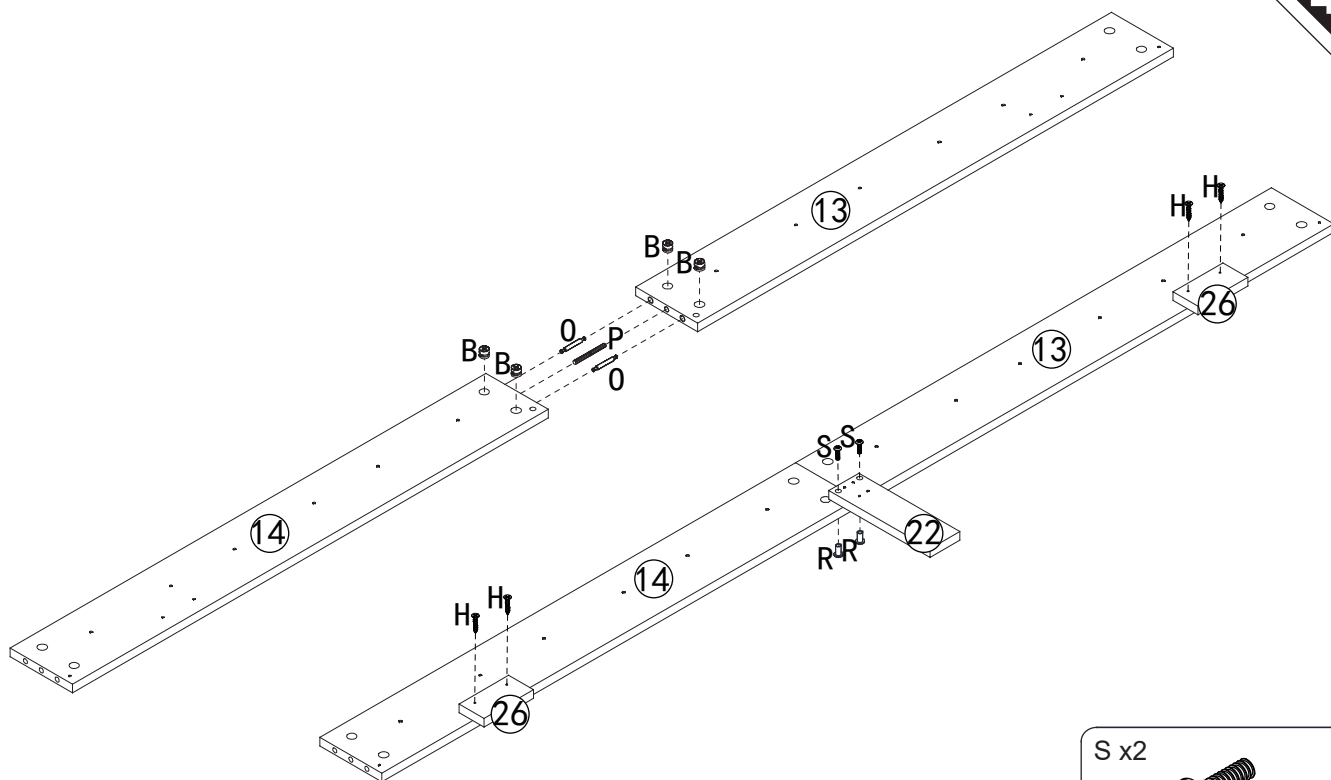
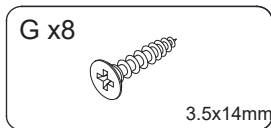
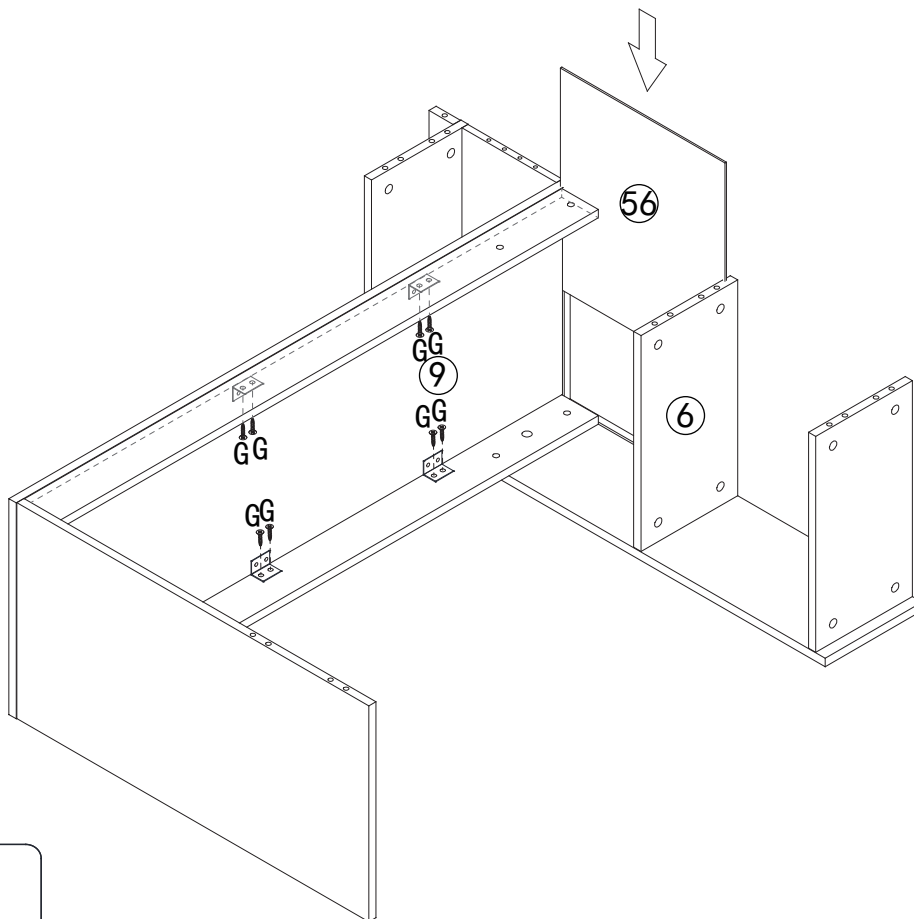

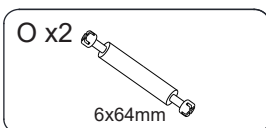
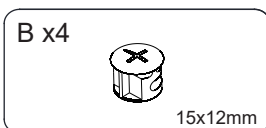
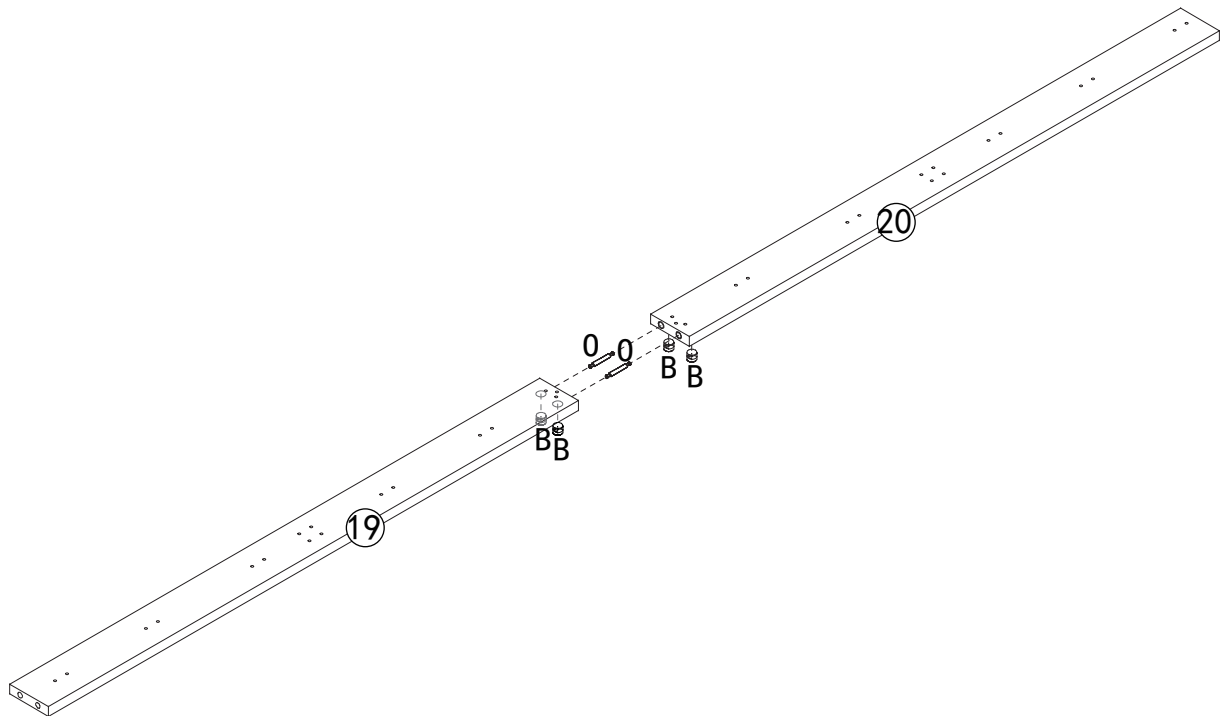
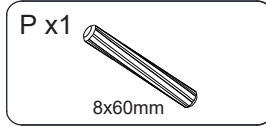
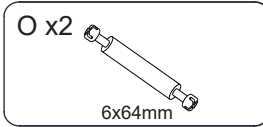
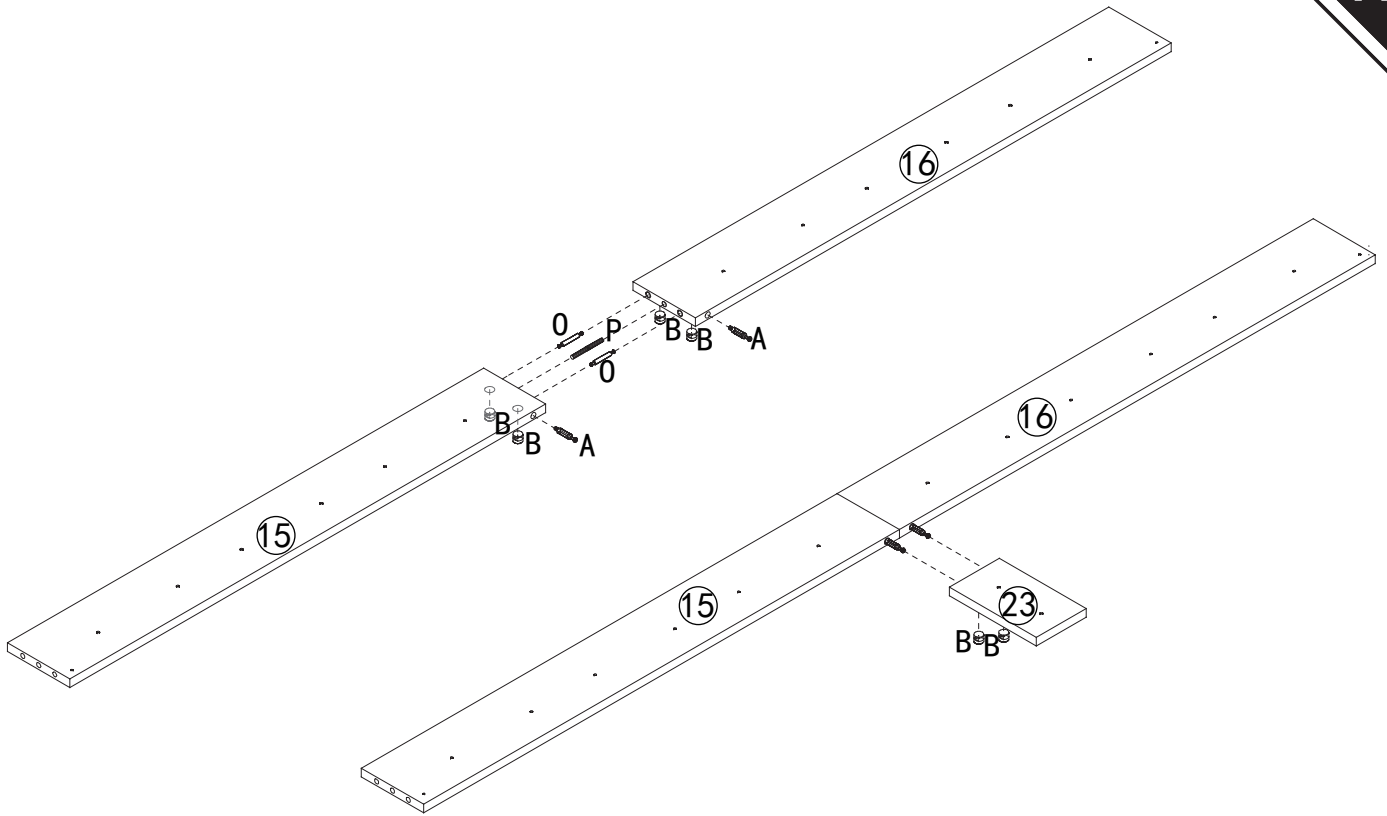

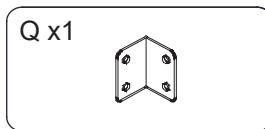
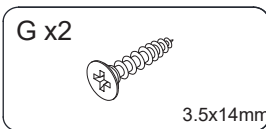
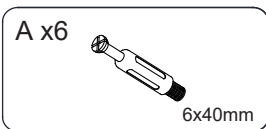
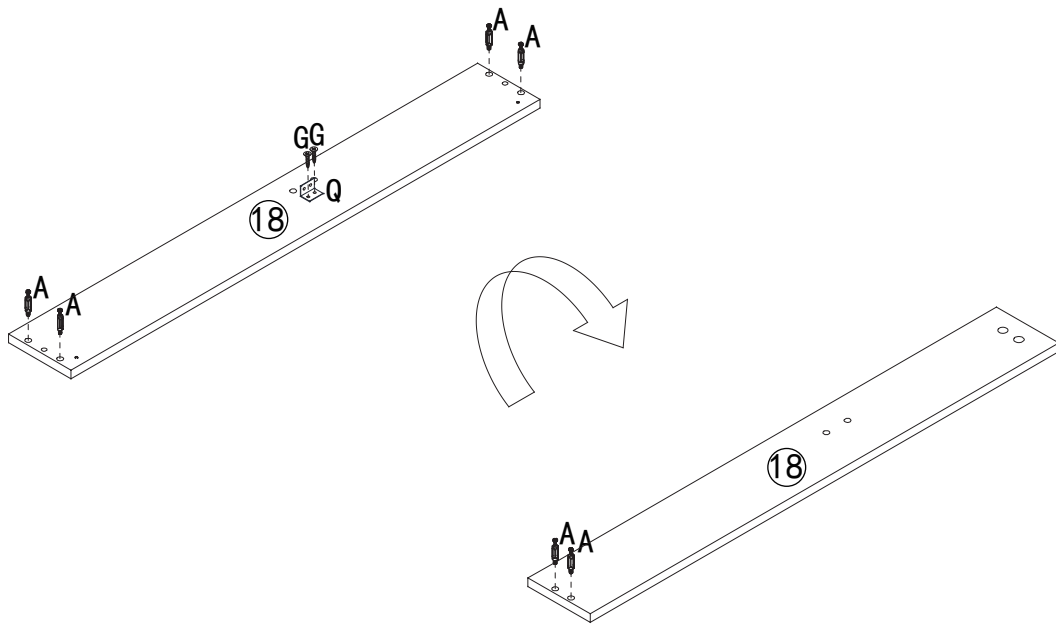
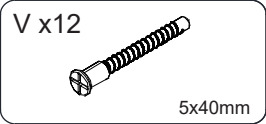
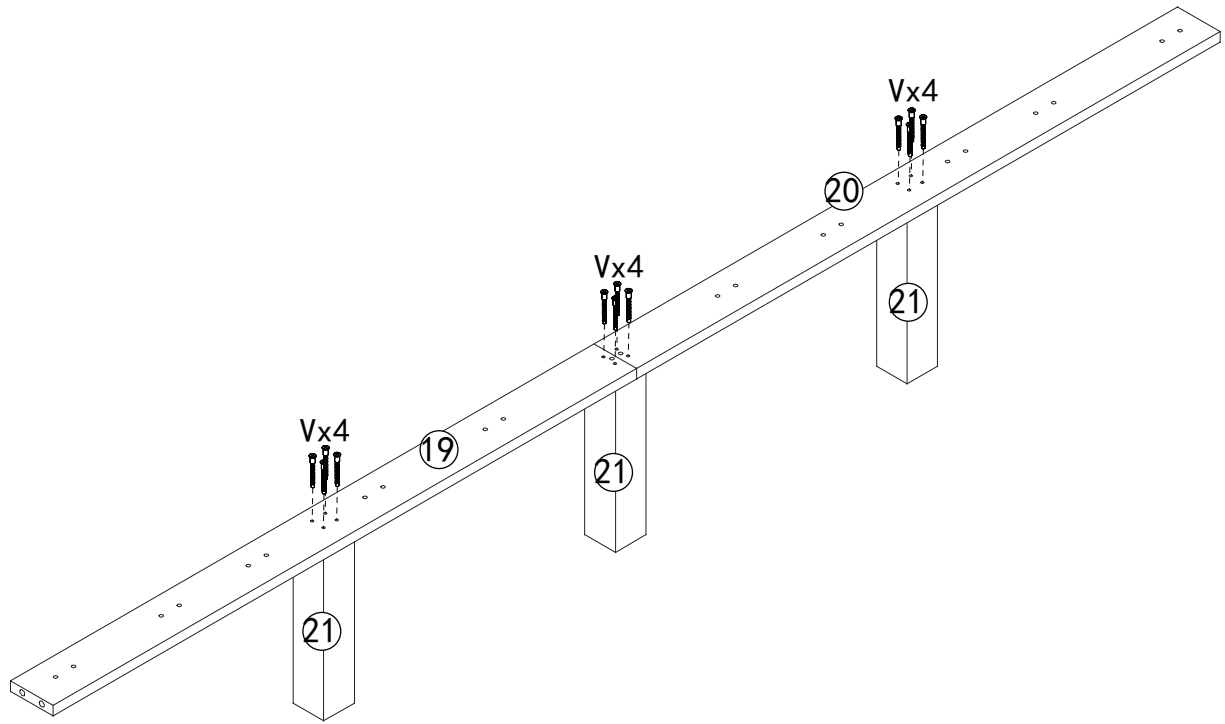

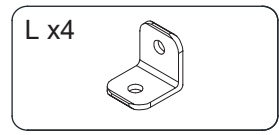
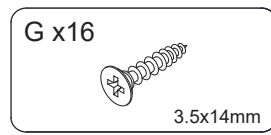
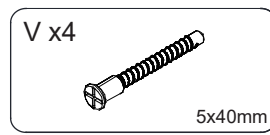
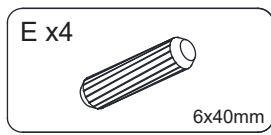
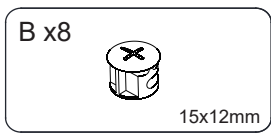
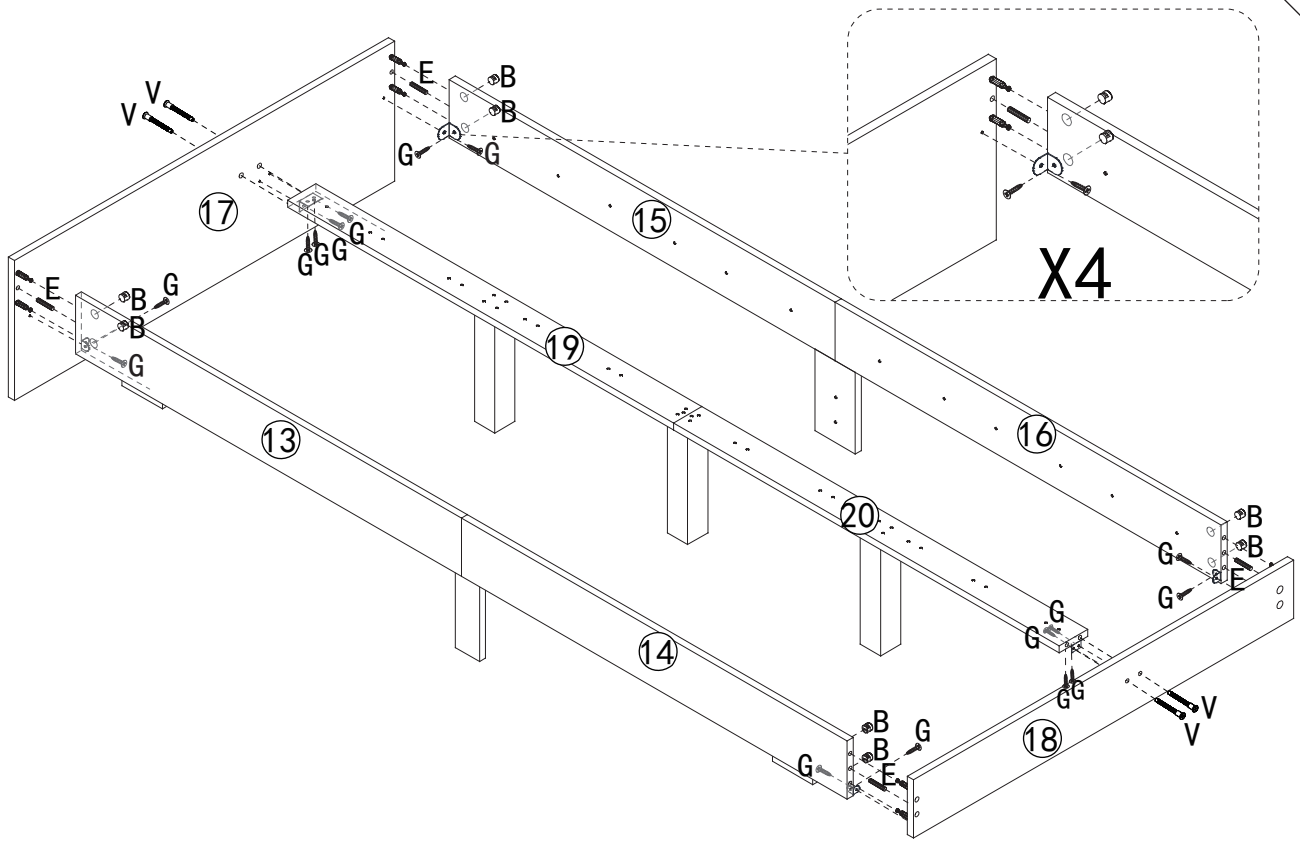
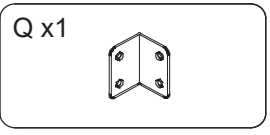
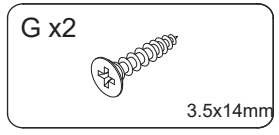
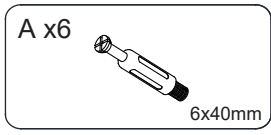
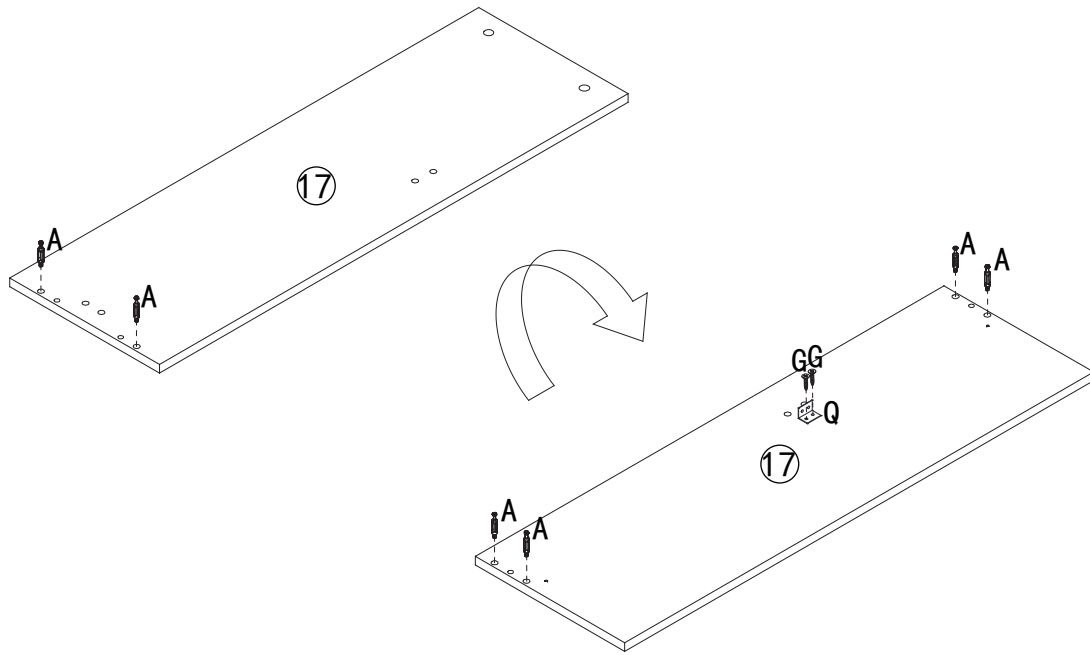

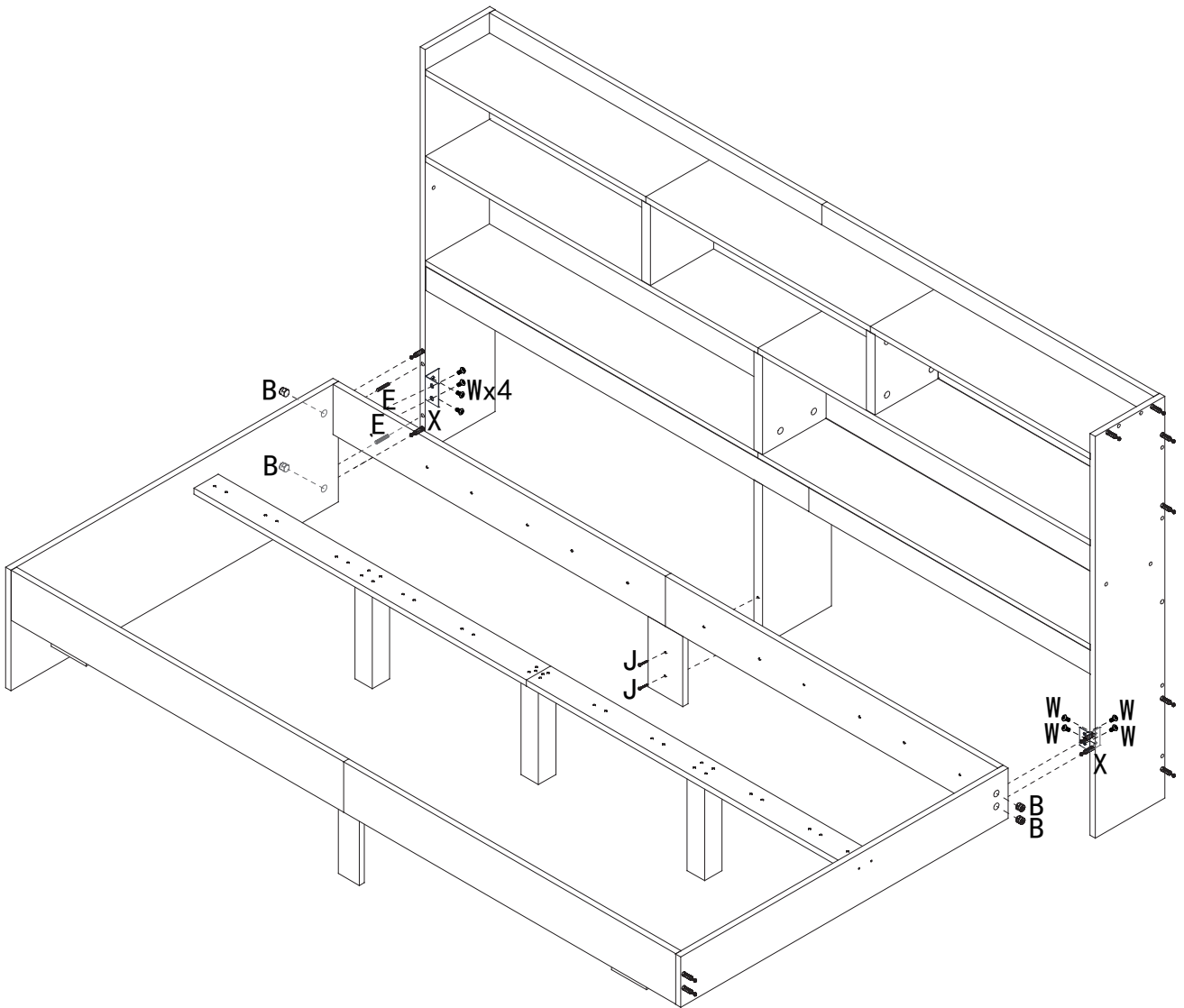



B x4



15x12mm

E x2

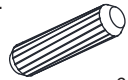

6x40mm

J x2

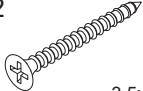

3.5x35mm

W x8



6x10mm

X x2



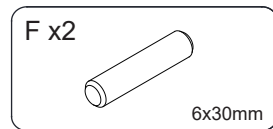
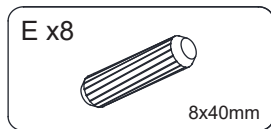
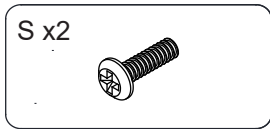
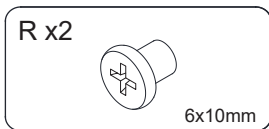
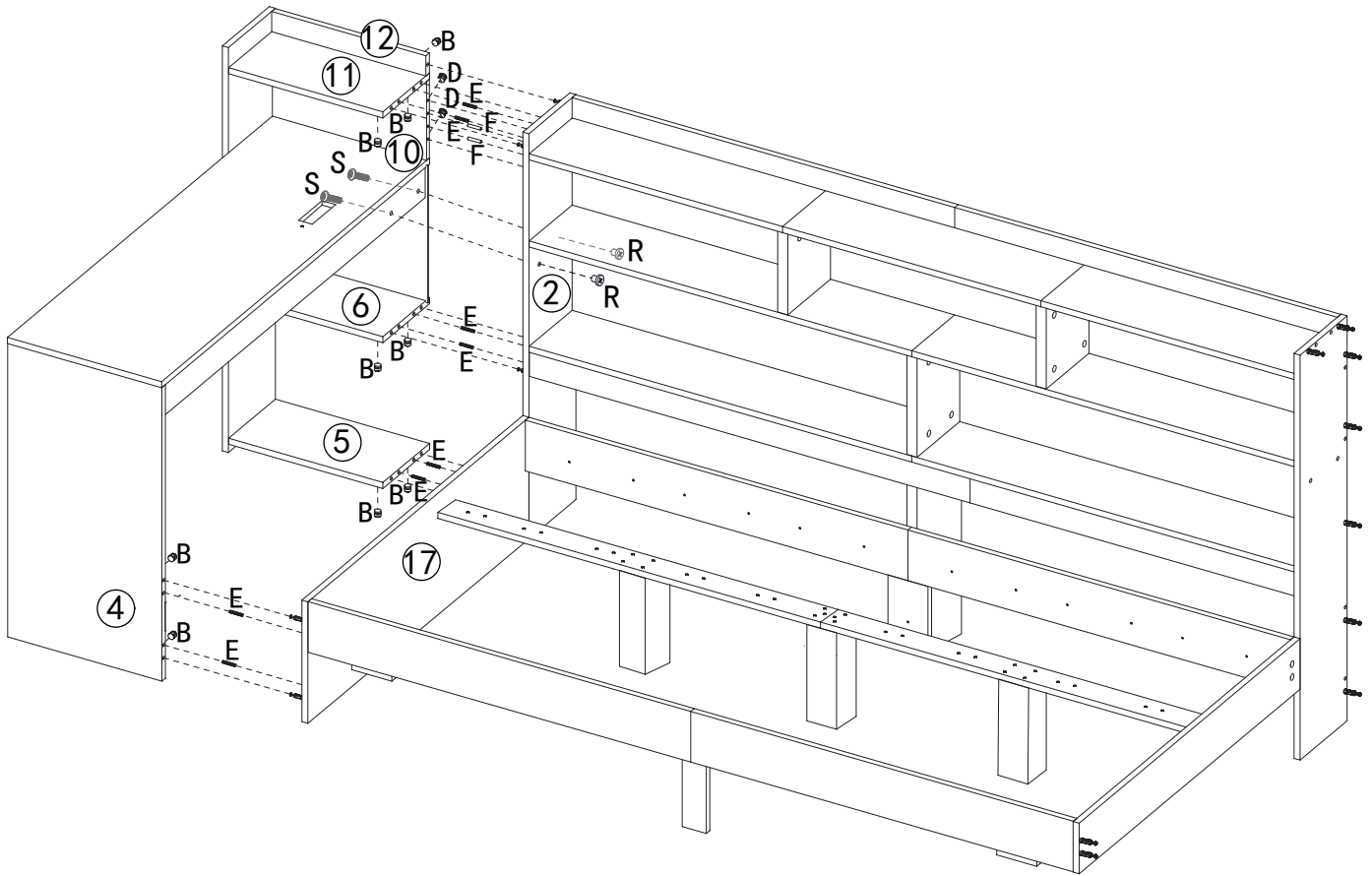

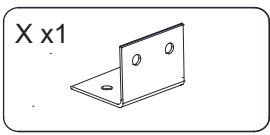
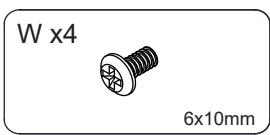
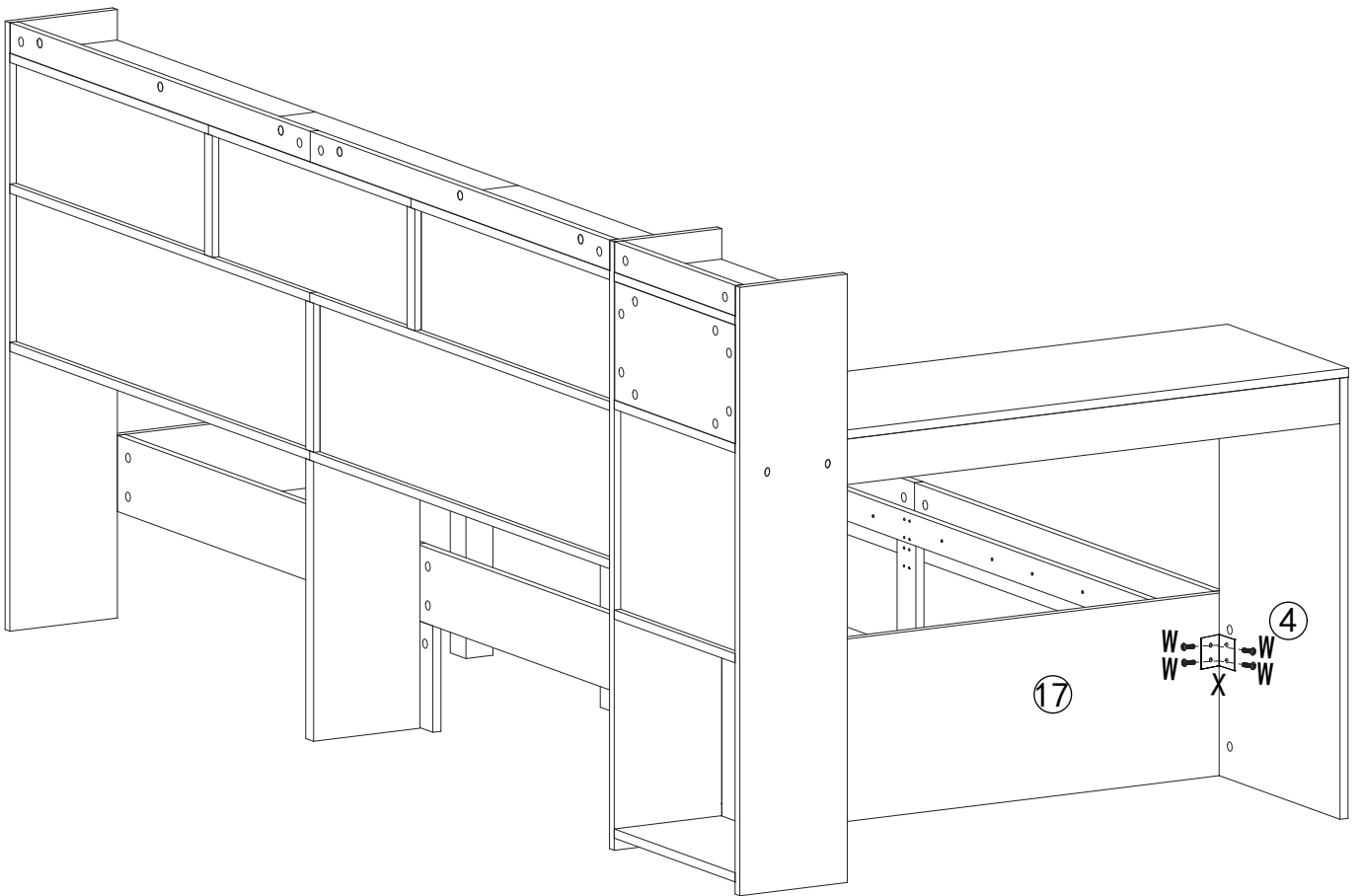

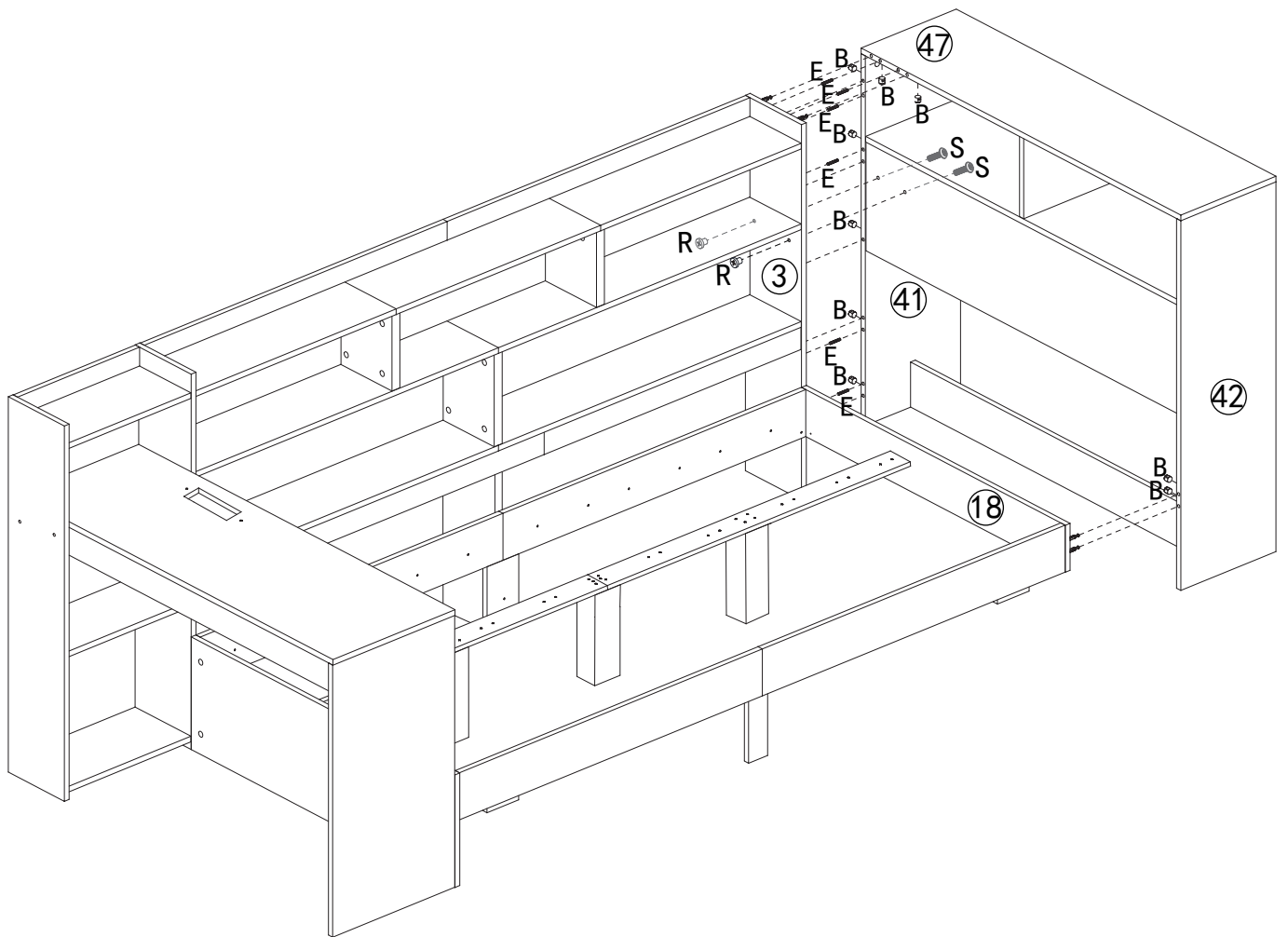

B x9



15x12mm

E x6



8x40mm

R x2



6x15mm

S x2



6x20mm

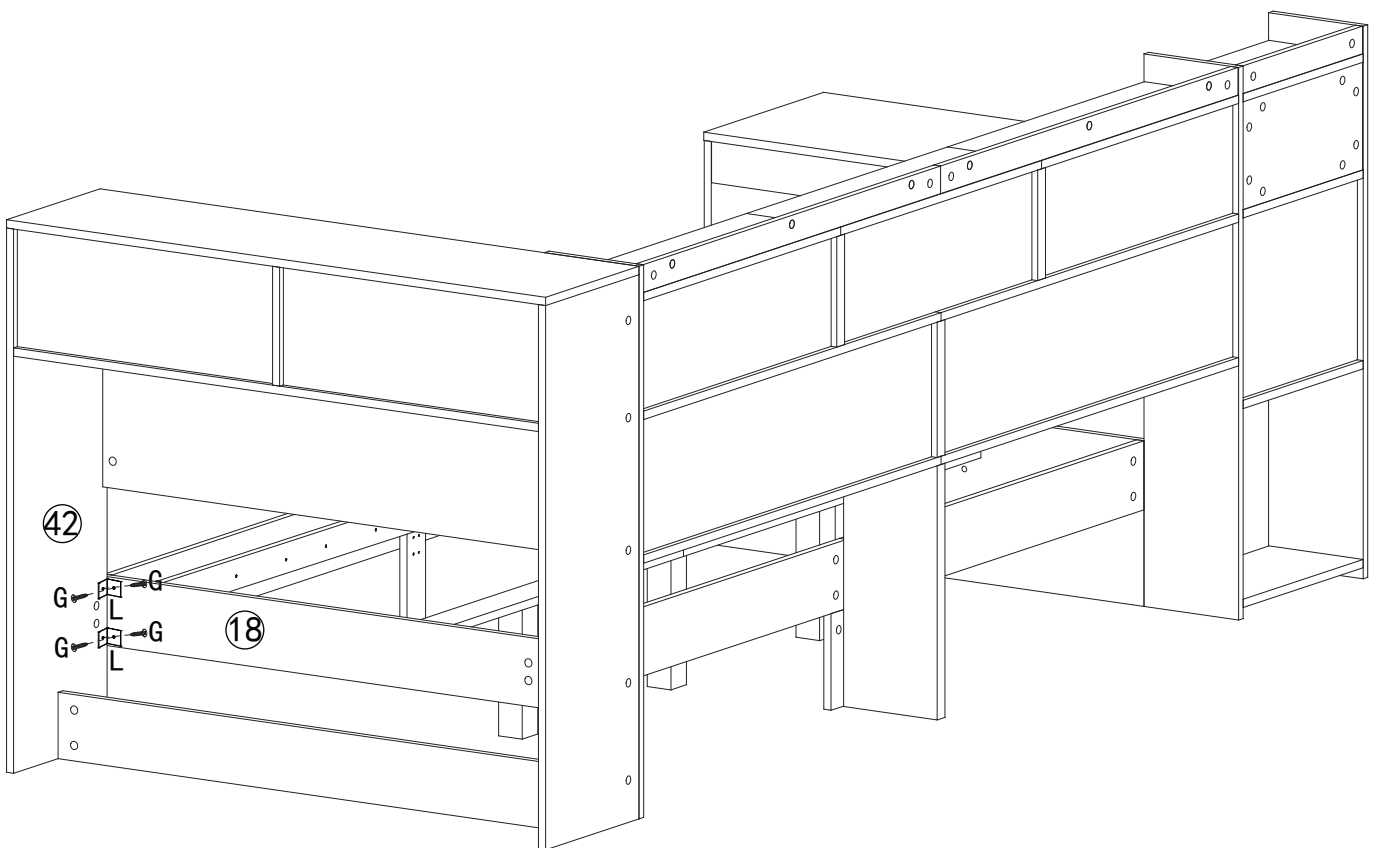

G x4



3.5x14mm

L x2



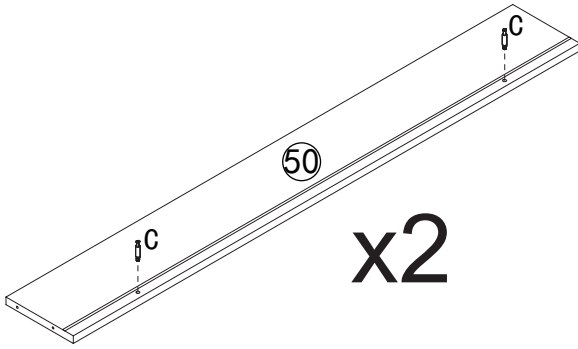

x2

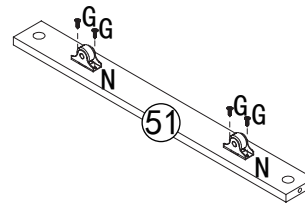

x4

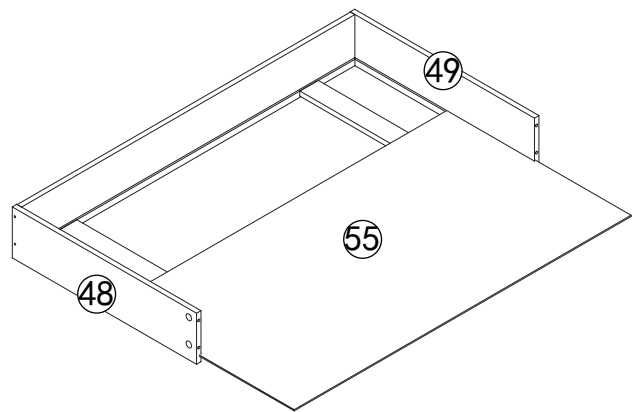
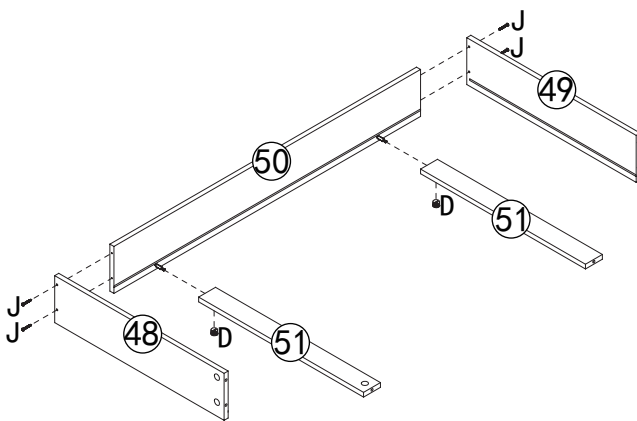
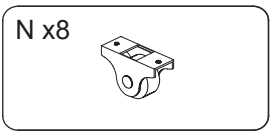
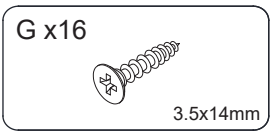
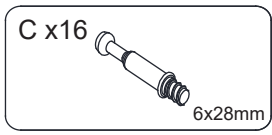
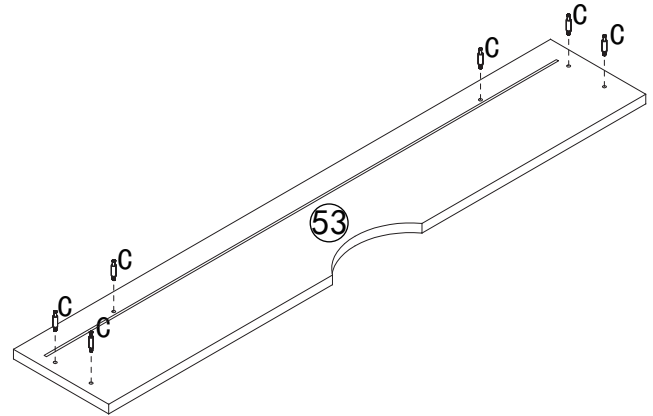
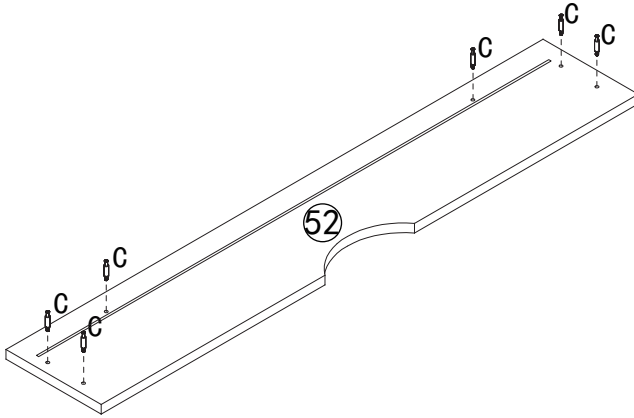

x2

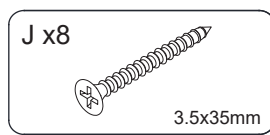
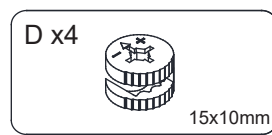

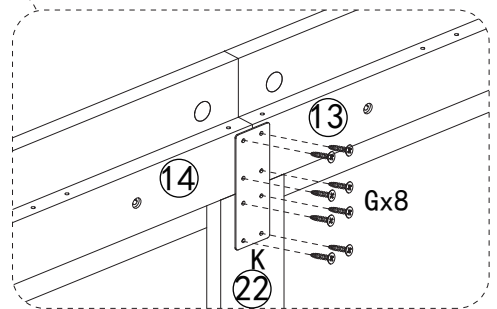
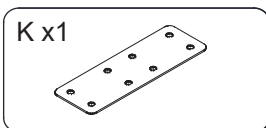
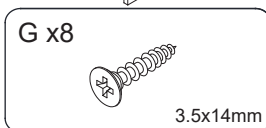
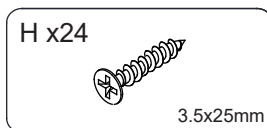
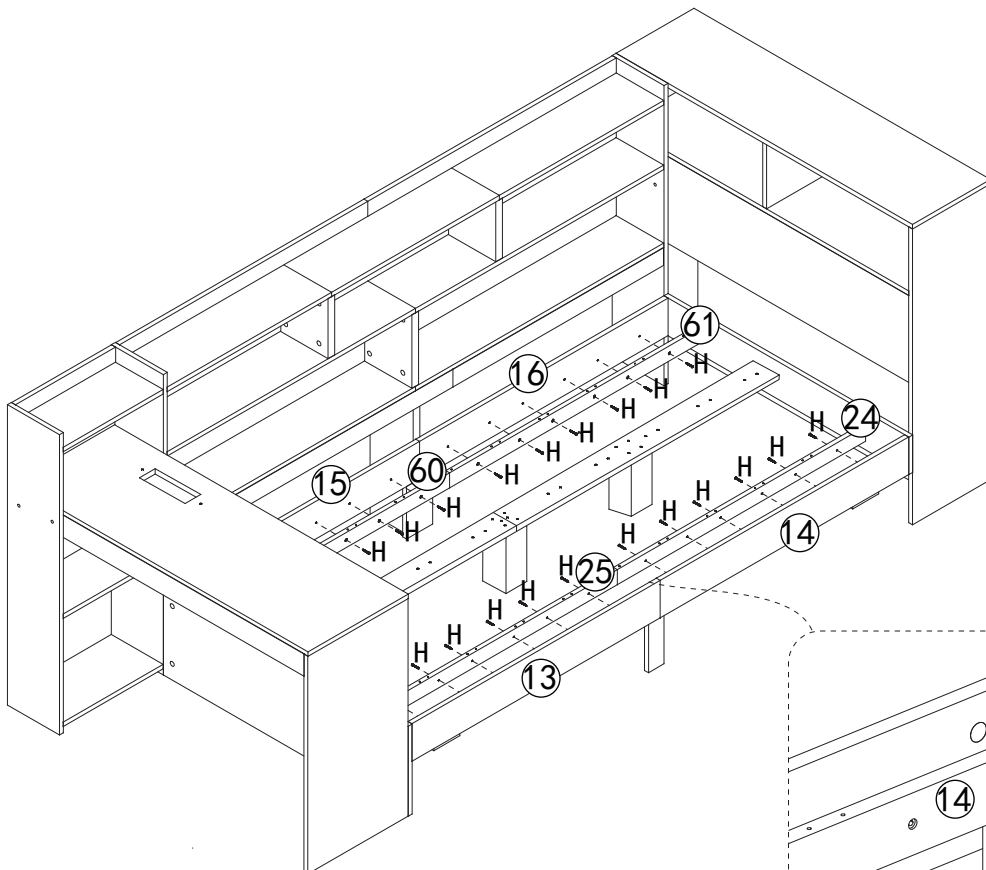
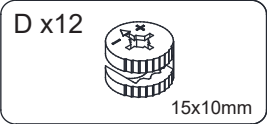
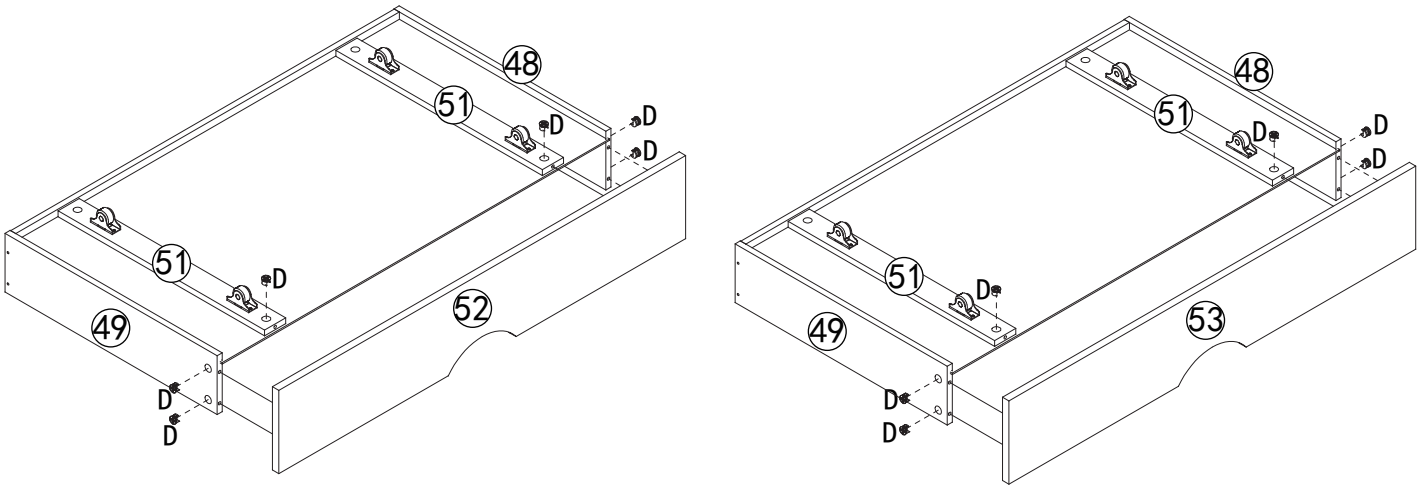

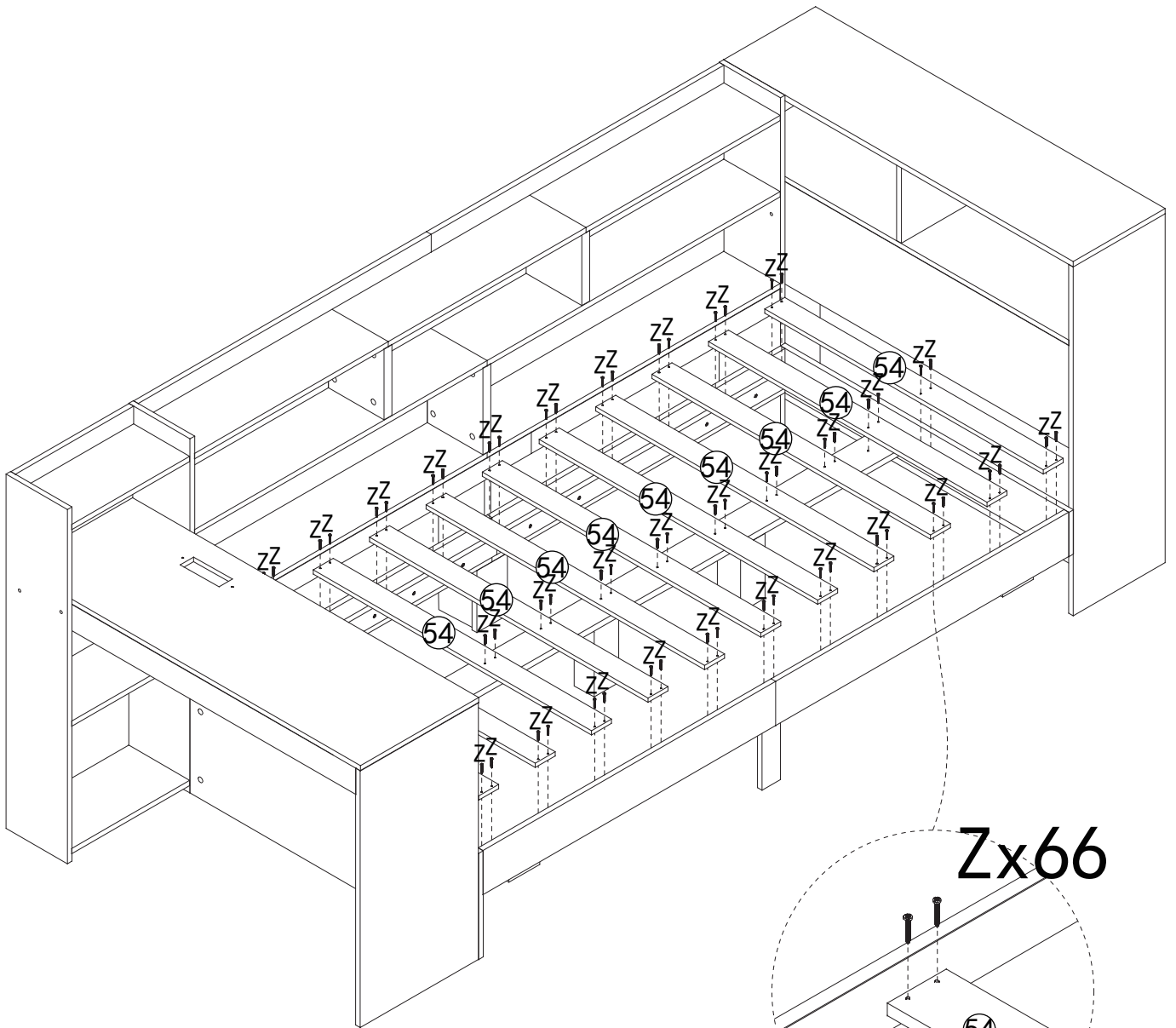

Zx66

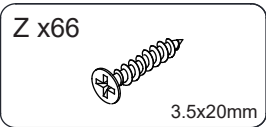

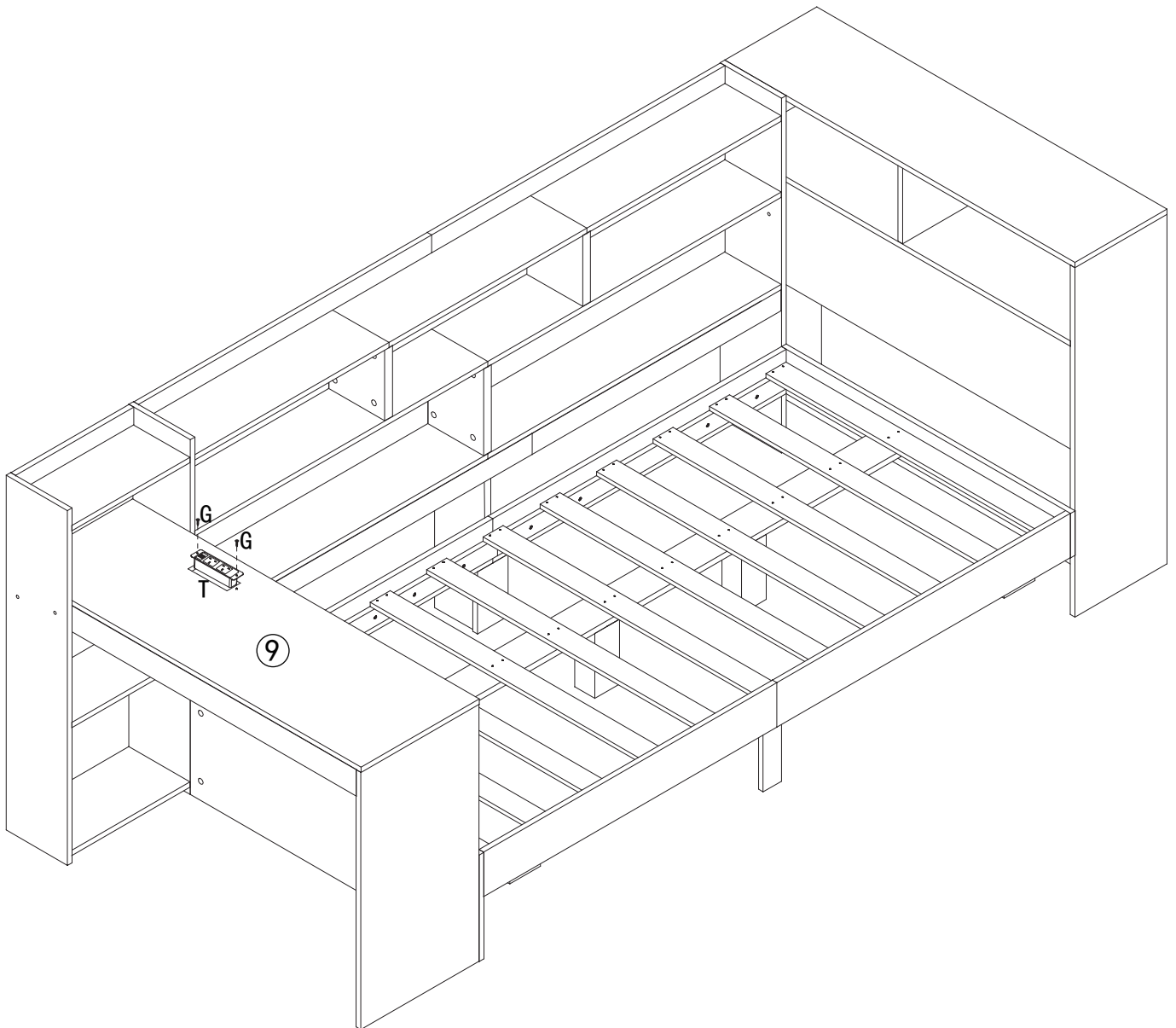

G x2



3.5x14mm

T x1



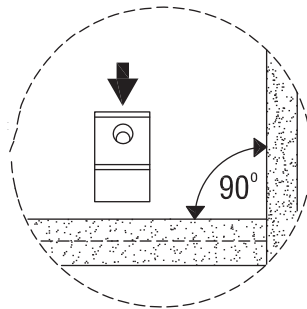
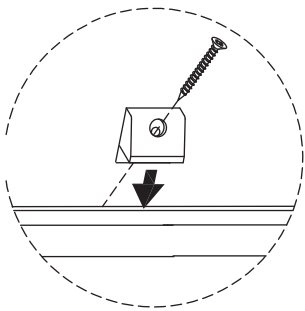
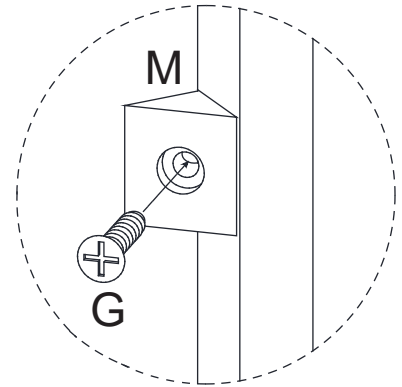
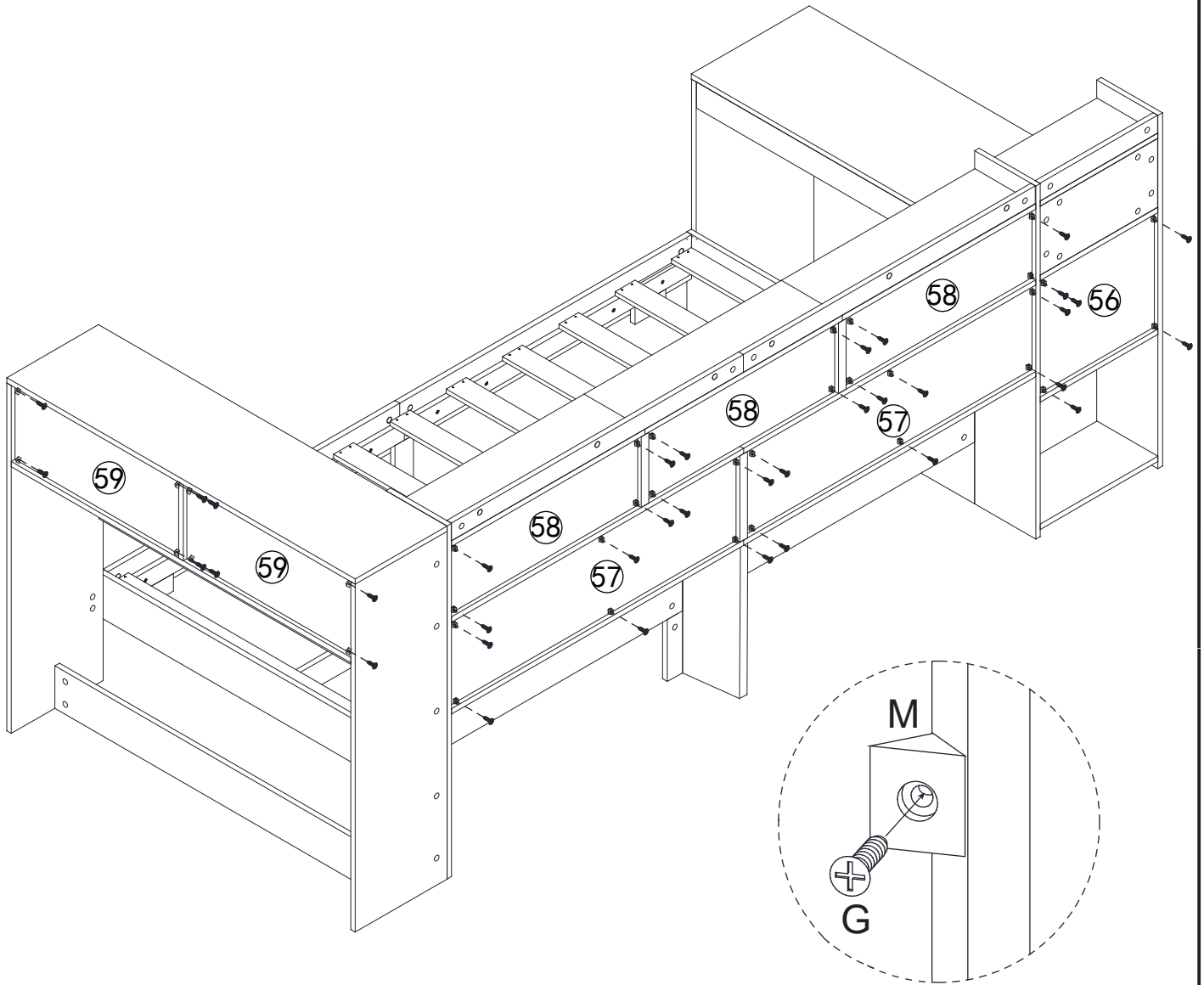

G x 36



3.5x14mm

M x 36



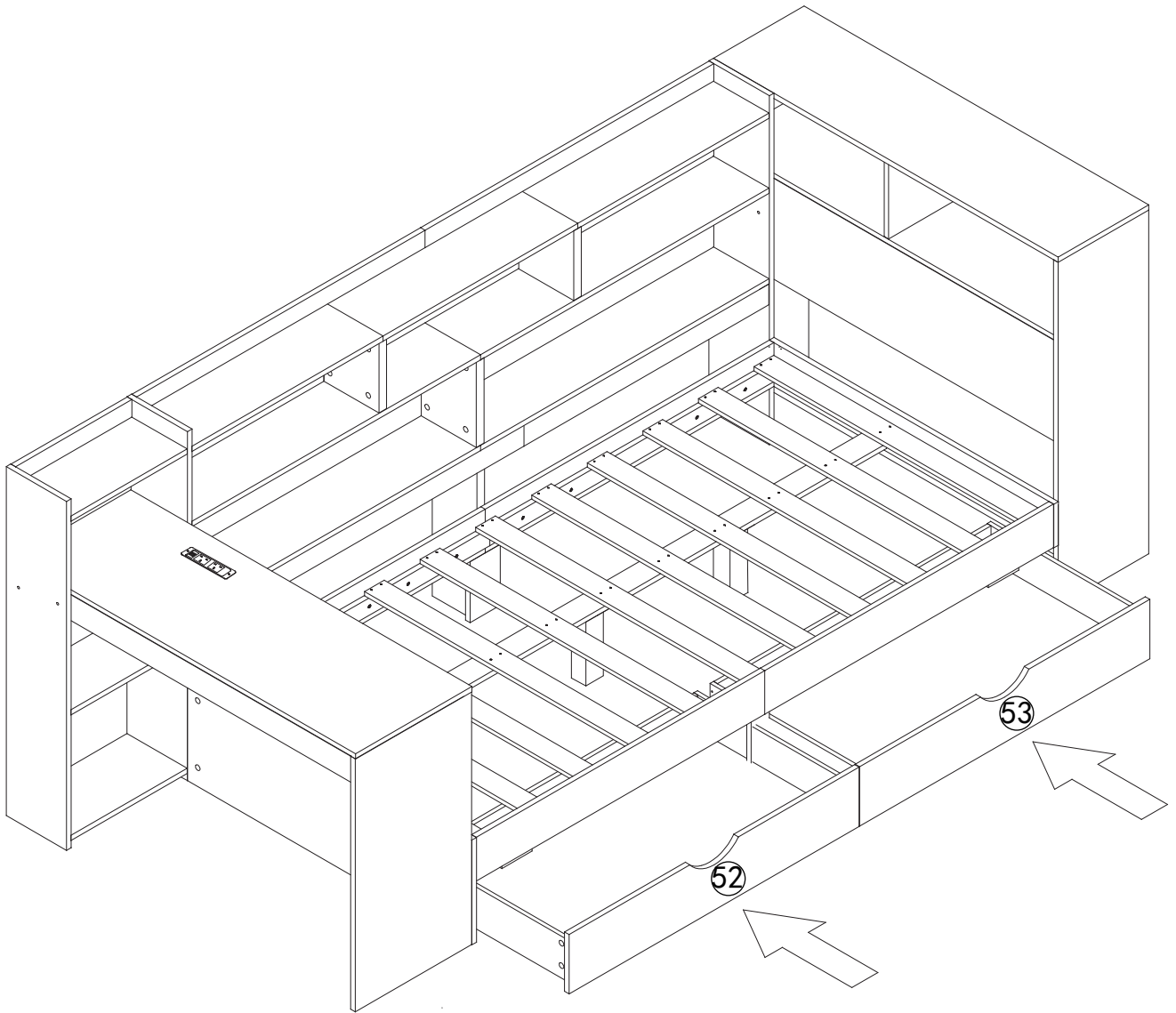

EN: In order to make the product more beautiful,  
please paste hardware U on the exposed holes.

DE: Um ein präzises produkt ästhetisieren zu  
können, fügen sie hardware U in eine entblöste  
öffnung ein

FR: Afin de rendre le produit plus beau, s' il vous  
plaît coller le matériel U sur les trous exposés.

IT: Per rendere il prodotto più bello, incollare l'  
hardware U sui fori esposti.

ES: Con el fin de hacer el producto más hermoso, por  
favor pega hardware U en los agujeros expuestos

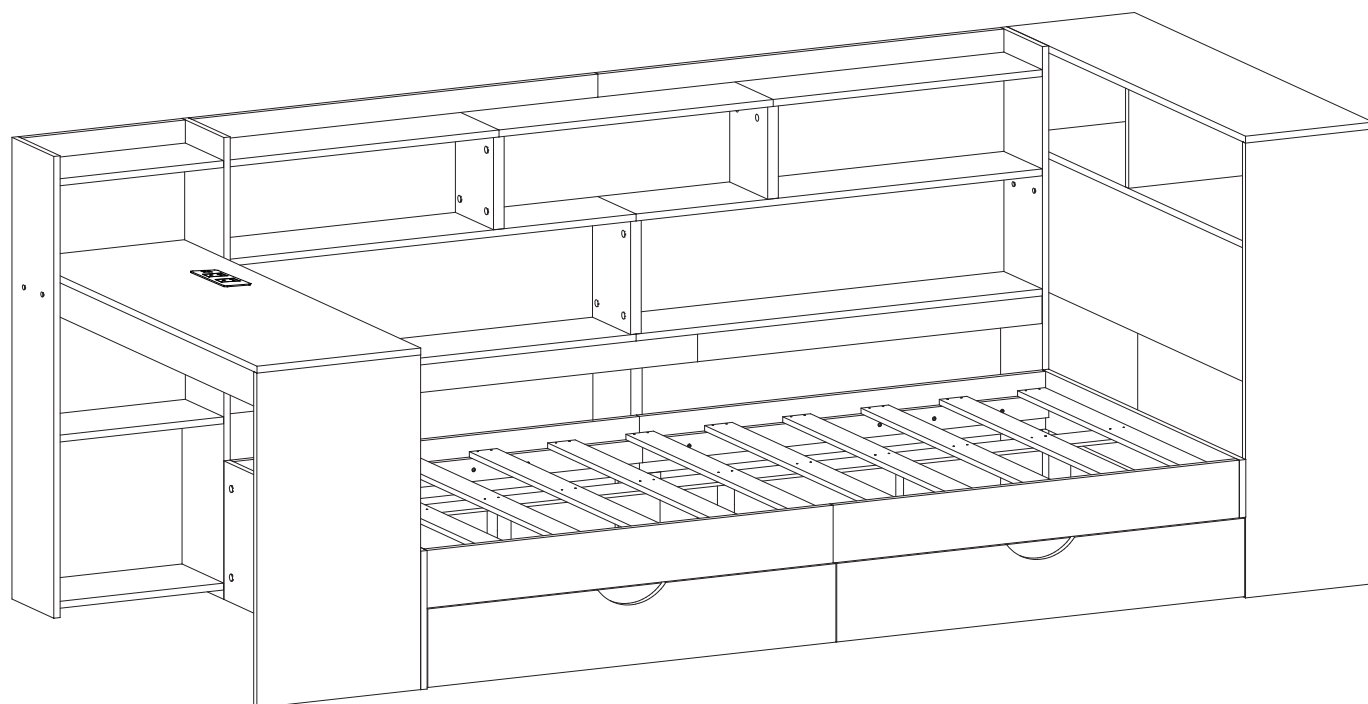
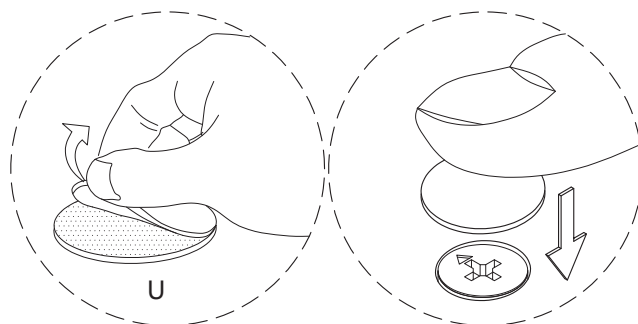

U x 200



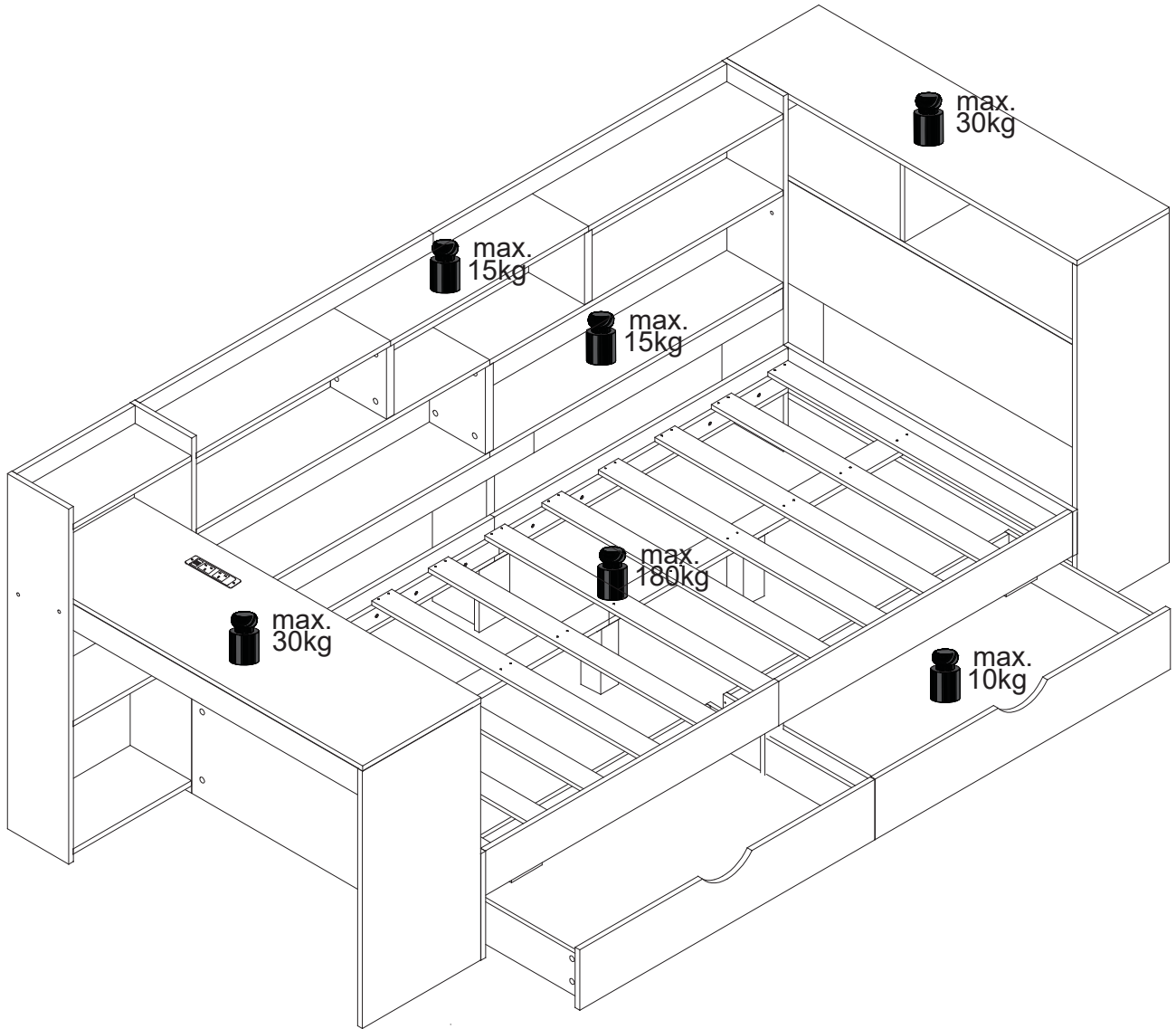

Reference No. : WTN23D07163421Z  
Applicant : Guangdong Zhongong Electrical Technology Co., LTD  
Address : 701, Building 29, Zhifu Garden, Xingtan Town,  
Shunde District, Foshan City  
Manufacturer : Guangdong Zhongong Electrical Technology Co., LTD  
Address : 701, Building 29, Zhifu Garden, Xingtan Town,  
Shunde District, Foshan City  
Product : Furniture socket  
Model No. : See model list  
Technical data : 250V AC, 50-60Hz 13A USB, output : 5.0V 2A 10W



### Test Standards:

**BS 1363-2: 2016+A1:2018**

**BS EN IEC 62368-1:2020/A11:2020**

The above product has been tested by us with the listed standards and found in compliance with the Electrical Equipment (Safety) Regulations 2016 of United Kingdom (S.I. 2016 No.1101). It is possible to use UKCA marking to demonstrate the compliance with the regulations.

**Audio/video, information and communication technology equipment- Part 1:Safety requirements**

**13 A plugs, socket outlets, adaptors and connection units- Part 2: Specification for 13 A switched and unswitched socket outlets**

The referred test report(s) show that the product complies with standard(s) recognized as giving presumption of compliance with the essential requirements in the above mentioned UK regulations. Other relevant UK regulations have to be observed.

After preparation of the necessary technical documentation as well as the declaration of conformity, the UKCA marking as shown below can be affixed on the equipment under the sole responsibility of the manufacturer.



Manager:Deval Qin  
Date: 2023-9-27

The statement is based on a single evaluation of the sample of above mentioned product.It does not imply an assessment of the whole production.

**Waltek Testing Group Co., Ltd.**

**Hotline:400-840-2288**

**E-mail:info@waltek.com.cn**

**Http://www.waltek.com.cn**

Ver.02. 29.07.2022, WALTEK is registered trademark. Utilisation and application requires prior approval.

# Attachment

## Model list



Reference No.:WTN23D07163421Z

Product name	Model name	Differences	differences
Furniture socket	ZG-JJY-1	13A 250V AC , USB output:5V 2A 10W	1-position socket without switch and USB
	ZG-JJY-1 UK		1-bit socket with switch and USB
	ZG-JJY-2		2-position socket without switch and USB
	ZG-JJY-2 UK		2-bit socket with switch and USB
	ZG-JJY-3		3-position socket without switch and USB
	ZG-JJY-3 UK		3-bit socket with switch and USB
	ZG-JJY-4		4-position socket without switch and USB
	ZG-JJY-4 UK		4-bit socket with switch and USB
	ZG-JJY-5		5-position socket without switch and USB
	ZG-JJY-5 UK		5-bit socket with switch and USB
	ZG-JJY-6		6-position socket without switch and USB
	ZG-JJY-6 UK		6-bit socket with switch and USB
	ZG-JJY-7		7-position socket without switch and USB
	ZG-JJY-7 UK		7-bit socket with switch and USB

**Waltek Testing Group Co., Ltd.**

Hotline:400-840-2288

E-mail:info@waltek.com.cn

Http://www.waltek.com.cn

Ver.02. 29.07.2022, WALTEK is registered trademark. Utilisation and application requires prior approval.

# Attachment

## Model list



Reference No.:WTN23D07163421Z

	ZG-JJY-8		8-position socket without switch and USB
	ZG-JJY-8 UK		8-bit socket with switch and USB

=====End of Attachment=====

**Waltek Testing Group Co., Ltd.**

Hotline:400-840-2288

E-mail:info@waltek.com.cn

Http://www.waltek.com.cn

Ver.02. 29.07.2022, WALTEK is registered trademark. Utilisation and application requires prior approval.