



**Assembly Instructions & User's Manual for 78" Pro Elite 4B  
European Ledge Island Grill Model Number: BS04-BI-LP**

**Pro Elite 4B Built-in Grill Model Number: BS04R-BI-LP**

**30" Double access drawers kit Item Number: K01000321A**

**60" Pro Elite 5B Northern Slate Q Grill Island Model Number:  
BS04RCIS-LP-D**

**78" Pro Elite 5B Texas Cream Island Grill Model Number: BS04RFIS-LP-B**

**Customer Assistance (spare/replacement parts): 1-877-419-2598  
or Email: [support@1800acs.com](mailto:support@1800acs.com)/[contact@zhprokan.com](mailto:contact@zhprokan.com)  
Canada: (888) 848-1663/ [contactca@zhprokan.com](mailto:contactca@zhprokan.com)**

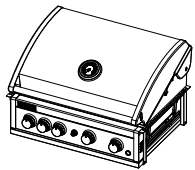

BS04R-BI-LP

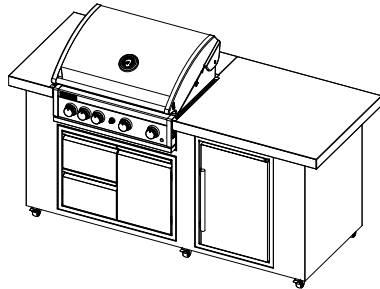

BS04-BI-LP

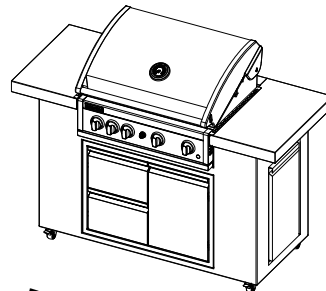

BS04RCIS-LP-D

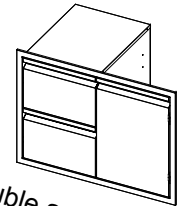

30" Double access drawers kit

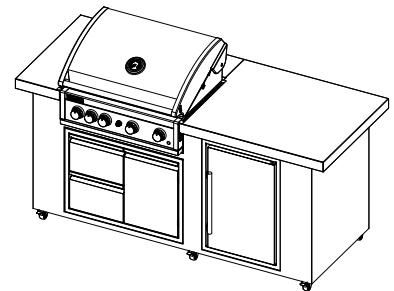

BS04RFIS-LP-B

THIS ASSEMBLY MANUAL CONTAINS IMPORTANT SAFETY INFORMATION. PLEASE READ AND KEEP FOR FUTURE REFERENCE.



## DANGER



If you smell gas:

1. Shut off gas to the appliance.
2. Extinguish any open flame.
3. Open lid.
4. If odor continues, keep away from the appliance and immediately call your gas supplier or your fire department.





## WARNING



1. Do not store or use gasoline or other flammable liquids or vapors in the vicinity of this or any other appliances.
2. An LP cylinder not connected for use shall not be stored in the vicinity of this or any other appliance.

# Table of Contents

Quality Statement.....	3
Important Safety Information .....	4
Natural Gas Safety Instructions.....	5
Full System Features.....	6
Package Contents .....	7
Product Information .....	8-9
Components .....	10
Tools.....	10
Assembly Instructions .....	11-18
Part Diagrams and Lists .....	19-31
 Warning.....	32
 Danger .....	33
Troubleshooting .....	34-36
Care & Use Instructions .....	37-44
Storage Instructions .....	45
Technical Data .....	46
Warranty Information .....	47

## Important Safety Information

- Please read all instructions carefully before assembling this product.
- Where applicable, and for your safety, assembly by an adult is strongly recommended.
- Use only vendor-supplied hardware to assemble this item. Using unauthorized hardware could jeopardize the structural integrity of the item.
- Hardware may loosen overtime. Periodically check that all connections are tight.

## Before Assembly

- Remove all parts and hardware from the box. Place all items on a carpeted or scratch-free work surface, as this will avoid damaging parts during assembly.
- The shipping box can provide an ideal work surface if none is available.
- Use the components and hardware lists below to identify, inventory and separate each of the hardware and components included.
- To avoid accidentally discarding small components or hardware, do not dispose of any packaging or contents of the shipping carton until assembly is complete.
- **DO NOT USE** power tools unless it is explicitly identified in this manual as required for use during assembly. Power tools can damage the fasteners, hardware and/or components.
- Do not fully tighten all fasteners / screws until all parts are in place. Failure to follow these instructions may cause the fasteners / screws to misalign during assembly.

## Care & Use

- Use a soft, clean cloth that will not scratch the surface when cleaning.

# Important Safety Information



## CAUTION



Failure to comply with these instructions may result in a hazardous situation which, if not avoided, may result in injury.

Spiders and small insects can spin webs and nest in the grill Burner Tubes during transit and warehousing which can lead to a gas flow obstruction resulting in a fire in and around the Burner Tubes. This type of "FLASHBACK FIRE" can cause serious grill damage and create an unsafe operating condition for the user.

**To reduce the chance of FLASHBACK FIRE you must clean the Burner Tubes as follows before initial use.** Also do this at least once a month in summer and fall or whenever spiders are active in your area, and if your grill has not been used for an extended period of time.

1. Remove the screws from the rear of each Main Burner using a Phillips Head Screwdriver or wrench.
2. Carefully lift each Burner up and away from the Gas Valve Orifice.
3. Check and clean Burner/Venturi Tubes for insects and insect nests. A clogged tube can lead to a fire beneath the grill.
4. Refer to the figure below and perform one of these 3 cleaning methods:

- METHOD 1: Bend a stiff wire or wire coat hanger into a small hook as shown and run the hook through the Burner Tube and inside the Burner several times to remove debris.

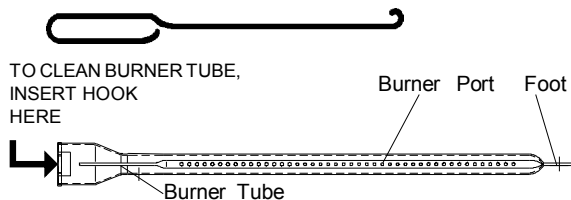

- METHOD 2: Use a bottle brush with a flexible handle and run the brush through the Burner Tube and inside the Burner several times to remove any debris.
- METHOD 3: Use an air hose to force air through each Burner Tube. The forced air should pass debris or obstructions through the Burner and out the Ports.

For safe operation ensure the Gas Valve Assembly Orifice is inside the Burner Tube before using your grill. See figure. If the Orifice is not inside the Burner Tube, lighting the Burner may cause explosion and/or fire resulting in serious bodily injury and/or property damage.

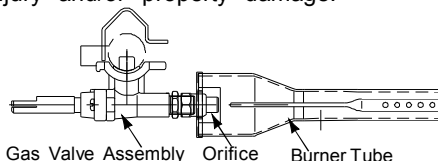

## PRE-ASSEMBLY

Read and perform the following pre-assembly instructions:

### Tools Required for Assembly:

- protective work gloves
- protective eyewear
- Phillips Head Screwdriver

- You will need assistance from another person to handle the grill head and other large and heavy parts.
- Open lid of shipping carton. Remove top sheet of cardboard and packing materials. Lay cardboard sheet on floor and use as a work surface to protect floor and grill parts from scratches.
- You may slice the carton front corners with a utility knife to lay open the carton front panel. This allows you to raise the Lid and remove the components packed inside, making it easier to lift.
- Use the Hardware and Part Diagrams to ensure all items are included and free of damage.
- Do not throw away the bags of hardware that are included with boxed parts. These are required for assembly.
- Do not assemble or operate the grill if it appears damaged. If there are damaged or missing parts when you unpack the shipping box or you have questions during the assembly process call 1-877-419-2598; [email:support@1800acs.com/](mailto:support@1800acs.com) [contact@zhprokan.com](mailto:contact@zhprokan.com) Monday through Friday from 8:00 a.m. to 8:00 p.m. EST

### Grill Installation Codes

The installation must conform with local codes or, in the absence of local codes, with either the National Fuel Gas Code, **CSA/ANSI Z21.58-2022 • CSA 1.6-2022**.

**WARNING:** Grease can get very hot. Always handle the Grease Tray with a flame retardant BBQ mitt. Before removing the Tray, always be sure that the grill has properly cooled. Be aware that the tray does contain grease and be extremely careful when removing the tray to prevent spillage. Failure to follow these instructions could cause serious bodily injury or property damage.



## CAUTION



To reduce the chance of **FLASHBACK FIRE** you must clean the Burner Tubes at least once a month in summer and fall or whenever spiders are active in your area, and if your grill has not been used for an extended period of time.



## CAUTION



**Never** cover or wrap the Cooking Grids, bottom of the Grill Bowl, or Grease Tray with aluminum foil or any other material that will absorb grease.

# Natural Gas Safety Instructions

- Your Natural Gas BBQ is designed to operate on Natural Gas only, at a pressure of 7" water column (W.C.) (1/4 psig or 1.75 kpa), regulated at the residential meter. Check with your gas utility company for local gas pressure and with your local municipality for building code requirements. If your residential gas line pressure has not been regulated to 7" W.C., contact your local gas utility company for professional assistance.
- The gas pressure Regulator supplied with this appliance must be used. This Regulator is set for an outlet pressure of 4" W.C.

- It is recommended that a Shut Off Valve be installed at the gas supply source outdoors. Install at a point after the gas pipe exits the outside wall and before the Quick Disconnect Hose, or install it at the point before the gas line piping enters the ground. See Figure 1.

Figure 1.

- Pipe sealing compound or pipe thread tape resistant to the action of Natural Gas must be used on all male pipe threads when making the connection.
- Disconnect your gas BBQ from fuel source when the gas supply is being tested at high pressures. This gas BBQ and its individual Shut Off Valve must be disconnected from the gas supply pipe system during any pressure testing of that system at pressure in excess of 1/2 psi (3.5kpa).
- Turn off your gas BBQ when the gas supply is tested at low pressures. The BBQ must be isolated from the gas supply pipe system by closing its individual Manual Shut Off Valve during any pressure testing of the gas supply pipe system at pressures equal to or less than 1/2 psi (3.5kpa).
- The Quick Disconnect connects to a 3/8 inch NPT thread from gas source. The Quick Disconnect fitting is a hand operated device that automatically shuts off the the flow of gas from the source when it is disconnected.
- The Quick Disconnect fitting can be installed horizontally, or pointing downward. DO NOT install the fitting with the opening pointing upward because the fitting could collect water and debris.
- The Dust Covers (plastic plugs) provided with the Quick Disconnect help keep the open ends clean while disconnected.
- The outdoor connector must be firmly attached to a ridged permanent construction.
- The Quick Disconnect MUST BE installed above ground.

- **WARNING:** Do not route the 10 foot Quick Disconnect Hose under a deck. The hose must be visible and inspected prior to each grill use.

Figure 1  
(For Natural Gas Model Only)

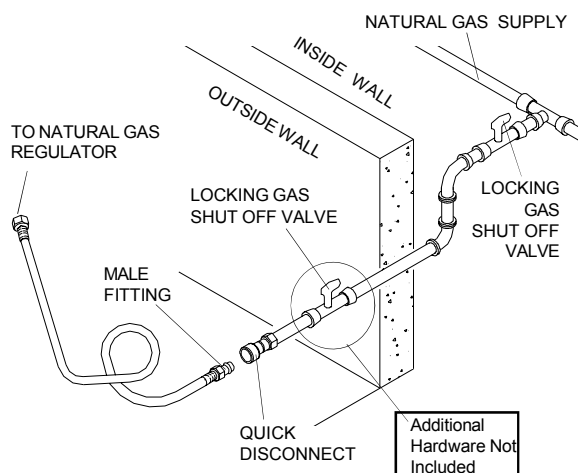

## Gas Line Piping

If the length of line required does not exceed 50 feet, use a 5/8" O.D. tube. One size larger should be used for lengths greater than 50 feet.

Gas piping may be copper tubing, type K or L; polyethylene plastic tube, with a minimum wall thickness of .062 inch; or standard weight (schedule 40) steel or wrought iron pipe.

Copper tubing must be tin-lined if the gas contains more than 0.3 grams of hydrogen sulfide per 100 cubic feet of gas.

Plastic tubing is suitable only for outdoor, underground use.

Gas piping in contact with earth, or any other material which may corrode the piping, must be protected against corrosion in an approved manner.

Underground piping must have a minimum of 18" cover.



## Test Connections

All connections and joints must be thoroughly tested for leaks in accordance with local codes and all listed procedures in the latest edition of **CSA/ANSI Z21.58-2022 • CSA 1.6-2022**.

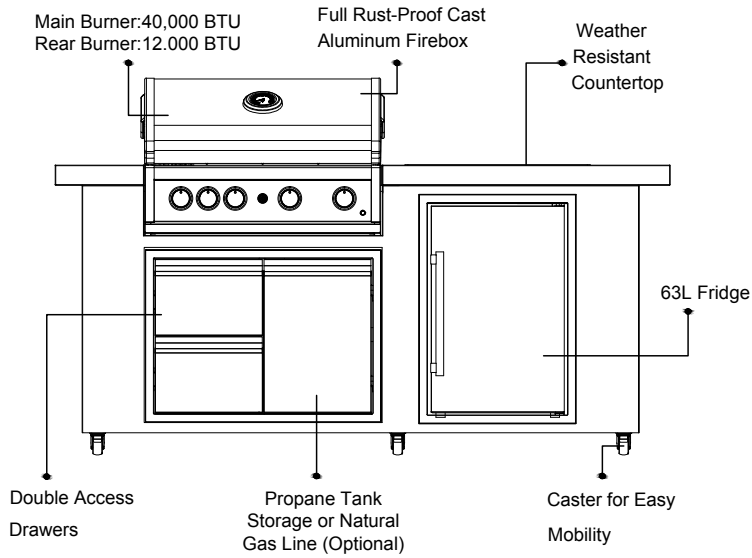
## Full System Features-BS04-BI-LP



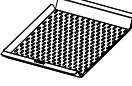
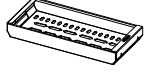

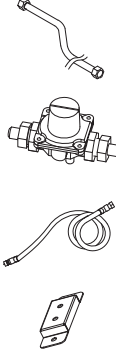
### Sold Separately

Component	Description	Part#
	Grill Topper	KPSS005
	Charcoal Insert	KPSS004
	Self-Leveling Adjustable Legs	S0221-13
	Natural Gas Conversion Kit	KPSS002

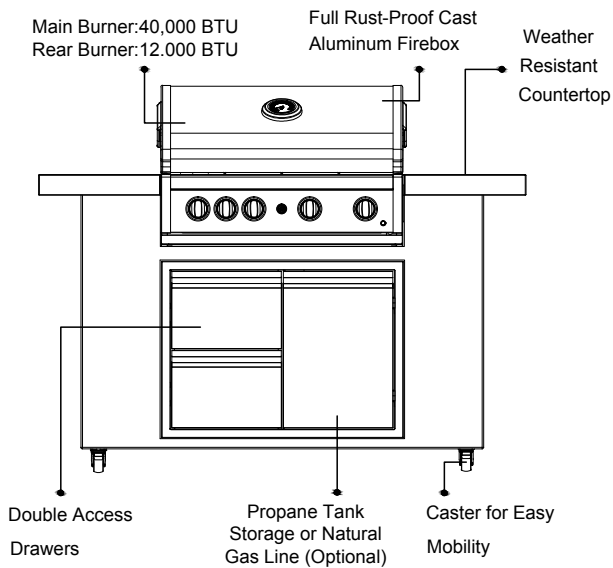
## Full System Features-BS04RCIS-LP-D

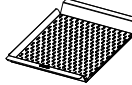
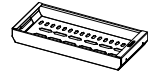

### Sold Separately

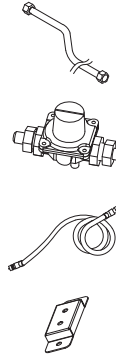
Component	Description	Part#
	Grill Topper	KPSS005
	Charcoal Insert	KPSS004
	Self-Leveling Adjustable Legs	S0221-13
	Natural Gas Conversion Kit	KPSS002

# Package Contents

## Y0250200BP Rotisserie Assembly Parts Diagram

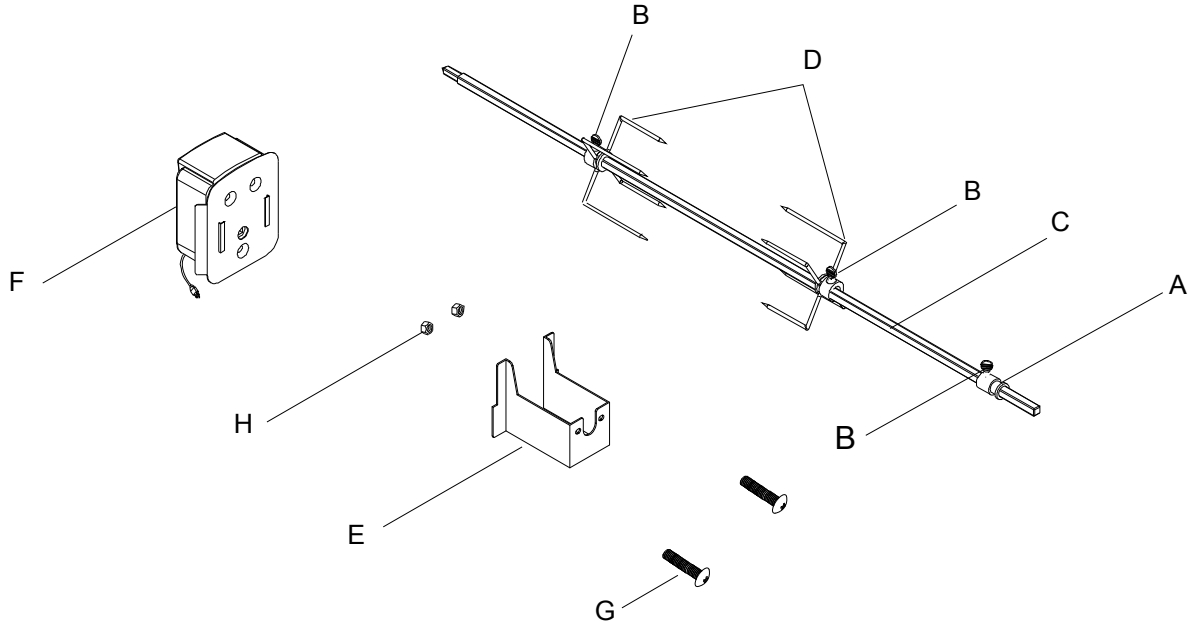

**IMPORTANT: Please note that the rotisserie rod is packed on the back of the grill box.**



### Y0250200BP Rotisserie Assembly Parts List

Component	Description	PAR T#	Quantity
A	Rot. Collar	P05508200A	1
B	Rot. Thumbscrew 1/4"x1/2"	S196G04081	3
C	Rot. Spit	S0207-137	1
D	Rot. Holding Fork	P05508023A	2
E	Rot. Motor Bracket	P05508226A	1
F	Rot. Motor/AC	P07101050B	1
G	Rot. Screw#10-24x1"UNC	S112G10121	2
H	Rot. Nut #10-24	S362G10121	2

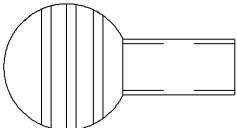
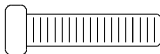
### Hardware for Rotisserie

Rot. Thumbscrew 1/4"x1/2", (B) Part No. S196G04081 Qty: 3 	Rot. Screw#10-24x1"UNC(G) Part No. S112G10121 Qty: 2 	Rot. Nut #10-24(H) Part No. S362G10121 Qty: 2 
--	---	--

# Product Information

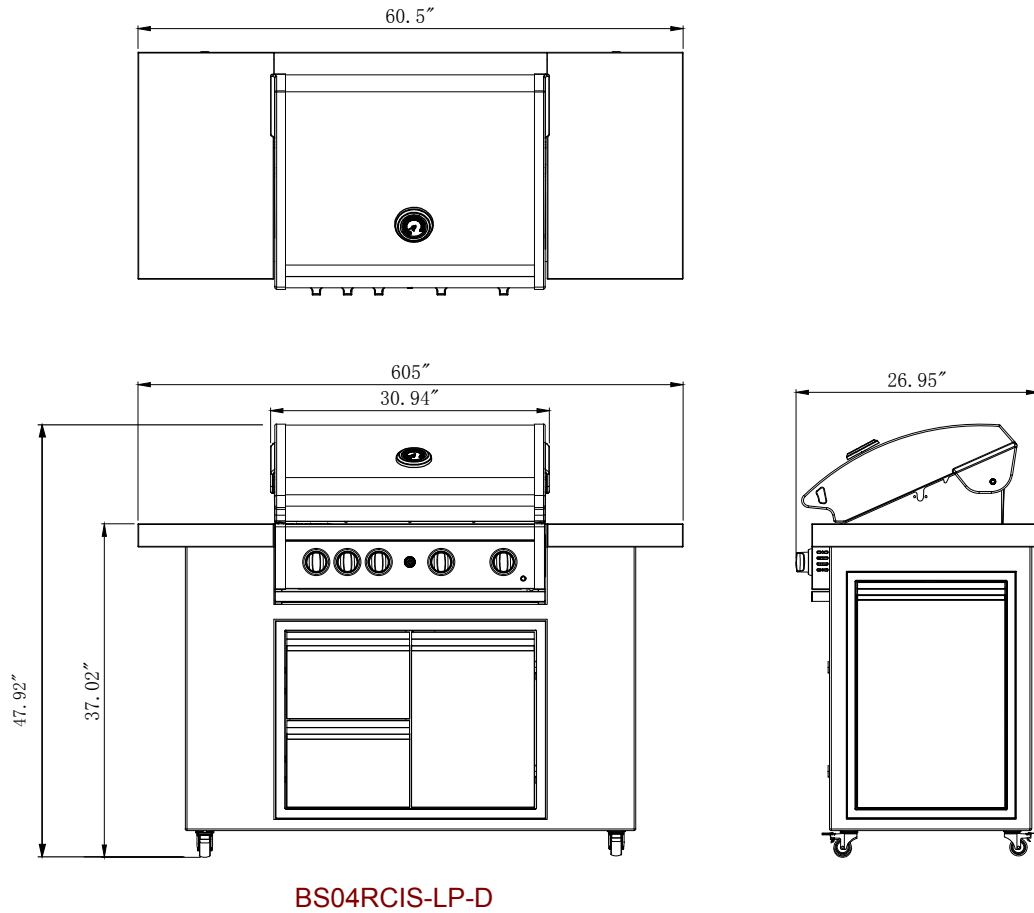
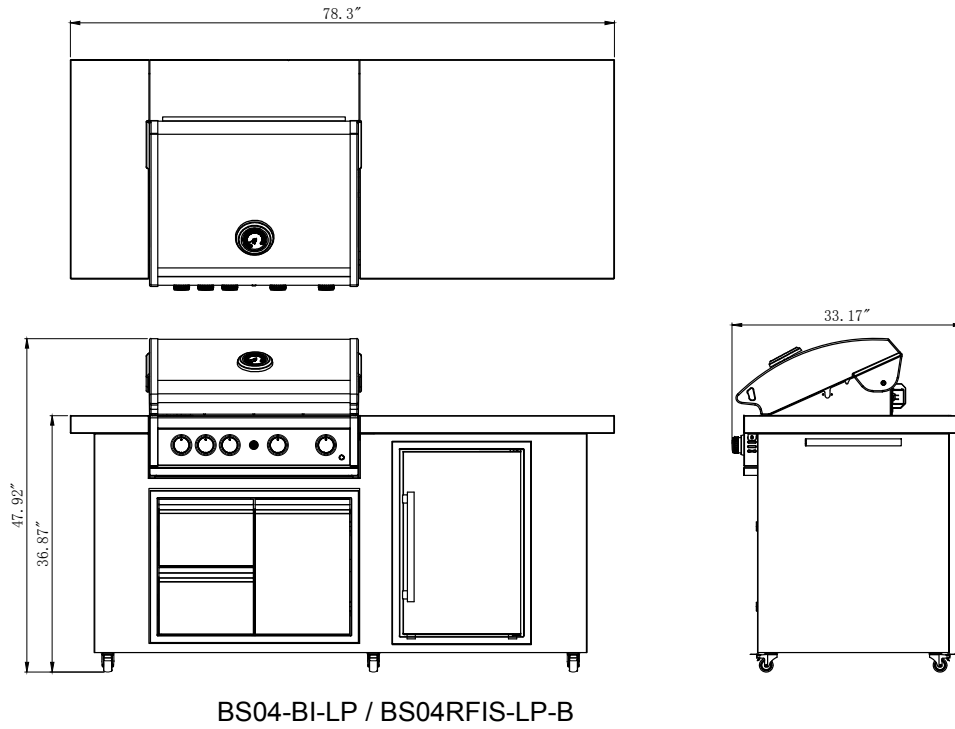

# Product Information

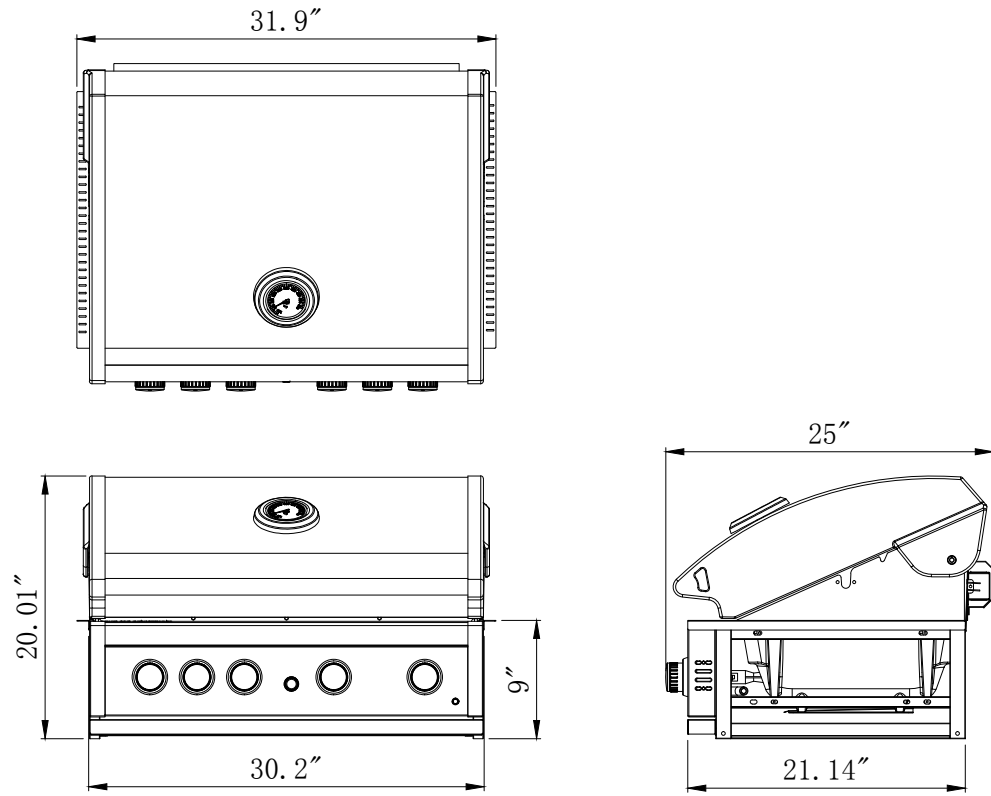

# Components

## Components

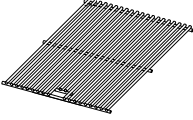
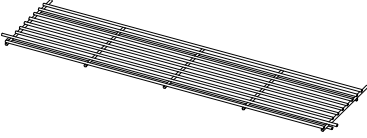
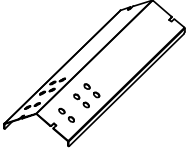
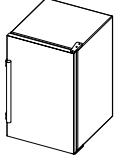
<p>Cooking Grid No.S0224-08 Qty 2</p>	<p>Warming Rack No.S0224-09 Qty 1</p>	<p>Flame Tamer No.S0224-06 Qty 4</p>
		
<p>Fridge No.S0226-13 Qty 1</p>		
		

## Tools

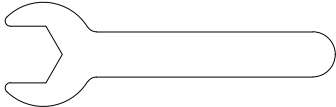
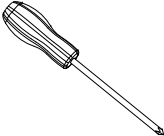
<p>Caster Wrench</p>	<p>Phillips Screwdriver (Not Included)</p>	
		

# ASSEMBLY BS04-BI-LP

**CAUTION :** To assemble this grill, you should obtain assistance from another person when handling some of the larger, heavier pieces.

**Step 1: Connect regulator to propane tank.**

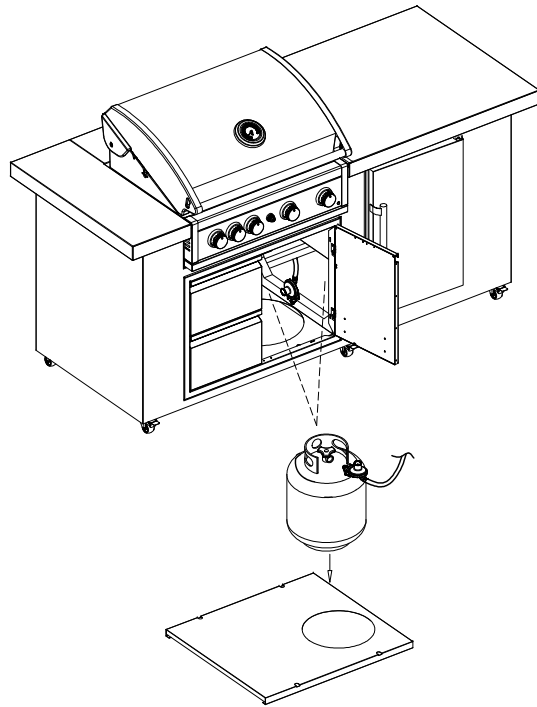

## How to Install fridge handle?

**Open the gasket from the rear of the door**

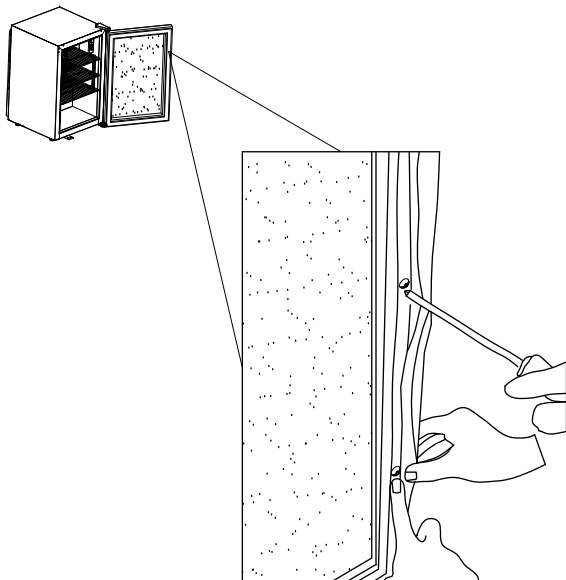

**Install the handle**

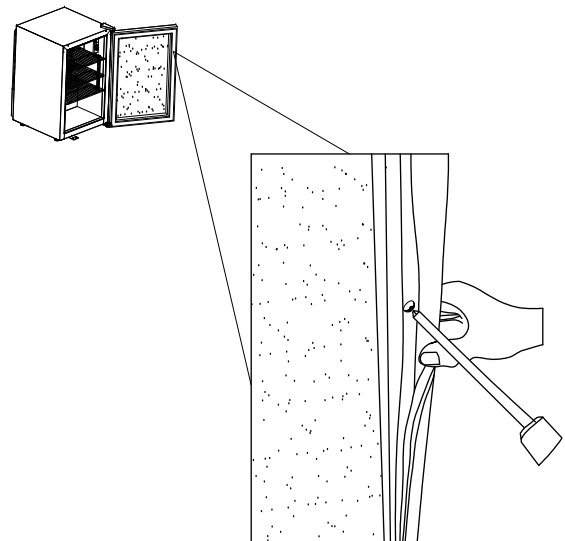

## Step 2: Adjust Island Assembly Set for Leveling (on uneven ground).

- Adjustable Level are located underside of the Island Assembly as shown.
- If the Island sets are not level with each others, adjust the 6 preassembled Adjustable Level using the wrench provided.
  - Turn the adjusters clockwise to raise the height of the Island.
  - Turn the adjusters counterclockwise to lower the Island.
- After leveling, double check for making sure that all the adjusters touch the ground.
- IMPORTANT:** For illustration purpose the Island Assembly Set is shown on a tilted angle. **FOR YOUR SAFETY, DO NOT TILT** your Island Assembly at any time.



Caster Wrench

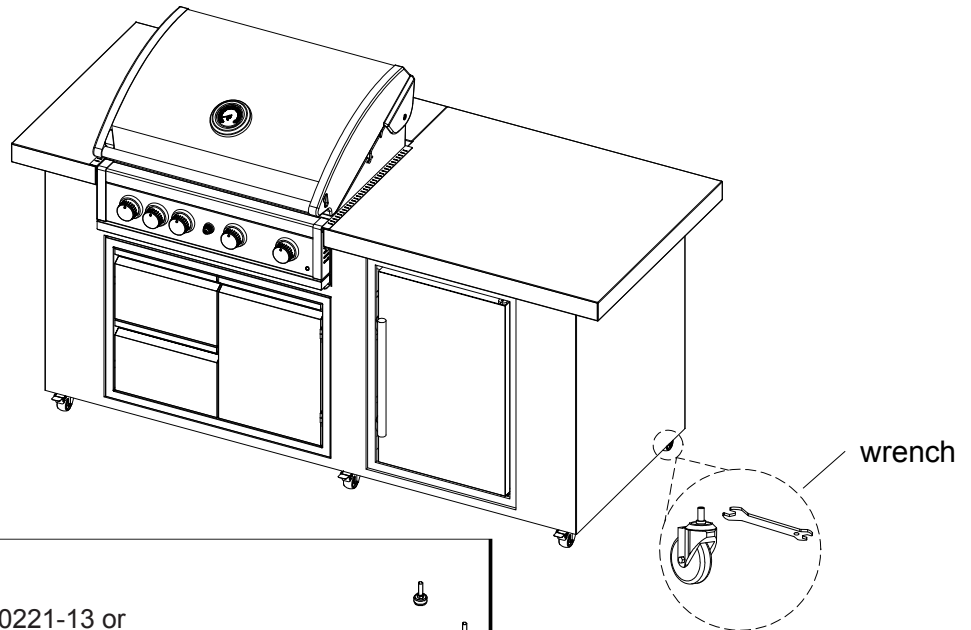

Self-Leveling adjustable legs: Sold separately. (Manufacturer part #: S0221-13 or KPSS019 (1SET=4PCS).

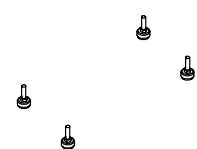

## Step 3: Install Ignitor Battery

- Remove Ignitor Cap from Control Panel.
- Place supplied AA battery into the Ignitor Slot with positive pole facing you.
- Position the Cap and Spring over the AA battery and tighten onto Control Panel.

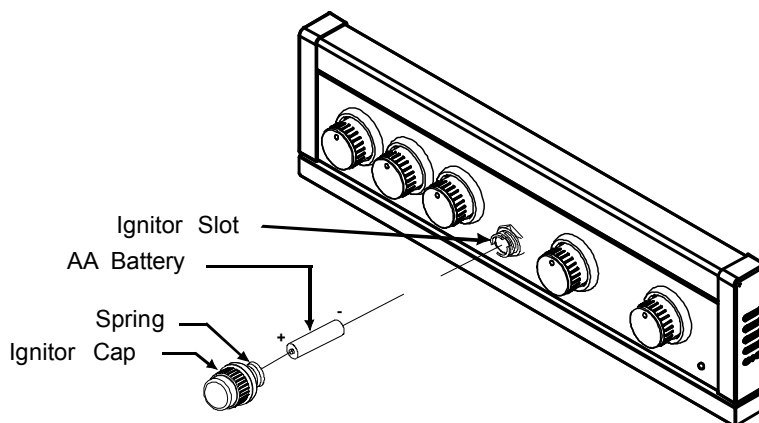

### NOTE: CORRECT BATTERY USE

- Always purchase the correct size and grade of battery most suitable for the intended use.
- Replace all batteries of a set at the same time.
- Clean the battery contacts and also those of the device prior to battery installation.
- Remove batteries from equipment which is not to be used for an extended period of time.
- Remove used batteries promptly.

#### Step 4: Install Cooking Components

- Place the Flame Tamers above the Burners.
- Place the Cooking Grids on the ledge above the Flame Tamer.
- Place the Secondary Cooking Rack onto the Warming rack holder.

### Final Grill Assembly Step

When you have finished assembling your grill be sure that all things are correctly positioned for safe operation of your grill.

Before each use of the grill, make sure the Grease Tray is fully placed under the Grill Bowl.

**CAUTION:** Before each use of your grill, inspect the Grease Tray, Flame Tamer and inside of the Grill Bowl to be sure there is no excessive grease and debris buildup. Clean the Grease Tray, Flame Tamer and inside of the Grill Bowl frequently to eliminate grease/debris build-up and to prevent grease fires.

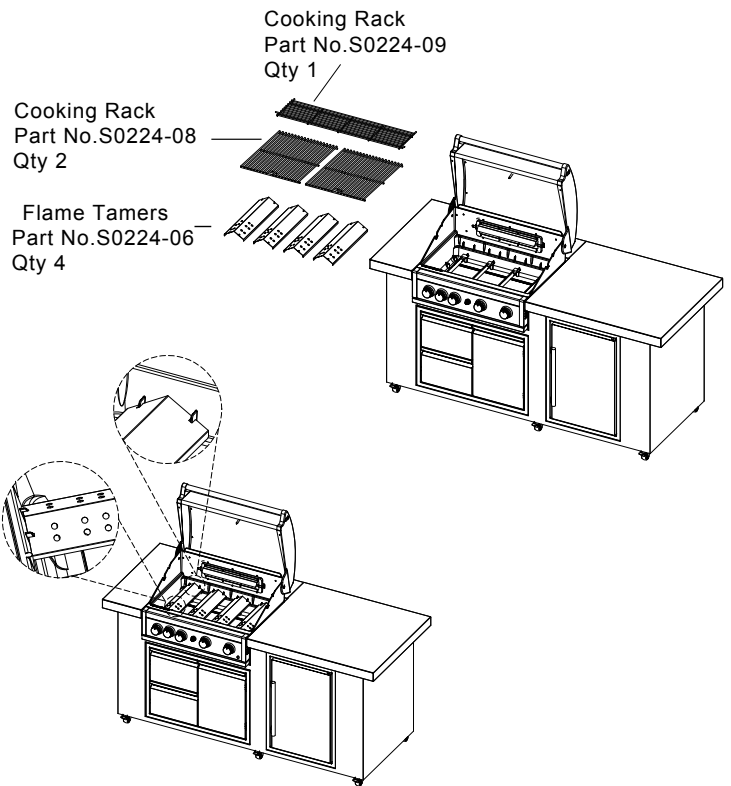

#### Step 5:

1. Remove all components from the carton.
2. Attach the Motor Bracket on the outside of the left grill bowl panel. Align the two holes of the Bracket with the holes on the grill bowl panel. Tighten securely using two Screws #10-24x1" UNC and Nuts provided.(Fig. 1) Attach the Collar Support Bracket with a threaded screw over the middle hole on the right grill bowl panel. Tighten securely using a wing nut provided.

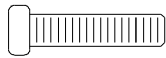

Rot. Screw #10-24x1" UNC x2



Rot. Nut #10-24 x2

⊙ Washer 3/16"  
Qty.2

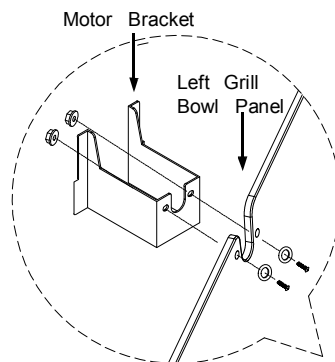
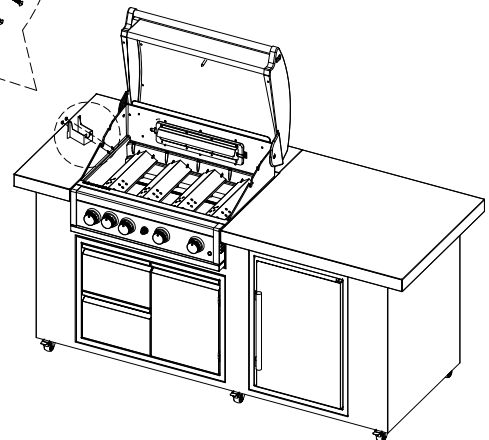
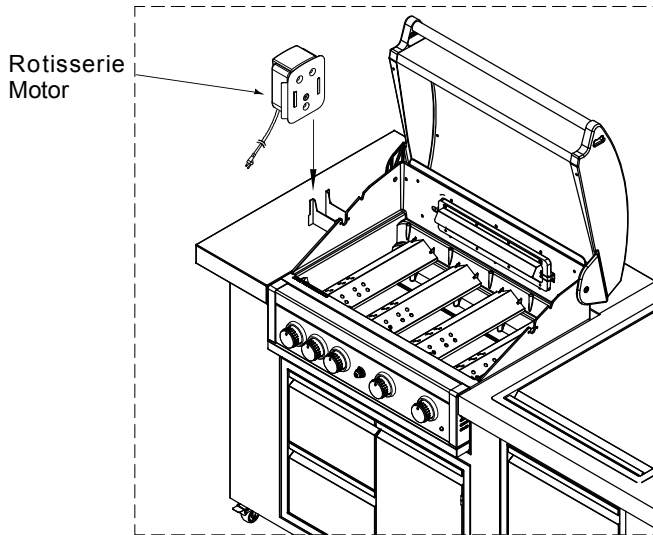

Fig. 1



**Step 6:** Install the AC (alternating current) Rotisserie Motor onto the Motor Bracket as shown below. Be sure the Motor attaches to the Bracket with the electrical cord down.



**Step 7:** Insert the assembled Rotisserie into the Motor as shown below. The Motor should be on the left side of your grill. Place the Collar into the slot opening on collar support bracket, then tighten the Collar Thumbscrew on the left end of Collar. The Collar will stabilize the Rotisserie during the cooking process and allows the Rotisserie Spit to turn smoothly. Plug the Rotisserie Cord into the GFCI outlet and plug the GFCI Power Cord to a properly grounded outlet, then turn on to test.

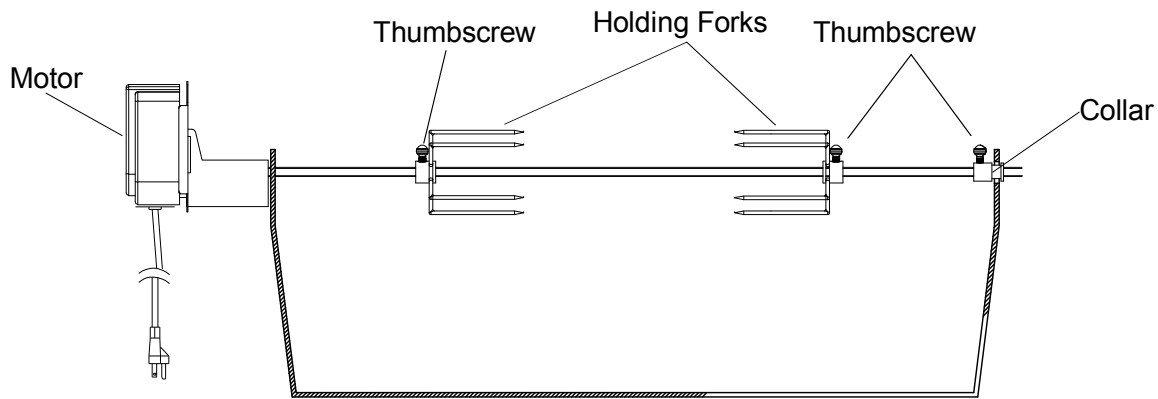

**The Collar must always be used with this Rotisserie**

BEFORE rotisserie cooking you will need to remove the Cooking Rack/Secondary from your grill. When rotisserie cooking place a Cooking Pan under the food to be cooked. This will capture the drippings and keep your grill clean of excess grease which could cause a fire. Use caution when moving a Cooking Pan containing hot oils.

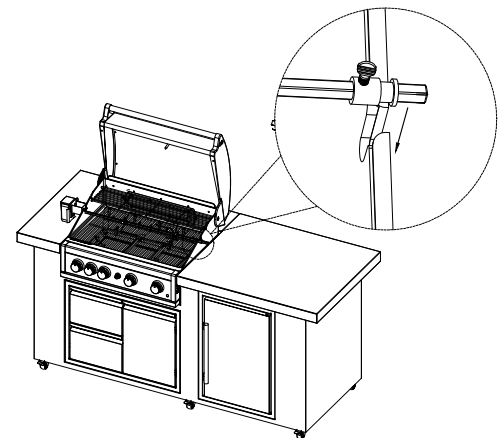

**Step 8:** Connect the power supply, and use the switch on the control panel to turn on the lights.

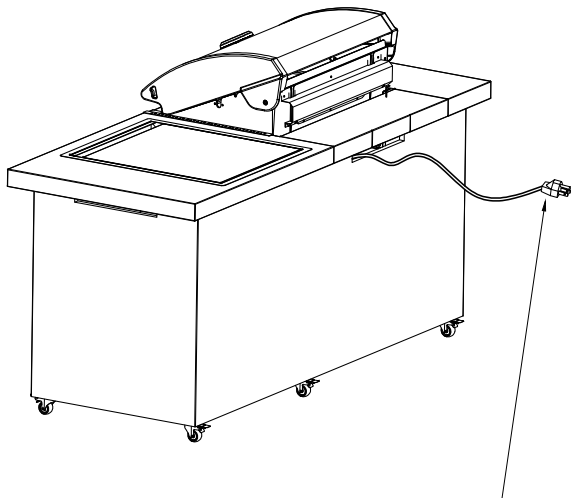

Plug the cord to power the grill lights

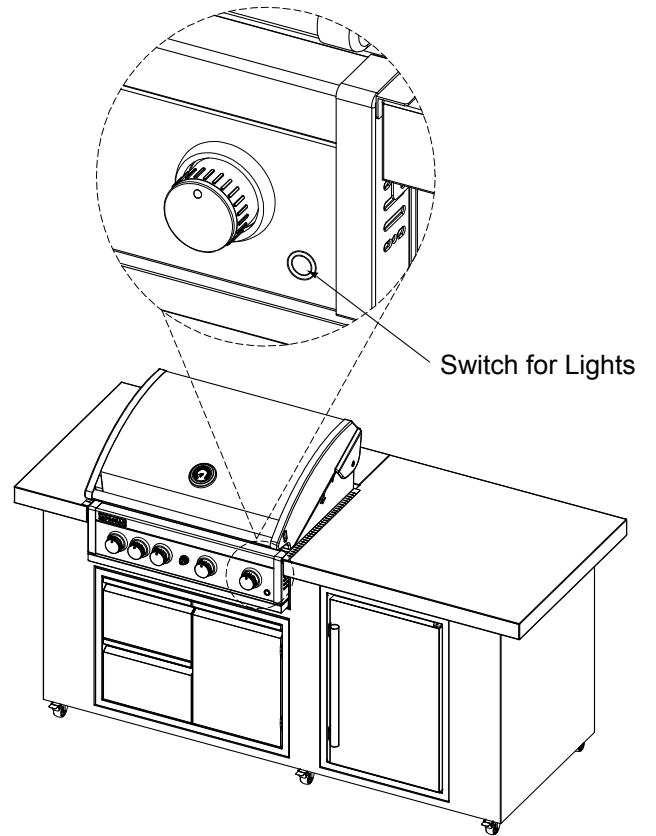

**Power operations for Grill Lights**

# ASSEMBLY BS04R-BI-LP

## Step 1: Install the Trim brackets .



Flat Head Screw 3/16"x1/2"  
Qty.4

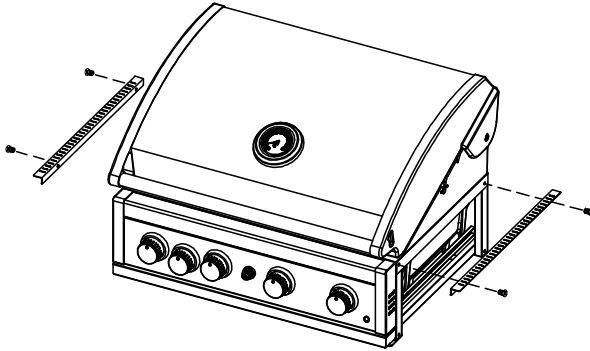

## Step 2: Install the grill onto the housing.

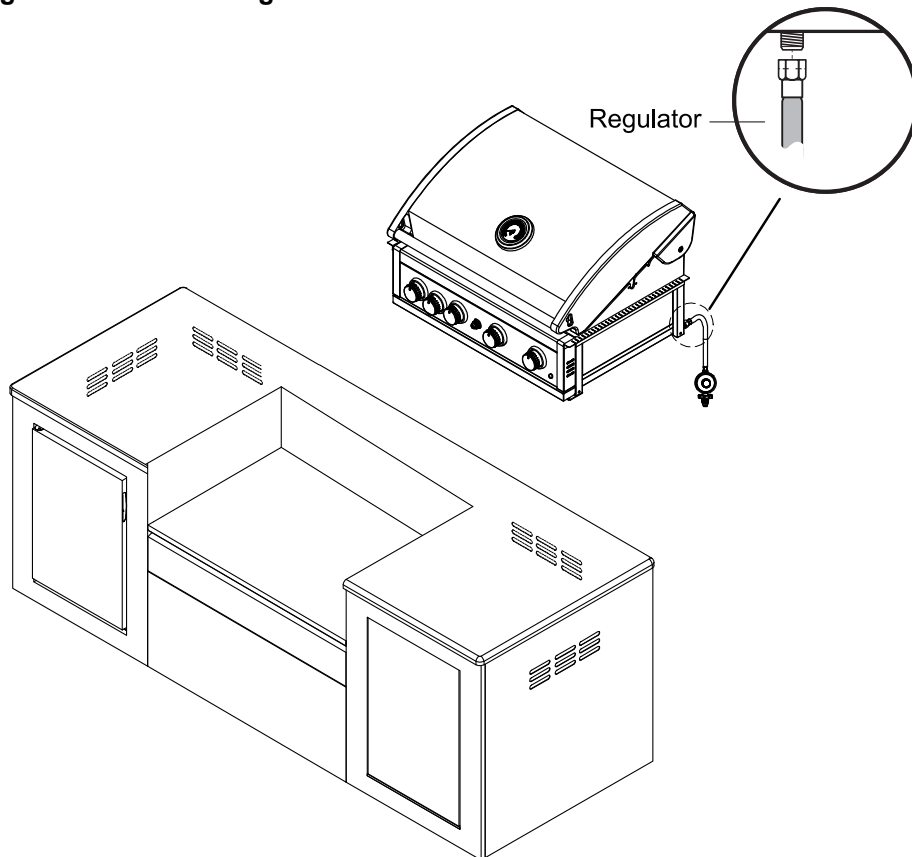

**MOUNTING CUT - OUT**

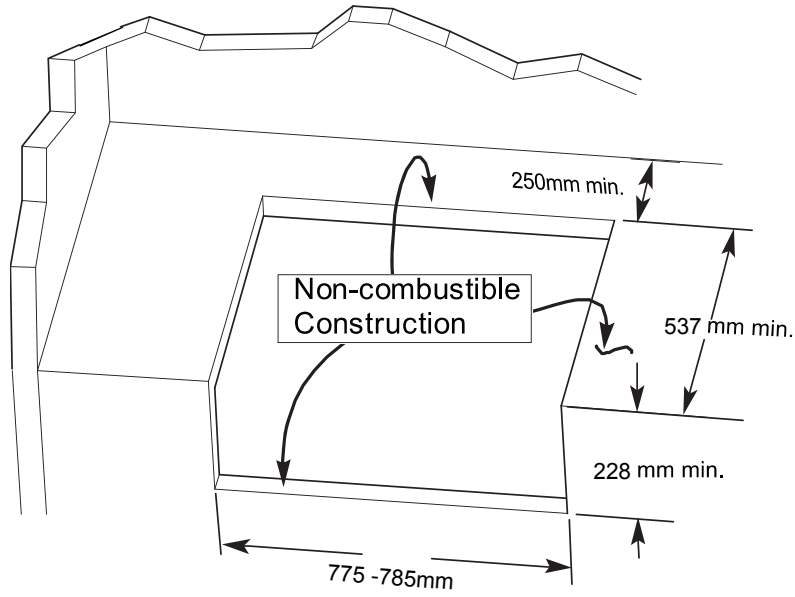

**Step 3: Ignition Battery.**

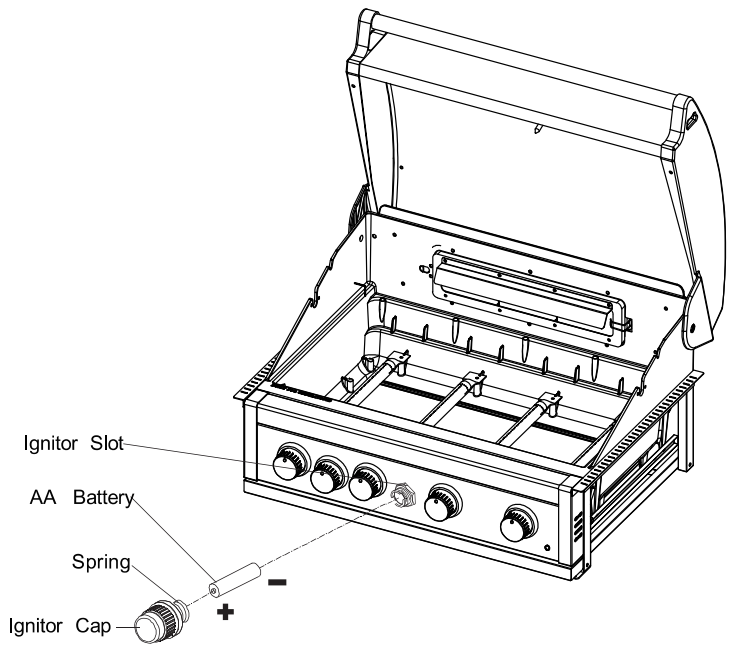

**Step 4: Cooking Component Installation.**

Warming Rack Part  
No. S0224-09 Qty 1

Cooking Grid  
Part No. S0224-08  
Qty 2

Flame Tamer  
Part No. S0224-06  
Qty 4

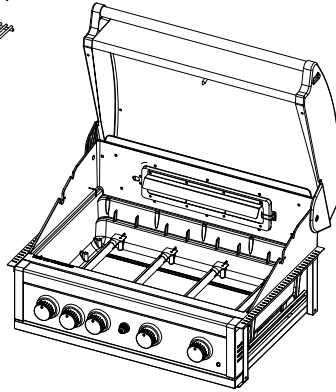

WarmingRack  
Part No. S0224-09  
Qty 1

Cooking Grid  
Part No. S0225-01B  
Qty 3

Flame Tamer  
Part No. S0224-06  
Qty 3

Hot plate  
Part No. S0225-02B  
Qty 1

No flame Tamer Needed for  
Griddle Setup

**Step 5: Install Transformer light the Lights.**

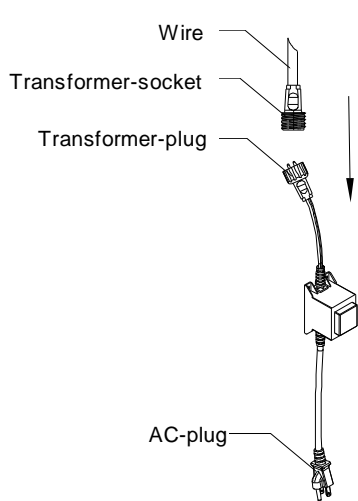
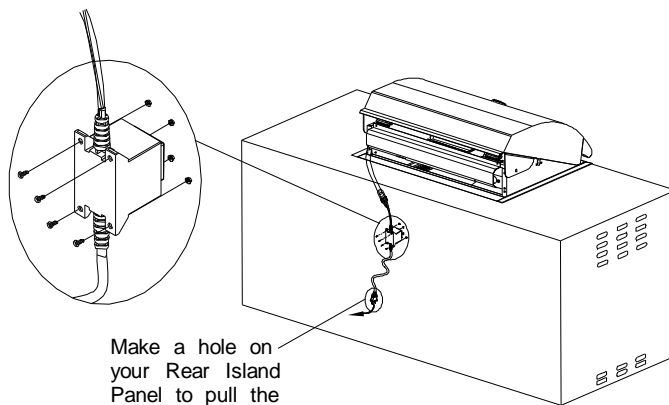

Fig. 1



Make a hole on  
your Rear Island  
Panel to pull the  
cord out

Fig. 2

An island is shown for illustrative  
purposes in the diagram.

# Part Diagrams and Lists-BS04R-BI-LP

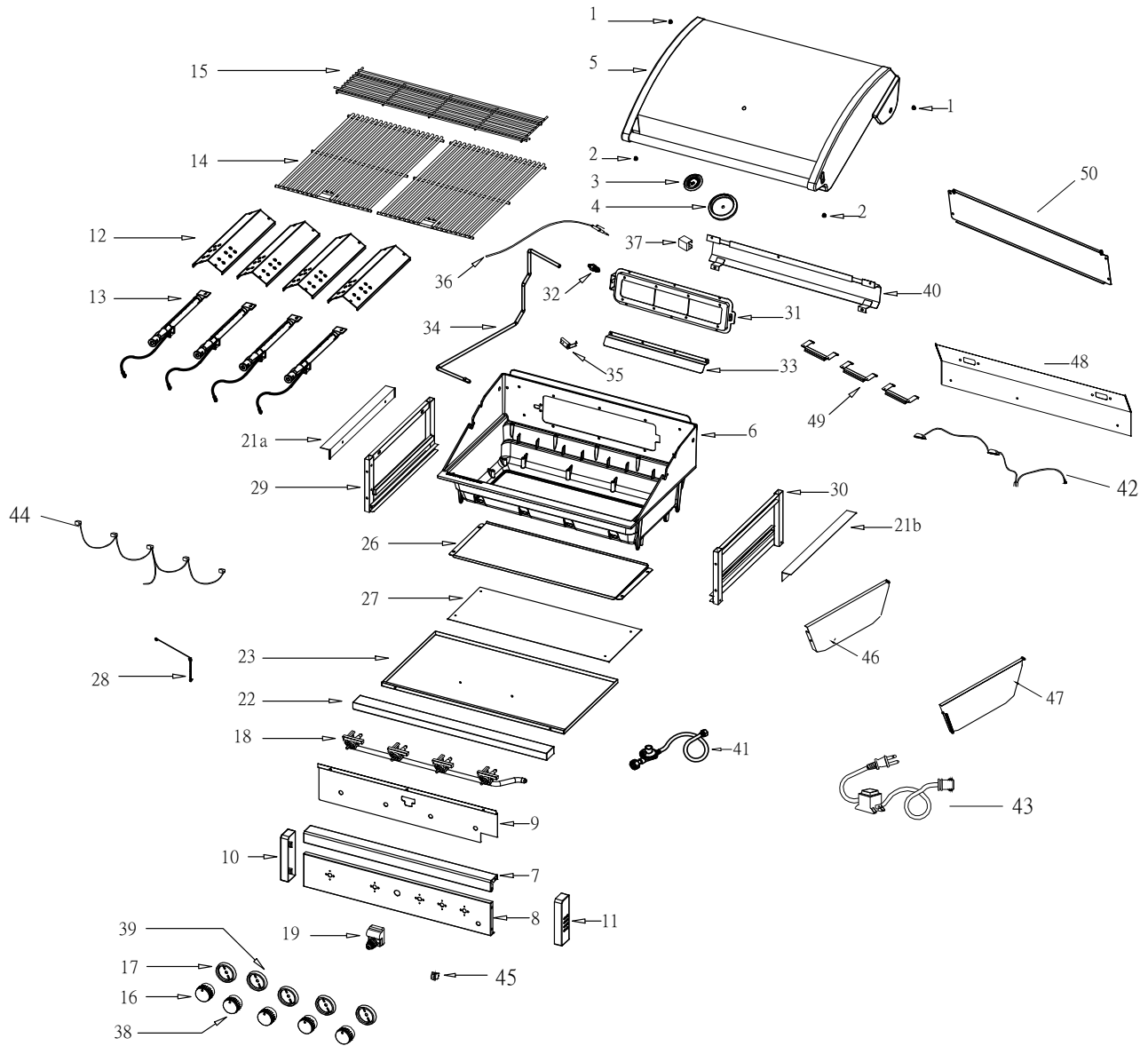

## Part Diagrams and Lists-BS04R-BI-LP

KEY	DESCRIPTION	PART#	QTY
1	Protective Pad,Rear	S0111-160	2
2	Protective Pad,Front	S0111-160	2
3	Temperature Gauge	S0209-16	1
4	Thermometer Bezel	S0202-19	1
5	Lid Assembly	S0226-01Z	1
6	Cast Aluminum Grill Box	S0224-01	1
7	Control Panel,Upper	S0226-02	1
8	Control Panel,Lower	S0230-12	1
9	Gas Valve Heat Shield Panel	S0224-04	1
10	Control panel end cap, Left	S0224-05A	1
11	Control panel end cap, Right	S0224-05B	1
12	Flame Tamers	S0224-06	4
13	Main Burner	S0224-07	4
14	Cooking Grid	S0224-08	2
15	Warming Rack	S0224-09	1
16	Conctrol Knob	S0224-61	4
17	Control knob Bezel	S0202-22	4
18	Gas Valve/ Manifold Assembly	S0224-79	1
19	Electric Ignitor,6-port	M0126-65	1
21A	Built-in Bracket, Left	S0224-73	1
21B	Built-in Bracket, Right	S0224-74	1
22	Grease Tray Handle, Main Firebowl	S0224-10	1
23	Main Firebox Grease Tray	S0224-11	1
26	Grease tray Heat Shield Panel -Upper	S0224-13	1
27	Grease tray Heat Shield Panel -Lower	S0224-14	1
28	Lighting Stick	S0202-45	1
29	Bowl Panel,Left	S0224-15Z1	1
30	Bowl Panel,Right	S0224-15Z2	1
31	Rear Burner Assembly	S0224-18Z1	1
32	Rear Burner Valve Orifice	S0211-39	1
33	Rear Burner Wind Shield Bracket	M0126-56	1
34	Rotisserie Burner Extension Tube	S0224-98	1
35	Rotisserie Burner Electrode	S0003-54	1
36	Rear Burner Thermocouple	S0224-99	1
37	Rotisserie Burner Thermocouple Bracket	S0056-56	1
38	Control knob for Rotisserie Burner	S0158-30	1
39	Control knob Bezel	S0202-22	1
40	Rotisserie Burner Wind Shield Panel	S0224-65	1
41	Regulator With Hose Assembly	S0207-100	1
42	Light	S0230-19	1 set
43	Transformer	S0234-04	1
44	Electric Wire Set	S0234-05	1
45	Switch for Light	S0234-06	1
46	Inner Fire Bowl Panel, Left	S0230-10A	1
47	Inner Fire Bowl Panel, Right	S0230-10B	1
48	Bracket for Lights	S0230-15	1
49	Crossfire box	S0225-07Z	3
50	Wind Shield Panel	S0230-14	1

## Appendix Page

for Pro Elite 4B Built-in Grill (Item Number: K04000345A; Model Number: BS04R-BI-LP)

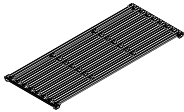
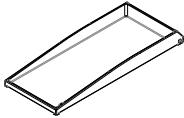
DESCRIPTION	PART#	QTY	COMPONENTS
Cast Iron Cooking Grid for Pro Elite	S0225-01	3	
Cast Iron Hotplate for Pro Elite	S0225-02	1	

# Part Diagrams and Lists-BS04RCIS-LP-D

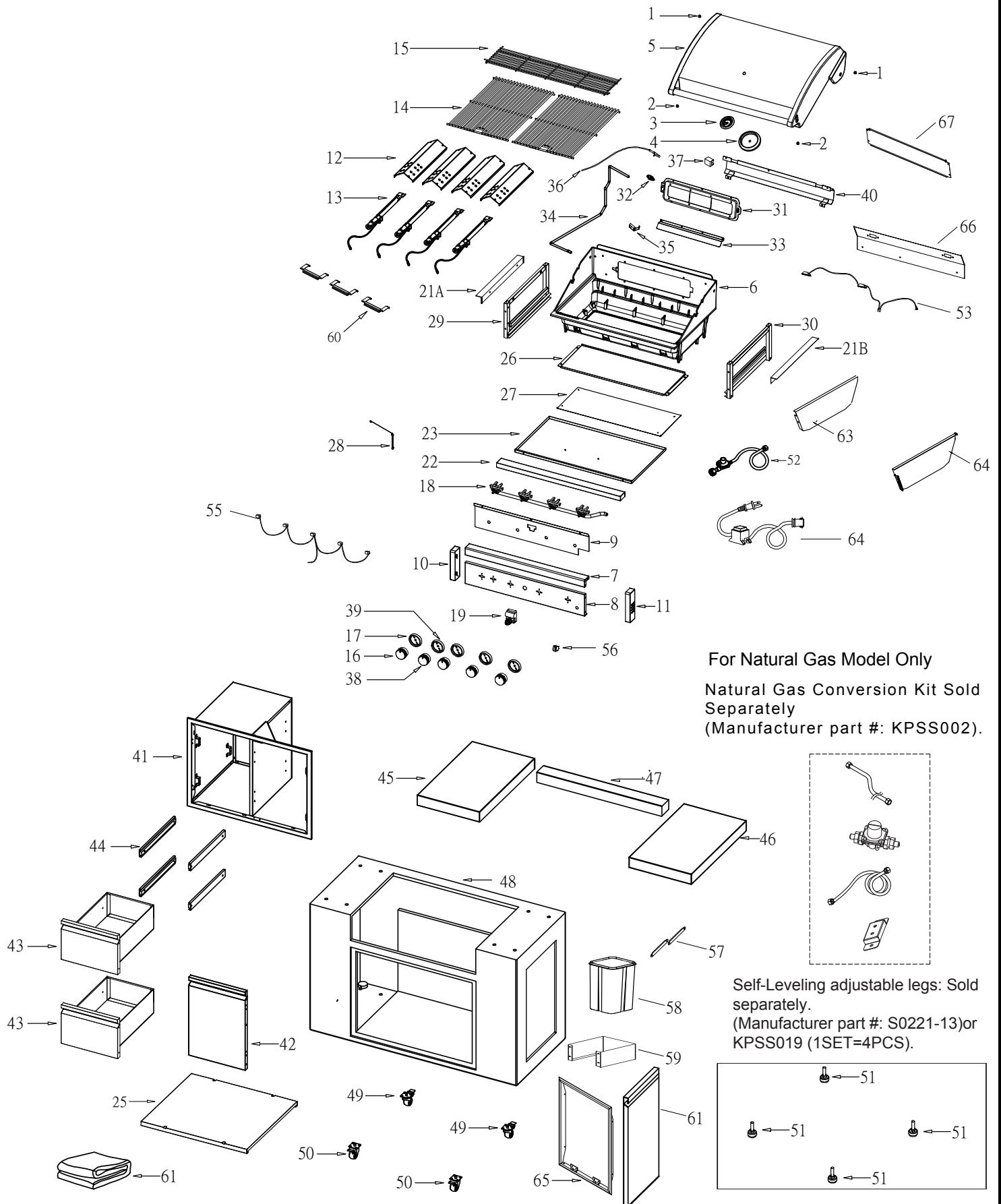

## Part Diagrams and Lists-BS04RCIS-LP-D

KEY	DESCRIPTION	PART#	QTY
1	Protective Pad,Rear	S0111-160	2
2	Protective Pad,Front	S0111-160	2
3	Temperature Gauge	S0209-16	1
4	Thermometer Bezel	S0202-19	1
5	Lid Assembly	S0226-01Z	1
6	Cast Aluminum Grill Box	S0224-01	1
7	Control Panel,Upper	S0226-02	1
8	Control Panel,Lower	S0230-12	1
9	Gas Valve Heat Shield Panel	S0224-04	1
10	Control panel end cap, Left	S0224-05A	1
11	Control panel end cap, Right	S0224-05B	1
12	Flame Tamers	S0224-06	4
13	Main Burner	S0224-07	4
14	Cooking Grid	S0224-08	2
15	Warming Rack	S0224-09	1
16	Conctrol Knob	S0224-61	4
17	Control knob Bezel	S0202-22	4
18	Gas Valve/ Manifold Assembly	S0224-79	1
19	Electric Ignitor,6-port	M0126-65	1
21A	Built-in Bracket, Left	S0224-73	1
21B	Built-in Bracket, Right	S0224-74	1
22	Grease Tray Handle, Main Firebowl	S0224-10	1
23	Main Firebox Grease Tray	S0224-11-S30406	1
25	Bottom Shelf , Left Cabined-LP/NG	S0230-09	1
26	Grease tray Heat Shield Panel -Upper	S0224-13	1
27	Grease tray Heat Shield Panel -Lower	S0224-14	.
28	Lighting Stick	S0202-45	1
29	Bowl Panel,Left	S0224-15Z1	1
30	Bowl Panel,Right	S0224-15Z2	1
31	Rear Burner Assembly	S0224-18Z1	1
32	Rear Burner Valve Orifice	S0211-39	1
33	Rear Burner Wind Shield Bracket	M0126-56	1
34	Rotisserie Burner Extension Tube	S0224-98	1
35	Rotisserie Burner Electrode	S0003-54	1
36	Rear Burner Thermocouple	S0224-99	1
37	Rotisserie Burner Thermocouple Bracket	S0056-56	1
38	Control knob for Rotisserie Burner	S0158-30	1
39	Control knob Bezel	S0202-22	1
40	Rotisserie Burner Wind Shield Panel	S0224-65	1
41	Door Trim Plate	S0224-27	1
42	Door,Tank Storage	S0224-28	1
43	Door Assembly	S0224-34Z2	2
44	Drawer slide Set	S0205-45	2 set
45	Countertop, Left	S0230-16	1
46	Countertop, Right	S0230-17	1
47	Countertop, Rear	S0230-18	1
48	Stacked Stone Island Bench	S0230-13	1
49	Caster with brake	S0224-21A	2
50	Caster without brake	S0224-21B	2
51	Adjustable leveling legs (Sold separately)	S0221-13	4

## Part Diagrams and Lists-BS04RCIS-LP-D

KEY	DESCRIPTION	PART#	QTY
52	Regulator With Hose Assembly	S0207-100	1
53	Light	S0230-19	1 set
54	Transformer	S0234-04	1
55	Electric Wire Set	S0234-05	1 set
56	Switch for Light	S0234-06	1
57	Door Latch	S0202-10	2
58	Trash Bin	S0202-47	1
59	Trash Bin Holder	S0202-46	1
60	Crossfire box	S0225-07Z	3
61	Door,Right	S0224-24-Z1	1
62	Grill Cover	KGC0008A	1
63	Inner Fire Bowl Panel, Left	S0230-10A	1
64	Inner Fire Bowl Panel, Right	S0230-10B	1
65	Door Trim Plate, Right	S0224-23	1
66	Bracket for Lights	S0230-15	1
67	Wind Shield Panel	S0230-14	1

# Part Diagrams and Lists-BS04-BI-LP

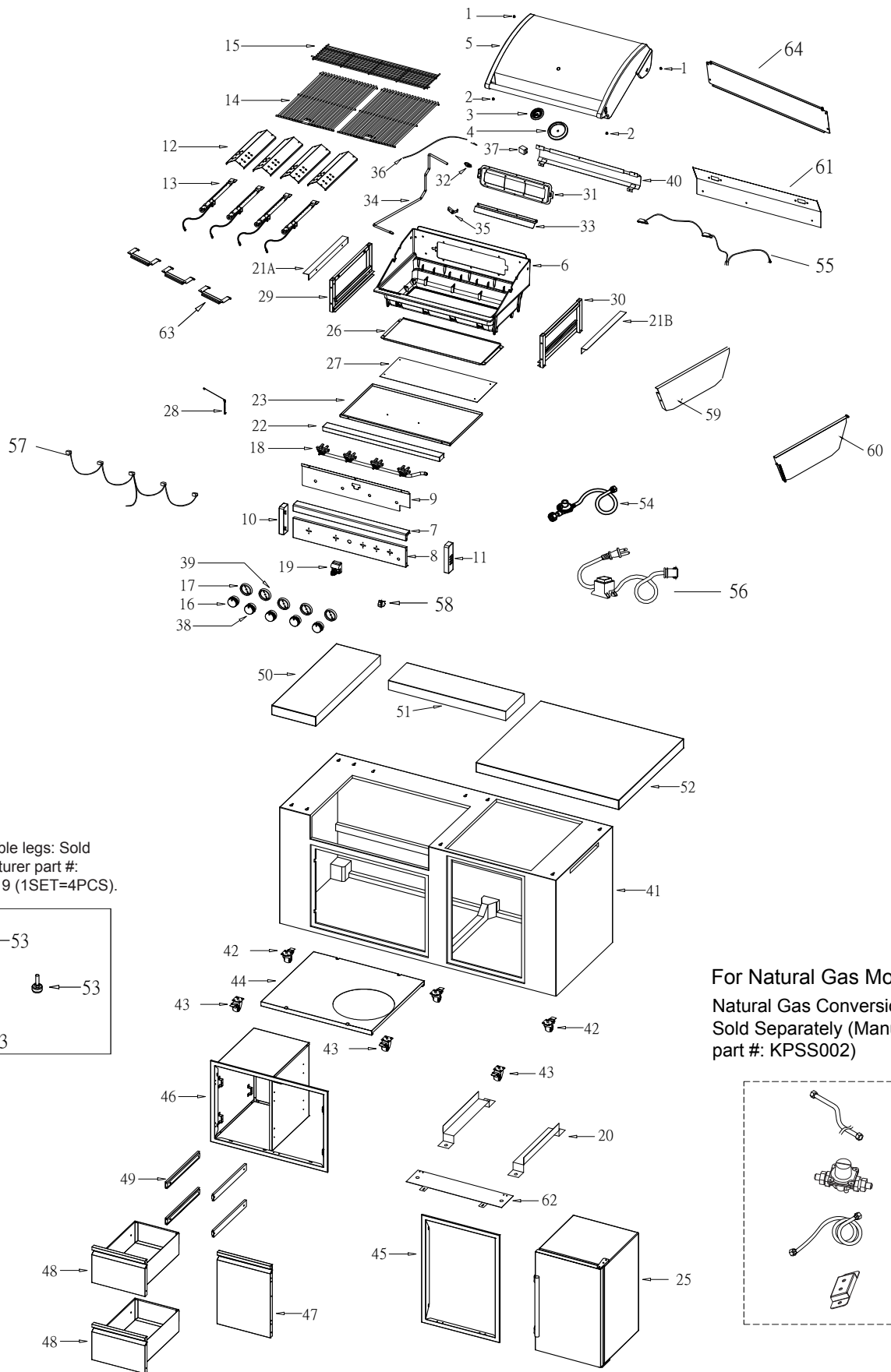

Self-Leveling adjustable legs: Sold separately. (Manufacturer part #: S0221-13 or KPSS019 (1SET=4PCS)).

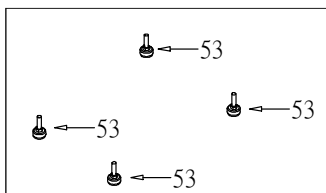

For Natural Gas Model Only  
Natural Gas Conversion Kit  
Sold Separately (Manufacturer part #: KPSS002)

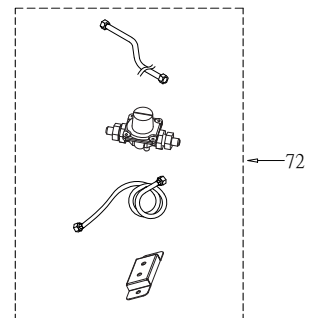

## Part Diagrams and Lists-BS04-BI-LP

KEY	DESCRIPTION	PART#	QTY
1	Protective Pad,Rear	S0111-160	2
2	Protective Pad,Front	S0111-160	2
3	Temperature Gauge	S0209-16	1
4	Thermometer Bezel	S0202-19	1
5	Lid Assembly	S0226-01Z	1
6	Cast Aluminum Grill Box	S0224-01	1
7	Control Panel,Upper	S0226-02	1
8	Control Panel,Lower	S0230-12	1
9	Gas Valve Heat Shield Panel	S0224-04	1
10	Control panel end cap, Left	S0224-05A	1
11	Control panel end cap, Right	S0224-05B	1
12	Flame Tamers	S0224-06	4
13	Main Burner	S0224-07	4
14	Cooking Grid	S0224-08	2
15	Warming Rack	S0224-09	1
16	Conctrol Knob	S0224-61	4
17	Control knob Bezel	S0202-22	4
18	Gas Valve/ Manifold Assembly	S0224-79	1
19	Electric Ignitor,6-port	M0126-65	1
20	Fridge Bracket	S0226-05-S30415	2
21A	Built-in Bracket, Left	S0224-73	1
21B	Built-in Bracket, Right	S0224-74	1
22	Grease Tray Handle, Main Firebowl	S0224-10	1
23	Main Firebox Grease Tray	S0224-11-S30406	1
25	Fridge	S0226-13	1
26	Grease tray Heat Shield Panel -Upper	S0224-13	1
27	Grease tray Heat Shield Panel -Lower	S0224-14	1
28	Lighting Stick	S0202-45	1
29	Bowl Panel,Left	S0224-15Z1	1
30	Bowl Panel,Right	S0224-15Z2	1
31	Rear Burner Assembly	S0224-18Z1	1
32	Rear Burner Valve Orifice	S0211-39	1
33	Rear Burner Wind Shield Bracket	M0126-56	1
34	Rotisserie Burner Extension Tube	S0224-98	1
35	Rotisserie Burner Electrode	S0003-54	1
36	Rear Burner Thermocouple	S0224-99	1
37	Rotisserie Burner Thermocouple Bracket	S0056-56	1
38	Control knob for Rotisserie Burner	S0158-30	1
39	Control knob Bezel	S0202-22	1
40	Rotisserie Burner Wind Shield Panel	S0224-65	1
41	Stacked Stone Island Bench	S0226-03	1
42	Caster with brake	S0224-21A	3
43	Caster without brake	S0224-21B	3

## Part Diagrams and Lists-BS04-BI-LP

KEY	DESCRIPTION	PART#	QTY
44	Bottom Shelf ,Left Cabinet-LP/NG	S0224-22	1
45	Door Trim Plate	S0224-23Z2	1
46	Door Trim Plate	S0224-27	1
47	Door, Tank Storage	S0224-28	1
48	Drawer Assembly	S0224-34Z2	2
49	Drawer Slide set	S0205-45	2 set
50	Countertop, Left	S0224-52	1
51	Countertop, Rear	S0224-53	1
52	Countertop, Right	S0226-06	1
53	Adjustable leveling legs (Sold separately)	S0221-13	4
54	Regulator With Hose Assembly	S0207-100	1
55	Light	S0230-19	1 set
56	Transformer	S0234-04	1
57	Electric Wire Set	S0234-05	1
58	Switch for Light	S0234-06	1
59	Inner Fire Bowl Panel, Left	S0230-10A	1
60	Inner Fire Bowl Panel, Right	S0230-10B	1
61	Bracket for Lights	S0230-15	1
62	Fridge Bracket - front	S0226-12	1
63	Crossfire box	S0225-07Z	3
64	Wind Shield Panel	S0230-14	1

### Natural Gas Conversion Kit Sold Separately

72	Natural Gas Conversion Kit (Sold Separately)	KPSS002	1

# Part Diagrams and Lists-Drawer Set

KEY	DESCRIPTION	PART#	QTY
1	Door Trim Frame	S0224-27	1
2	Door, Tank Storage	S0224-28Z	1
3	Drawer Assembly	S0224-34Z	2
4	Drawer Slide set	S0205-45	2 set

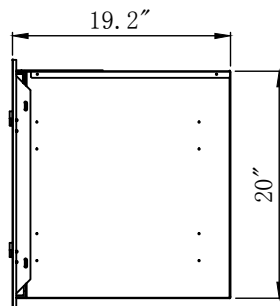
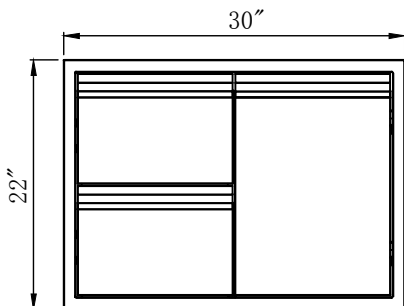
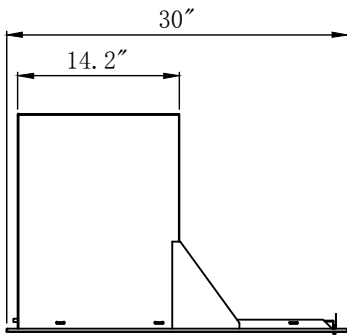
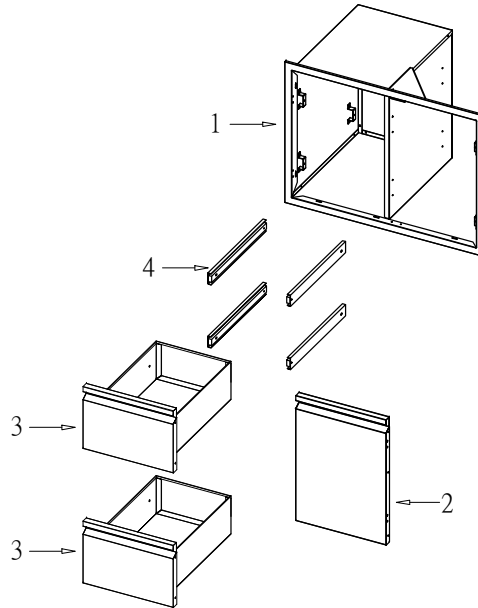

# Part Diagrams and Lists-BS04RFIS-LP-B

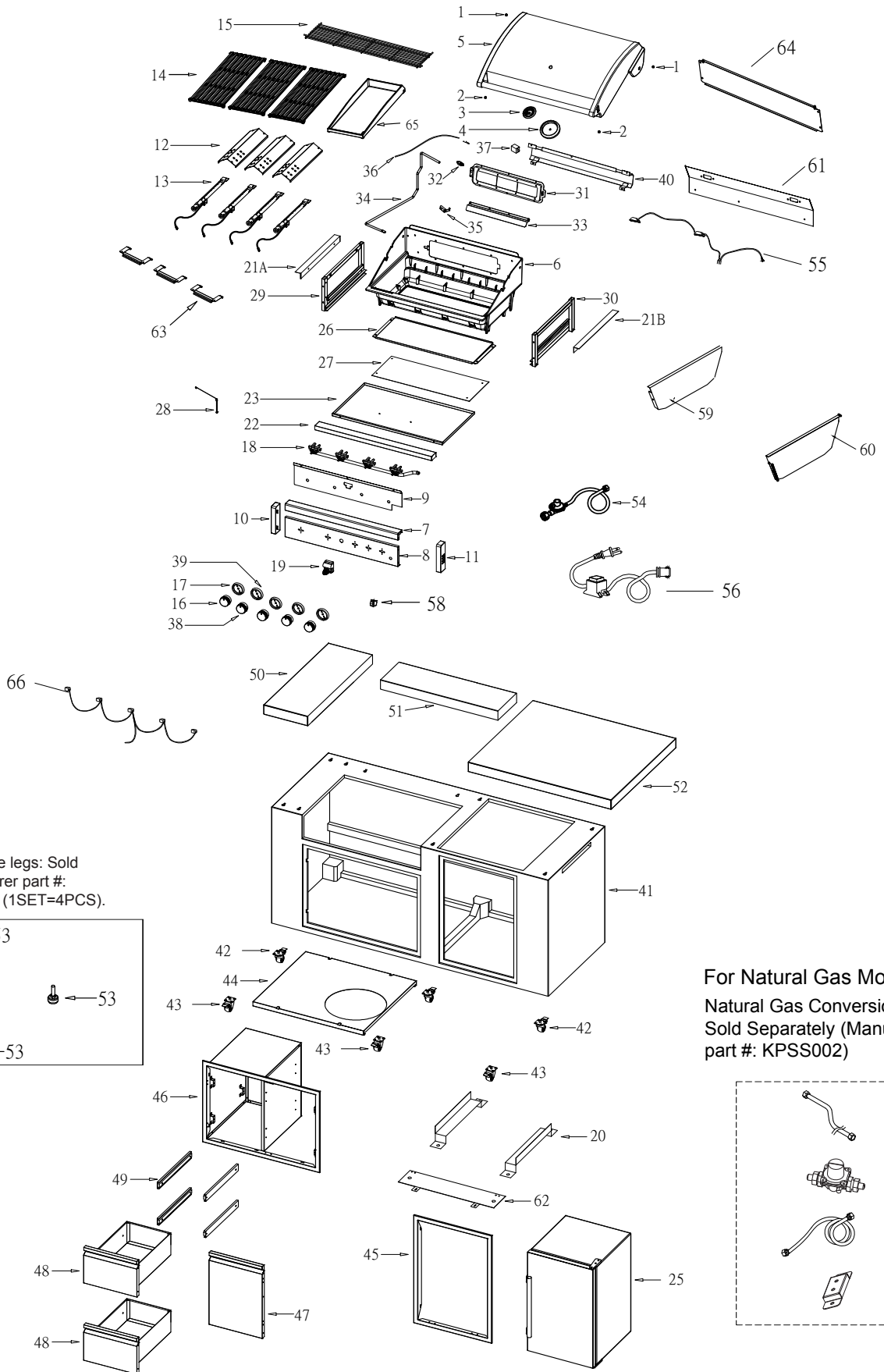

Self-Leveling adjustable legs: Sold separately. (Manufacturer part #: S0221-13 or KPSS019 (1SET=4PCS)).

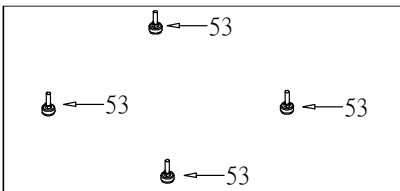

For Natural Gas Model Only  
Natural Gas Conversion Kit  
Sold Separately (Manufacturer part #: KPSS002)

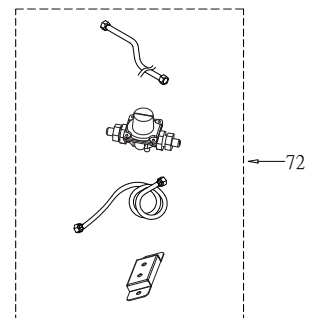

## Part Diagrams and Lists-BS04RFIS-LP-B

KEY	DESCRIPTION	PART#	QTY
1	Protective Pad,Rear	S0111-160	2
2	Protective Pad,Front	S0111-160	2
3	Temperature Gauge	S0209-16	1
4	Thermometer Bezel	S0202-19	1
5	Lid Assembly	S0226-01Z	1
6	Cast Aluminum Grill Box	S0224-01	1
7	Control Panel,Upper	S0226-02	1
8	Control Panel,Lower	S0230-12	1
9	Gas Valve Heat Shield Panel	S0224-04	1
10	Control panel end cap, Left	S0224-05A	1
11	Control panel end cap, Right	S0224-05B	1
12	Flame Tamers	S0224-06	3
13	Main Burner	S0224-07	4
14	Cooking Grid	S0225-01B	3
15	Warming Rack	S0224-09	1
16	Conctrol Knob	S0224-61	4
17	Control knob Bezel	S0202-22	4
18	Gas Valve/ Manifold Assembly	S0224-79	1
19	Electric Ignitor,6-port	M0126-65	1
20	Fridge Bracket	S0226-05-S30415	2
21A	Built-in Bracket, Left	S0224-73	1
21B	Built-in Bracket, Right	S0224-74	1
22	Grease Tray Handle, Main Firebowl	S0224-10	1
23	Main Firebox Grease Tray	S0224-11-S30406	1
25	Fridge	S0226-13	1
26	Grease tray Heat Shield Panel -Upper	S0224-13	1
27	Grease tray Heat Shield Panel -Lower	S0224-14	1
28	Lighting Stick	S0202-45	1
29	Bowl Panel,Left	S0224-15Z1	1
30	Bowl Panel,Right	S0224-15Z2	1
31	Rear Burner Assembly	S0224-18Z1	1
32	Rear Burner Valve Orifice	S0211-39	1
33	Rear Burner Wind Shield Bracket	M0126-56	1
34	Rotisserie Burner Extension Tube	S0224-98	1
35	Rotisserie Burner Electrode	S0003-54	1
36	Rear Burner Thermocouple	S0224-99	1
37	Rotisserie Burner Thermocouple Bracket	S0056-56	1
38	Control knob for Rotisserie Burner	S0158-30	1
39	Control knob Bezel	S0202-22	1
40	Rotisserie Burner Wind Shield Panel	S0224-65	1
41	Stacked Stone Island Bench	S0226-21	1
42	Caster with brake	S0224-21A	3
43	Caster without brake	S0224-21B	3

## Part Diagrams and Lists-BS04RFIS-LP-B

KEY	DESCRIPTION	PART#	QTY
44	Bottom Shelf ,Left Cabinet-LP/NG	S0224-22	1
45	Door Trim Plate	S0224-23Z2	1
46	Door Trim Plate	S0224-27	1
47	Door, Tank Storage	S0224-28	1
48	Drawer Assembly	S0224-34Z2	2
49	Drawer Slide set	S0205-45	2 set
50	Countertop, Left	S0224-52	1
51	Countertop, Rear	S0224-53	1
52	Countertop, Right	S0226-06	1
53	Adjustable leveling legs (Sold separately)	S0221-13	4
54	Regulator With Hose Assembly	S0207-100	1
55	Light	S0230-19	1 set
56	Transformer	S0234-04	1
58	Switch for Light	S0234-06	1
59	Inner Fire Bowl Panel, Left	S0230-10A	1
60	Inner Fire Bowl Panel, Right	S0230-10B	1
61	Bracket for Lights	S0230-15	1
62	Fridge Bracket - front	S0226-12	1
63	Crossfire box	S0225-07Z	3
64	Wind Shield Panel	S0230-14	1
65	Hot plate	S0225-02B	1
66	Electric Wire Set	S0234-05	1

### Natural Gas Conversion Kit Sold Separately

72	Natural Gas Conversion Kit (Sold Separately)	KPSS002	1

# WARNING



## WARNING



- This appliance, when installed, must be electrically grounded in accordance with local codes or, in the absence of local codes, with the *National Electrical Code, ANSI/NFPA 70*, or the *Canadian Electrical Code, CSA C22.1*.
- Keep any electrical supply cord and the fuel supply hose away from any heated surfaces.



## WARNING



1. **Do not store or use gasoline or other flammable liquids or vapors in the vicinity of this or any other appliances.**
2. **An LP cylinder not connected for use shall not be stored in the vicinity of this or any other appliance.**



## WARNING



Should a FLASHBACK fire occur in or around the Burner Tubes, follow the instructions below. Failure to comply with these instructions could result in a fire or explosion that could cause serious bodily injury, death, or property damage.

- Shut off gas supply to the gas grill.
- Turn the Control Knobs to OFF position.
- Open the Grill Lid.
- Put out any flame with a Class B fire extinguisher.
- Once the grill has cooled down, clean the Burner Tubes and Burners according to the cleaning instructions in this Use and Care Guide.



## WARNING



If ignition does not occur in 5 seconds, turn the Control Knob(s) and gas source OFF and conduct a leak test as explained in the Use and Care section of this guide. If no leaks are detected, wait 5 minutes for any gas to clear and repeat the lighting procedure.



## WARNING



- LPG models must be used with Liquid Propane Gas and the regulator assembly supplied. Natural Gas models must be used with Natural Gas only. Any attempt to convert the grill from one fuel type to another is extremely hazardous and will void the warranty.
- Keep gas regulator hose away from hot grill surfaces and dripping grease. Avoid unnecessary twisting of hose. Visually inspect hose prior to each use for cuts, cracks, excessive wear or other damage. If the hose appears damaged do not use the gas grill. Call 1-877-419-2598; email: [support@1800acs.com](mailto:support@1800acs.com)/[contact@zhprokan.com](mailto:contact@zhprokan.com) for a certified replacement hose.
- **State of California Proposition 65 Warnings:**  
 **WARNING:** This product can expose you to chemicals including carbon monoxide, soot, lead, and lead component, which are known to the State of California to cause cancer and birth defects or other reproductive harm. For more information go to [www.P65Warnings.ca.gov](http://www.P65Warnings.ca.gov).
- **Never use charcoal** or lighter fluid in this gas grill. Failure to comply with these instructions could result in a grease fire or explosion that could cause serious bodily injury, death or property damage.
- **Before each use of your grill:** Inspect the Grease Tray, Flame Tamer and inside of the Grill Bowl to be sure there is no excessive grease and debris buildup. Clean the Grease Tray, Flame Tamer and inside of the Grill Bowl frequently to eliminate grease/debris buildup and to prevent grease fires. **Failure to comply with these instructions could result in a grease fire and even a subsequent explosion that could cause serious bodily injury, death or property damage.**



## WARNING



**Never store flammable liquids or materials in the drawer(s). Failure to comply with these instructions could result in a fire or explosion that could cause serious bodily injury, death, or property damage.**



## DANGER



**Do not use an open flame to check for gas leaks. Be sure there are no sparks or open flames in the area while you check for gas leaks. This will result in a fire or explosion which can cause serious bodily injury or death, and damage to property.**



## DANGER



**If you smell gas:**

- 1. Shut off gas to the appliance.**
- 2. Extinguish any open flame.**
- 3. Open lid.**
- 4. If odor continues, keep away from the appliance and immediately call your gas supplier or your fire department.**



## DANGER



**NEVER** cover slots, holes, or passages in the grill bowl bottom or cover an entire rack with material such as aluminum foil. Doing so blocks air flow through the grill and may cause carbon monoxide poisoning. Aluminum foil linings may trap heat causing a fire hazard. If the instructions above are not followed exactly, a fire may be causing death or serious injury.



## DANGER



**Your grill will get very hot.** Never lean over the cooking area while using your grill. Do not touch cooking surfaces, grill housing, grill lid or any other grill parts while the grill is in operation, or until the grill has cooled after use. **Failure to comply with these instructions may result in serious bodily injury.**

# Troubleshooting

## Troubleshooting

### If the grill fails to light :

1. Turn gas off at source and turn Control Knobs to OFF. Wait at least 5 minutes for gas to clear, then retry.
2. If your grill still fails to light, check gas supply and connections.
3. Repeat lighting procedure. If your grill still fails to operate, turn the gas off at source, turn the Control Knobs to OFF, then check the following:

- Misalignment of Burner Tubes over Orifices

**Correction:** Reposition Burner Tubes over Orifices.

- Obstruction in gas line

**Correction:** Remove fuel line from grill. Do not smoke! Open gas supply for one second to clear any obstruction from fuel line. Close off gas supply at source and reconnect fuel line to grill.

- Plugged Orifice

**Correction:** Remove Burners from grill by removing the screw from the rear of each Burner using Phillips Head Screwdriver. Carefully lift each Burner up and away from gas valve Orifice. Remove the Orifice from gas valve and gently clear any obstruction with a fine wire. Then reinstall all Orifices, Burners, screws and cooking components.

- If an obstruction is suspected in Gas Valves or Manifold, call the Grill Information Center 1-866-2862720 ; Monday - Friday 8:00am-4:30pm CST
- Obstruction in Burner Tubes

**Correction:** Follow the Burner Tube cleaning procedure on **page 4.** of this Operator's Manual.

- Misalignment of Ignitor on Burner

**Correction:** Check for proper position of the Electrode Tip as shown in **step 6 & 7 on page 16.** The gap between the Spark Electrode Tip and Spark Receiver should be approximately 3/16" wide. Adjust if necessary. With the gas supply closed and all Control Knobs set to OFF, press the Electric Ignitor cap and watch for the presence of a spark at the end of the Electrode.

- Disconnected Electric Wires

**Correction:** Inspect the Ignitor Junction Box found behind the Control Panel. Connect loose Electric wires to Junction Box and try to light the grill.

- Weak AA battery

**Correction:** Remove the Ignitor Cap and replace the battery.

- If the grill still does not light you may need to purge air from the gas line or reset the regulator excess gas flow device. **Note:** This procedure should be done every time a new LP Gas tank is connected to your grill.

### To purge air from your gas line and/or reset the regulator excess gas flow device:

- Turn Control Knobs to the OFF position.
- Turn off the gas at the tank valve.
- Disconnect regulator from LP Gas tank.
- Let unit stand 5 minutes to allow air to purge.
- Reconnect regulator to the LP Gas tank.
- Turn tank valve on SLOWLY 1/4 of a turn.
- Open the Grill Lid.
- Push and turn the Left Main Burner Control Knob to IGN/HIGH.
- Press Electric Ignitor for 3-4 seconds to light the burners.

# Troubleshooting

## Question:

**Can I convert my grill from LPG to NG?**

## Answer:

No, your gas grill is manufactured to exact specifications and is certified for Liquid Propane (LPG) or Natural Gas (NG) use only. For your safety, conversion kits are not available. Any attempt to convert your grill will void your warranty.

## Question:

**Are the serial and model numbers of my grill listed somewhere for reference?**

## Answer:

The serial and model numbers are listed on a **SGS** label which is placed on the grill. For this model, the **SGS** label is located on the right door panel.

## Question:

**My grill will not light properly. Why?**

## Answer:

Always light the Main Burner farthest from the fuel source first. This will draw gas across the manifold helping prevent air pockets which obstruct gas-flow and prevent proper grill lighting. Also try this procedure:

1. Turn gas off at source and turn Control Knobs OFF. Wait at least 5 minutes for gas to clear, then retry.
2. If your grill still fails to light, turn the Burner Control Knob(s) and gas source OFF and conduct a leak test of ALL gas connections and gas sources as explained in the Use and Care section of this manual.
3. If no leaks are detected, wait 5 minutes for any gas to clear and repeat the lighting procedure.

## Question:

**If my ignitor or battery is not working how can I light my grill manually? And - Why would I need the lighting stick that was supplied with my grill?**

## Answer:

If your ignition fails to work or your battery needs replacing, you can manually light your grill by paper match. Insert a paper match into the Lighting Stick and follow the Manual Grill Lighting Instructions. Then, light the match and place Lighting Stick through a Cooking Grid. Turn the correlated Control Knob to the HIGH setting to release gas. The Burner should light immediately.



## CAUTION



**Never** lean over the grill cooking area while lighting your gas grill. Keep your face and body a safe distance (at least 18 inches) from the front of grill when lighting your grill by match.

## Question:

**Sometimes I hear a humming sound coming from my regulator. What causes this? And - My grill has a low flame and sometimes will not light. Why?**

## Answer:

The humming sound is gas flowing through the regulator. A low volume of sound is normal and will not interfere with the operation of your grill. Loud or excessive regulator humming and/or low flow and intermittent lighting may be caused by the regulator's excess gas flow device. Opening the tank valve all the way or too quickly is what triggers the regulator's safety device to restrict gas flow, preventing excess gas flow to your grill. Lighting the main Burner farthest from the fuel source every time will help eliminate air pockets in the manifold. Note: This procedure should be done every time a new LP Gas tank is connected to your grill.

- Turn all Control Knobs to the OFF position.
- Turn off the LP Gas tank at the tank valve.
- Disconnect regulator from LP Gas tank.
- Let unit stand for 5 minutes.
- Reconnect regulator to the LP Gas tank.
- Open grill Lid (or Side Burner Lid if you are lighting the Side Burner).
- Turn the tank valve slowly ¼ of one turn.
- Light main Burner farthest from fuel source.
- Turn the tank valve slowly one more ¼ of one turn for ½ of one complete turn.
- Continue to light Burners moving towards the fuel source.
- Do not turn tank valve more than ½ of one turn on LPG models.

## Question:

**Where do I use my grill for safer operation and better performance?**

## Answer:

- Strong winds and low temperatures can affect the heating and performance of your gas grill so factor in these elements when positioning your grill outdoors for cooking.
- In **windy conditions**, always position the front of the grill to face oncoming wind to reduce heat and smoke from blowing in your face and to prevent potential serious injury or grill damage.
- Use your grill at least 3 feet away from any wall or surface.
- Use your grill at least 3 feet away from combustible objects that can melt or catch fire (ex: vinyl or wood siding, fences and overhangs) or sources of ignition including pilot lights on water heaters and live electrical appliances.
- Never** use your gas grill in a garage, porch, shed, breezeway or any other enclosed area.
- Never** obstruct the flow of ventilation air around your gas grill housing.
- Never** use your gas grill on a balcony, deck, or patio above the ground floor of your home.

# Troubleshooting

**Question:**

**The Regulator and Hose supplied with my gas grill does not fit the older LP Gas tank I've used for years. Why not?**

**Answer:**

The U.S. Government regulates gas appliances and LP Gas tanks. When regulations are changed the LP Gas tank fittings are altered to insure compliance. If your LP Gas tank does not fit the Regulator and Hose supplied with your new grill, the tank is outdated and must be replaced. Note: Effective April 1, 2002 all LP Gas tanks sold must include an "OPD" Overfill Prevention Device. The OPD tanks are identified by their triangular-shaped valve wheel. This internal device prevents the LP Gas tank from being overfilled. Tanks without an OPD valve can not be refilled.

After every use (after your grill has cooled down), wipe stainless surfaces with a soft, soapy cloth or sponge then rinse with water. Be sure to remove all food particles, sauces or marinades from stainless steel because these can be highly acidic and damaging to stainless surfaces.

Never use abrasive cleaners, scrubbers or stiff wire brushes of any type on your grill. Use a heat resistant Stainless Steel Cleaner and rub or wipe in the direction of the stainless steel grain or polish lines. Do not polish against the grain.

**Question:**

**What causes grill parts to rust and what effect does it have on my grill?**

**Answer:**

Rusting is a natural oxidation process and will not affect the short term performance of your grill.

To slow the rusting process on Cooking Grids, we recommend greasing the grids before and after each cookout. Use a brush to apply a thin layer of cooking oil or vegetable shortening onto each grid. We do not suggest spray type oils unless they are specified for high-temperature cooking. If your Cooking Grids are Porcelain coated, be sure to coat the entire cooking surface including edges and any areas with chipped porcelain.

Routine care and maintenance is required to preserve the appearance and corrosion resistance of stainless steel. The fact is stainless steel can corrode, rust and discolor under certain conditions. Rust is caused when regular steel particles in the atmosphere become attached to the stainless steel surface. Steel particles can also become attached to your grill if you use steel wool or stiff wire brushes to clean the grill instead of non-abrasive cloth, sponge or nylon cleaning tools. In coastal areas rust pits can develop on stainless surfaces that cannot be fully removed. Bleach and other chlorine based solutions used for household and pool cleaning can also cause corrosion to stainless steel.



Weathering, extreme heat, smoke from cooking and machine oils used in the manufacturing process of stainless steel can cause stainless steel to turn tan in color. Although there are many factors which can affect the surface appearance of stainless steel, they do not affect the integrity of the steel or the performance of the grill. To help maintain the finish of stainless steel follow these cleaning procedures for the best results:

# Care & Use Instructions

## CORRECT LP GAS TANK USE

- LP Gas grill models are designed for use with a standard 20 lb. Liquid Propane Gas (LP Gas) tank (sold separately). **Never** connect your gas grill to an LP Gas tank that exceeds this capacity. A tank of approximately 12 inches in diameter by 18-1/2 inches high is the maximum size LP Gas tank to use. **You must use an "OPD" gas tank which offers a listed Overfill Prevention Device.** This safety feature prevents tank from being overfilled which can cause a malfunction of the LP Gas tank.
- The LP Gas tank must be constructed and marked in accordance with the Specifications for LP-Gas Cylinders of the U.S. Department of Transportation (D.O.T.) or the National Standard of Canada, CAN/CSA-B339, Cylinders, Spheres and Tubes for Transportation of Dangerous Goods; and Commission, as applicable.
- The LP Gas tank must have a shutoff valve, terminating in an LP Gas supply tank valve outlet, that is compatible with a Type 1 tank connection device. The LP Gas tank must also have a safety relief device that has a direct connection with the vapor space of the tank.
- The tank supply system must be arranged for vapor withdrawal.
- The LP Gas tank must have a collar to protect the tank valve.
- Never connect an unregulated LP gas tank to your gas grill. The gas regulator assembly supplied with your gas grill is adjusted to have an outlet pressure of 11" water column (W.C.) for connection to an LP gas tank. Only use the regulator and hose assembly supplied with your gas grill. Replacement hose and regulator assembly must be identical to those listed in the parts list of this Operator's Manual as specified by the Manufacturer.
- Have your LP Gas dealer check the release valve after every filling to ensure it remains free of defects.
- Always keep LP Gas tank in upright position.
- Do not subject the LP Gas tank to excessive heat.
- Never store an LP Gas tank indoors. If you store your gas grill in the garage always disconnect the LP Gas tank first and store it safely outside.
- LP Gas tanks must be stored outdoors in a well-ventilated area and out of the reach of children.
- Disconnected LP Gas tanks must not be stored in a building, garage or any other enclosed area.
- The regulator and hose assembly can be seen after opening the right cabinet door and must be inspected before each use of the grill. If there is excessive abrasion or wear or if the hose is cut, it must be replaced prior to using the grill again
- Any attempt to convert the grill from one fuel type to another is extremely hazardous and must be performed by a qualified gas technician only, using a NG Conversion Kit purchased from Manufacturer.
- Never light your gas grill with the lid closed or before checking to ensure the burner tubes are fully seated over the gas valve orifices.
- Never allow children to operate your grill. Do not allow children or pets to play near your grill. Always supervise children and pets if they are in the vicinity of the unit.
- Use of alcohol, prescription or non-prescription drugs can impair your ability to properly assemble and safely operate your grill.



- Keep fire extinguisher readily accessible. In the event of a oil/grease fire, do not attempt to extinguish with water. Use type B extinguisher or smother with dirt, sand or baking soda.
- In the event of rain, turn off the burners and gas supply. Wait for the grill to cool, and then place a cover on it.
- Use your grill on a level, stable surface in an area clear of combustible materials.
- Do not leave grill unattended when in use.
- Do not move the appliance when in use.
- Allow the grill to cool before moving or storing.
- Do not use your grill as a heater.
- This grill is not intended to be installed in or on recreational vehicles and/or boats.
- The grill is not intended for commercial use.
- Never** use charcoal or lighter fluid in this grill.
- Please protect your grill with grill cover when not in use. keep in mind that only use the cover when grill is in cold condition.

**CAUTION**

A. Do not store a spare LP-Gas tank under or near this appliance.

B. Never fill the tank beyond 80 percent full; and

C. If the information in "(a)" and "(b)" is not followed exactly, a fire causing death or serious injury may occur.

**CAUTION**

- Use your grill at least 36 inches away from any wall or surface.
- Use your grill 36 inches away from any combustible objects that can melt or catch fire such as vinyl or wood siding, fences, overhangs (See Diagram Be-low), or any other sources of ignition; including pilot lights and live electrical appliances.
- Do not use your grill under any overhead combustible construction.
- Never use your gas grill in a garage, porch, shed, breezeway, or any other enclosed area.
- In windy conditions, always position the front of the grill to face oncoming wind to reduce heat and smoke blowing in your face, and to prevent potential hazards to yourself and the grill.

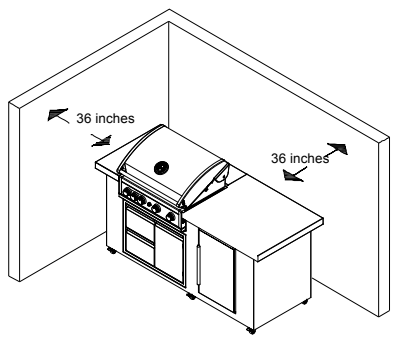

# Care & Use Instructions

## NOTE about LP Gas Tank Exchange Programs

- Many retailers who sell grills offer you the option of replacing your empty LP Gas tank through an exchange service. Use only those reputable exchange companies that inspect, precision fill, test, and certify their tanks. Exchange your tank only for an OPD safety feature-equipped tank as described in the LP Gas tank section of this Guide.
- Always keep new and exchanged LP Gas tanks in an upright position during use, transit or storage.
- Leak test new and exchanged LP Gas tanks BEFORE connecting one to your grill.

## How to Leak Test your LP Gas Tank For your safety:

- All leak tests must be repeated each time your LP Gas tank is exchanged or refilled.
- When checking for gas leaks do not smoke.

Do not use an open flame to check for gas leaks.

- Your grill must be leak tested outdoors in a well-ventilated area, away from ignition sources such as gas fired or electrical appliances. During the leak test, keep your grill away from open flames or sparks.
- Do not use household cleaning agents. Damage to gas assembly components can result.
  - Use a clean paintbrush and a 50/50 mild soap and water solution.
  - Brush soapy solution onto LP Gas tank in the areas indicated by the arrows. See diagram.
  - If growing bubbles appear do not use or move the LP Gas tank. Call an LP Gas Supplier or your Fire Department.

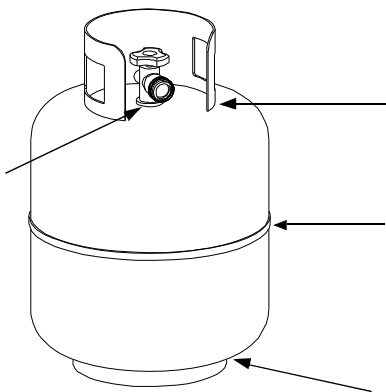

## LP Gas Model only: To Secure a 20lb LP Gas Tank to the tank storage

- Turn your LP Gas Tank Valve clockwise to the closed or OFF position.
- Open the door.
- Place LP Gas Tank into the Fuel Gauge Set on the right cabinet.
- Install the Tank so the Tank Valve faces the front left corner of Right Cabinet.
- Attach the Regulator with Hose to the gas tank. (Refer to the Regulator connection section on page 16)
- Set the Gas Tank securely on the Right Cabinet and tighten the wing bolt.

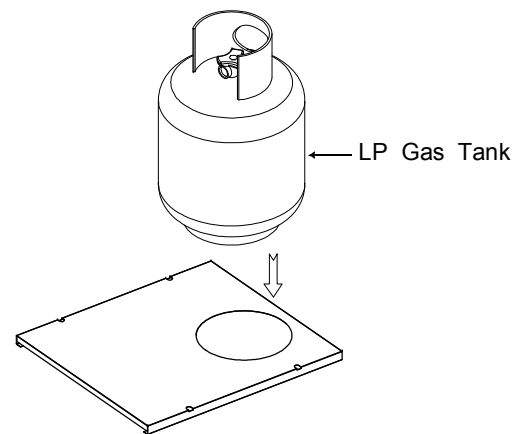
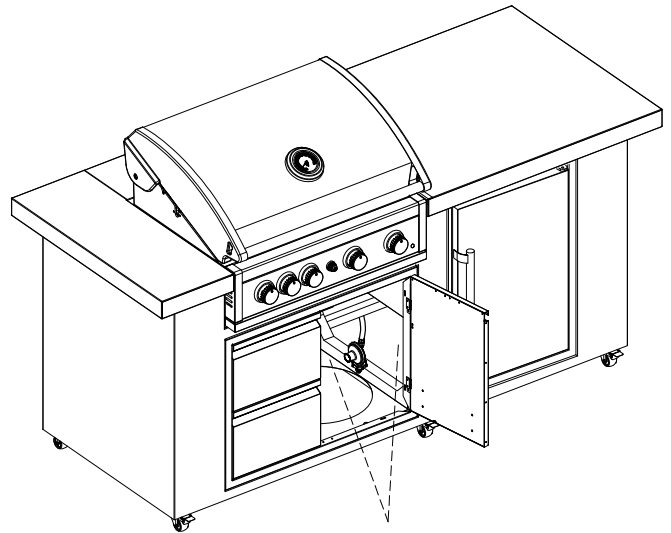



### CAUTION



If growing bubbles appear do not use or move the LP Gas tank. Contact an LP Gas Supplier or your fire department!

# Care & Use Instructions

## LP Gas Model only:

### Connect Regulator with Hose to your LP Gas Tank

- Turn all Burner Valves to the OFF position.
- Inspect the valve connection port and regulator assembly for damage or debris. Remove any debris. Never use damaged or plugged equipment.
- Connect the regulator assembly to the tank valve and HAND TIGHTEN nut clockwise to a full stop. DO NOT use a wrench to tighten because it could damage the Quick Coupling Nut and result in a gas leak/fire hazard.
- Open the tank valve (counterclockwise) 1/4 to 1/2 of a full turn, and use a soapy water solution to check all connections for leaks before attempting to light your grill. See "Check all connections for LP Gas Leaks". If a leak is found, turn the tank valve off and do not use your grill until the leak is repaired.

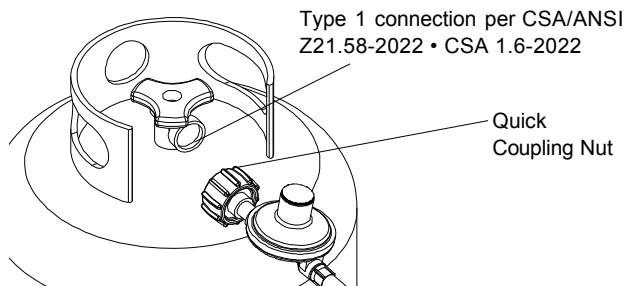

**CAUTION:** When the appliance is not in use, the gas must be turned off at the tank. Place dust cap on cylinder valve outlet whenever the cylinder is not in use. Only install the type of dust cap on the cylinder valve outlet that is provided with the cylinder valve. Other types of caps or plugs may result in leakage of propane.



If you have a gas leak that cannot be repaired by tightening, turn off the gas at the source, disconnect fuel line from your grill and call 1-877-419-2598 ; or your gas supplier for repair assistance.



1. Do not store spare LP cylinder within 10 feet (3m) of this appliance.
2. Do not store or use gasoline or other flammable liquids and vapors within 25 feet (8m) of this appliance.
3. When cooking with oil/grease, do not allow the oil/grease to get hotter 350°F (177°C)
4. Do not leave oil/grease unattended.

### Check all connections for LP Gas Leaks

Never test for leaks with an open flame. Prior to first use, at the beginning of each season, or every time your LP Gas tank is changed, you must check for gas leaks. Follow these three steps:

- Make a soap solution by mixing one part liquid detergent and one part water.
- Turn the grill Control Knobs to the full OFF position, then turn the gas ON at source.
- Apply the soap solution to all gas connections indicated by the arrows. See diagram. If bubbles appear in the soap solution the connections are not properly sealed. Check each fitting and tighten or repair as necessary.

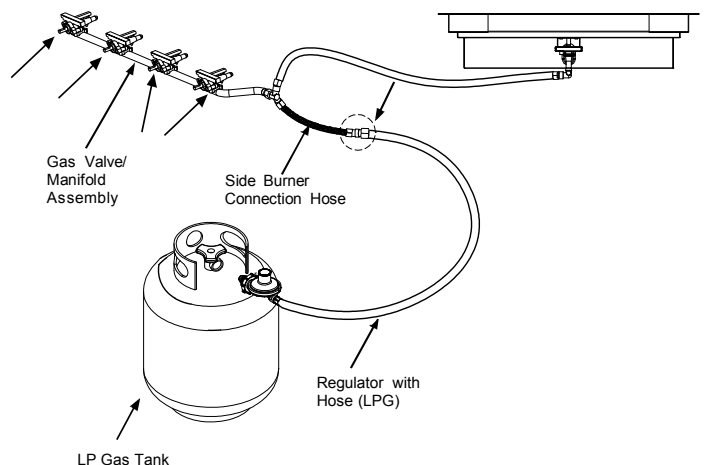

### Disconnecting A Liquid Propane Gas (LPG) Tank From Your Grill

- Make sure the Burner Valves and LP Gas tank valve are off. (Turn clockwise to close.)
- Detach the hose and regulator assembly from the LP Gas tank valve by turning the Quick Coupling Nut counterclockwise. Do not use a wrench or any tools when turning the Quick Coupling Nut.



Failure to read and follow the Use and Care Instructions could result in a fire or explosion that could cause serious bodily injury, death or property damage.

# Care & Use Instructions

## Main Burner Lighting Instructions

1. Before each use, check all hoses for cracks, nicks, cuts, burns or abrasions. If a hose is damaged in any way, do not use your grill before replacing the hose with an authorized part from the Parts List. Also make sure all gas supply connections are securely tightened.
2. Familiarize yourself with all Safety and Use and Care instructions in this manual. Do not smoke while lighting your grill or when checking the gas supply connections.
3. Be sure that the LP Gas tank is filled.
4. Open the Grill Lid before lighting.



**CAUTION**



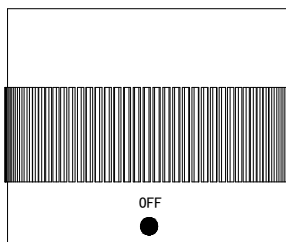

Failure to replace a faulty hose, secure gas supply connections or to open the Lid before proceeding to the Lighting Procedures could result in a fire or explosion that could cause serious bodily injury, death, or property damage.

5. Set Control Knobs to OFF and open the LP Gas tank valve **SLOWLY 1/4-1/2 of a full turn.**

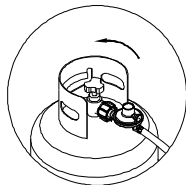

Open LP Gas tank



6. Push and turn Left Main Burner Control Knob to  (IGN/HIGH) and immediately press the electric ignitor button 3 to 4 seconds to light the burner.

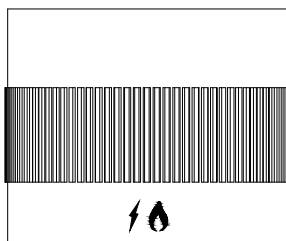

7. If ignition does not occur in 5 seconds, turn the Burner Control(s) off, wait 5 minutes, and repeat the lighting procedure. If ignition still does not occur, turn the burner control(s) and gas source OFF. Wait 5 minutes for gas to clear and then conduct a leak test of ALL gas connections and gas sources as explained in the Use and Care section of this manual. If no leaks are detected, wait 5 minutes for any gas to clear and repeat the lighting procedure.
8. After one Burner is lit, turn the tank valve SLOWLY one more 1/4 of a turn.

9. Repeat steps to light each burner individually. Note: When lighting all main burners, start with the burner furthest from fuel source location, then light remaining burners in sequence moving toward fuel source.

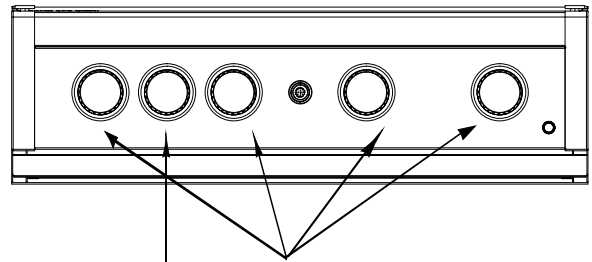

## Rotisserie Burner Lighting Instructions

1. Follow steps 1 through 5 of the Grill Lighting Instructions.
2. Then, push and turn the Rotisserie Burner Control Knob to  (IGN/HIGH) and hold knob in. Press the electric ignitor 3 to 4 seconds to light the burner. Once the burner is lit, continue to hold the knob in 10 seconds before releasing. If ignition does not occur follow step 7 before retrying.

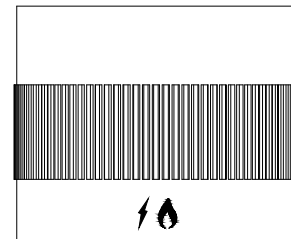

3. After the Rotisserie Burner is lit it will reach cooking temperature quickly. The orange/red glow will even out within minutes.

## Side Burner Lighting Instructions

1. Follow steps 1 through 5 of the Grill Lighting Instructions.
2. Push and turn Control Knob to  (IGN/HIGH).
3. The built-in spark ignitor will light the burner automatically.
4. You may have to push and turn the control knob up to 3 or 4 times to light.
5. If ignition does not occur in 5 seconds, turn the Burner Control off, wait 5 minutes, and repeat the lighting procedure. If ignition still does not occur, turn the burner control and gas source OFF. Wait 5 minutes for gas to clear and then conduct a leak test of ALL gas connections and gas sources as explained in the Use and Care section of this manual. If no leaks are detected, wait 5 minutes for any gas to clear and repeat the lighting procedure.

# Care & Use Instructions

Proper care and maintenance will keep your grill in top operating condition and prolong its life. Follow these cleaning procedures on a timely basis and your grill will stay clean and operate with minimum effort.

**CAUTION:** Be sure your grill is OFF and cool before cleaning.

## Cleaning the Cooking Grids

- Before initial use, and periodically thereafter, wash your Cooking Grids in a mild soap and warm water solution. You can use a wash cloth or vegetable brush to clean your Cooking Grids.

## Cleaning the Grease Tray

- To reduce the chance of fire, the Grease Tray should be visually inspected before each grill use. Remove any grease and wash Grease Tray with a mild soap and warm water solution.

## Cleaning the Inside of the Grill Lid

- Grease can build up on the inside of the Grill lid over time. This grease can drip onto your deck or patio when the lid is opened. Visually inspect the inside of the Grill Lid before each grill use. Remove any grease and wash with a mild soap and warm water solution.

## Routine Cleaning of The Grill Interior

- Burning-off excess food after every cookout will keep it ready for instant use. However, at least every 3 months you must give the entire grill a thorough cleaning to minimize your risk of grease fire and keep the grill in top shape. Follow these steps:
  1. Turn all Burner Valves to the full OFF position.
  2. Turn the LP gas tank valve to the full OFF position.
  3. Disconnect the regulator from the gas tank. Inspect the hose with regulator assembly for cracking, cuts or any other damage, and replace as necessary. Refer to the Parts List in this Operator's Manual.
  4. Remove and clean the Cooking Grids, Cooking Rack, Flame Tamers and Grill Burners.
  5. Cover each Gas Valve Orifice with aluminum foil.
  6. Brush the inside and bottom of the grill with a fiber pad or nylon brush and wash with a mild soap and warm water solution. Rinse thoroughly and let dry.
  7. Remove aluminum foil from Orifices and check each Orifice for obstruction.
  8. Check each Spark Electrode, adjusting as needed. The space between the Spark Electrode Tip and Spark Receiver should be approximately 3/16".
  9. Replace the Burners and adjust the Gas Collector Box. The edge of the collector box should be overlapping the Burner Port.
  11. Reconnect the gas source and observe the Burner flame for correct operation.
  10. Replace Flame Tamers, Cooking components.

## Cleaning Manufactured Stone Surfaces:

- If needed, we suggest you wash the manufactured stone surface using a mild soap and warm water solution only. You can use a soft soapy cloth or sponge then rinse with water. Never use abrasive cleaners, any cleaner containing bleach, scrubbers or stiff wire brushes on the stone surface. These can cause discoloration and /or chipping of the painted surface.

## Cleaning Exterior Stainless Steel Surfaces:

- Routine care and maintenance is required to preserve the appearance and corrosion resistance of stainless steel. The fact is stainless steel can corrode, rust and discolor under certain conditions. Rust is caused when regular steel particles in the atmosphere become attached to the stainless steel surface. Steel particles can also become attached to your grill if you use steel wool or stiff wire brushes to clean the grill instead of non-abrasive cloth, sponge or nylon cleaning tools. In coastal areas rust pits can develop on stainless surfaces that cannot be fully removed. Bleach and other chlorine based solutions used for household and pool cleaning can also cause corrosion to stainless steel. Weathering, extreme heat, smoke from cooking and machine oils used in the manufacturing process of stainless steel can cause stainless steel to turn tan in color. Although there are many factors which can affect the surface appearance of stainless steel, they do not affect the integrity of the steel or the performance of the grill.
- To help maintain the finish of stainless steel follow these cleaning procedures for the best results:
  1. After every use (after your grill has cooled down), wipe stainless surfaces with a soft, soapy cloth or sponge then rinse with water. Be sure to remove all food particles, sauces or marinades from stainless steel because these can be highly acidic and damaging to stainless surfaces.
  2. Never use abrasive cleaners, scrubbers or stiff wire brushes of any type on your grill.
  3. Use a heat resistant Stainless Steel Cleaner and rub or wipe in the direction of the stainless steel grain or polish lines. Do not polish against the grain.



## CAUTION



**Failure to comply with these instructions could result in a fire or explosion that could cause serious bodily injury, death or property damage.**

- Keep grill area clear and free from combustible materials, gasoline and other flammable vapors and liquids.
- Do not obstruct the flow of air for combustion and ventilation.
- Keep the ventilation openings of the tank enclosure cabinet free and clear of debris.
- Visually check burner flames occasionally to ensure proper flame pattern as shown below.

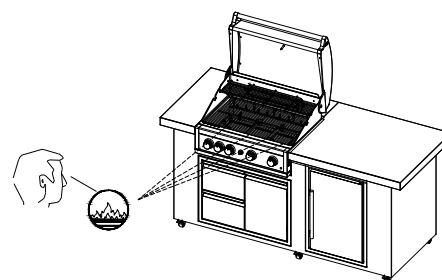

**MAGNIFIED VIEW OF GRILL MAIN BURNER, SEARING BURNER AND SIDE BURNER FLAME THROUGH OPEN LID.**

# Care & Use Instructions

## Manually Lighting Your Grill By Paper Match

To light your gas grill by match, insert a match into the Lighting Stick and follow steps 1 through 5 of the Grill Lighting Instructions. Then, light the match and place Lighting Stick through the Cooking Grids on the grill (See Diagrams Below).

Turn the correlated Control Knob to the  (IGN/HIGH) setting to release gas. The Burner should light immediately.

	<b>CAUTION</b>	
<p><b>Never</b> lean over the grill cooking area while lighting your gas grill. Keep your face and body a safe distance (at least 18 inches) from the front of grill when lighting your grill by match.</p>		

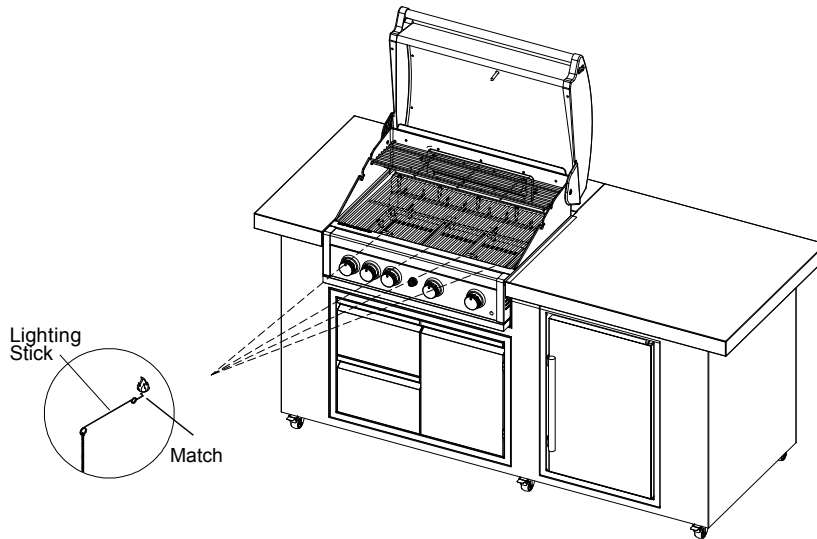

## CORRECT TRANSFORMER AND LIGHT USE

Read all instructions before initial use.

**IMPORTANT:** When using transformer appliances, basic safety precautions should always be used.

The Transformer is set for 120V, 60Hz AC current input, 12VAC, 25W output. The Light is set for 12V, 10W.

Do not let children operate or play nearby your grill or Transformer. Always supervise children and pets if they are in the vicinity of the unit.

### Connecting Transformer

Always attach the assembled Transformer to your grill first and then plug the Cord into a properly grounded outlet, then turn on the Lights.

### Operating Transformer and Light

Do not operate the Transformer if the cord or plug becomes damaged, or if the Transformer or Light malfunctions or have been damaged in any manner.

Do not operate the Transformer if the cord or plug has been damaged in any manner. Do not use the Transformer and Light if cannot be operated safely.

Do not immerse Electrical Cord or Plug in water or expose to rain, as this may result in an electrical shock.

### Disconnect Transformer

Be careful as all surfaces will be hot, both grill, Transformer and the Light. Turn off the Lights and unplug the Transformer from electrical outlet when not in use and before cleaning.

# Care & Use Instructions

## CORRECT ROTISSERIE USE

- 1. Read all instructions before initial use.**

IMPORTANT: When using electrical appliances, basic safety precautions should always be used.  
The Rotisserie Motor is set for 120V, 60Hz AC current.  
The Rotisserie is for outdoor use only.  
Never allow children to operate your grill or rotisserie.  
Do not allow children or pets to play near your grill.  
Always supervise children and pets if they are in the vicinity of the unit.  
Rotisserie can cook a maximum of 8-10 pounds of food at one time.
- 2. Connecting Rotisserie**

Always attach the assembled Rotisserie to your grill first and then plug the Cord into an outlet.
- 3. Operating Rotisserie**



Do not operate the Rotisserie if the cord or plug becomes damaged, or if the Rotisserie malfunctions or has been damaged in any manner.  
The use of accessory attachments is may cause injuries.  
Do not use this Rotis-serie for any purposes other than its intended use.  
Do not immerse Electrical Cord, Plug or Motor in water or expose to rain, as this may result in an electrical shock.
- 4. Disconnect Rotisserie**

Use caution as all surfaces will be hot, both grill and Rotisserie. Use protective mitts to handle the Rotisserie. Unplug the Rotisserie from electrical outlet when not in use and before cleaning. Allow to cool before adding or removing parts.  
When Rotisserie cooking place a Cooking Pan under the food to be cooked as this will capture the drippings and keep your grill clean of excess grease which could cause a fire.  
CAUTION: Use caution when moving a Cooking Pan containing hot oils.  
Should a grease fire occur, turn the burners and gas off and leave the grill lid closed until the fire is out.
- 5. Store the Rotisserie indoors**

When Rotisserie is not in use, store it indoors in a dry place.

 **CAUTION** 



To protect against shock hazard risk, connect only to properly Grounded Outlet.

 **CAUTION** 

California Proposition 65  
The electrical supply cord and plug of the rotisserie contain chemicals, including lead, known to the State of California to cause cancer, and birth defects or other reproductive harm. Wash hands after handling.

## ELECTRICAL EQUIPMENT USE

1. To protect against electric shock, do not immerse cord or plugs in water or other liquid.
2. Unplug from the outlet when not in use and before cleaning. Allow grill to cool before putting on or taking off parts.
3. Do not operate any outdoor cooking gas appliance with a damaged cord, plug, or after the appliance malfunctions or has been damaged in any manner. Contact the Grand Hall for repair.
4. Do not let the cord hang over the edge of a table or touch hot surfaces.
5. Do not use the appliance for any purposes other than its intended use. Do not alter this appliance in any way.
6. When connecting, first connect plug to the outdoor cooking gas appliance then plug appliance into the outlet.
7. Use only a Ground Fault Interrupter (GFI) protected circuit with this outdoor cooking gas appliance.
8. Never remove the grounding plug or use with an adapter of 2 prongs.
9. Use only extension cords with a 3 prong grounding plug, rated for the power of the equipment, and approved for outdoor use with a W-A marking.

 **CAUTION** 

To protect against electrical shock, do not immerse electrical cord, plugs or motor in water or expose to rain. Protect electrical elements from burners, hot grill surfaces and grease.

 **CAUTION** 

Keep any electrical supply cord and the fuel supply hose away from any heated surface.

# Care & Use Instructions

## Cleaning the burner tubes and burner ports.

To reduce the chance of **FLASHBACK FIRE** you must clean the Burner Tubes as follows at least once a month in summer and fall or whenever spiders are active in your area, and if your grill has not been used for an extended period of time.

1. Turn all Burner Valves to the full OFF position.
2. Turn the LP Gas tank valve to the full OFF position.
3. Detach the LP Gas regulator assembly from your gas tank.
4. Remove the Cooking Grids, Cooking Rack/Secondary, Flame Tamer and Grease Tray from your grill.
5. Remove the screws from the rear of each Main and Searing Burner using a Phillips Head Screwdriver.
6. Carefully lift each Burner up and away from the Gas Valve Orifice.
7. Check and clean burner/venturi tubes for insects and insect nests. A clogged tube can lead to a fire beneath the grill.
8. Refer to **Figure 1** and perform one of these three cleaning methods:

- METHOD 1:** Bend a stiff wire or wire coat hanger into a small hook as shown and run the hook through the Burner Tube and inside the Burner several times to remove debris.

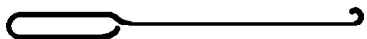

- METHOD 2:** Use a bottle brush with a flexible handle and run the brush through the Burner Tube and inside the Burner several times to remove any debris.
- METHOD 3:** Use an air hose to force air through each Burner Tube. The forced air should pass debris or obstructions through the Burner and out the Ports.

**Figure 1**

TO CLEAN BURNER TUBE, INSERT HOOK AS INDICATED BY THE ARROW

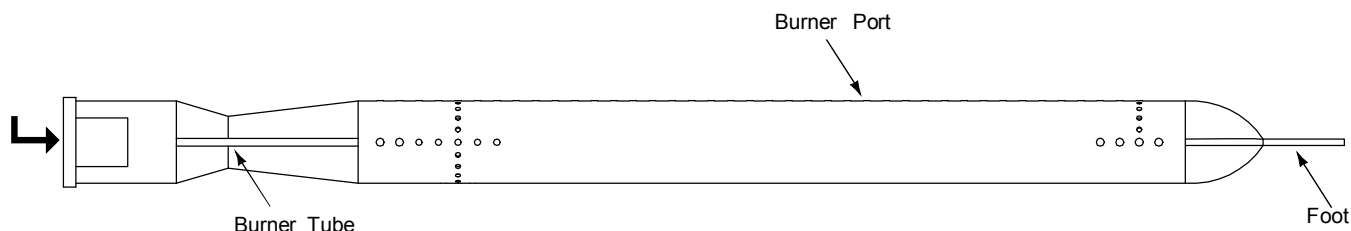

Regardless of which Burner cleaning procedure you use, we recommend that you also complete the following cleaning regimens to help prolong Burner life.

- After each use of the main grill or searing cooking zone it is necessary to burn off food particles and drippings which can clog Burner ports and reduce Burner performance. OPEN the grill Lid, ignite the burner(s) and operate grill on **IGN/HIGH** setting for 10 to 15 minutes.
- Use a nylon brush, blower or vacuum to remove accumulated ash from the outer surface of each Burner. Clogged tube style Burner ports can be cleaned with a stiff wire, such as an open paper clip. **DO NOT** use a stiff brush or sharp tool of any type on the searing burner.
- Inspect each Burner for damage (cracks or holes) and if such damage is found, order and install a new Burner. After installation, check to ensure that the Gas Valve Orifices are correctly placed inside the ends of the Burner Tubes. Also check the position of your Spark Electrode.

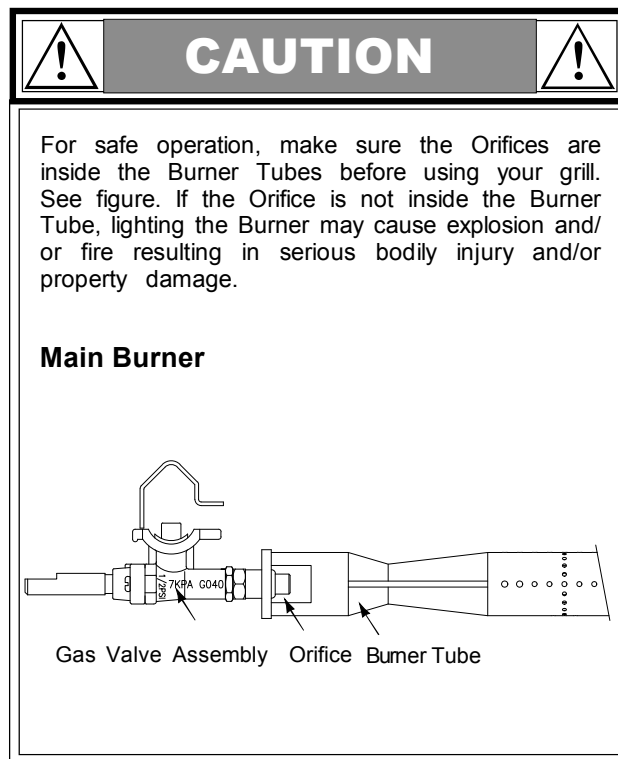

# Storage Instructions

## Storage Instructions

<p>Item BS04-BI-LP BS04R-BI-LP BS04RCIS-LP-D BS04RFIS-LP-B</p>	<ol style="list-style-type: none"><li>1. Shut off the gas at the tank.</li><li>2. Disconnect the tank and store it in an upright position in an outdoor space away from dryer and furnace vents and play areas.</li><li>3. Coat the burners and other metal parts with cooking oil to repel moisture that can build up over the winter and to prevent rust.</li><li>4. Make sure to put on the grill cover when the grill is in a cool condition. NEVER put on the grill cover when the grill is still hot.</li><li>5. Clean the grill, and keep the grill out of moisture and cooking residue on the stainless surface before put on the grill cover to prevent your grill from getting rust. (NEVER put on the grill cover when the grill is still wet.)</li></ol>
--	--

## SPECIFICATIONS

Models/Finish	BS04R-BI-LP/ BS04-BI-LP
Main Burners	4x10,000 BTU/HR
Rotisserie Burner	12,000 BTU/HR
Dimensions (L × W × H)	30.2 × 25×20.01 in. (BS04-BI-LP)
	78.3× 33.17 ×47.92 in. (BS04R-BI-LP/ BS04RFIS-LP-B)
Warranty	1-year limited

Models/Finish	<b>BS04RCIS-LP-D</b>
Main Burners	4x10,000 BTU/HR
Rotisserie Burner	12,000 BTU/HR
Dimensions (L × W × H)	60.5× 26.95 ×47.92 in.
Warranty	1-year limited

# Warranty Information

Should you encounter any problem,  
Please contact us first.  
DON'T Return the product to the store.  
We can help.

For assistance, contact customer service at [support@1800acs.com](mailto:support@1800acs.com); [prokansupport@1800acs.com](mailto:prokansupport@1800acs.com) or call 1-877-419-2598 Monday through Friday from 8:00 a.m. to 8:00 p.m. EST.

Please note that the limited warranty is given to and covers the Original purchaser only and such coverage is not transferable. The proof of purchase may be required when warranty service is occurred.

The limited warranty is limited to replacement of parts, at the manufacturer's option that proved to be defective from manufacturing failure with the manufacturer's examination. The warranty doesn't cover any failures or operating difficulties due to accident, abuse, misuse, alternation or modification, misapplication, vandalism, improper installation, maintenance or service, damages caused by flashback fires or grease fire, as set out in this operation manual. Deterioration or damage due to severe weather conditions such as fail, hurricane, earthquakes, tsunami, tornadoes, Acts of God or terrorism, discoloration due to exposure to chemicals either directly or in the atmosphere, is not covered by this limited warranty.

How to order replacement parts:

Please refer to the parts list on this instruction manual. To make sure you obtain the replacement parts for your grill, the following information is required to assure the correct parts.

For parts and service, please provide the following information:

- Name
- Serial Number
- Parts number/ description of parts needed
- Shipping address
- Phone number
- Pictures of the overall product
- Pictures of the part or issue
- Proof of Date of purchase and/or picture of receipt

## Warranty Restrictions

- This warranty is non-transferable.
- This warranty is void if grill is used for commercial or rental purposes.
- This grill is safety certified for use only in the county where purchased, Modification for use in any other location is a safety hazard and will void the warranty.

## Contact Information:

Manufacturer: Zhuhai Prokan Relaxation  
Equipment Co., LTD  
Address: Ningtang INDUSTRIAL AREA OF  
Tangjiawan TOWN, ZHUHAI, GUANGDONG,  
CHINA  
[www.prokangrills.com](http://www.prokangrills.com)