

# Installation & Assembly

Version:1.0

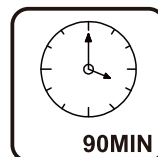

**EN\_IMPORTANT, RETAIN FOR FUTURE REFERENCE: READ CAREFULLY.**

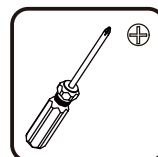
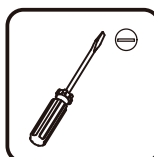
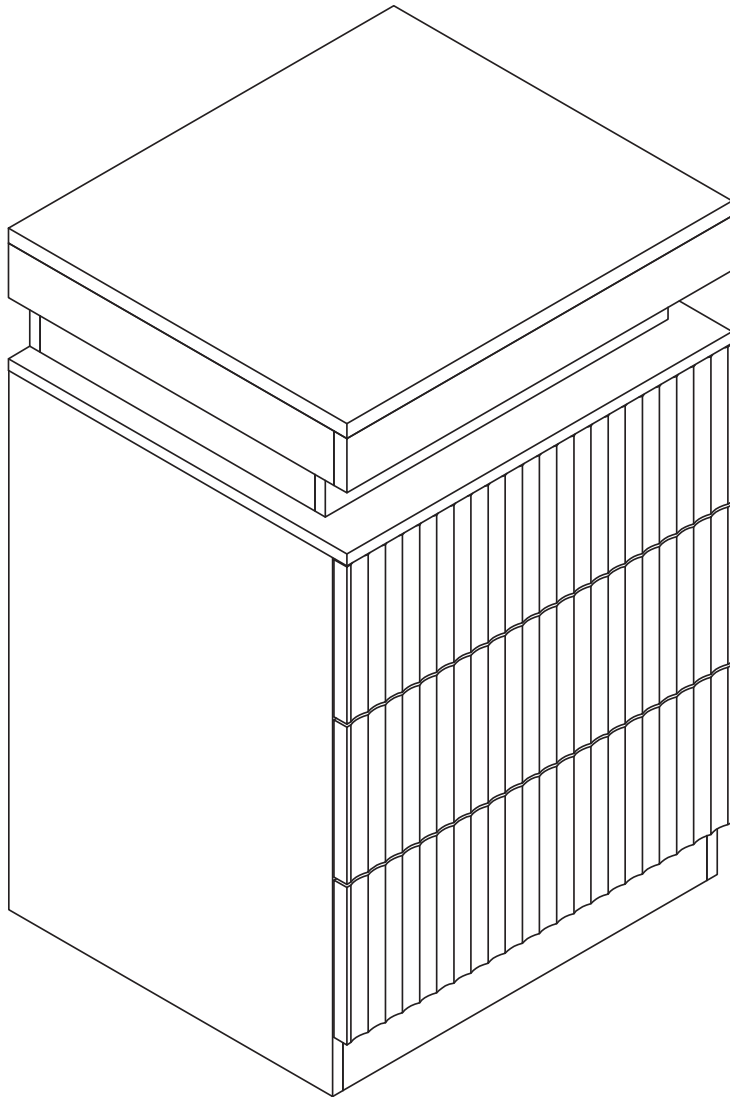
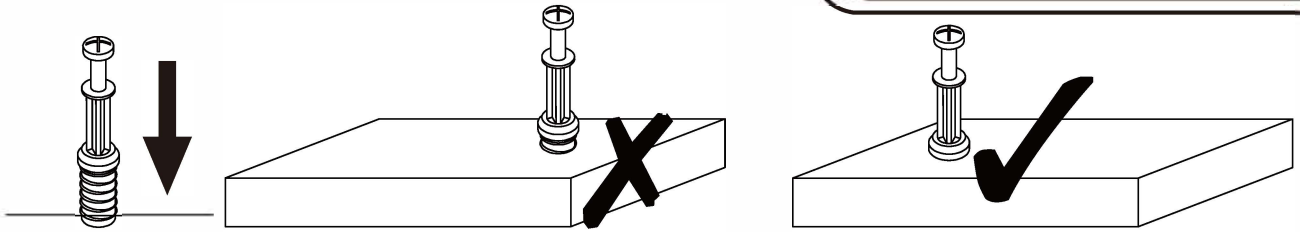

**EN\_QUICKFIT:** Tighten quickfit until shoulder is flush with panel. Do not overtighten or undertighten.

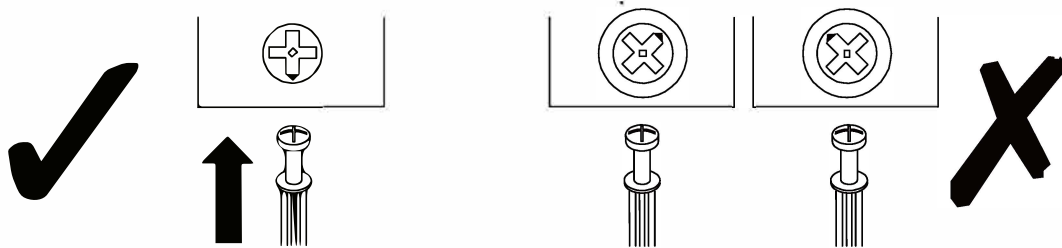

**EN\_CAM LOCK:** When fitting cam lock, ensure starting position is correct before you insert connecting quickfit.

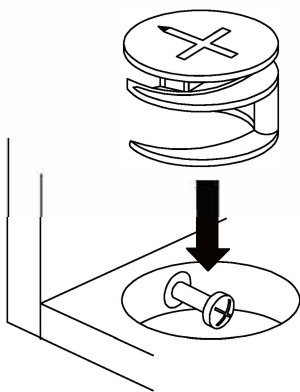

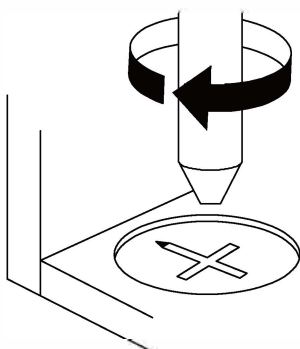

**EN\_Quickfit** head should be in the centre of the cam lock when the two panels are joined.  
Cam lock should be inserted before quickfit.



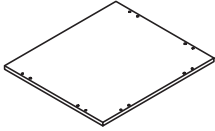
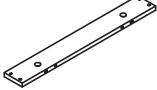
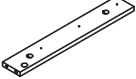
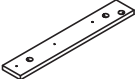
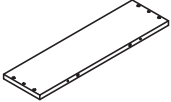
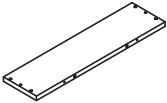
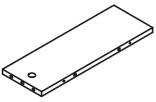
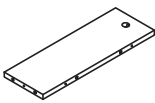
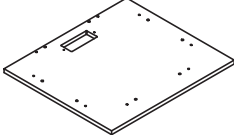
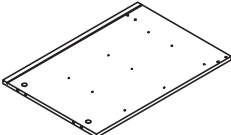
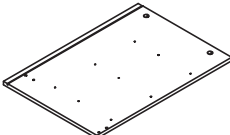

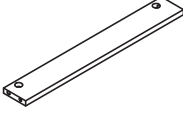
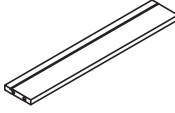
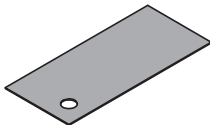
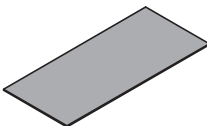
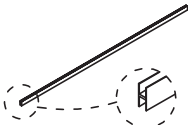
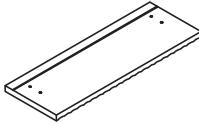
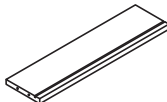
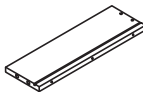
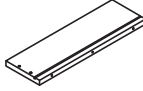
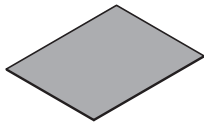



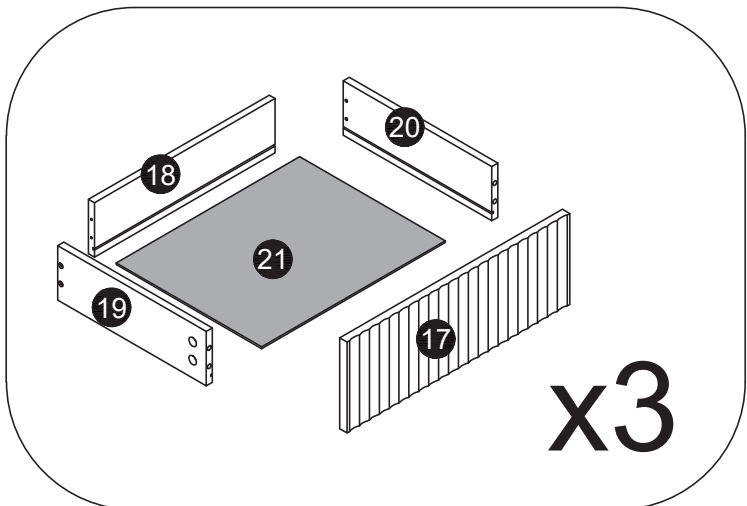
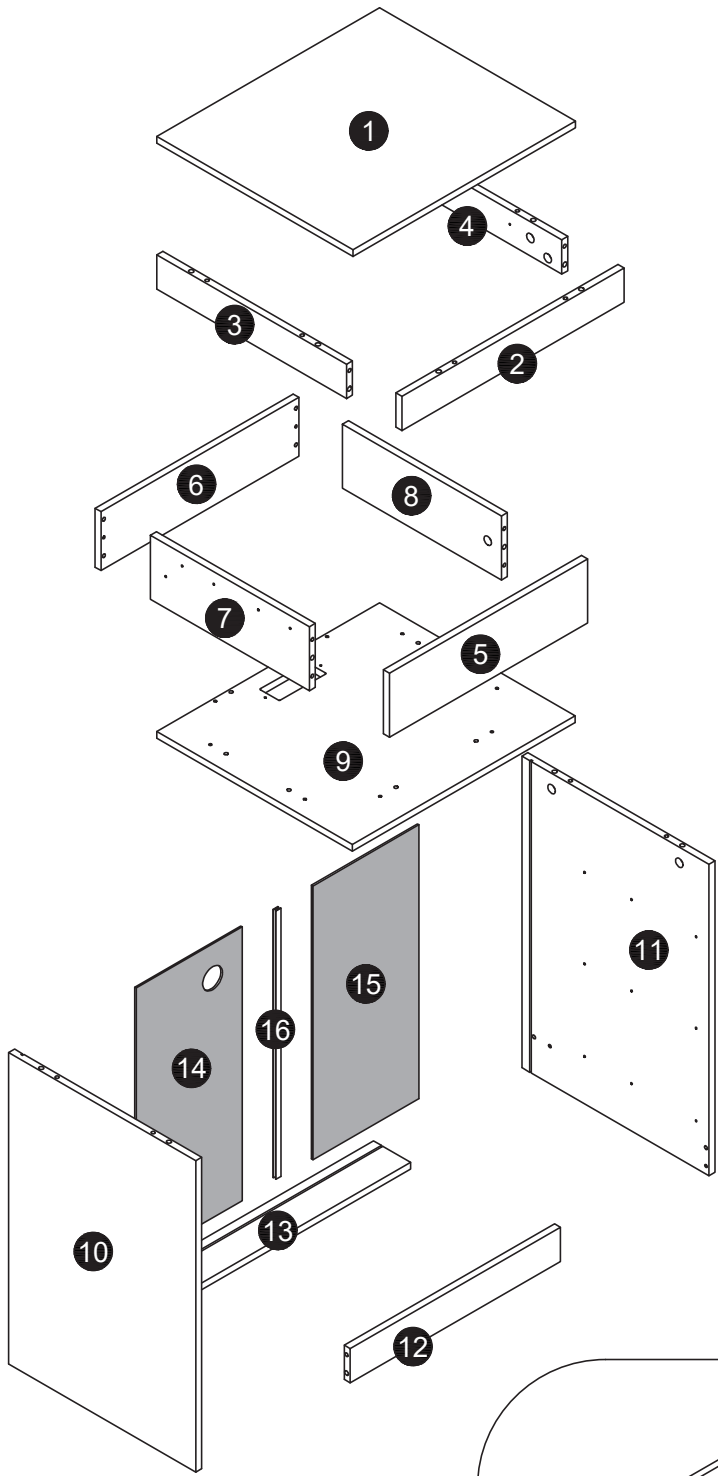









**EN\_Turn** cam lock clockwise to tighten.

NO.	PARTS	QTY	SPARE
①		x1	
②		x1	
③		x1	
④		x1	
⑤		x1	
⑥		x1	
⑦		x1	
⑧		x1	
⑨		x1	
⑩		x1	
⑪		x1	

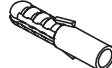
NO.	PARTS	QTY	SPARE
⑫		x1	
⑬		x1	
⑭		x1	
⑮		x1	
⑯		x1	
⑰		x3	
⑱		x3	
⑲		x3	
⑳		x3	
㉑		x3	
	 Hardware Kit	x1	

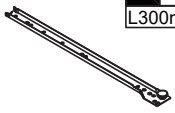
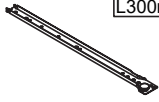
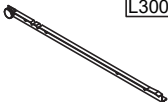
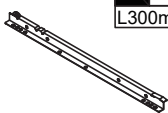

 <p><b>A</b> x30 Ø6x35mm +3(spare)</p>	 <p><b>B</b> x30 Ø15x10mm +3(spare)</p>	 <p><b>C</b> x32 Ø6x30mm +3(spare)</p>	 <p><b>D</b> x23 Ø4x35mm +2(spare)</p>	 <p><b>E</b> x50 Ø3.5x12mm +5(spare)</p>	 <p><b>F</b> x1</p>
 <p><b>G</b> x2 Ø3.5x12mm</p>	  <p><b>H</b> x1 Ø4x10mm</p> <p>H-1 H-2</p>	 <p><b>I</b> x1</p>	 <p><b>J</b> x1</p>	  <p><b>K</b> x1 Ø4x14mm</p> <p>K-1 K-2</p>	 <p><b>L</b> x1</p>
  <p><b>M</b> x4 Ø3x16mm +1(spare)</p> <p>M-1 M-2</p>	 <p><b>N</b> x2</p>				
 <p><b>CL</b> x3 L300mm</p>	 <p><b>CR</b> x3 L300mm</p>	 <p><b>DL</b> x3 L300mm</p>	 <p><b>DR</b> x3 L300mm</p>		

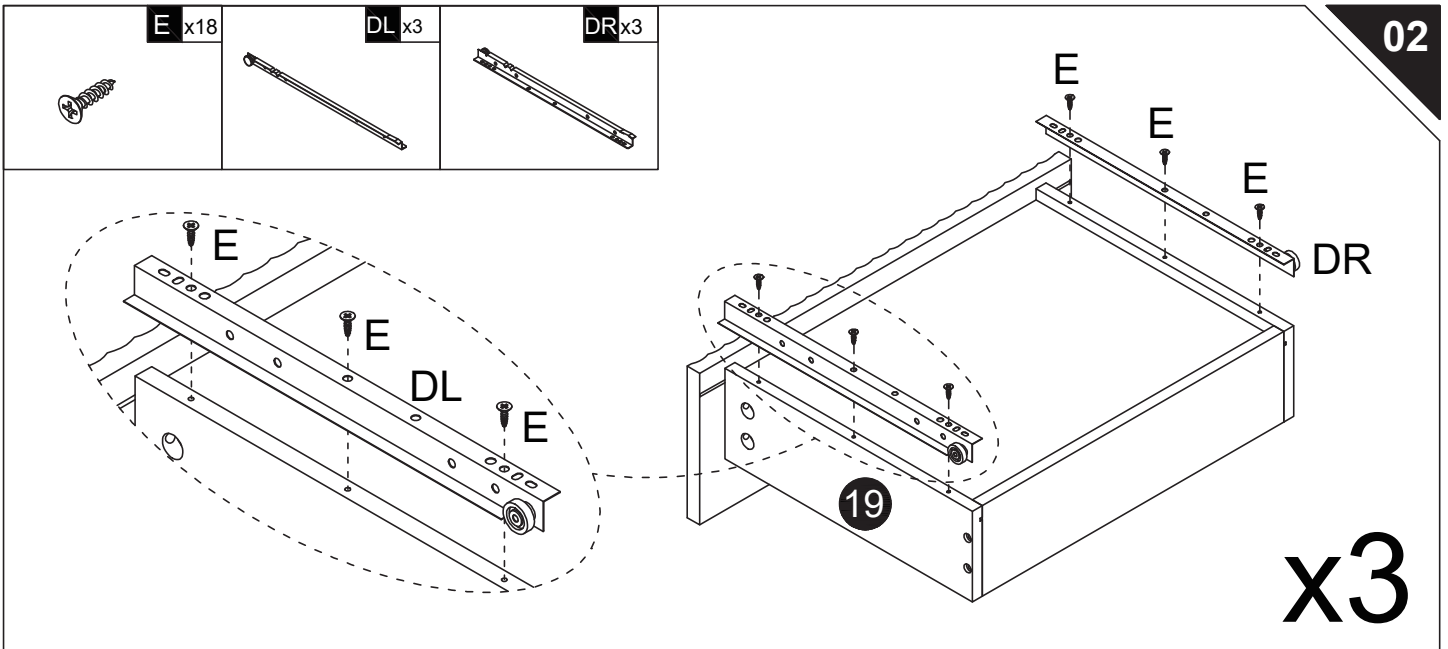
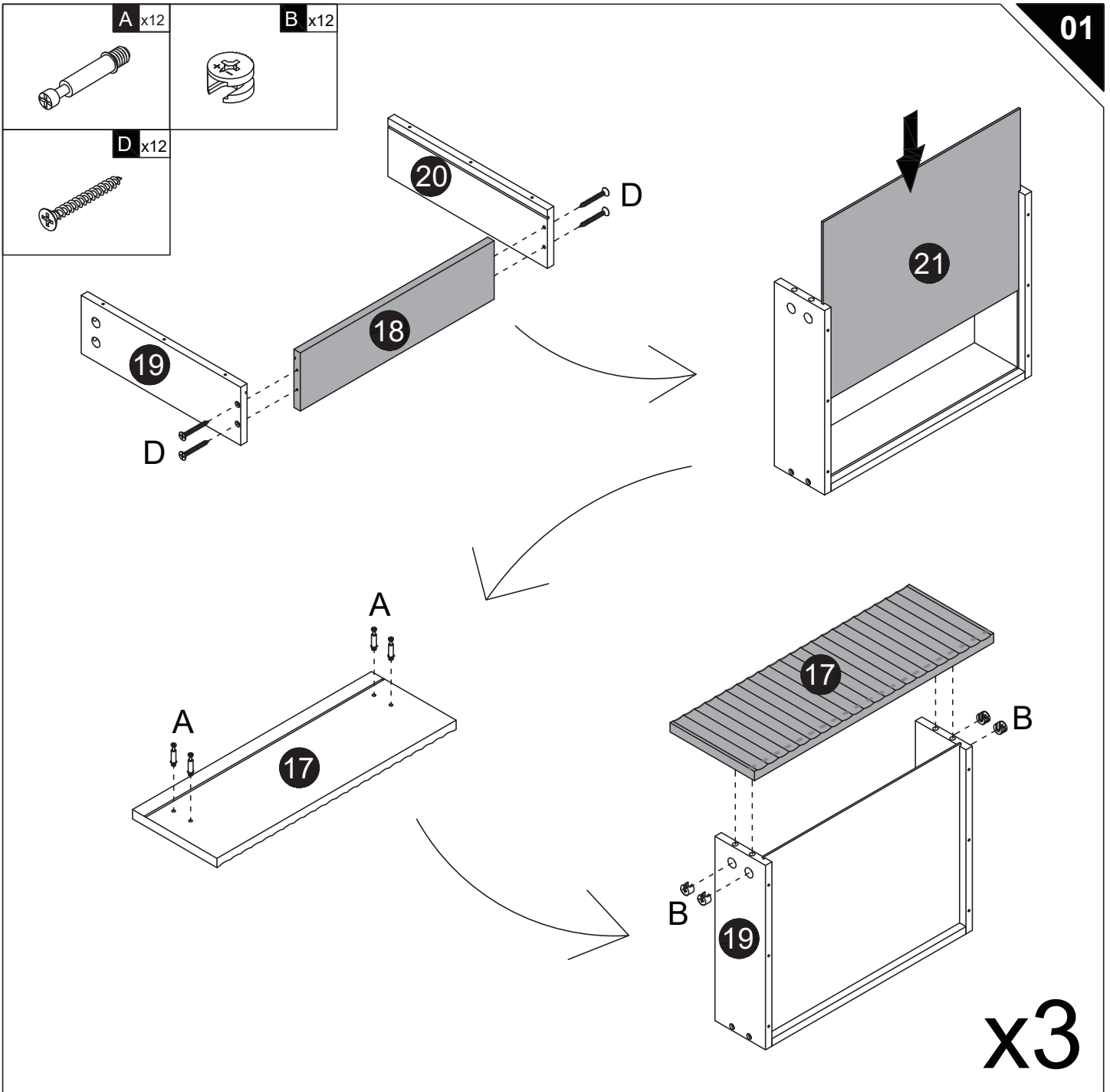

E x18

CL x3

CR x3

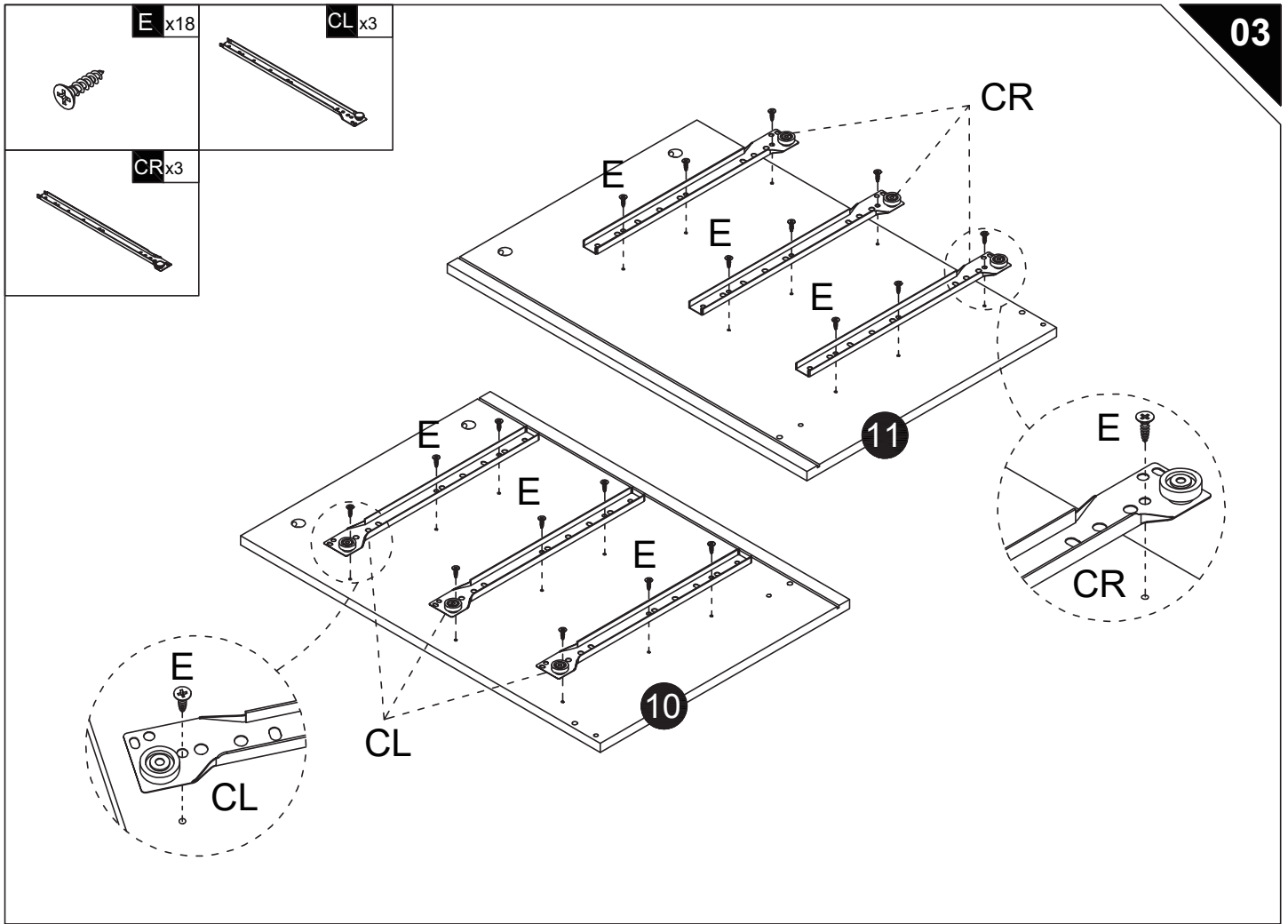

A x4

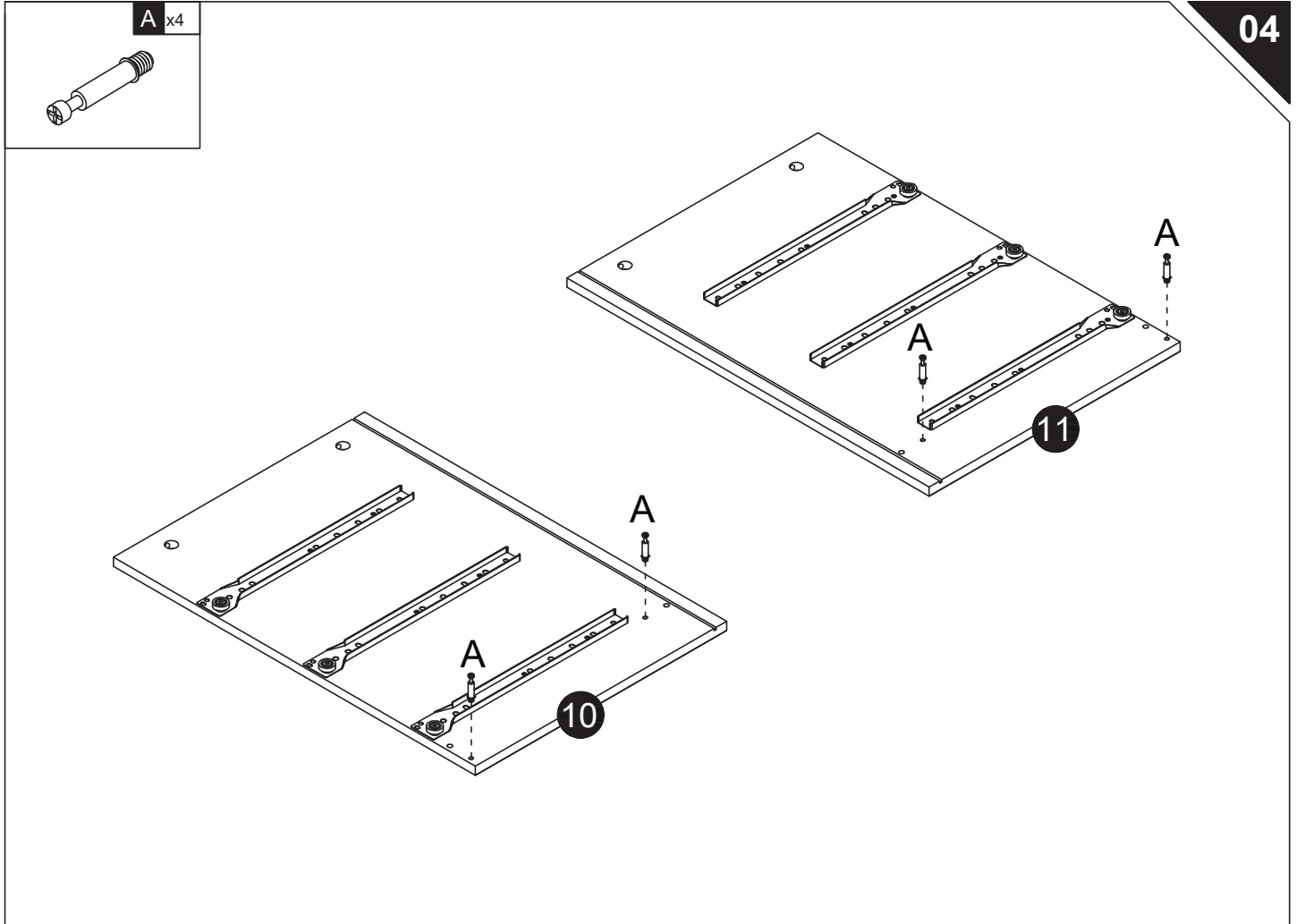

B x2

C x2

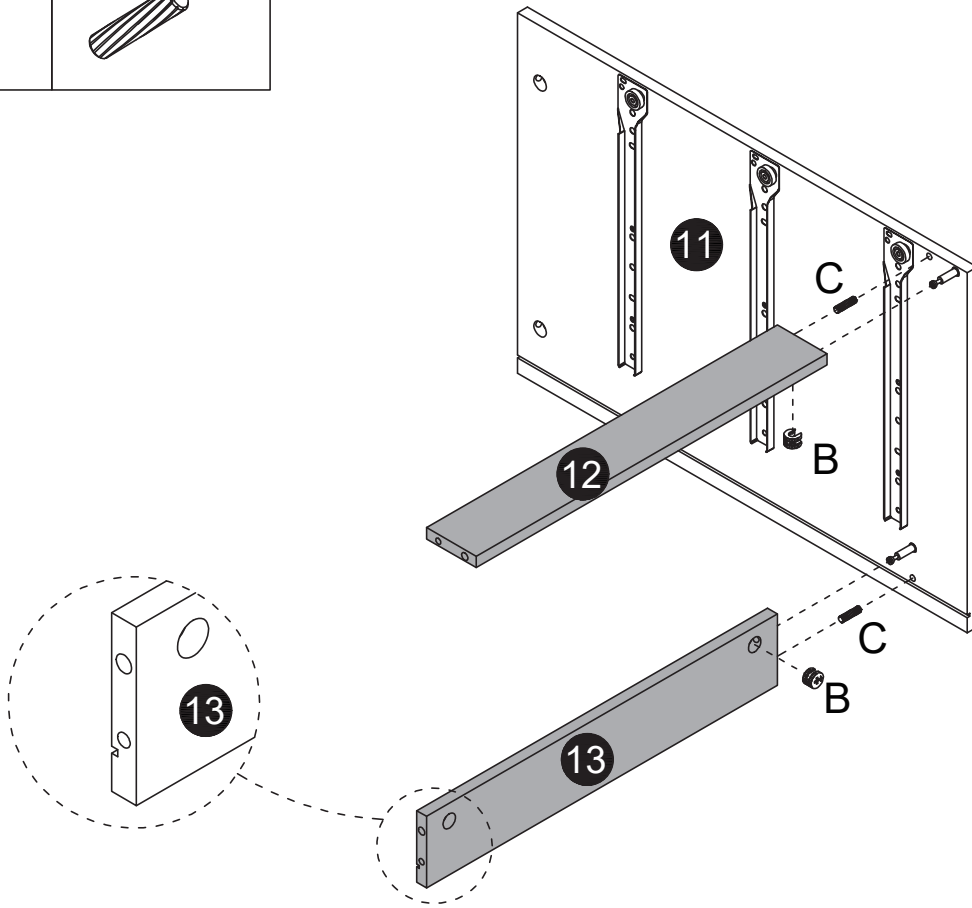

B x2

C x2

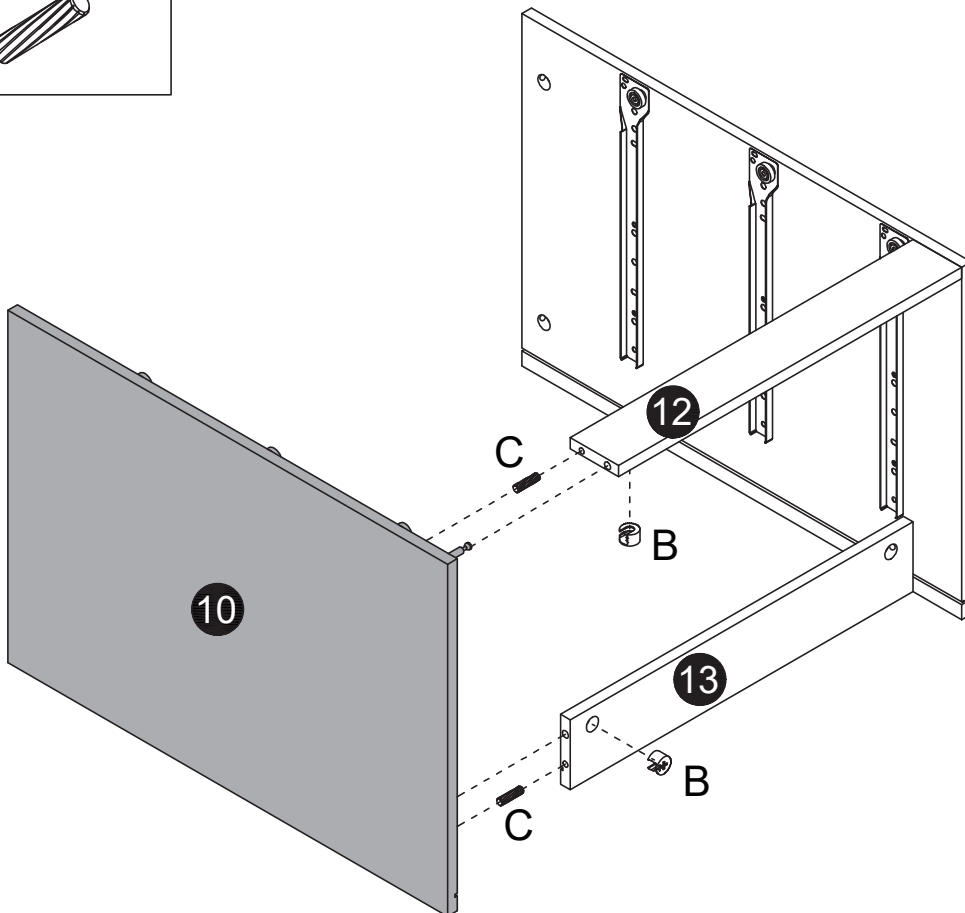

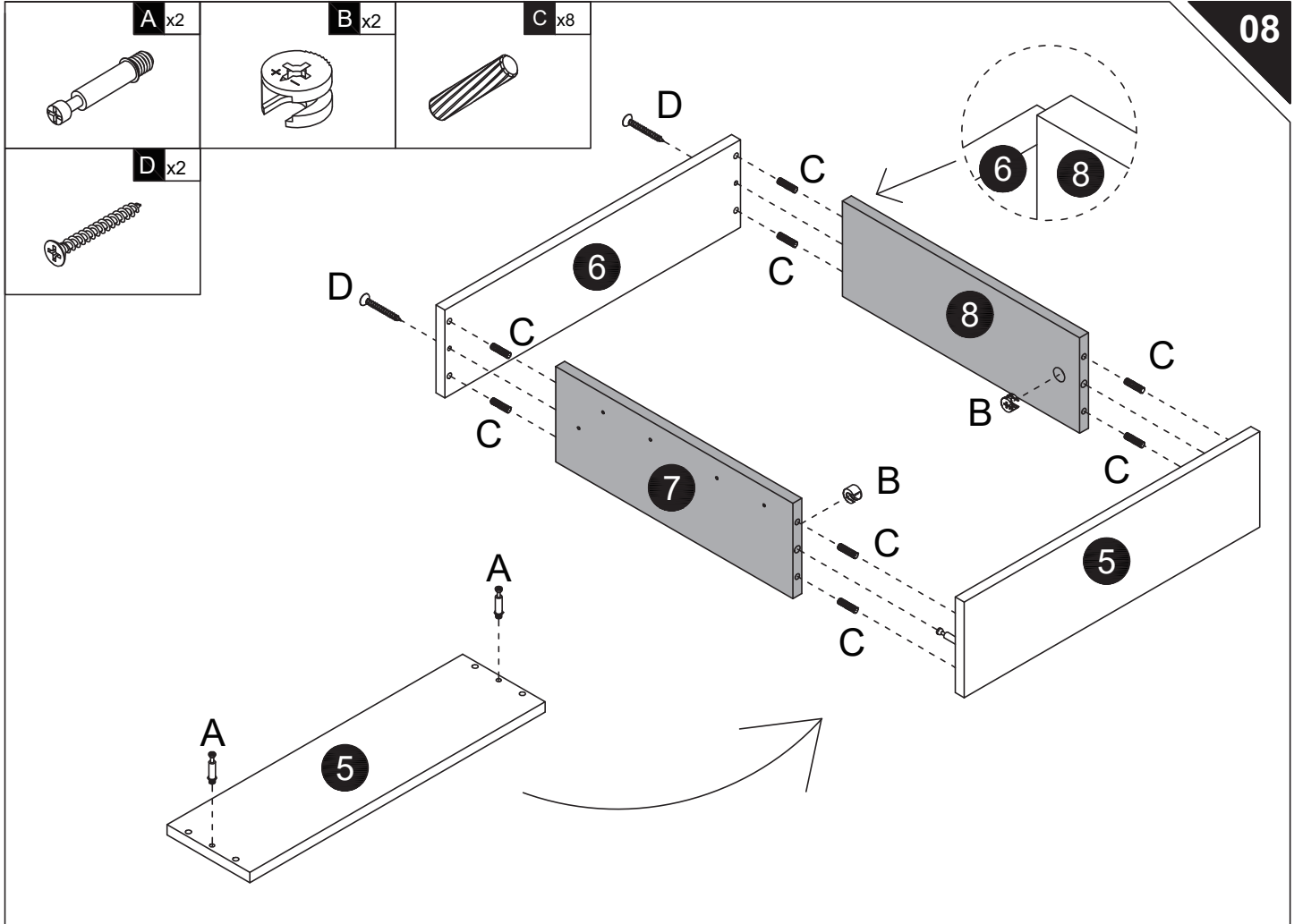
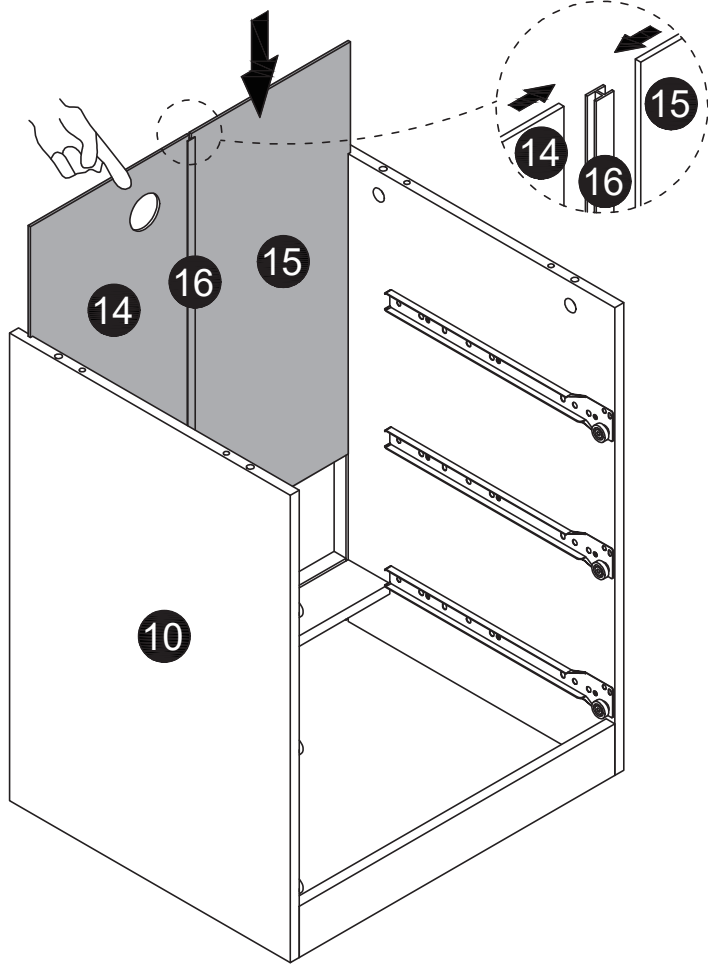

C x8

D x8

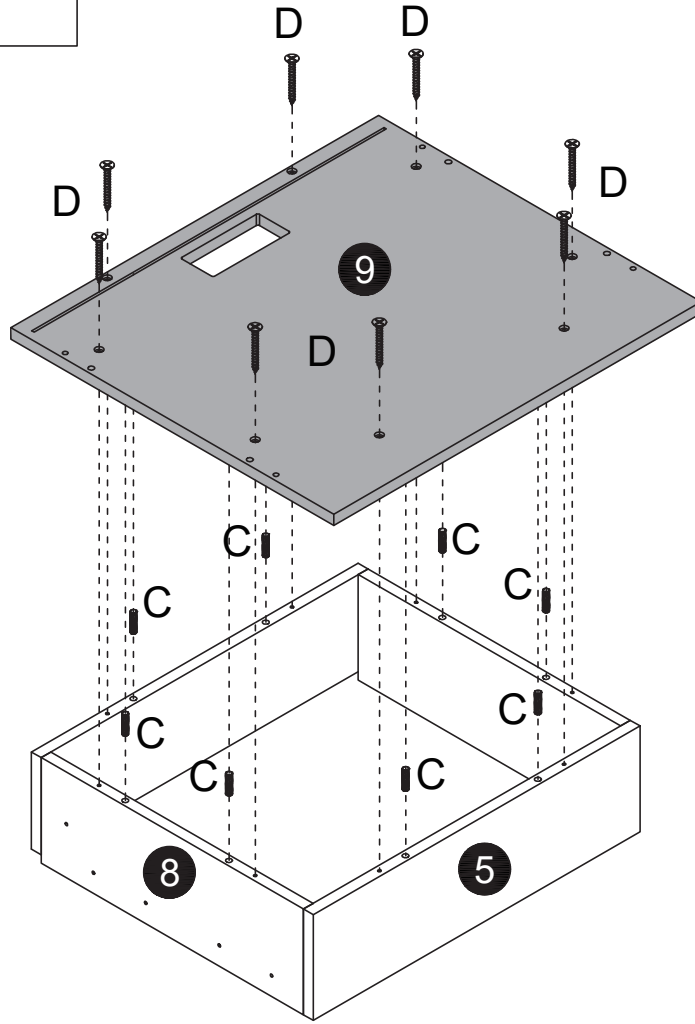

A x4

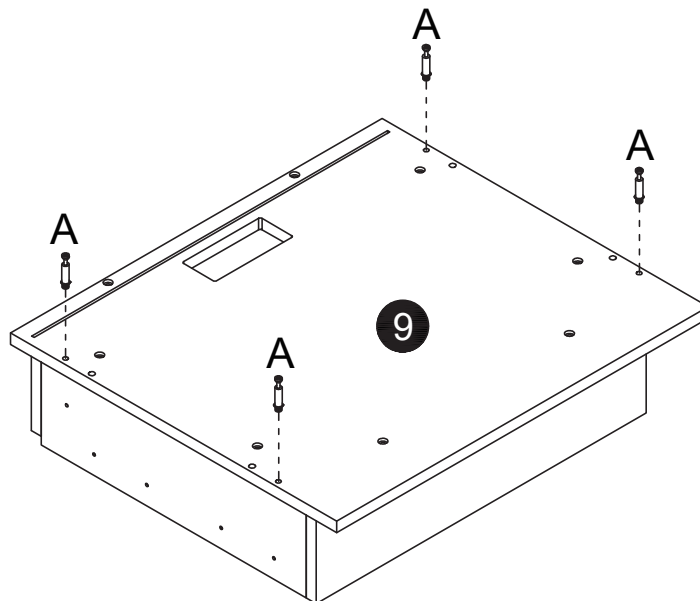
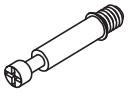

B x4

C x4

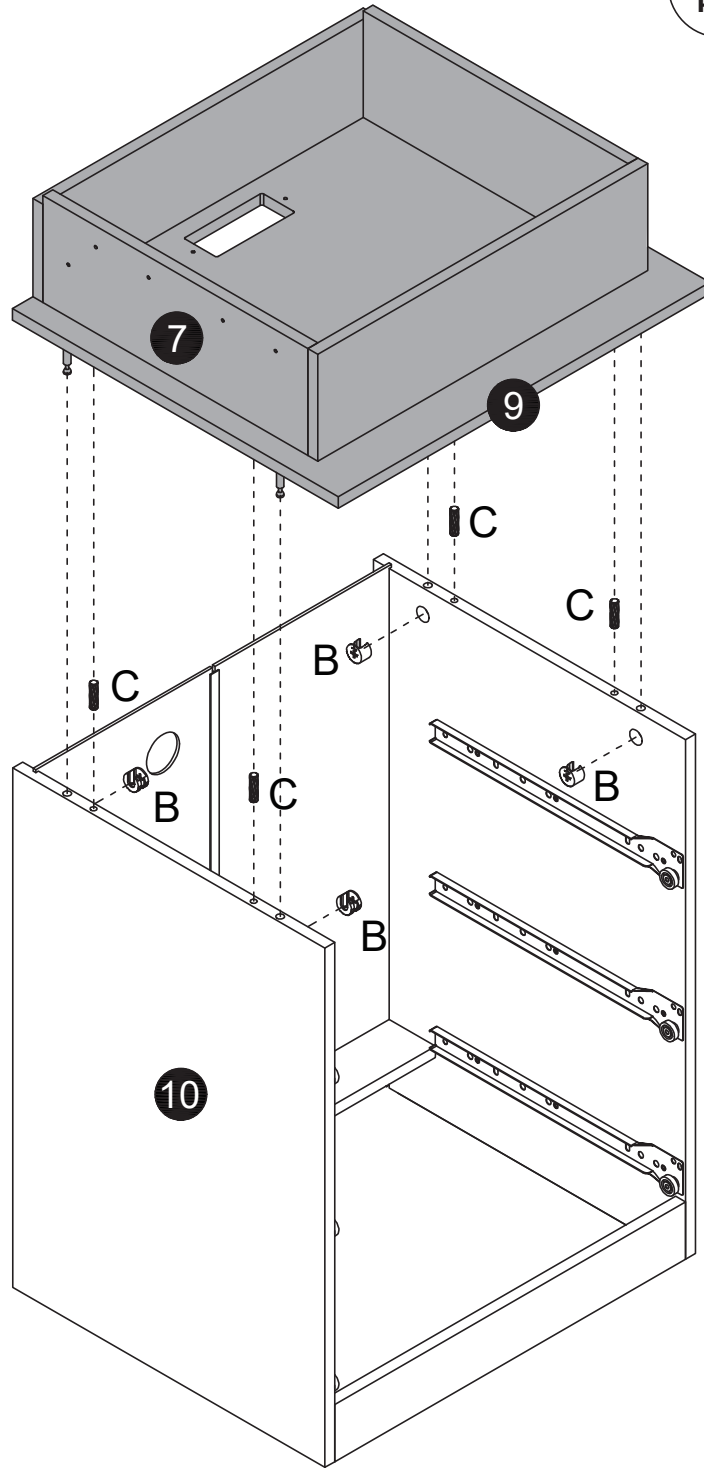
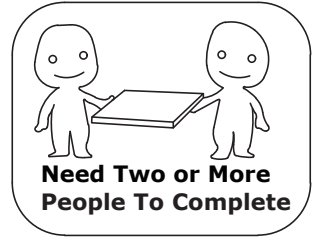

F x1

G x2

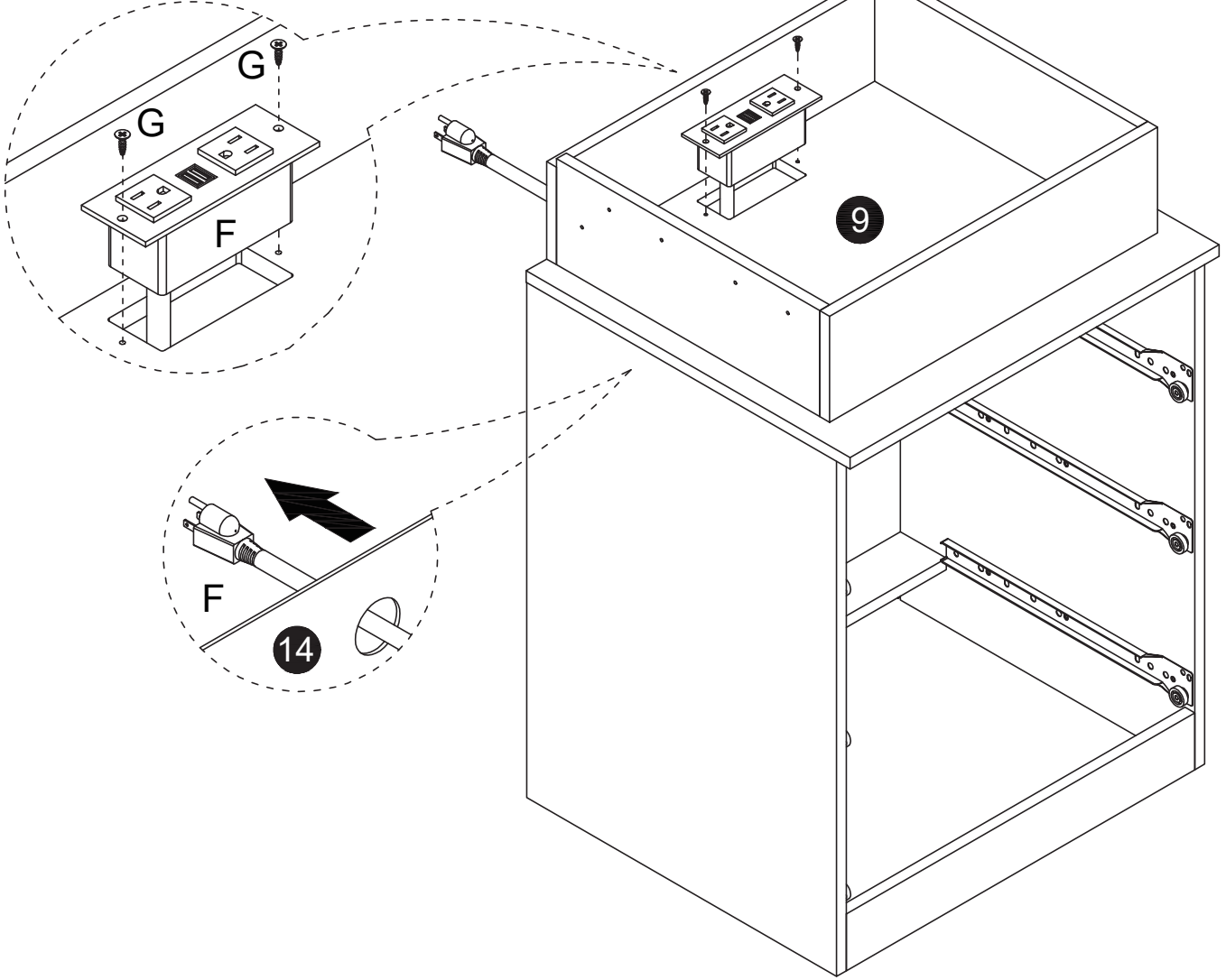
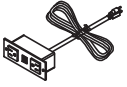

N x2

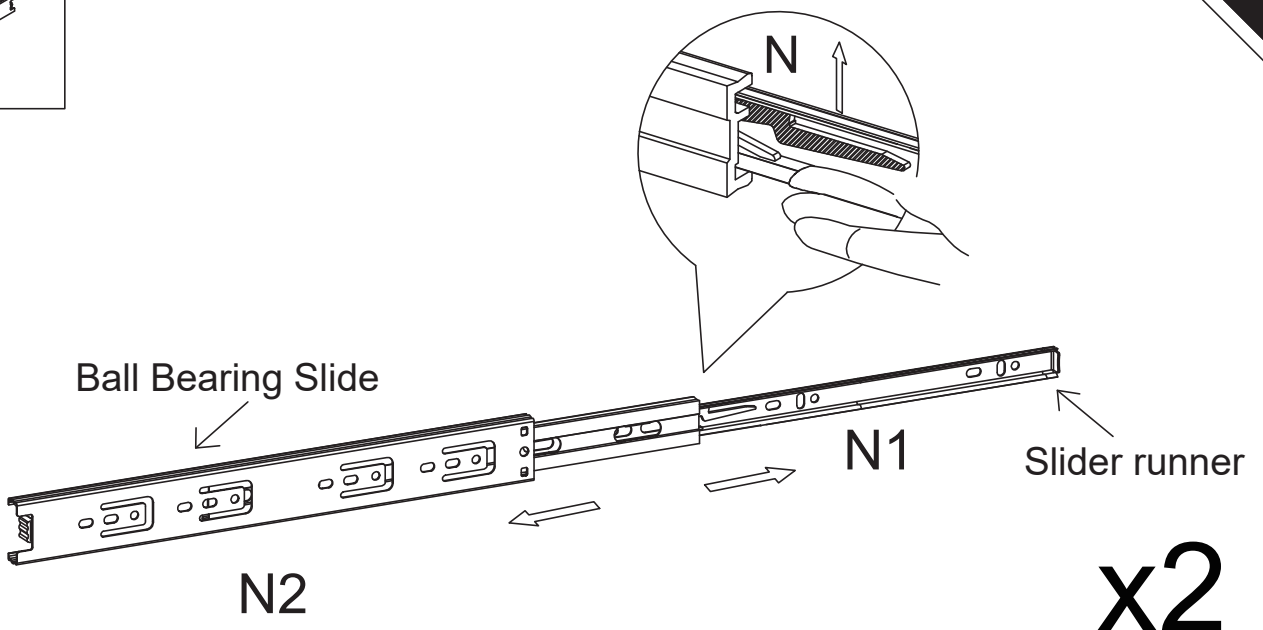
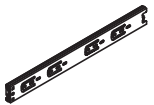

E x8

N2 x2

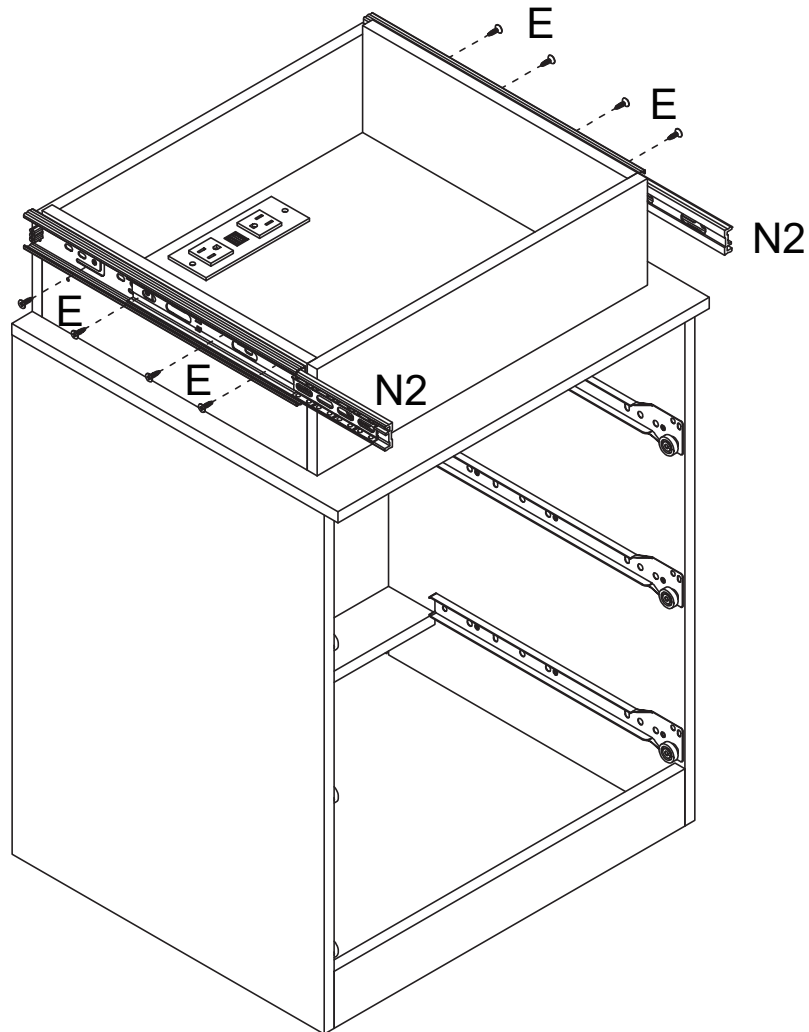
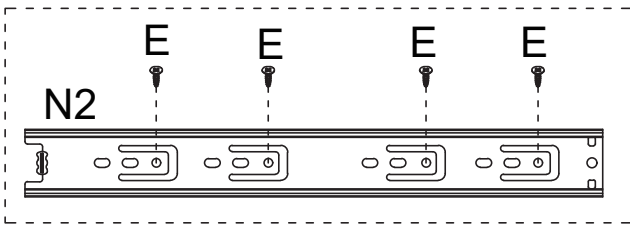
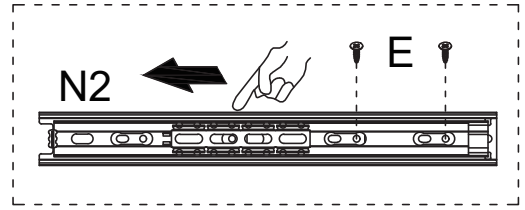
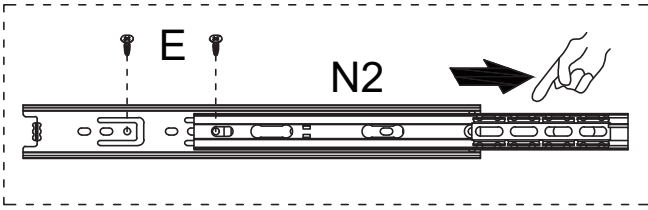

H x1

J x1



H-1

H-2

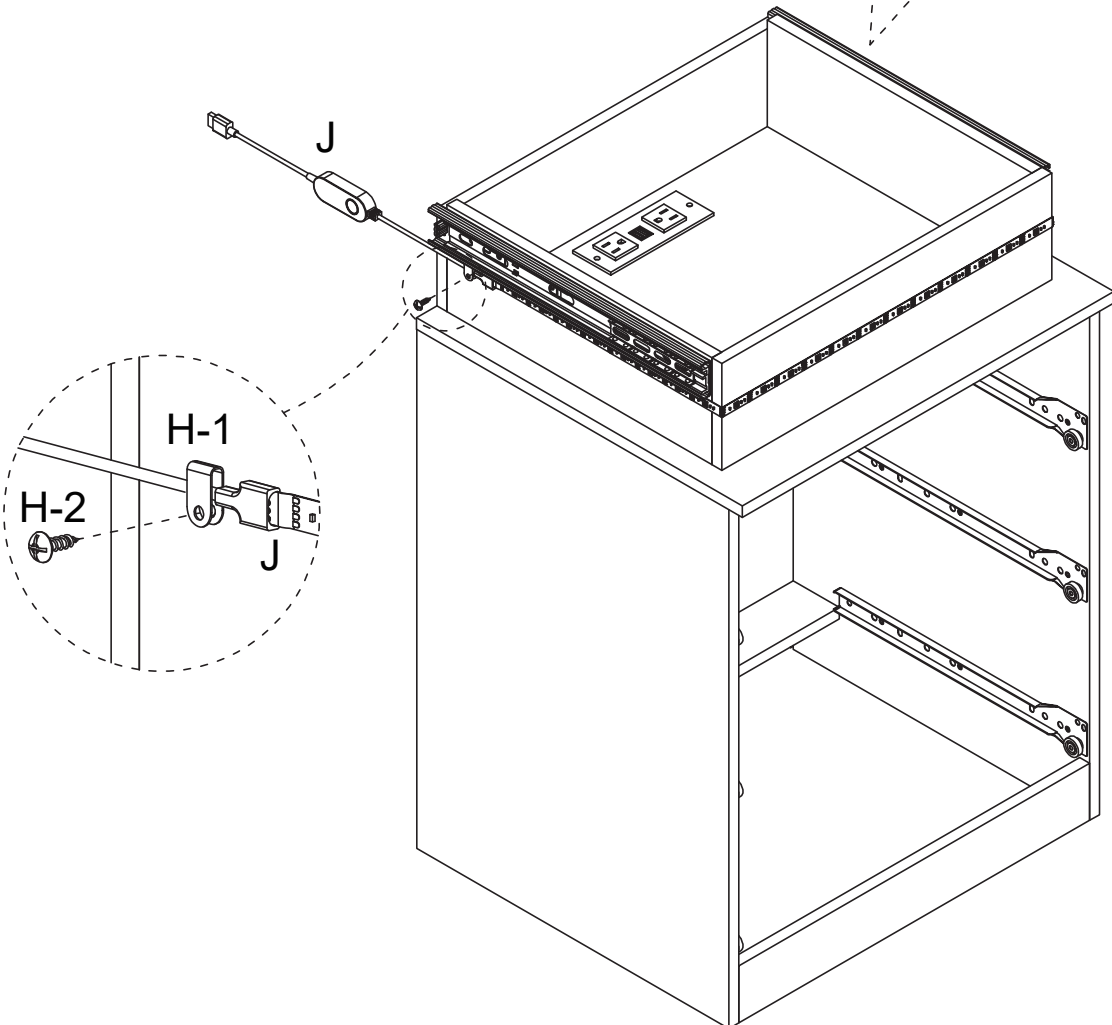
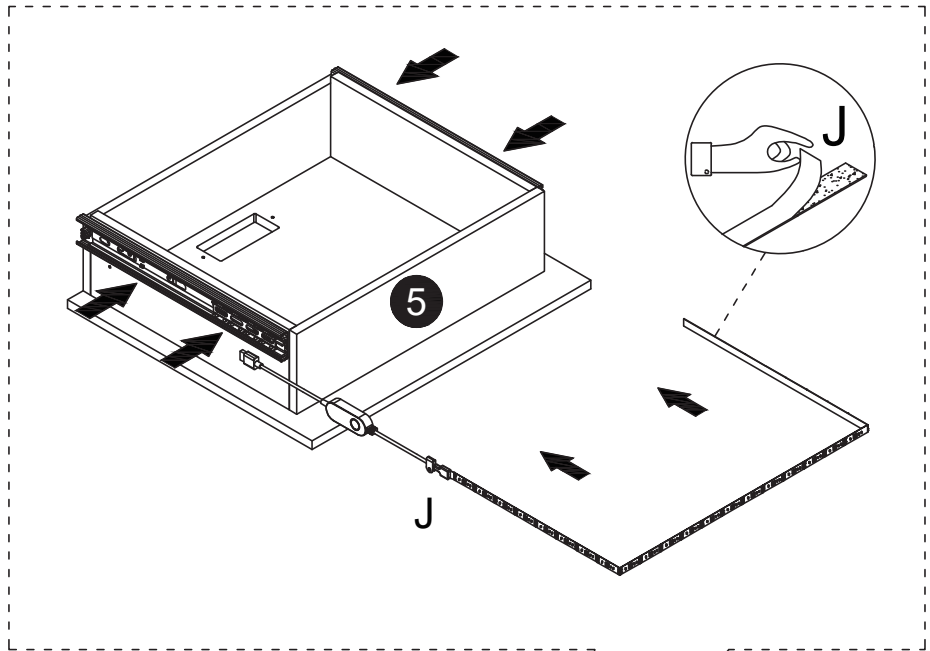
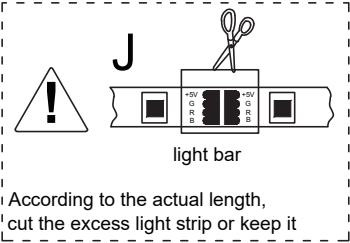

I x1

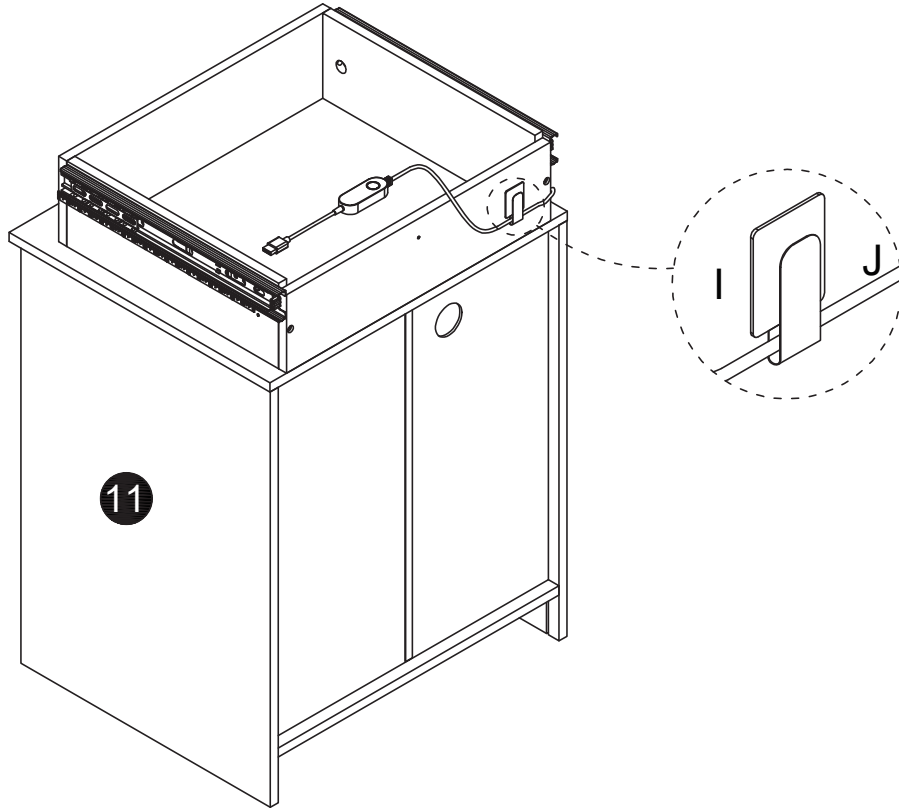

A x8

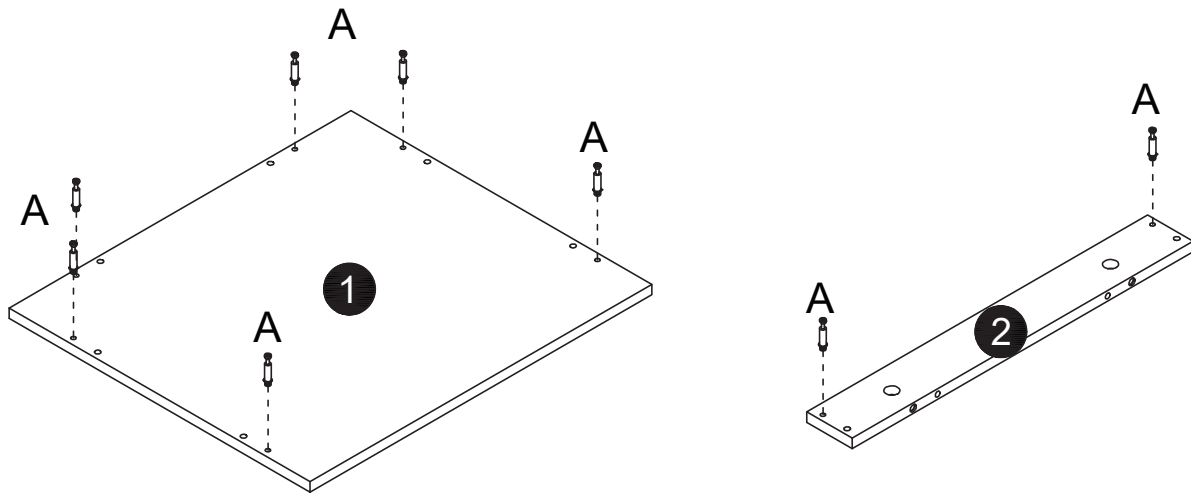
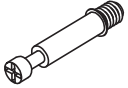

B x2

C x2

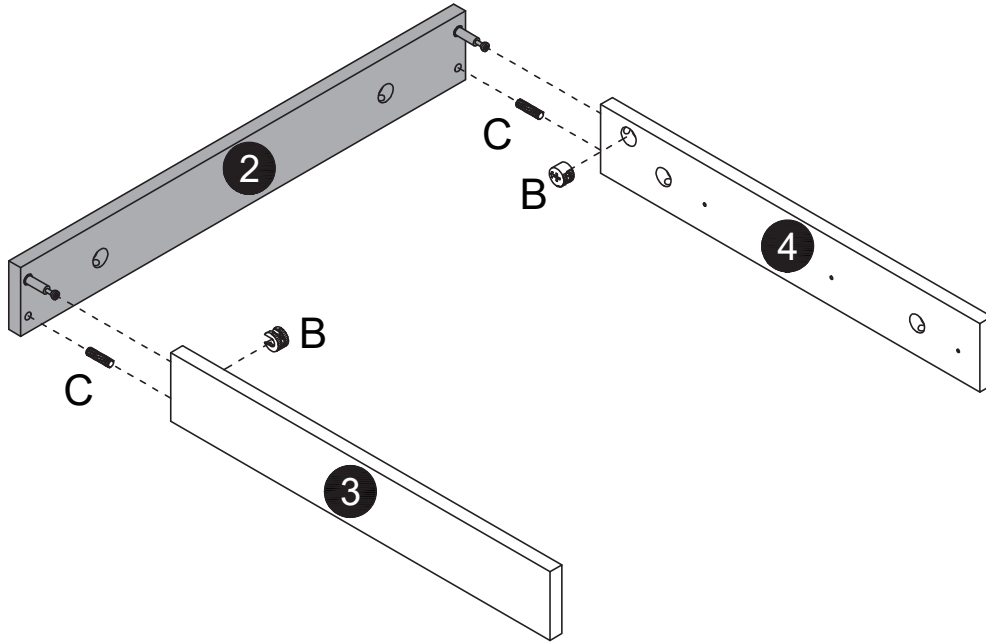

B x6

C x6

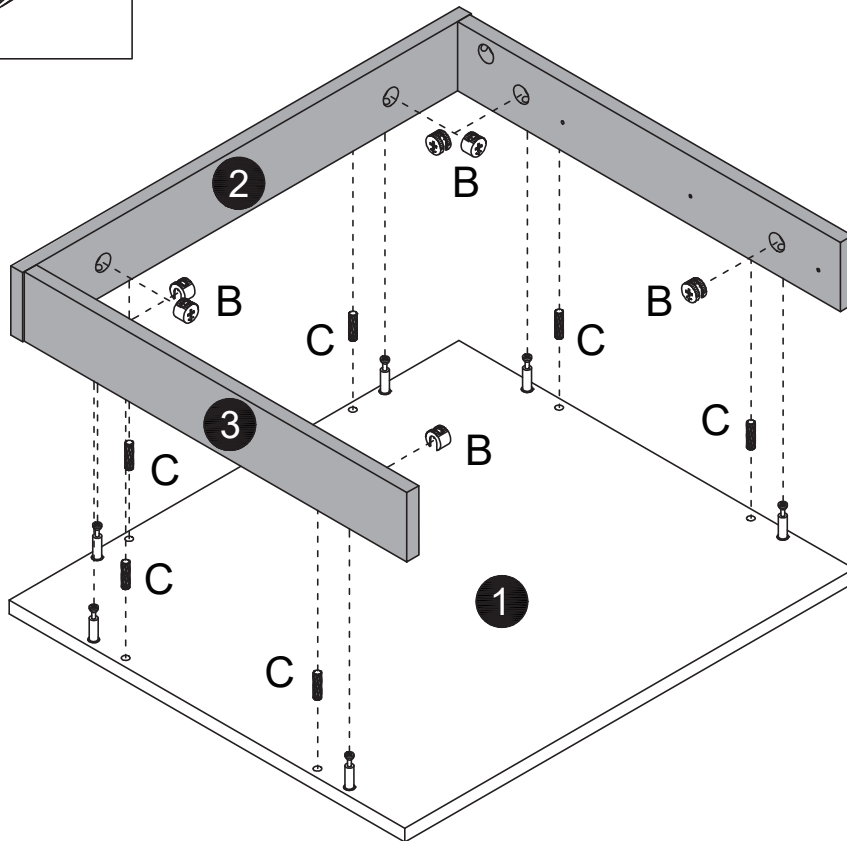

E x6

N1 x2

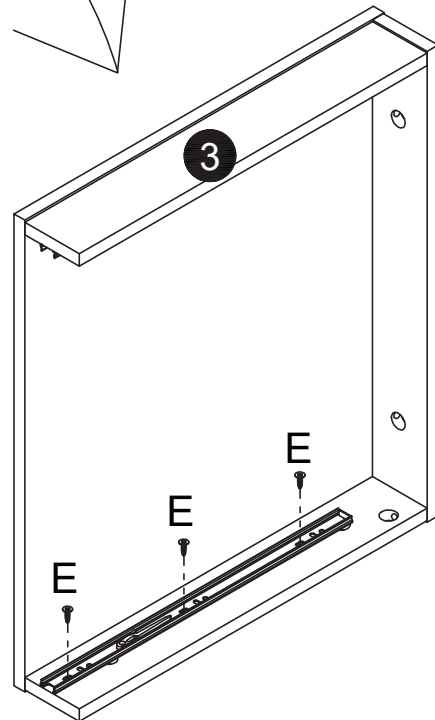
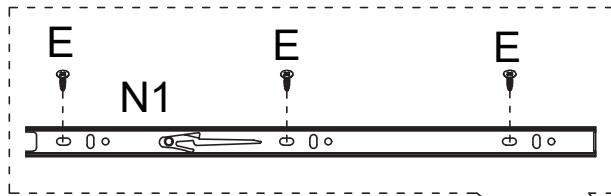
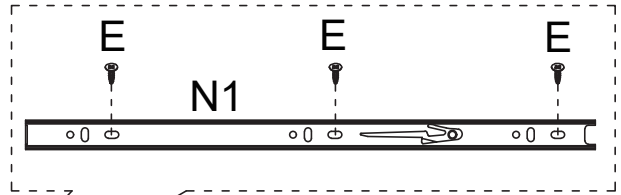
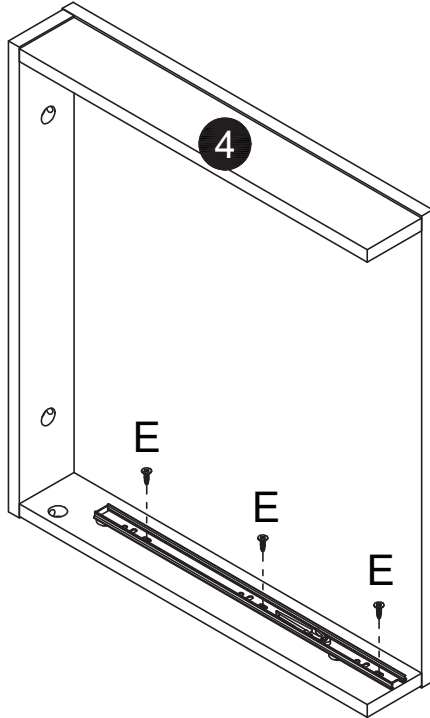

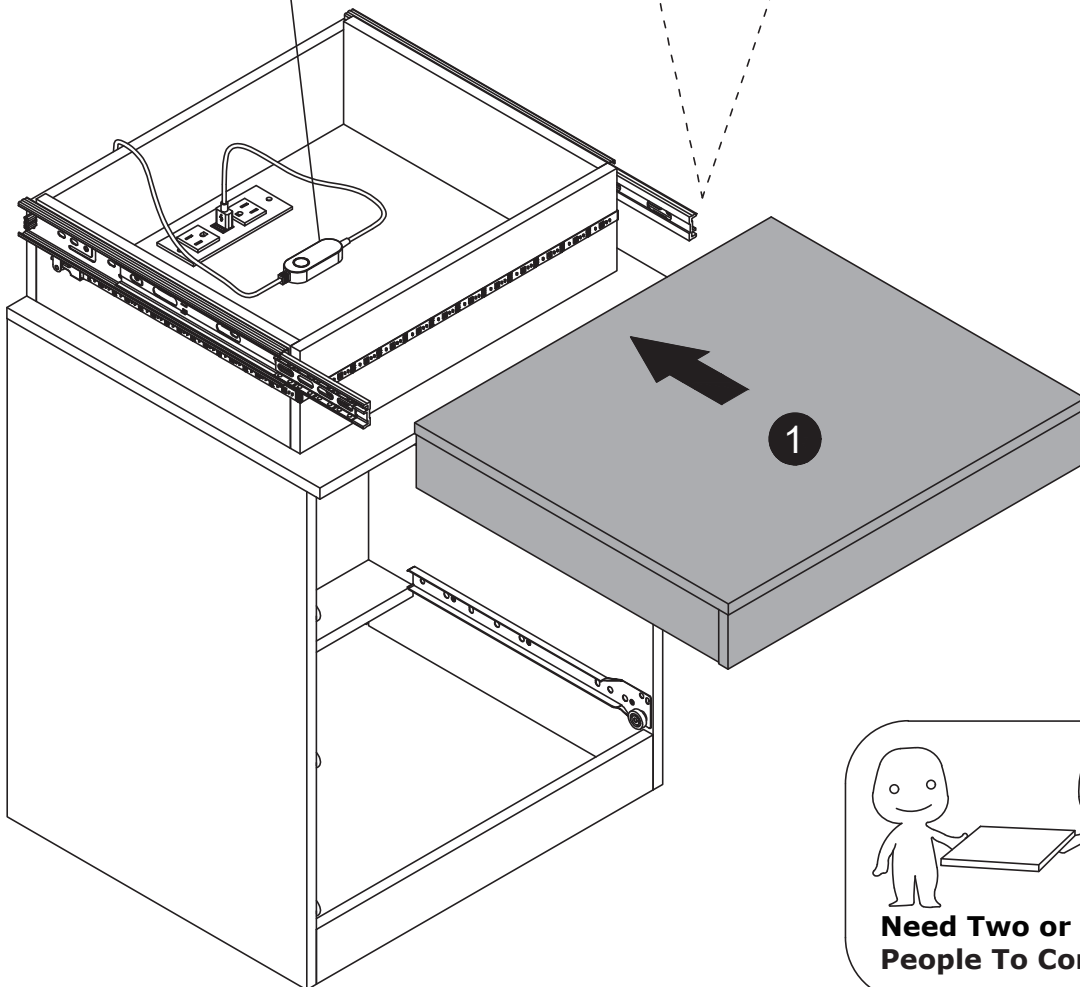
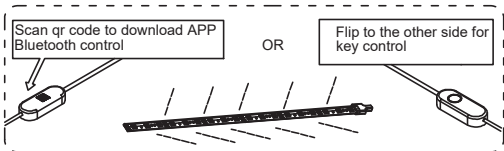
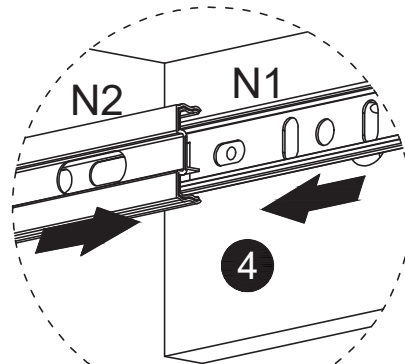
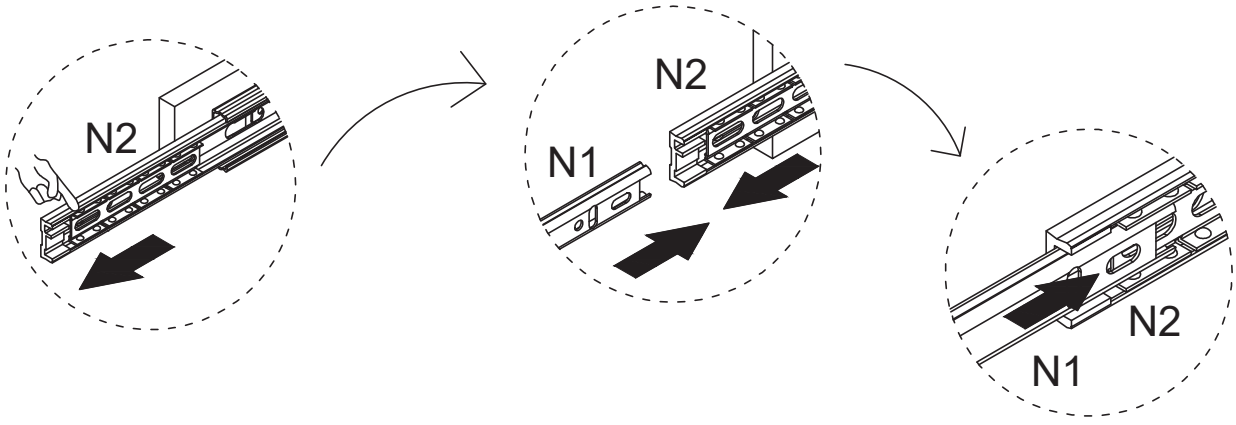

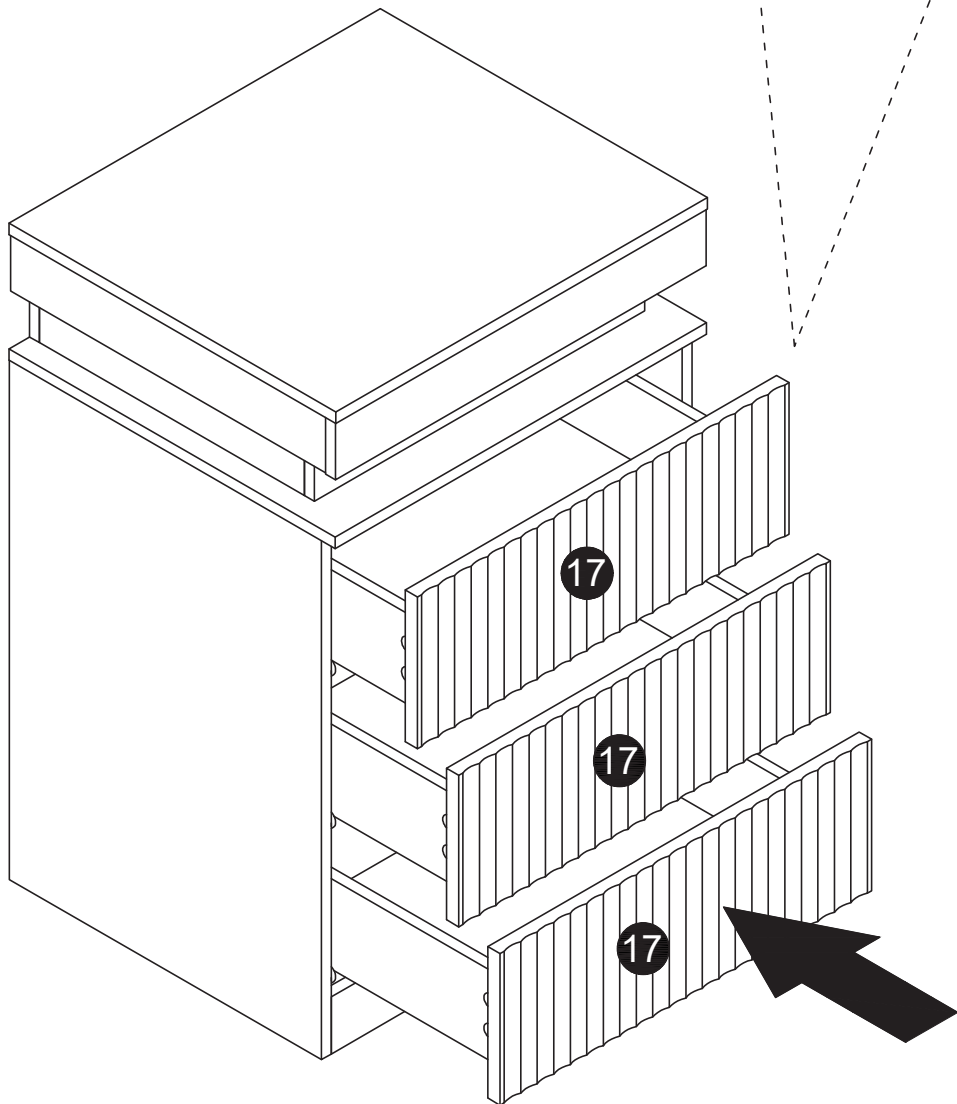
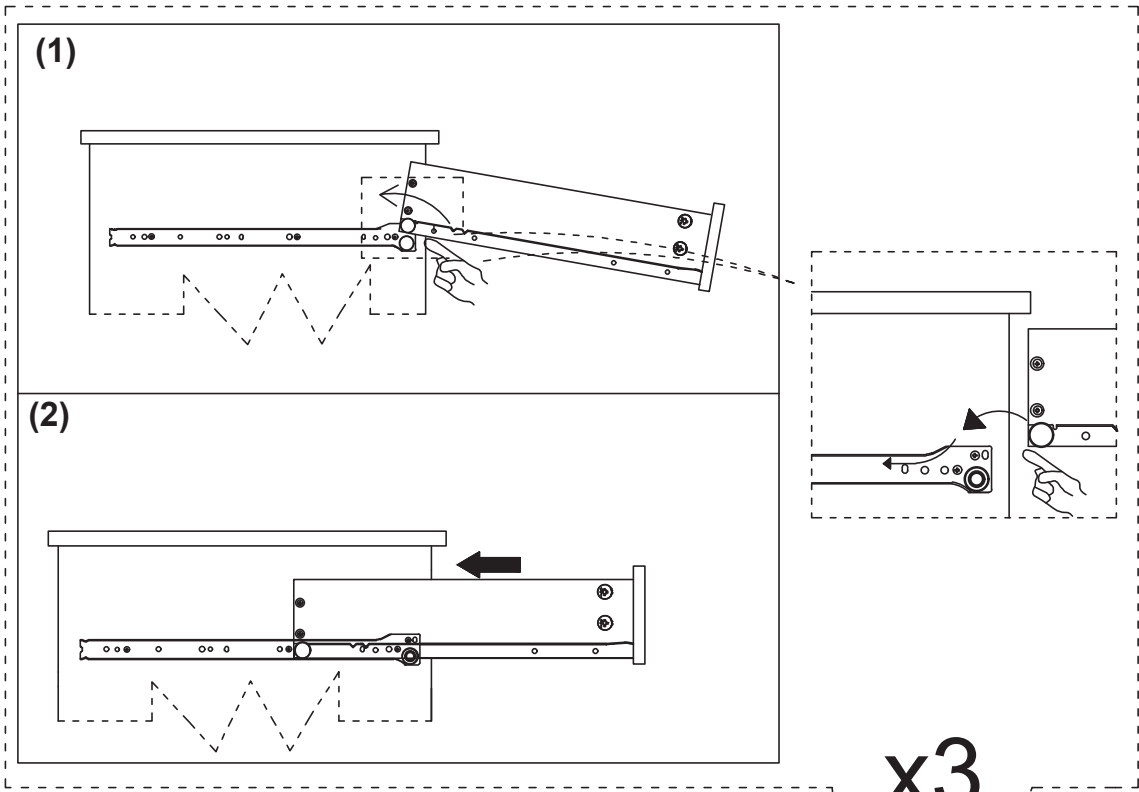

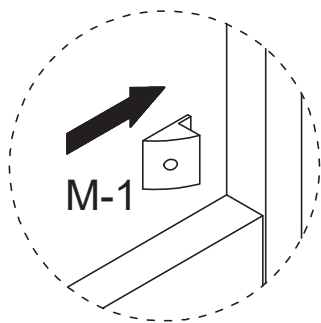
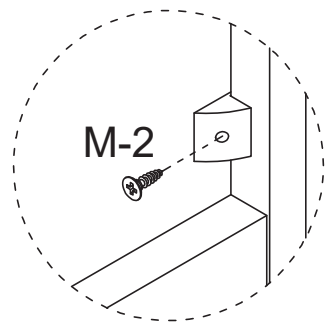
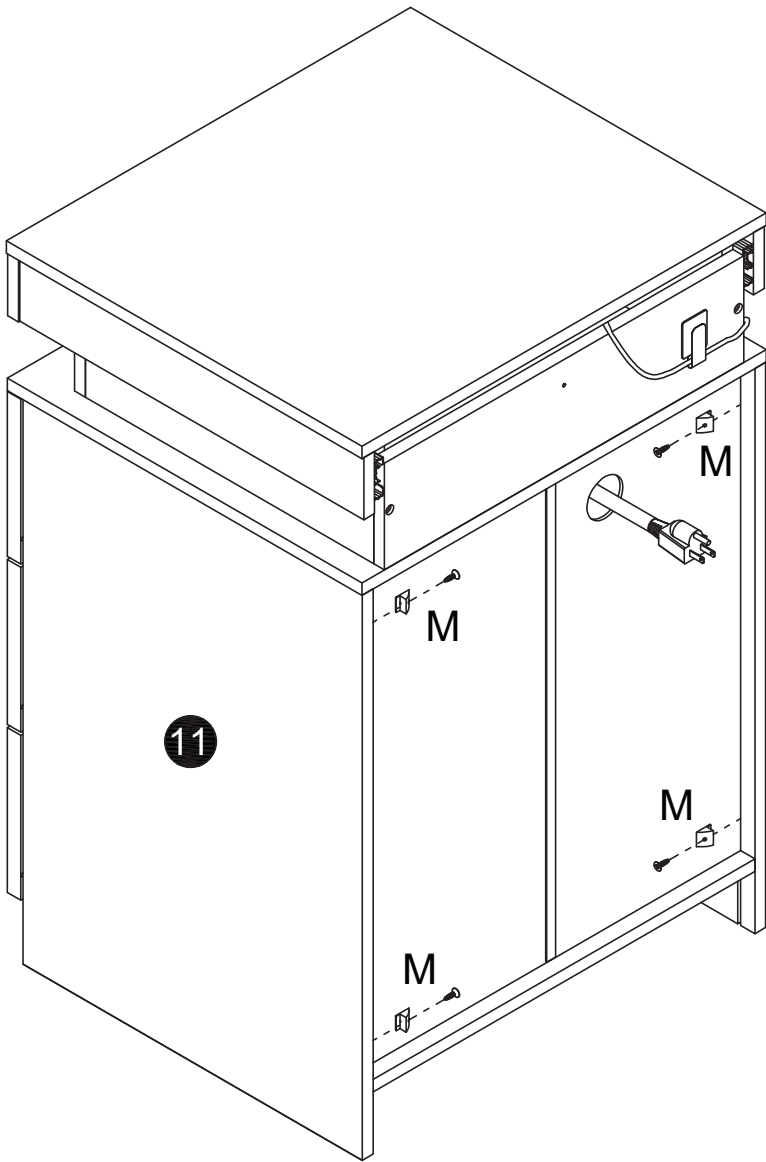
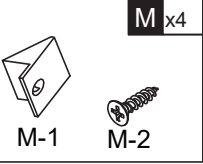

D x1

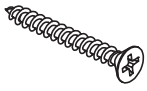

L x1

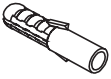

K x1

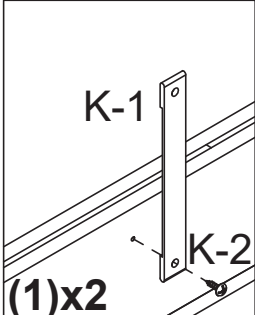
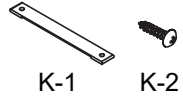

First fix the anti-rewind screw in the reserved hole of the product.

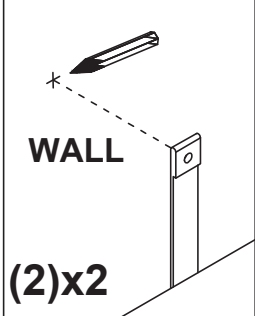

then, use a ruler to measure the approximate height of the product on the wall, and then mark it with a pen.

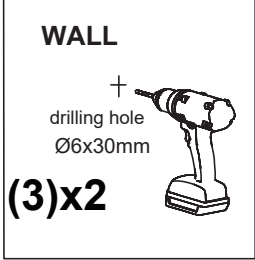

Then use a tape drill to make holes in the wall that are suitable for the product screws.

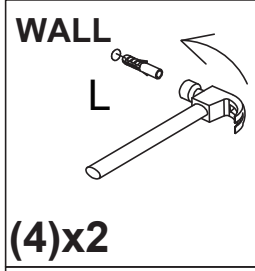

Then, put the expansion bolt into the hole

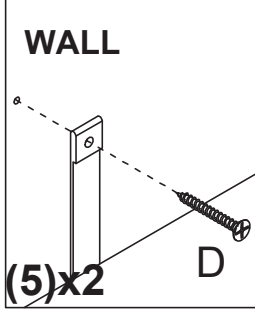

Finally, pass the matching screws through the "anti-rewind" and tighten them to fix them on the wall.

