

Student Desk

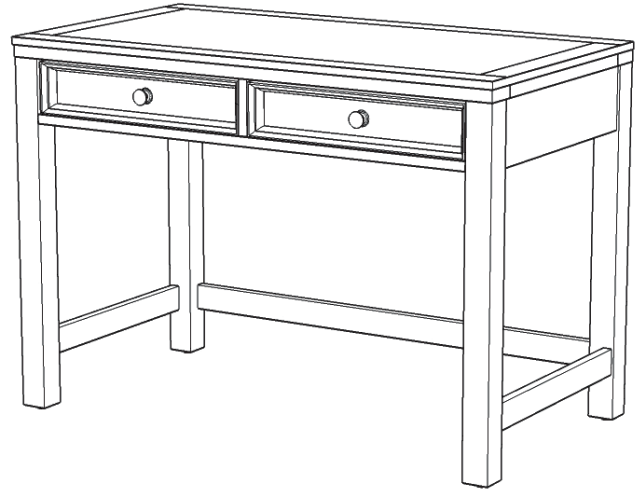

IMPORTANT

Carefully remove all the parts from the carton and place them individually on a soft cloth to prevent scratches or other damage.

Carefully and strictly follow these assembly instructions to ensure a completed product as designed.

Do not use power tools above 8 volts to assemble.

Part List

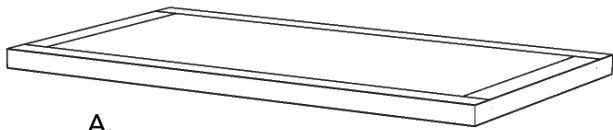

A.
Top
1 pc.



D.
Front Rail
1 pc.

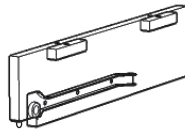

E.
Divider
1 pc.

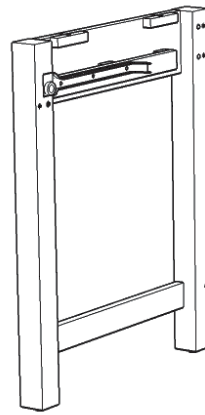

B.
Side Frame
1 pc.

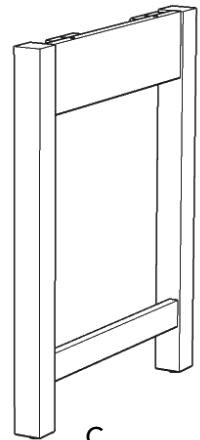

C.
Side Frame
1 pc.

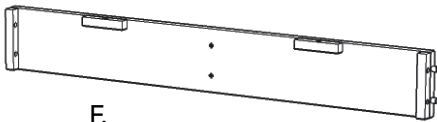

F.
Back Panel
1 pc.



G.
Stretcher
1 pc.

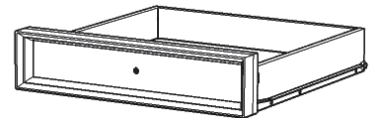

H.
Drawer
2 Pcs.

Refer to later page(s) of these instructions for drawer assembly.

Hardware List



Hex Wrench
1 pc.



Cam Lock
2 pcs. (+2 extra)



M6x35
Head Cap Bolt
12 pcs. (+1 extra)



Spring Washer
12 pcs. (+1 extra)



Flat Washer
12 pcs. (+1 extra)



Handle
2 pcs.



Small Hex Wrench
1 pc.



Cam Lock Screw
2 pcs. (+2 extra)



M3.5x38
Wood Screw
2 pcs. (+1 extra)



M3.5x25
Flat Head Screw
1 pcs. (+1 extra)



M4x22
Machine Screw
2 pcs.

Tool(s) required for assembly: Phillips screwdriver

Assembly Instructions 2/5

IMPORTANT

- Use a soft cloth between these parts and the floor.
- Do not use power tools above 8 volts to assemble.
- Do not tighten all the bolts until each part is properly assembled.
- The unit must be level to work properly. Use the included adjustable levelers to level.
- Keep Hex Wrench as the bolts may need to be tightened in the future.

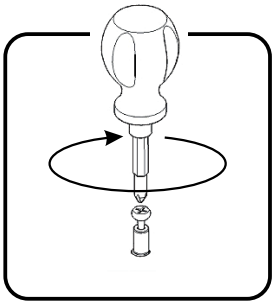
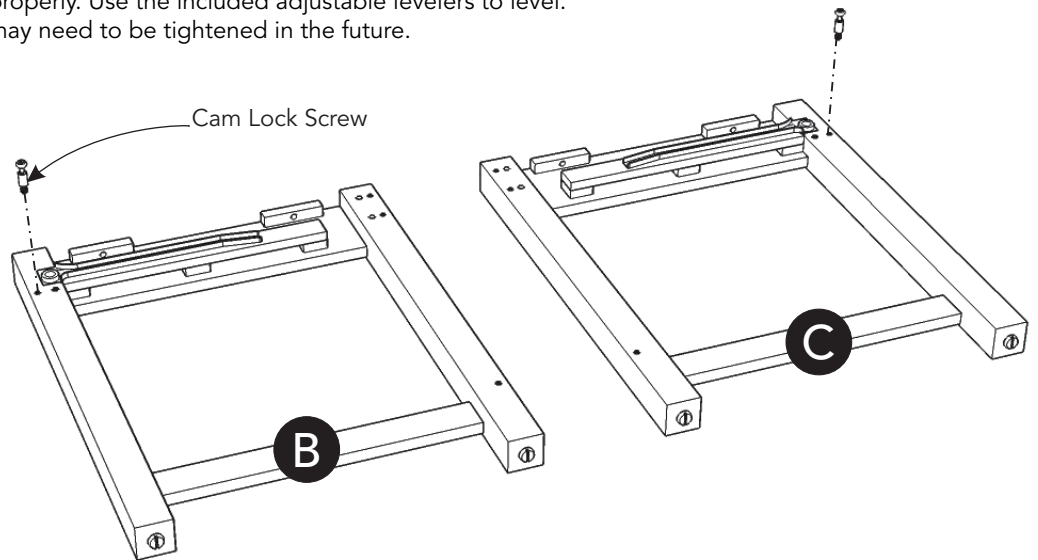
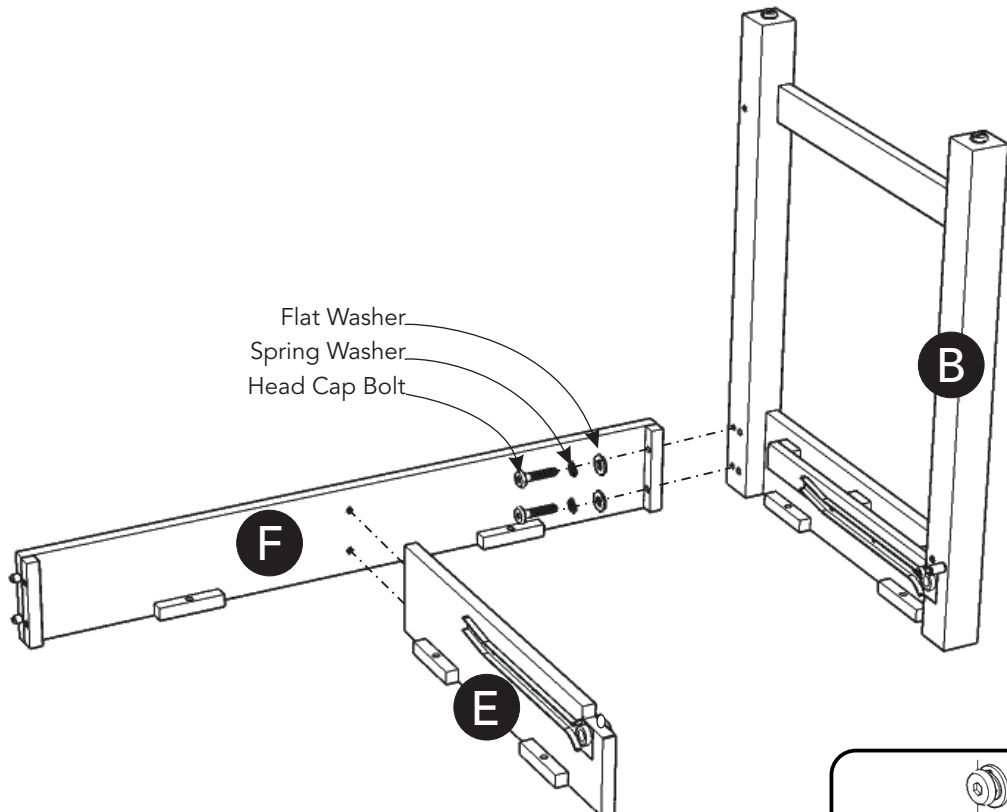

Figure 1



STEP 1

Insert Cam Lock Screws into pre-drilled holes in Side Frames (B) and (C), then tighten.
(See Figure 1)



STEP 2

Attach Back Panel (F) to Side Frame (B) with Head Cap Bolts, Spring Washers and Flat Washers.
(See Figure 2)

Attach Divider (E) to unit.

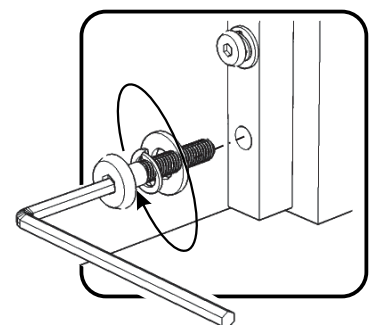

Figure 2

Assembly Instructions 3/5

STEP 3

Attach Front Rail (D) to unit with Cam Lock and Flat Head Screw.
(See Figures 3)

Attach Stretcher (G) to unit with Wood Screw.
(See Figure 4)

Attach Side Frame (C) to unit with Cam Lock, Wood Screw, Head Cap Bolts, Spring Washers and Flat Washers.

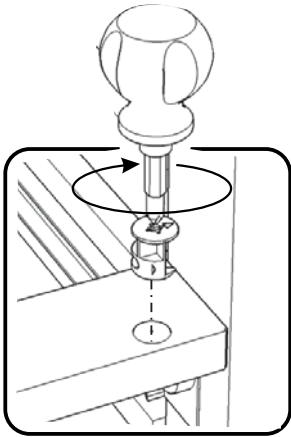
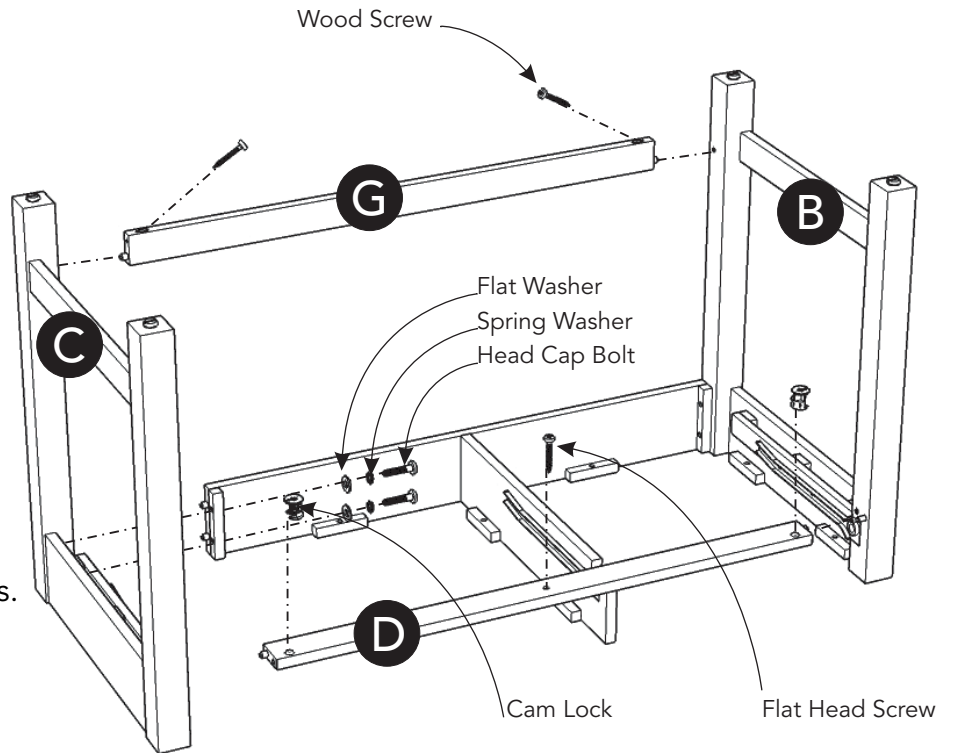

Figure 3

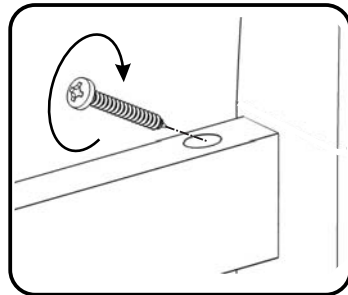
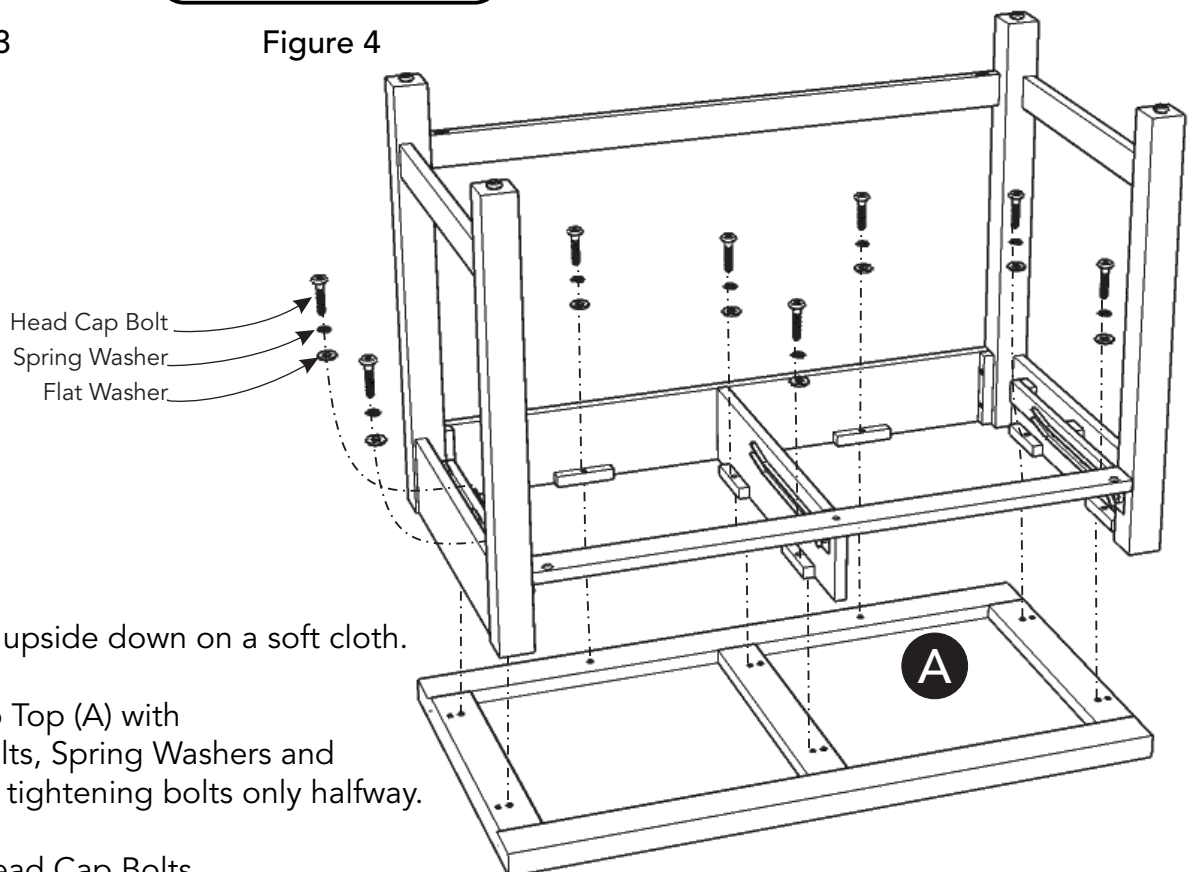

Figure 4



STEP 4

Place Top (A) upside down on a soft cloth.

Attach unit to Top (A) with Head Cap Bolts, Spring Washers and Flat Washers, tightening bolts only halfway.

Tighten all Head Cap Bolts.

Assembly Instructions 4/5

Drawer (H)

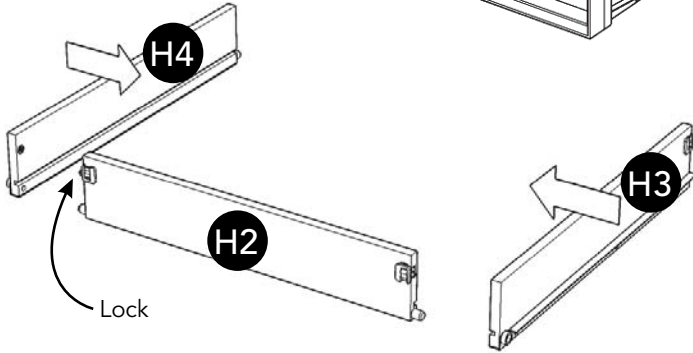
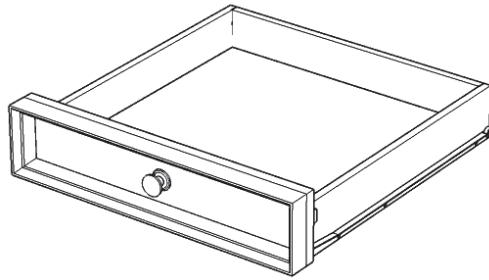

STEP 5

Attach Drawer Sides (H3) and (H4) to Drawer Back (H2), then flip the Locks. (See Figures 5 and 6)

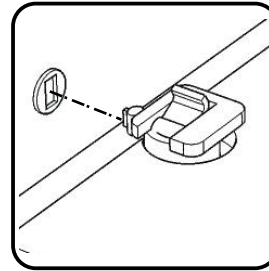

Figure 5

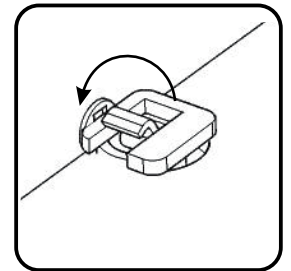
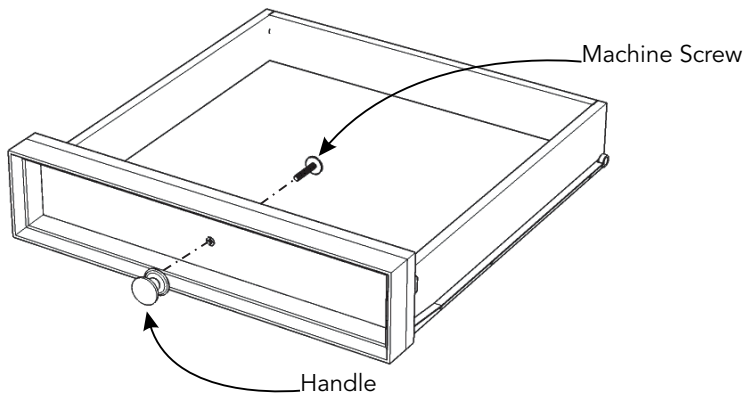
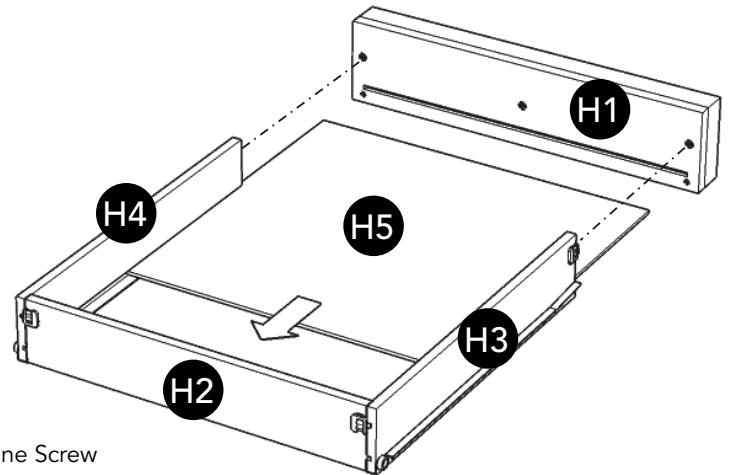

Figure 6

STEP 6

Slide Drawer Bottom (H5) into grooves in Drawer Sides (H3) and (H4) until it meets Drawer Back (H2).

Attach Drawer Front (H1) to unit, then flip the Locks.



STEP 7

Attach Handle with Machine Screw.

Part List

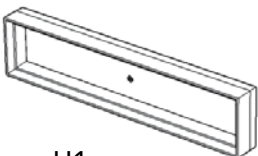

H1.
Drawer Front
2 pcs.

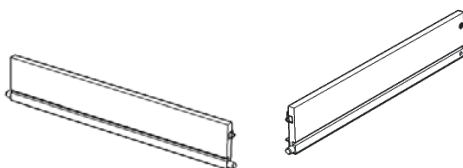

H2.
Drawer Back
2 pcs.

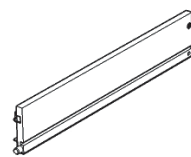

H3.
Drawer Side
2 pcs.

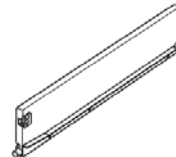

H4.
Drawer Side
2 pcs.

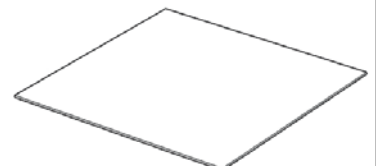

H5.
Drawer Bottom
2 pcs.

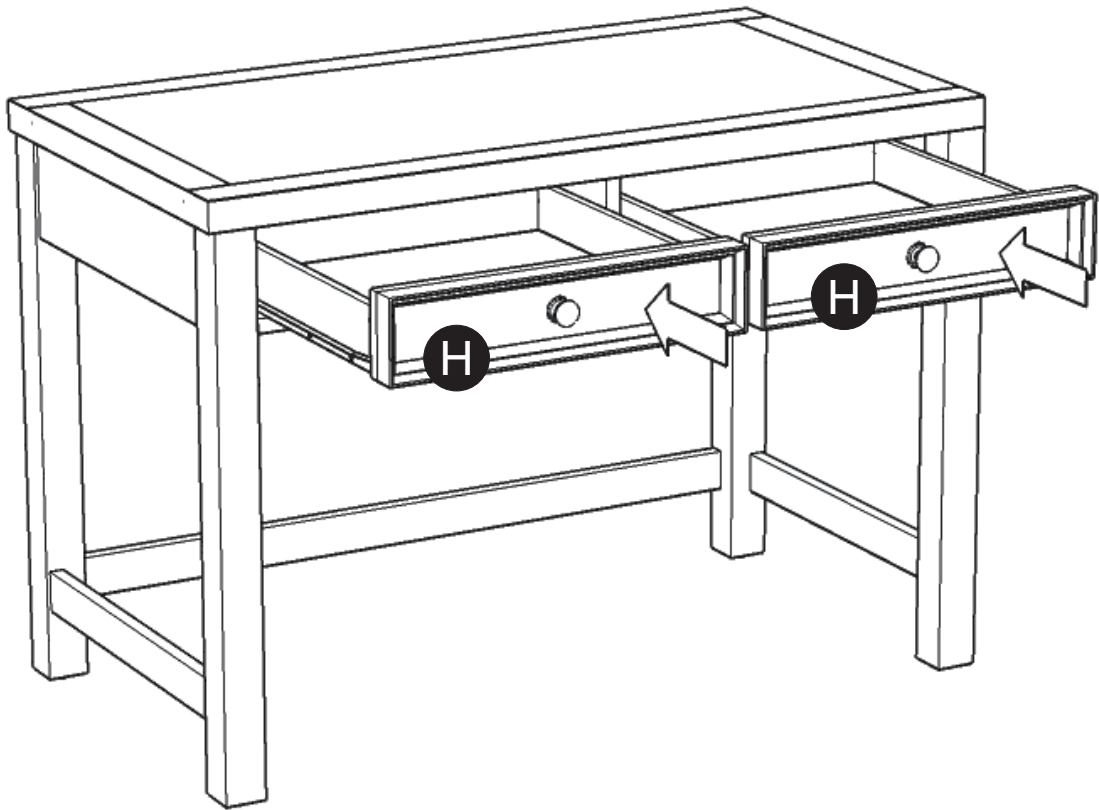

STEP 8

Turn unit to its' upright position.

Slide Drawers (H) into position.

Level unit by adjusting the adjustable levelers on bottom of unit.
(See Figure 7)

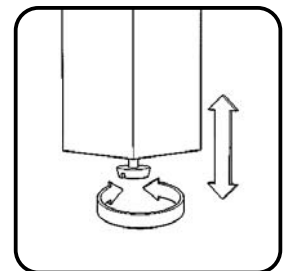

Figure 7

CARE INSTRUCTIONS

NEVER

allow liquids to remain on furniture.
Absorption causes parts to warp
and split and finishes to delaminate.

NEVER

use glass cleaners on
finished furniture. Ammonia
chemically attacks the finish.



Do not use power tools
above 8 volts to assemble.
**PREVENT
CRACKING**



Do not place
in direct sunlight.
**PREVENT
FADING**



Do not write
directly on surface.
**PREVENT
MARKING**



Do not place hot
objects on surface.
**PREVENT
FINISH DAMAGE**

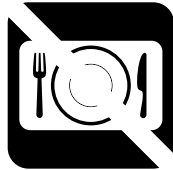

Do not use rubber
based placemats.
**PREVENT
DISCOLORING**



Do not use commercial
waxes and polishes.
**PREVENT
YELLOWING**

CLEAN

with a soft cloth moistened
in lukewarm soap and water.
Buff with a dry clean cloth.

