

ATTENTION

PLEASE READ BEFORE OPENING + ASSEMBLING

TWIN/ FULL LOW BUNK BED
LIT SUPERPOSÉ BASE JUMEAUX/DOUBLE
LITERA BAJA INDIVIDUAL/DOBLE

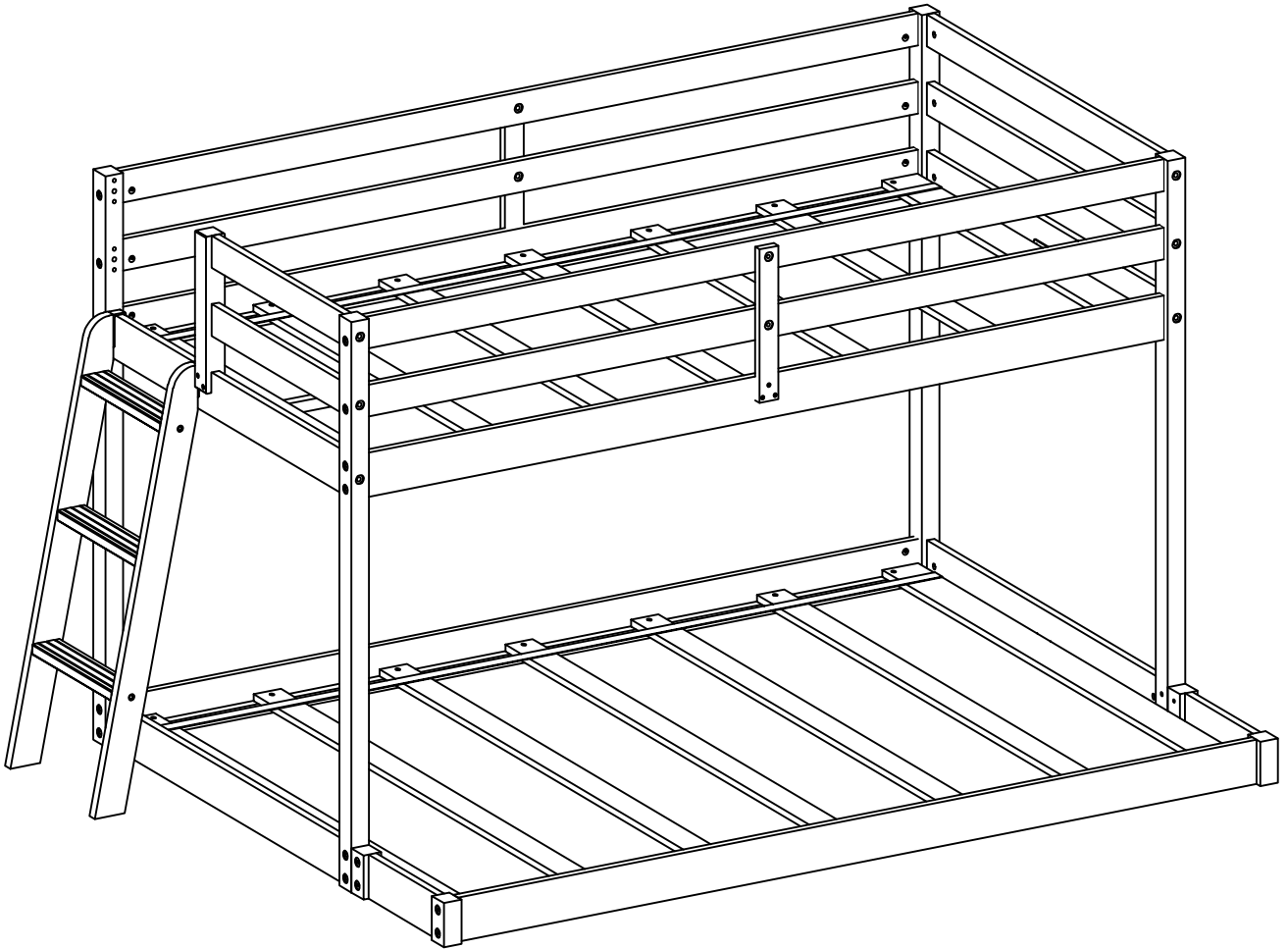

Left
Gauche
Izquierda

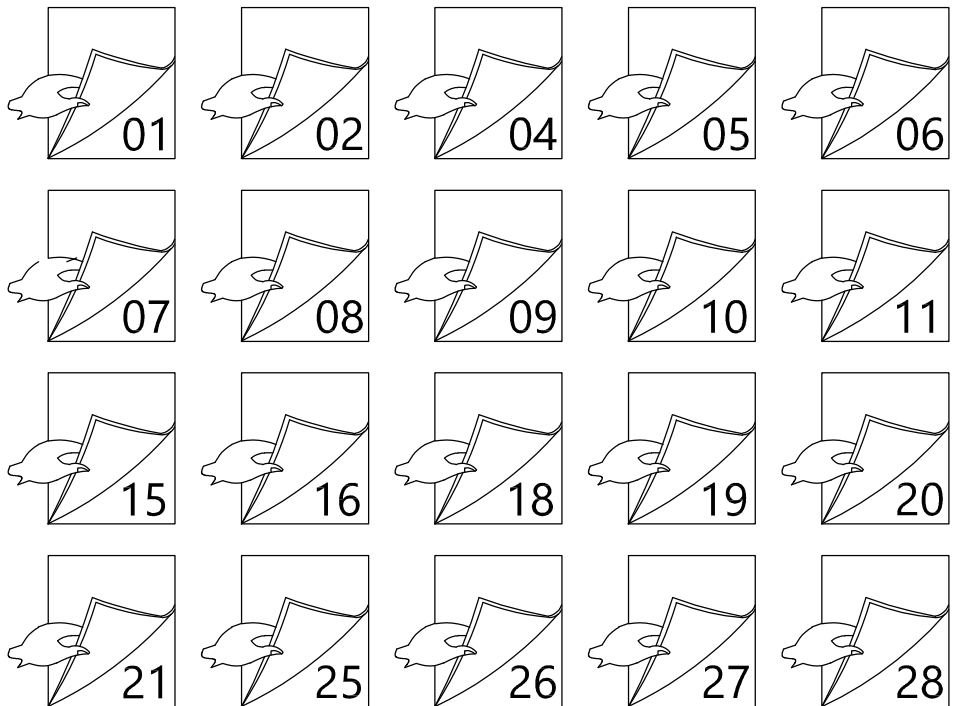
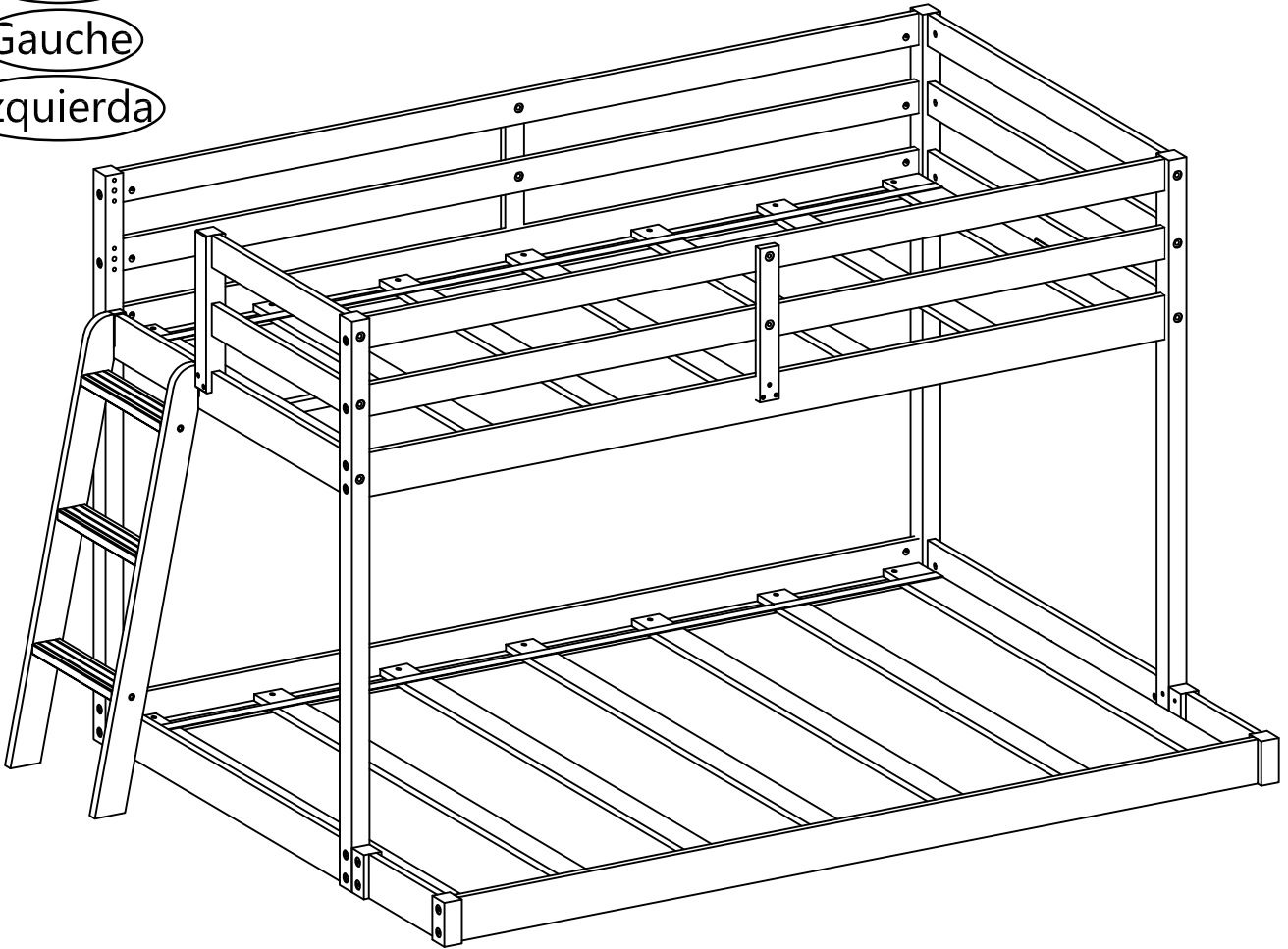

Right
Droit
Derecha

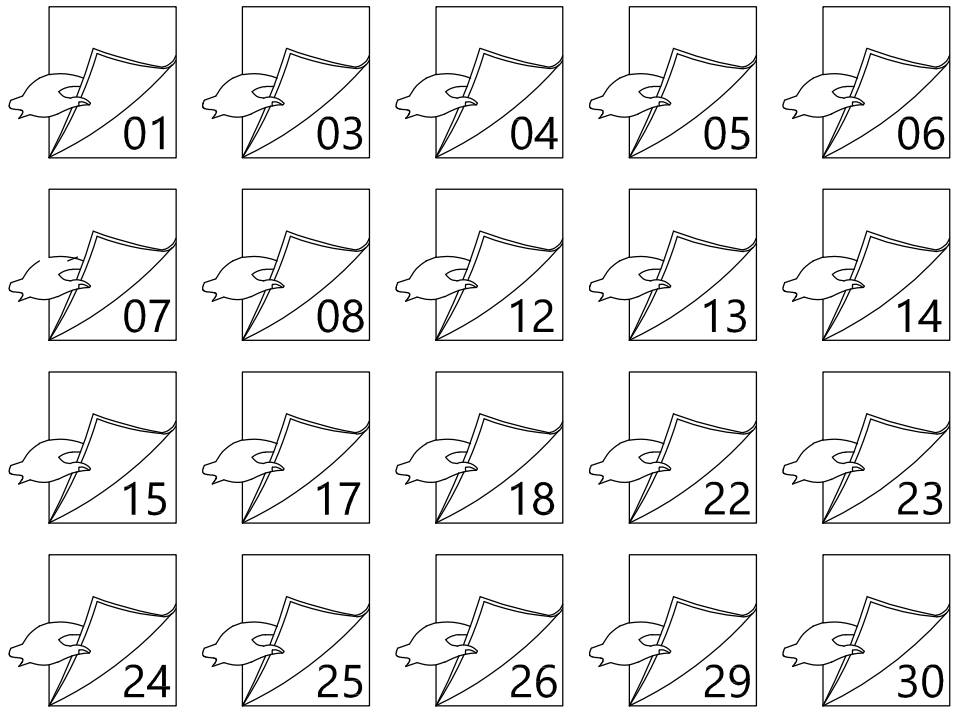
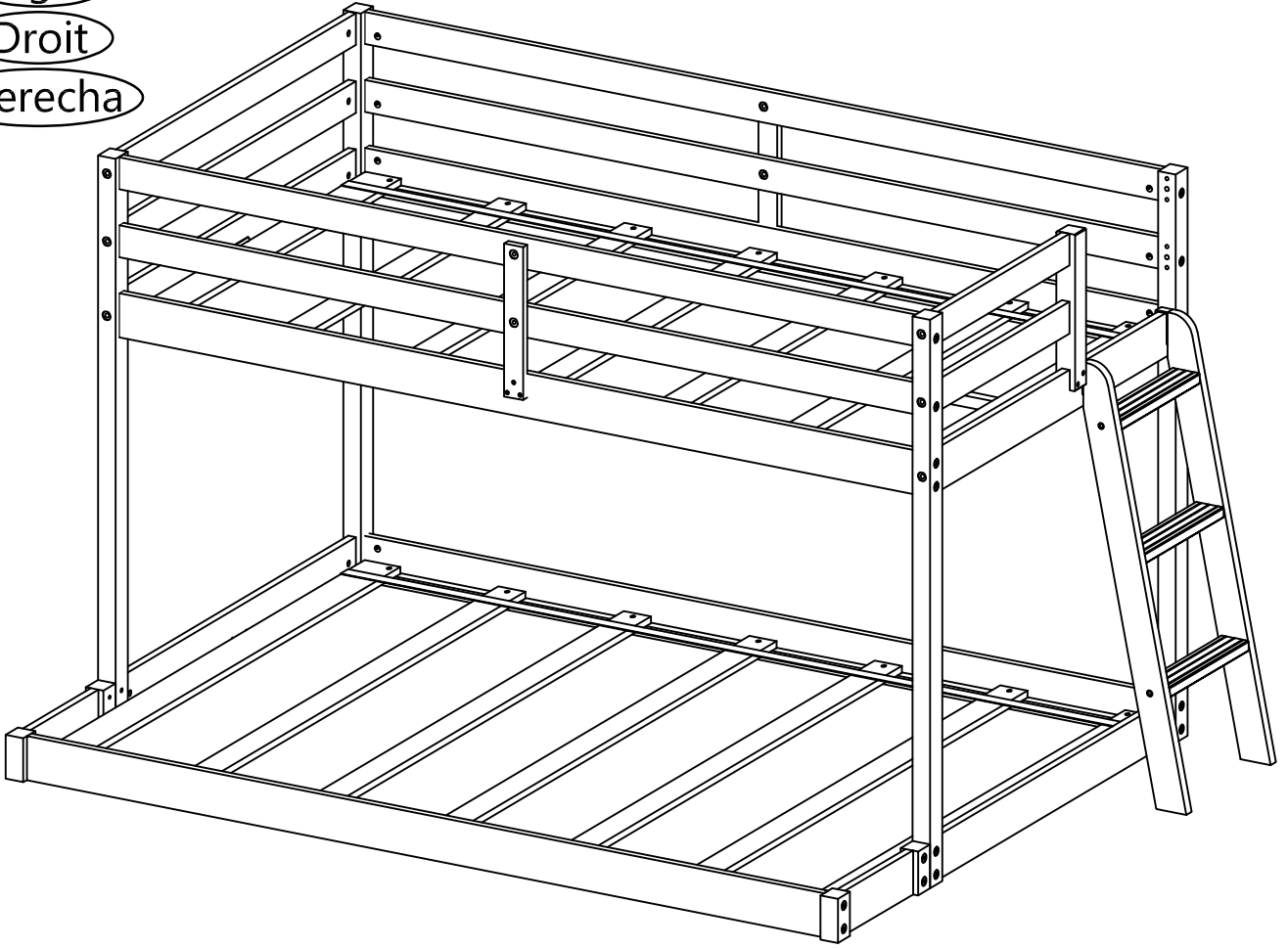

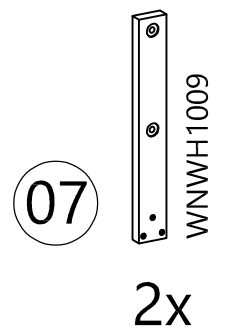
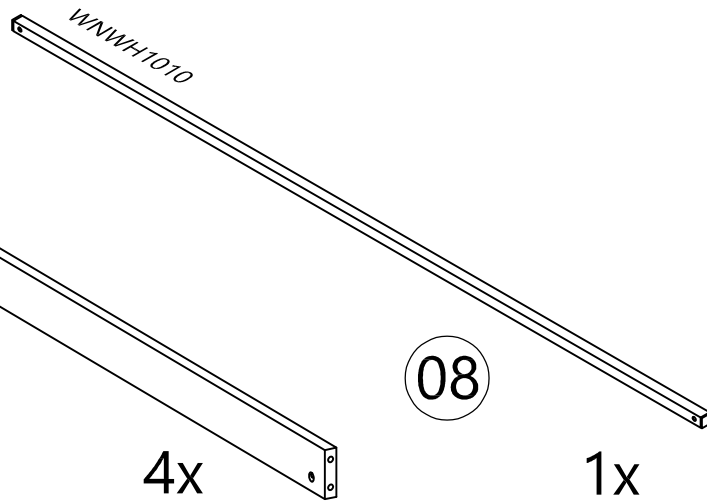
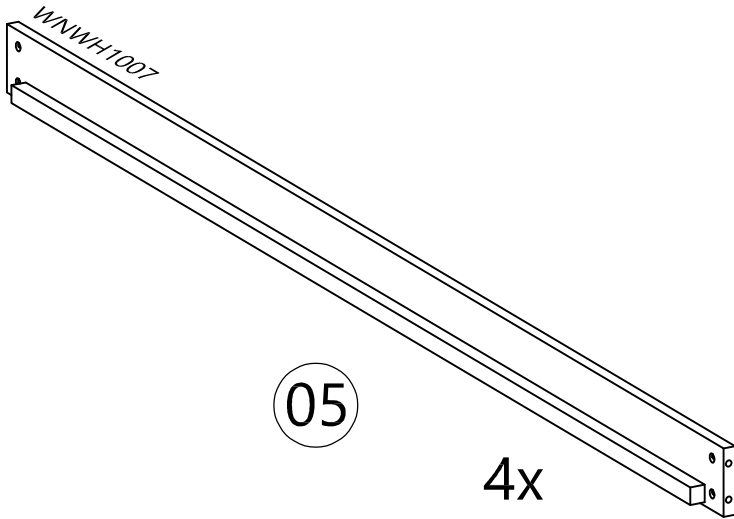
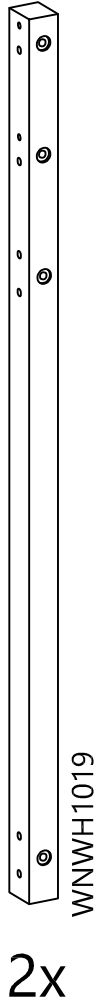
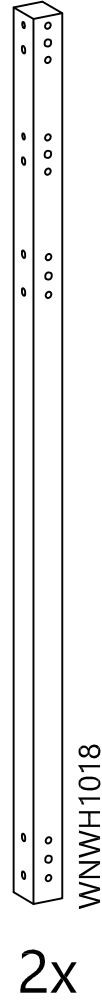
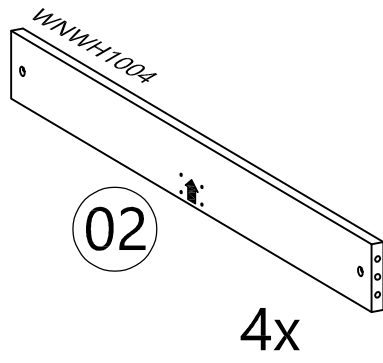
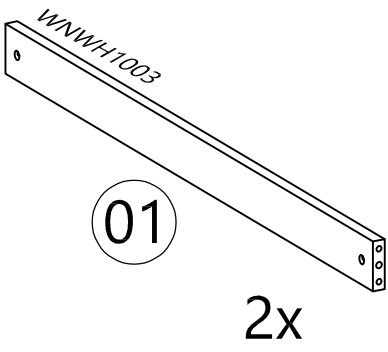

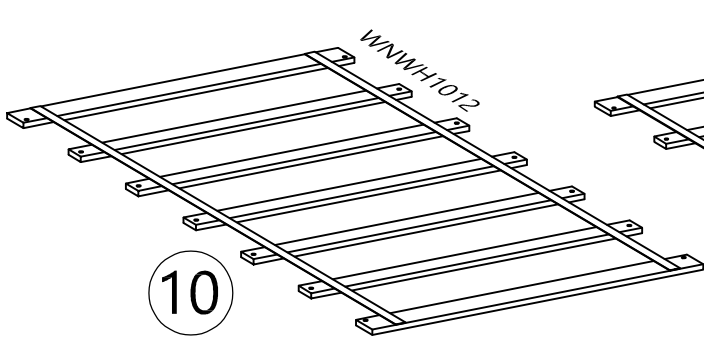

10

1x

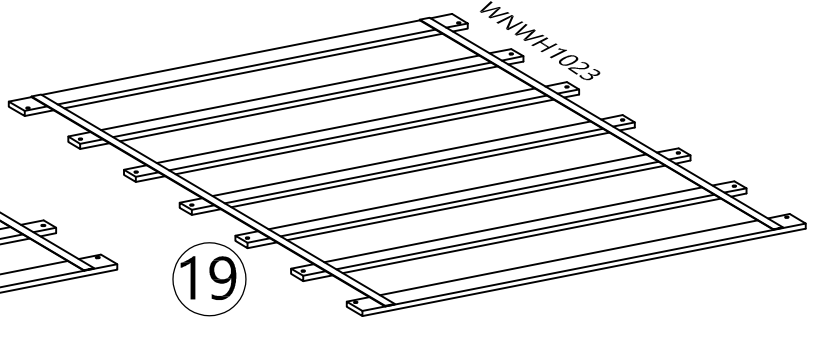

19

1x

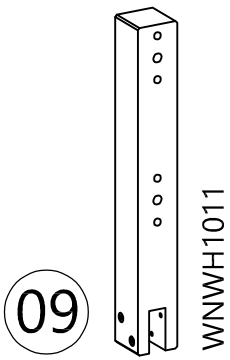

09

1x

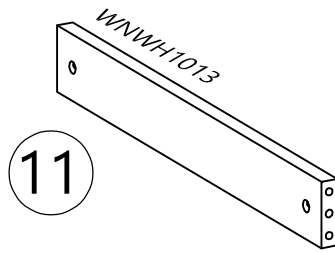

11

2x

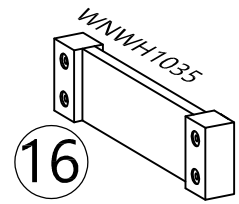

16

2x

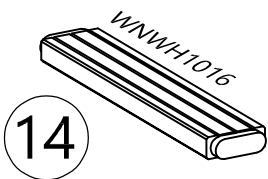

14

1x

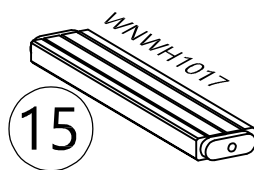

15

2x

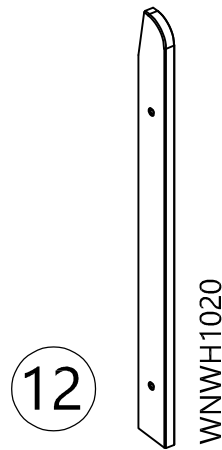

12

1x

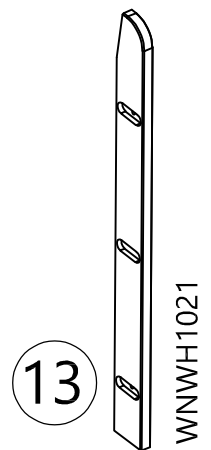

13

1x

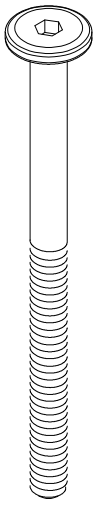

HW20701 (M8*90mm)

40x



HWD20436 (M8*40mm)

10x



HW21797 (M8*25mm)

4x

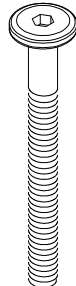

HW20912 (M6*65mm)

4x

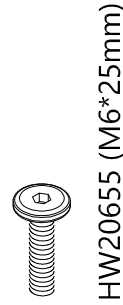

HW20655 (M6*25mm)

2x



HW200012 (M8*15mm)

40x



HW20591 (M6*13mm)

4x

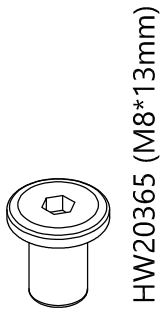

HW20365 (M8*13mm)

14x

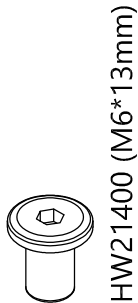

HW21400 (M6*13mm)

2x



HW20010 (3*15mm)

8x



HW20012 (3*19mm)

2x



HW20055 (4*30mm)

38x



HW20343 (4*25mm)

4x

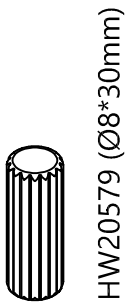

HW20579 (Ø8*30mm)

40x



HWD20037 (Ø9mm)

4x

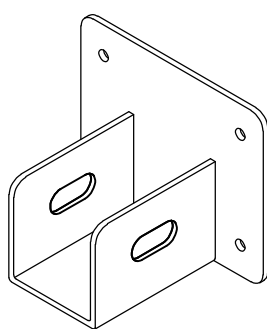

HW20674 (45*76*25mm)

2x

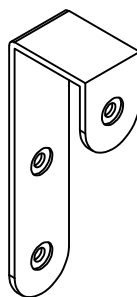

HW20905 (72*26*21mm)

2x

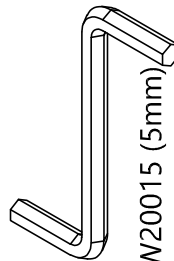

HW20015 (5mm)

2x

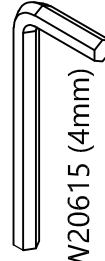

HW20615 (4mm)

2x

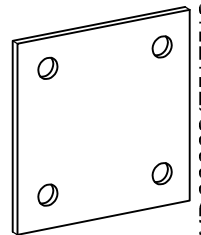

HWD00003(75*75*3mm)

2x

⚠ WARNING:

CHOKING HAZARD
Small Parts
Not for children under 3 years.
To be Assembled by an Adult

⚠ ATTENTION:

RISQUE D'ÉTOUFFEMENT
Petites parties
Ne convient pas aux enfants de
moins de 3 ans.
Doit être assemblé par un adulte

⚠ ADVERTENCIA

PELIGRO DE ASFIXIA
Partes pequeñas
No apta para niños menores
de 3 años
A ser ensamblado por un adulto

Not Included
Non Inclus
No Incluido

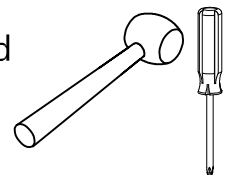

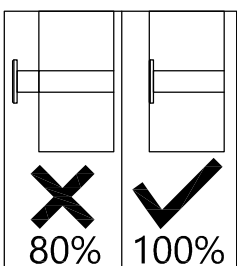
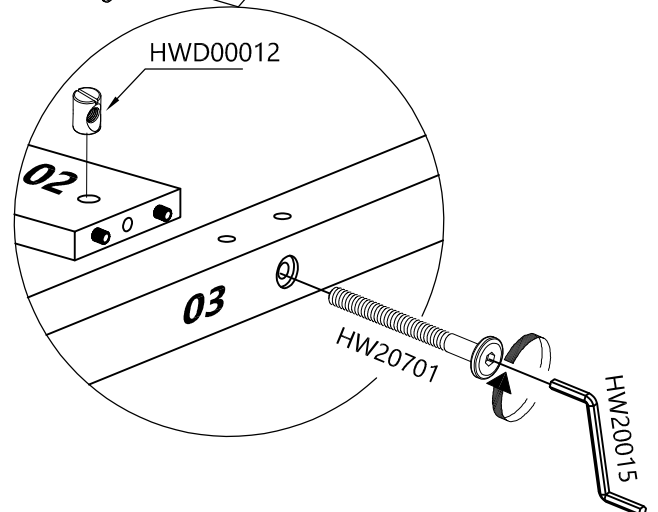
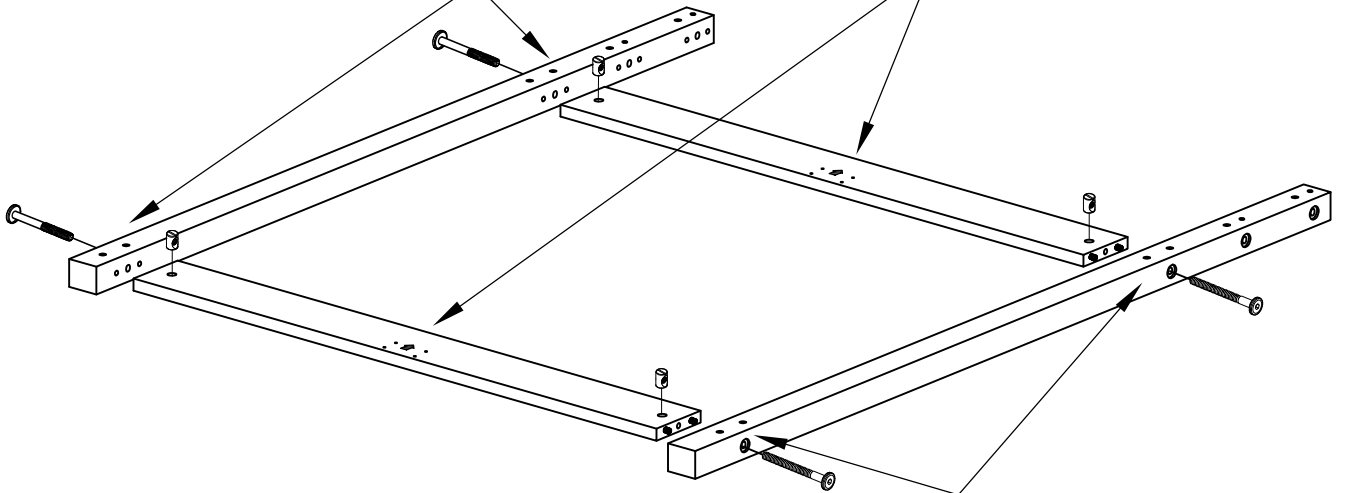
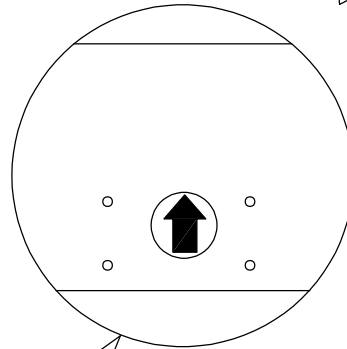
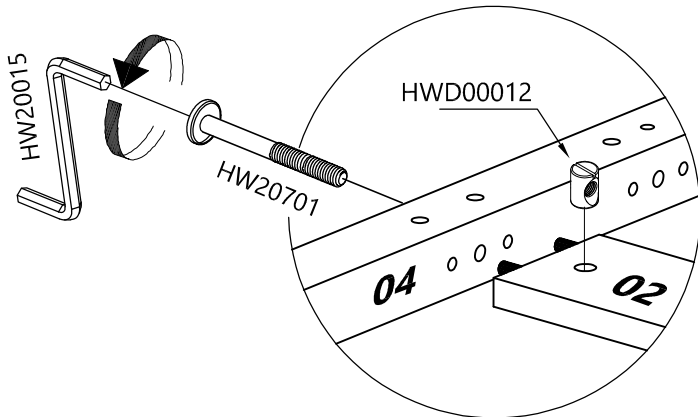
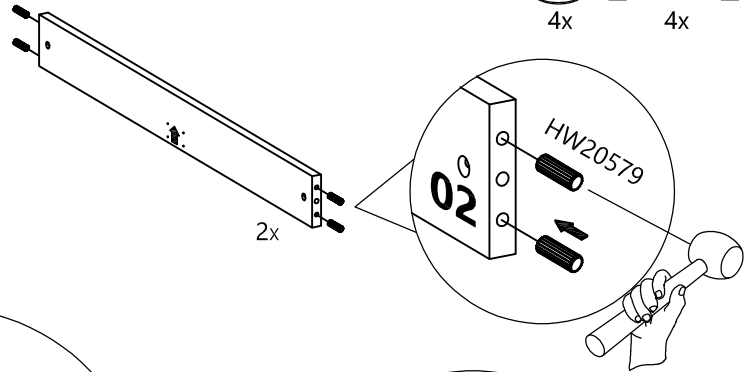
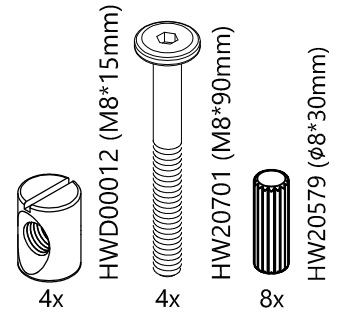
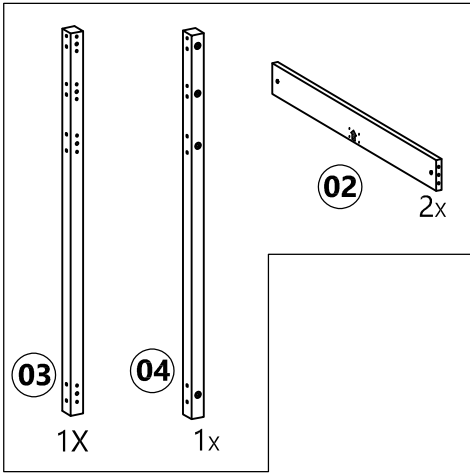

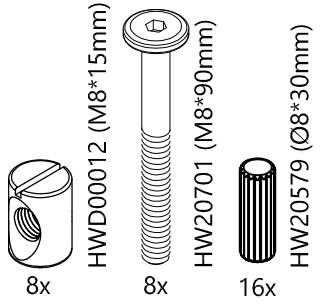
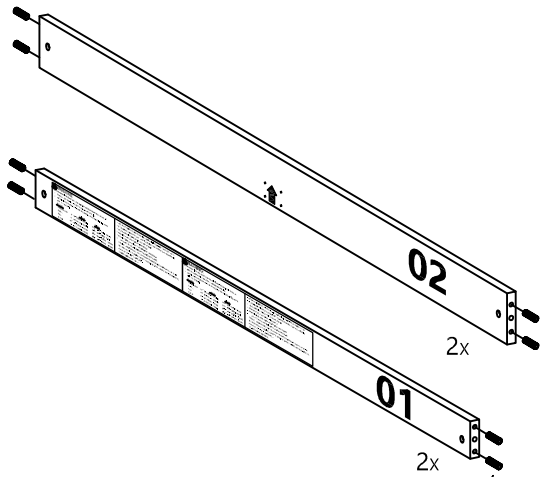
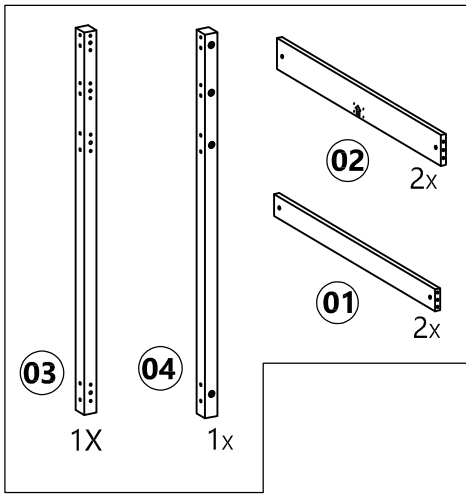

Manufacturer: Yu Sern Furniture Industrial Co., Ltd, Trang Bom District, Vietnam
 Importer: Maxwood Furniture Inc., Charleston, SC 29492, USA.
 Item# :3400110000-xxx, Prod. Date: _____, Made in Vietnam
 Section 103 Consumer Product Safety Improvement Act (CPSIA)
 CALIFORNIA 93120 PHASE 2 COMPLIANT FOR FORMALDEHYDE
 COMPLIANT WITH EPA 40 CFR 770 - TSCA VI REQUIREMENT FOR FORMALDEHYDE
This is a permanent label. Do not attempt to remove.

⚠ WARNING:

TO HELP PREVENT SERIOUS OR FATAL INJURIES FROM ENTRAPMENT OR FALLS:
 • NEVER ALLOW A CHILD UNDER 6 YEARS ON UPPER BUNK.
 • USE ONLY MATTRESS MEETING THE FOLLOWING SPECIFICATIONS ON UPPER AND LOWER BUNK:
 BED TYPE: TWIN STANDARD (74" - 75" (188CM - 190CM)), FULL (74" - 75" (188CM - 190CM)), QUEEN (74" - 75" (188CM - 190CM))
 MATH XL (74" - 75" (188CM - 190CM))
 WIDTH: 37 1/2" - 38 1/2" (95CM - 98CM), 37 1/2" - 38 1/2" (95CM - 98CM), 52 1/2" - 53 1/2" (134CM - 136CM), 59 1/2" - 60 1/2" (151CM - 154CM)

• INSURE THE THICKNESS OF MATTRESS AND FOUNDATION COMBINED DOES NOT EXCEED 9" (23CM) AND MATRESS IS AT LEAST 3" (7.5CM) BELOW UPPER EDGE OF GUARDRAILS
 • USE GUARDRAILS ON BOTH SIDES OF UPPER BUNK
 • PROHIBIT HANGING ON OR UNDER BEDS
 • PROHIBIT MORE THAN ONE PERSON ON THE UPPER BUNK
 • USE ADAPTER FOR BREASTING AND LEAVING UPPER BUNK STRANGLATION HAZARD - NEVER ATTACH OR MAKE TIE-INS TO ANY PART OF THE BUNK BED THAT ARE NOT DESIGNED FOR USE WITH THIS BED. FOR EXAMPLE, BUT NOT LIMITED TO, HOOKS, BELTS AND "LUMPHORNERS".
 • DO NOT REMOVE THIS LABEL.

⚠ MISS EN GRADE!

POUR AIDER PREVENIR SERIEUX OU FATALE BLESSES D'ENFERMEMENT OU DE CHUTES:
 • NE JAMAIS LASSER UN ENFANT DE MOINS DE 6 ANS SUR LE SUPERIEUR.
 • UTILISER UN EQUIPEMENT DES MATELAS RECOMMANDÉ AUX SPECIFICATIONS SUIVANTES SUR LES LITS SUPERIEURS SUPERIEUR ET INFÉRIEUR:
 TYPE DE LIT: TWIN STANDARD (74" - 75" (188CM - 190CM)), FULL (74" - 75" (188CM - 190CM)), QUEEN (74" - 75" (188CM - 190CM)), MATH XL (74" - 75" (188CM - 190CM))
 LARGEUR: 37 1/2" - 38 1/2" (95CM - 98CM), 37 1/2" - 38 1/2" (95CM - 98CM), 52 1/2" - 53 1/2" (134CM - 136CM), 59 1/2" - 60 1/2" (151CM - 154CM)

• ASSUREZ-VOUS QUE L'ÉPAISSEUR COMBINÉE DU MATELAS ET LA FONDATION DÉPASSE PAS 9" (23CM) SUR LES LITS SUPERIEURS SUPERIEUR ET INFÉRIEUR ET QUE LE MATELAS EST À AU MOINS 3" (7.5 CM) EN DESSOUS DU BORD SUPÉRIEUR DU GARDE-CORPS.
 • UTILISEZ DES GARDE-CORPS DES DEUX CÔTÉS DU LIT SUPÉRIEUR.
 • INTERDIRE LE CACHAÛT SUR ET SOUS LE LIT(S).
 • INTERDIRE PLUS D'UNE PERSONNE SUR UN SUPÉRIEUR.
 • UTILISEZ L'ÉCHELLE POUR MONTRE ET SORTIR LE SUPÉRIEUR.
DANGER D'ÉTRANGLEMENT: NE JAMAIS ATTACHER OU ACCROCHER DES OBJETS À UNE PARTIE DU LIT SUPÉRIEUR QUI NE SOIT PAS CONÇU POUR ÊTRE UTILISÉ AVEC LE LIT PAR EXEMPLE, MAIS SANS S'Y LIMITER, DES RINGIÈRES, DES CEINTURES ET DES CORDES À SAUTER.
NO RETIRES PAS CETTE TIQUETTE

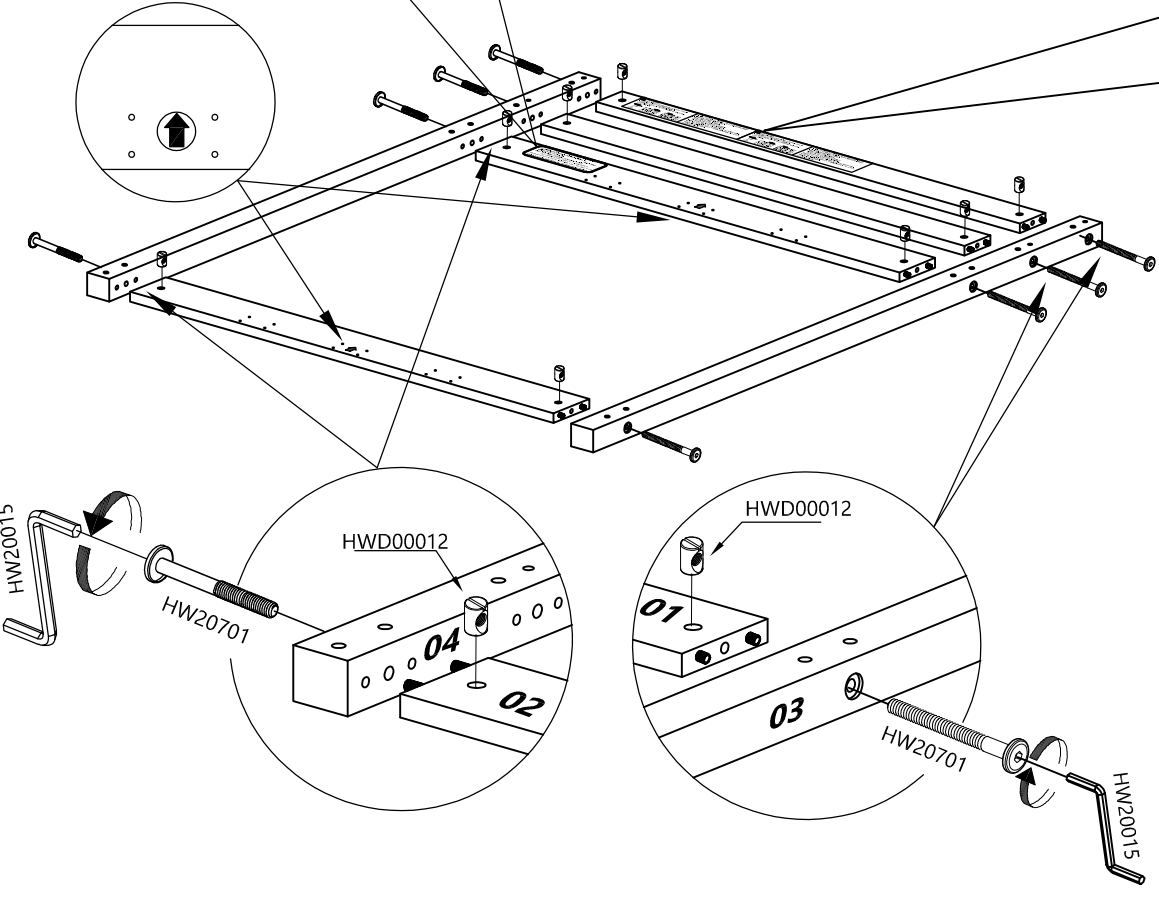

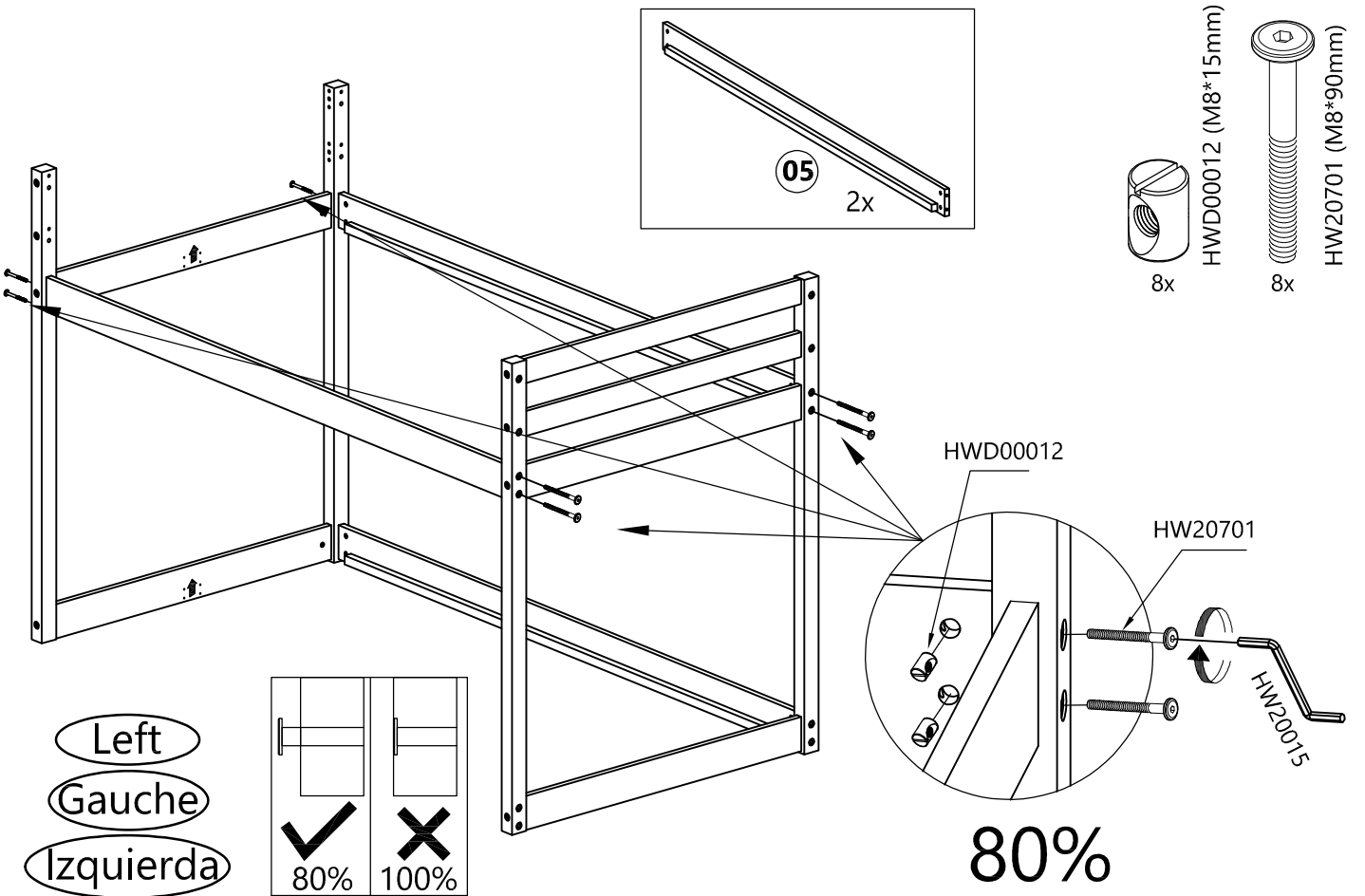
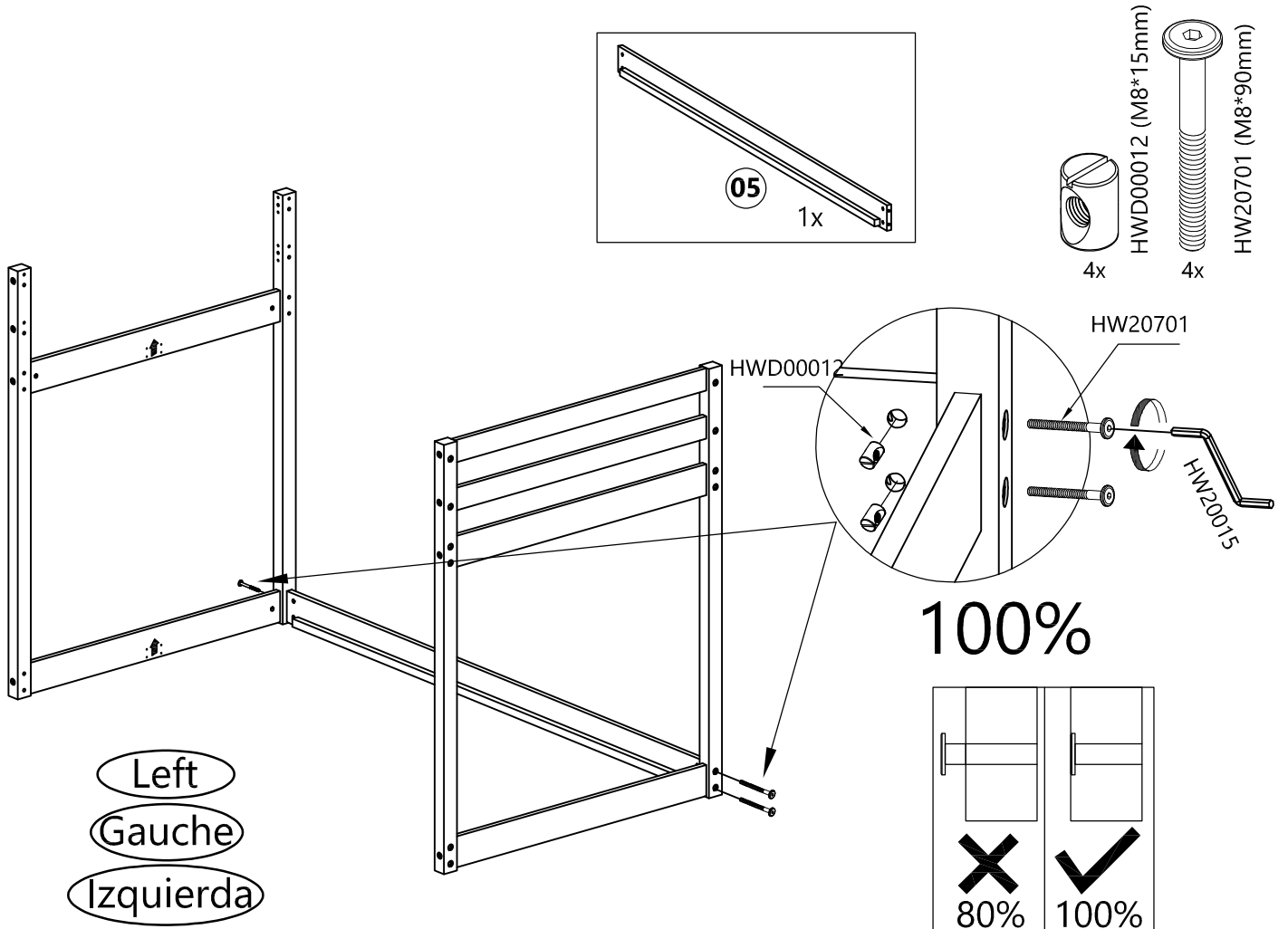

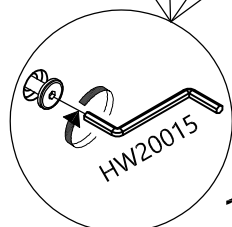
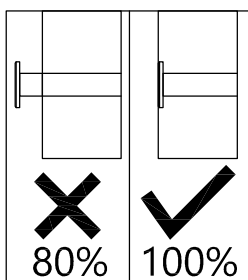
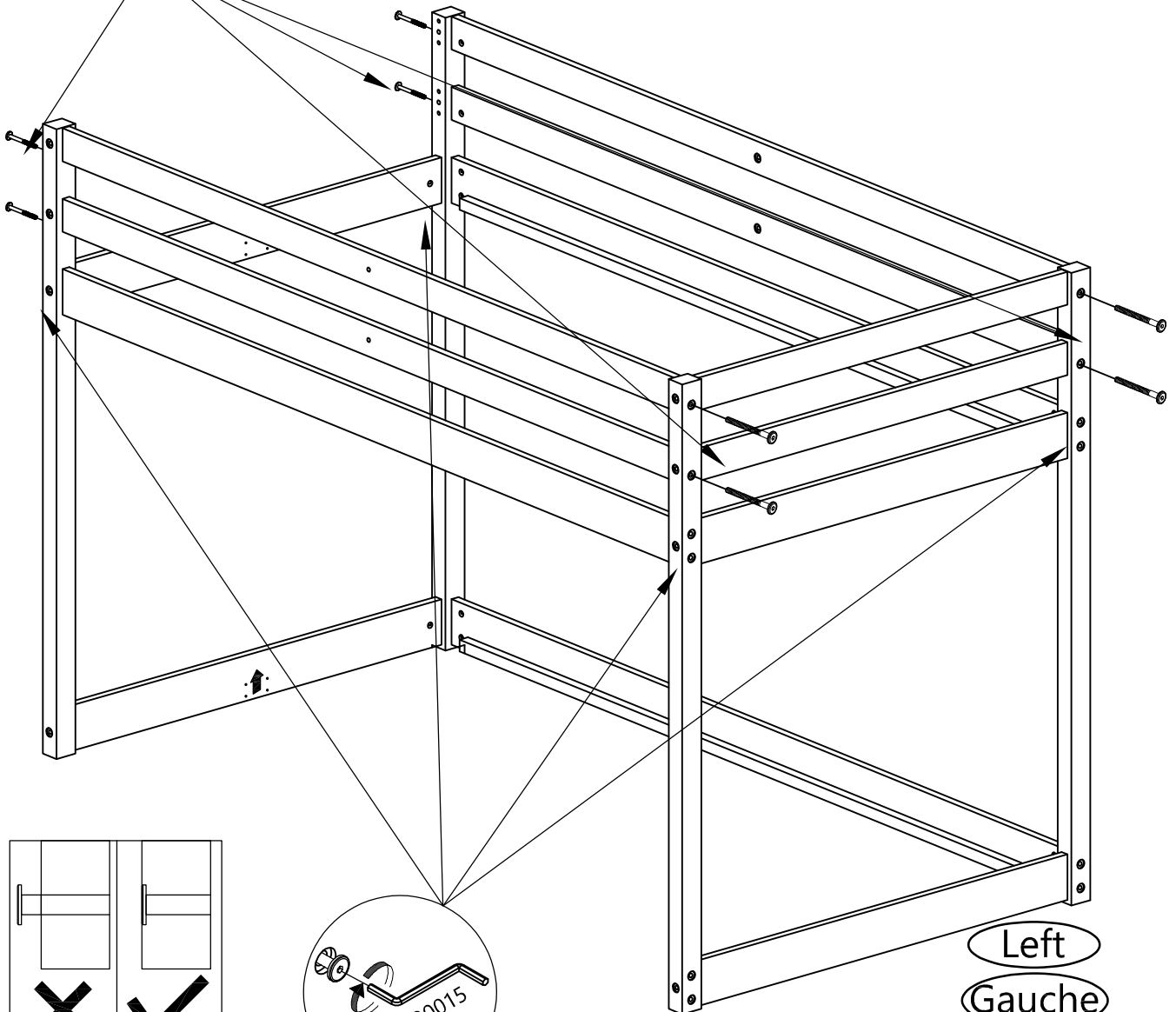
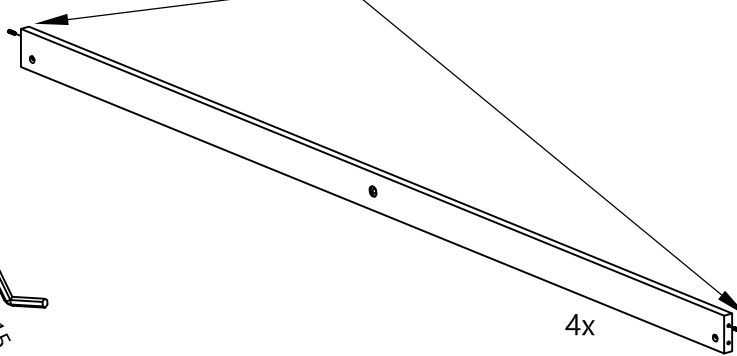
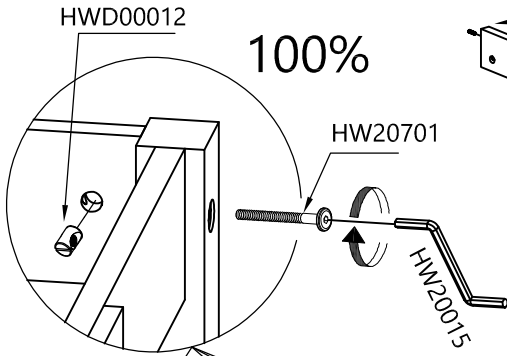
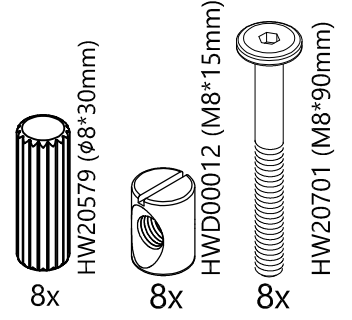
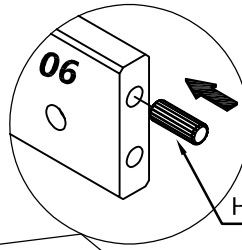
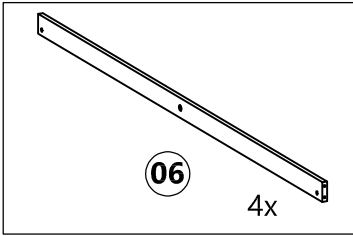

Left
Gauche
Izquierda

100%

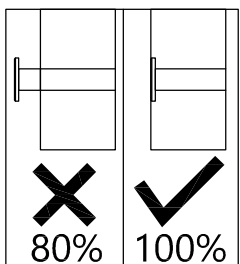
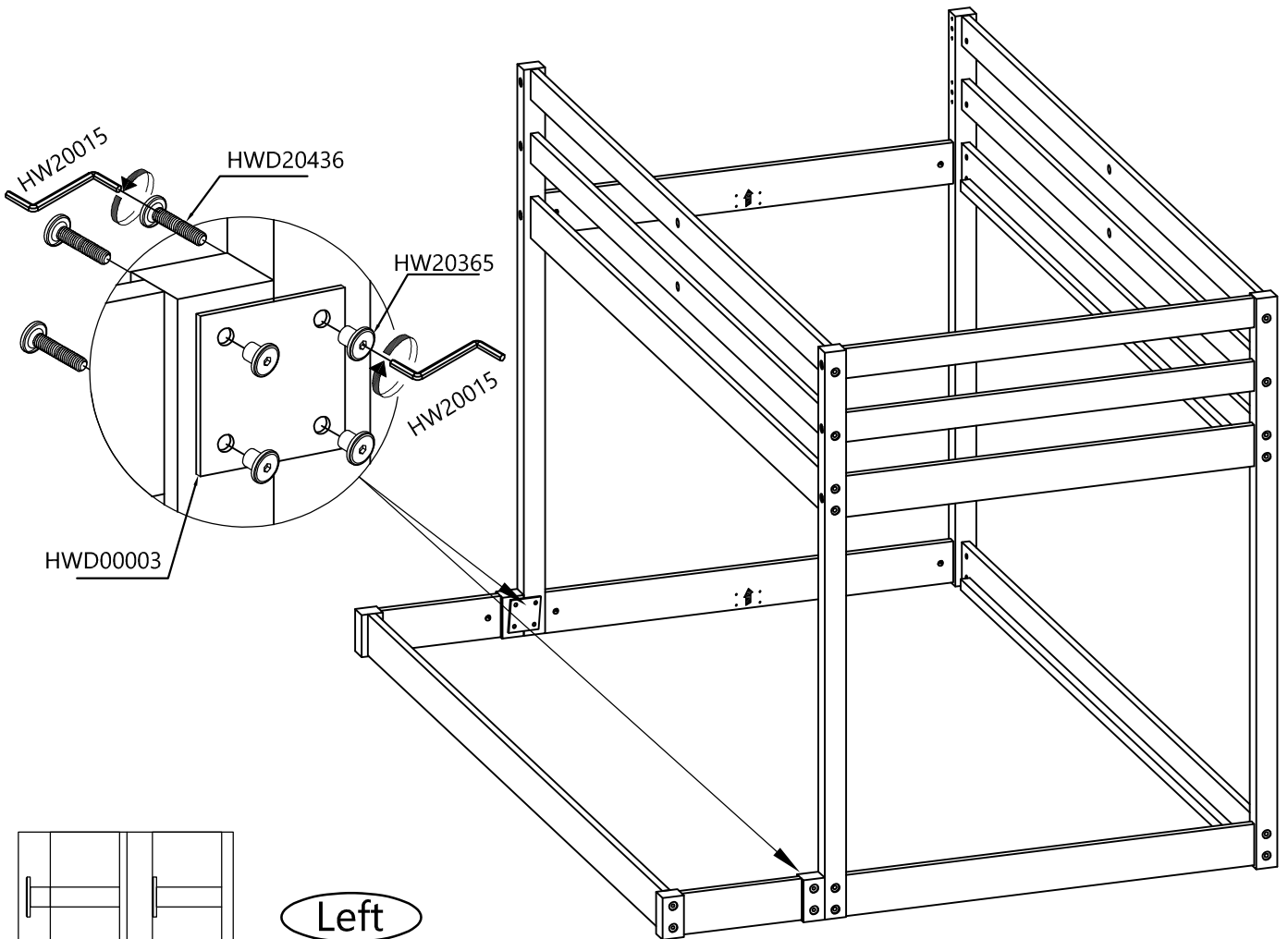
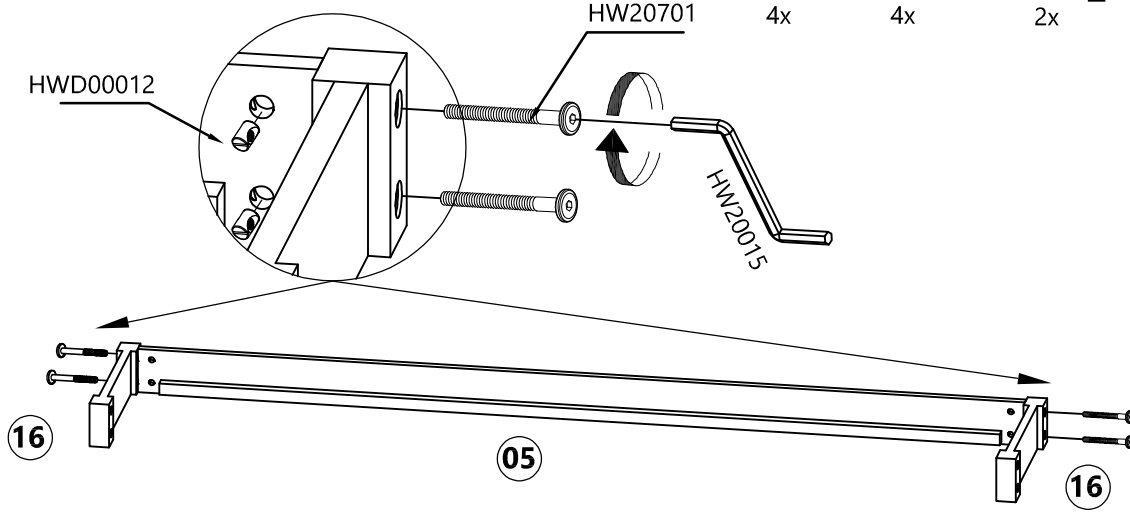
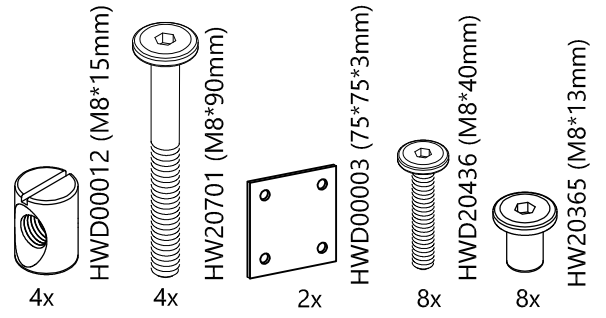
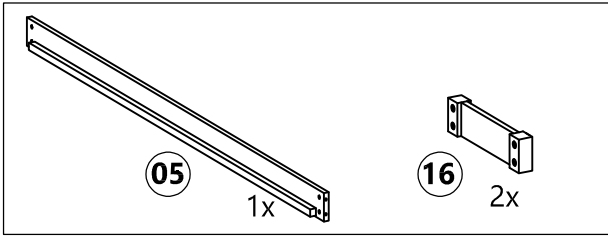

Left
Gauche
Izquierda

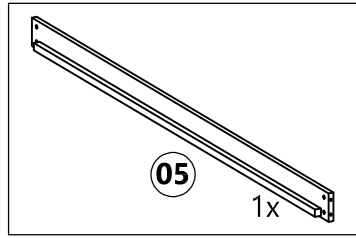
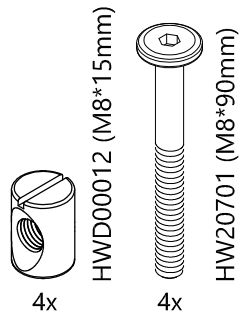

Right
Droit
Derecha

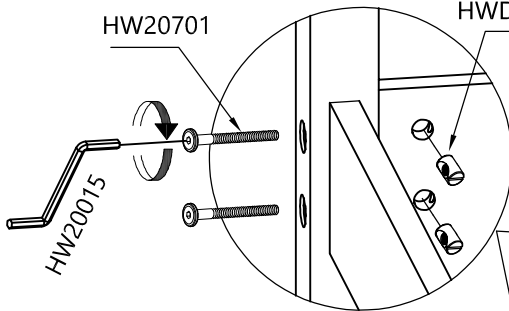

100%

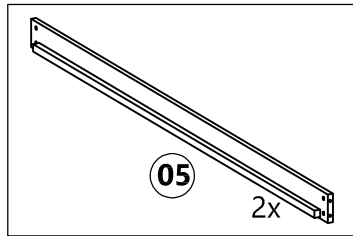
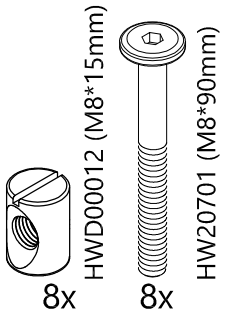
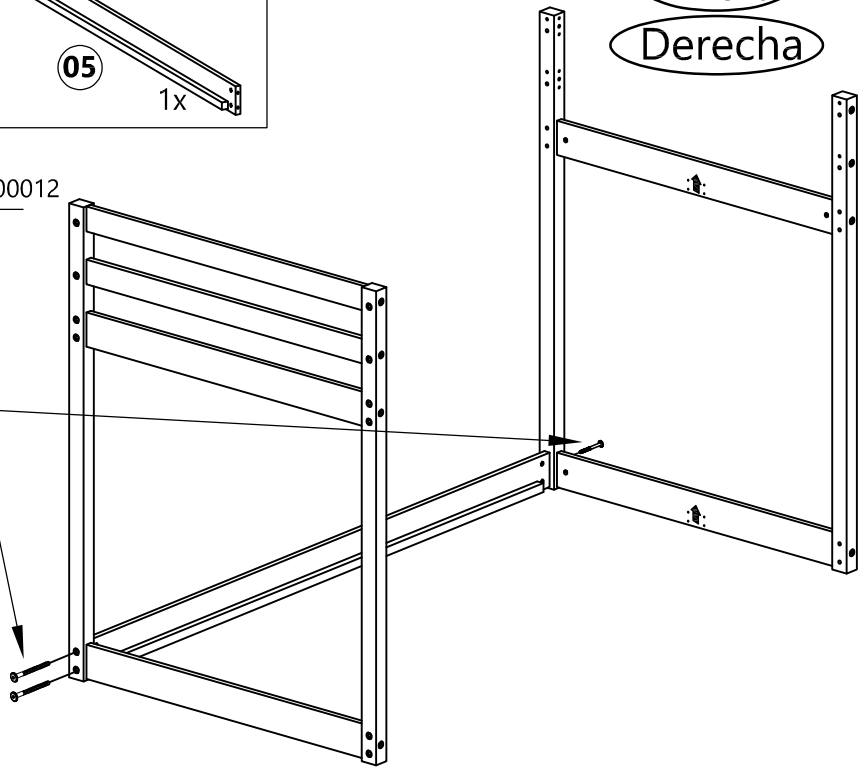
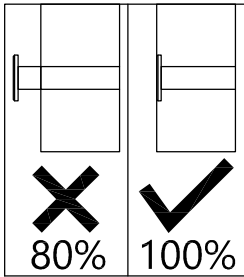

Right
Droit
Derecha

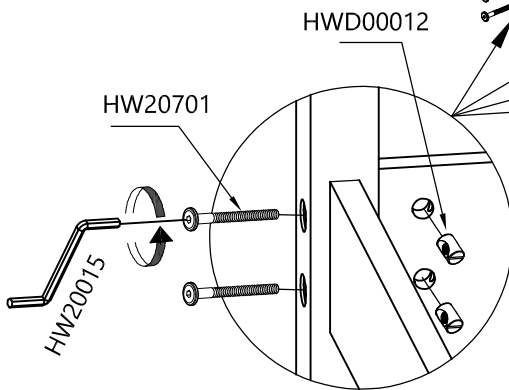

80%

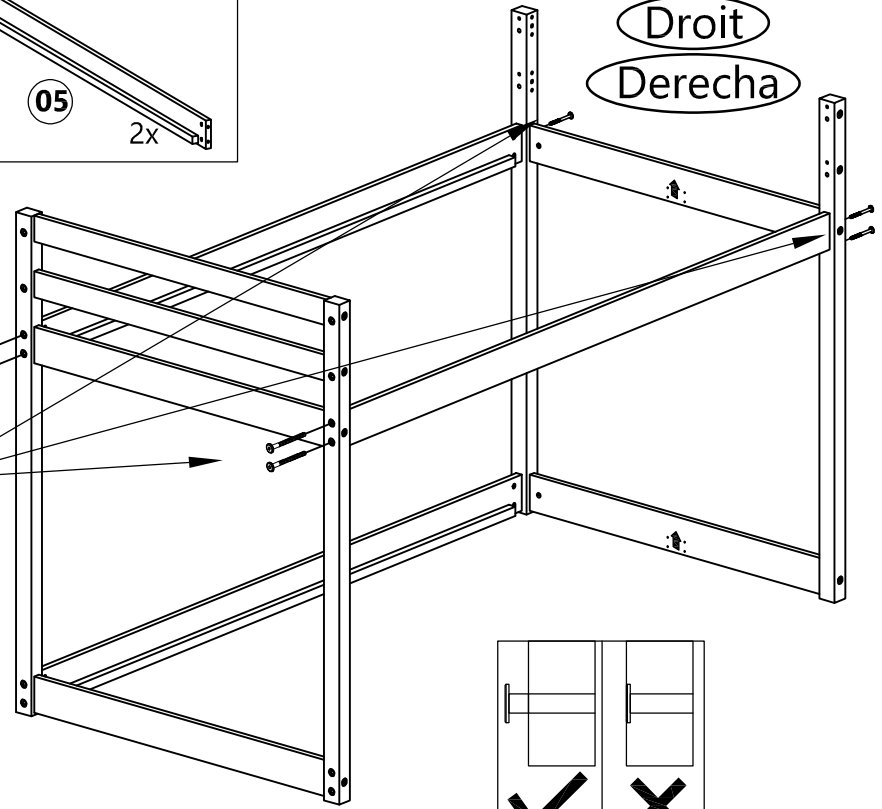
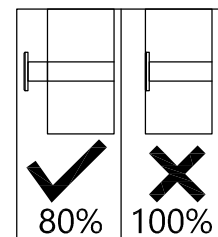

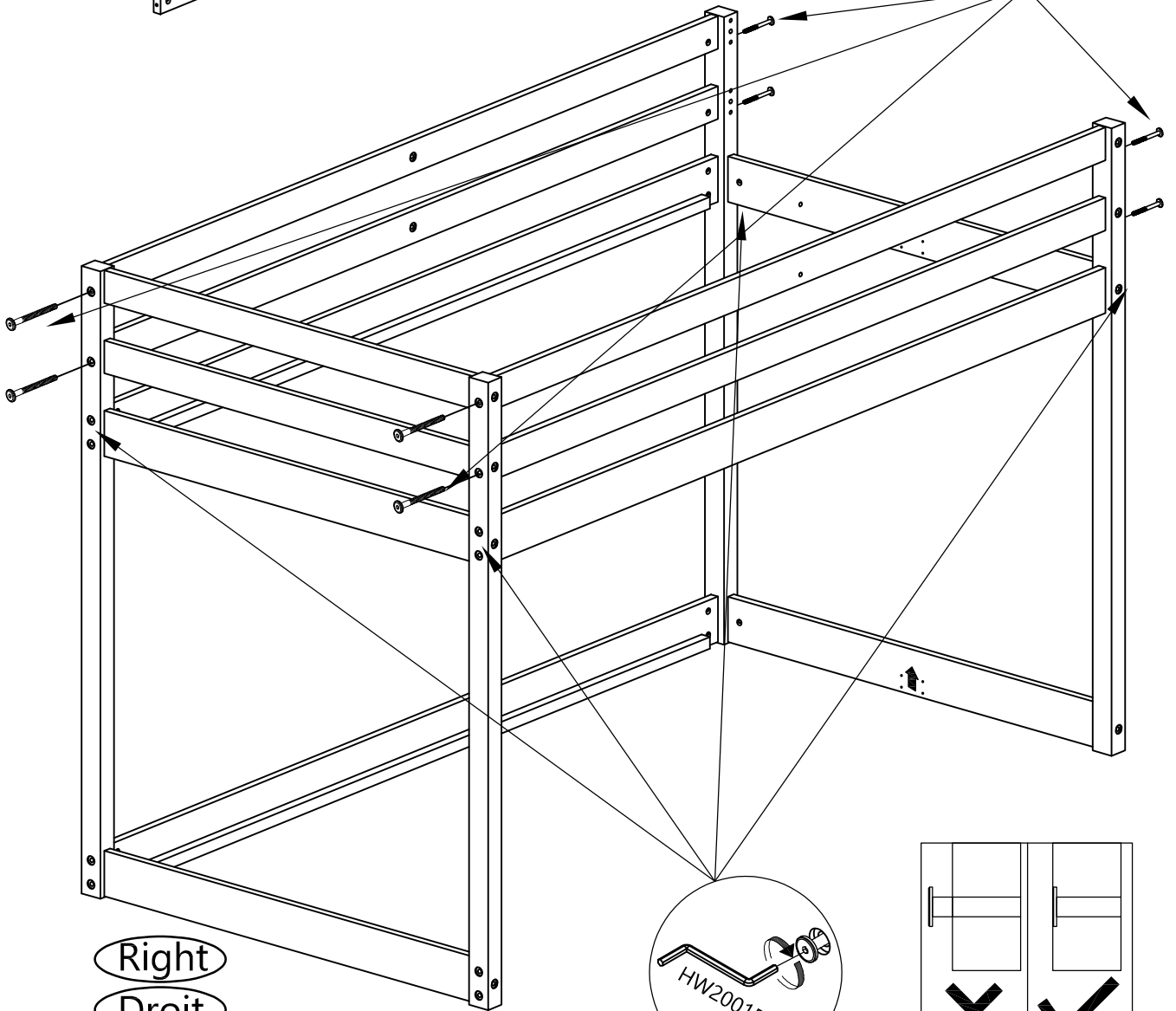
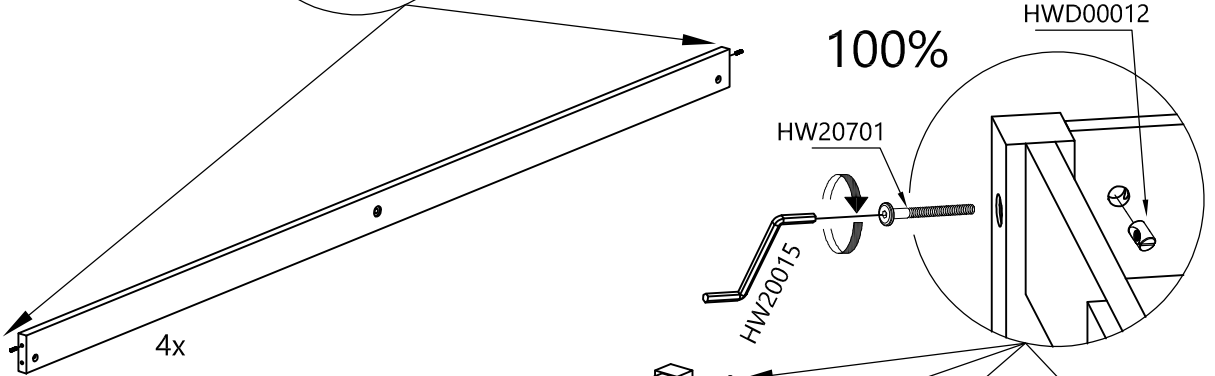
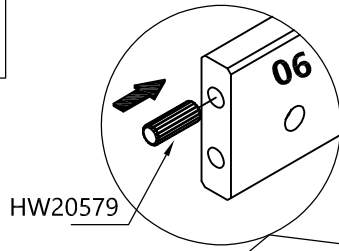
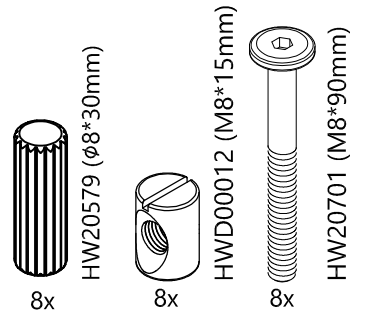
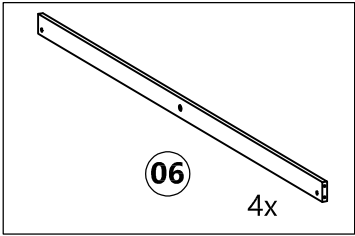

Right
Droit
Derecha

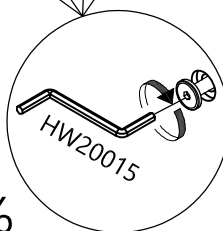

100%

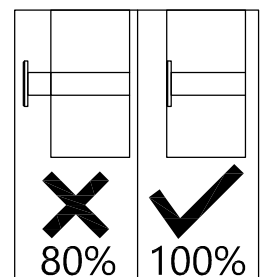

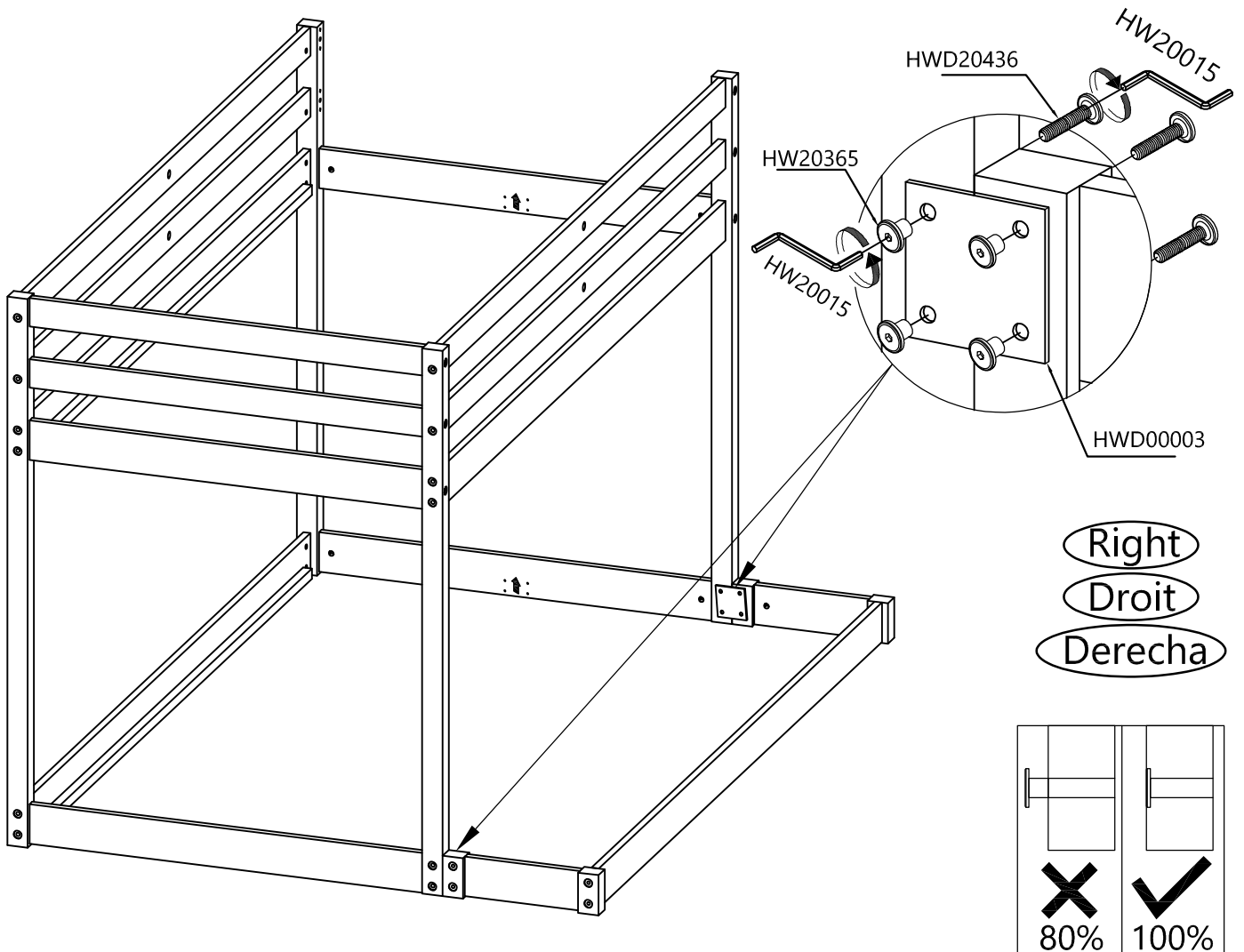
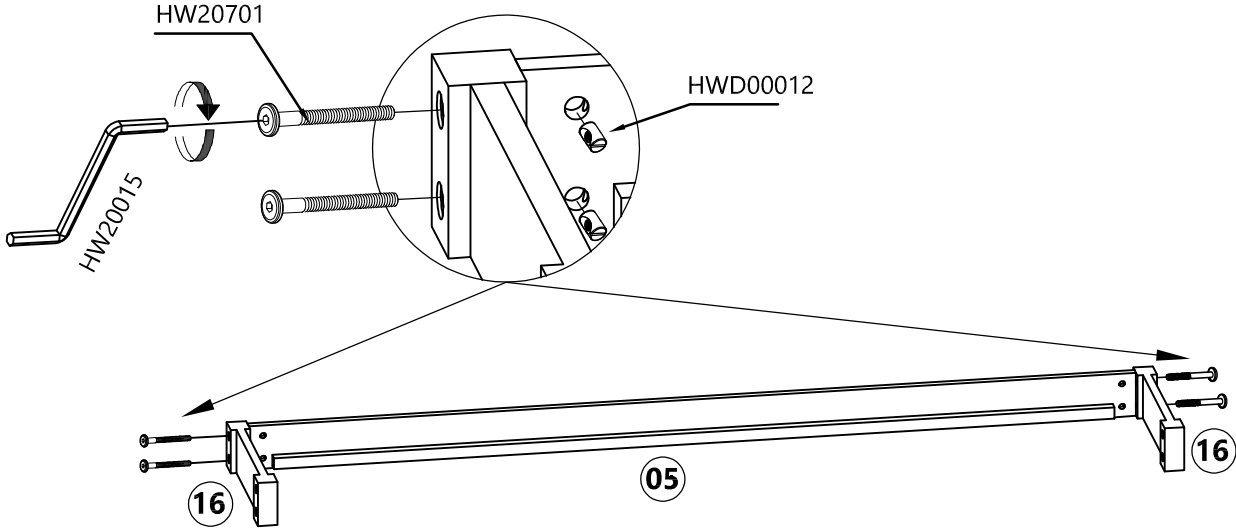
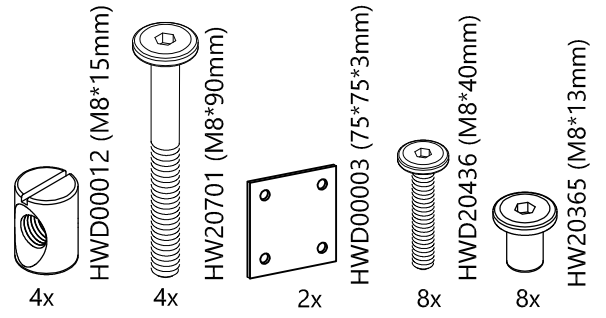
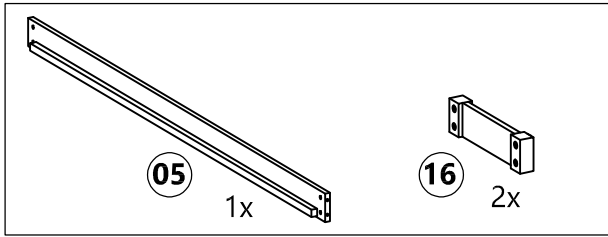

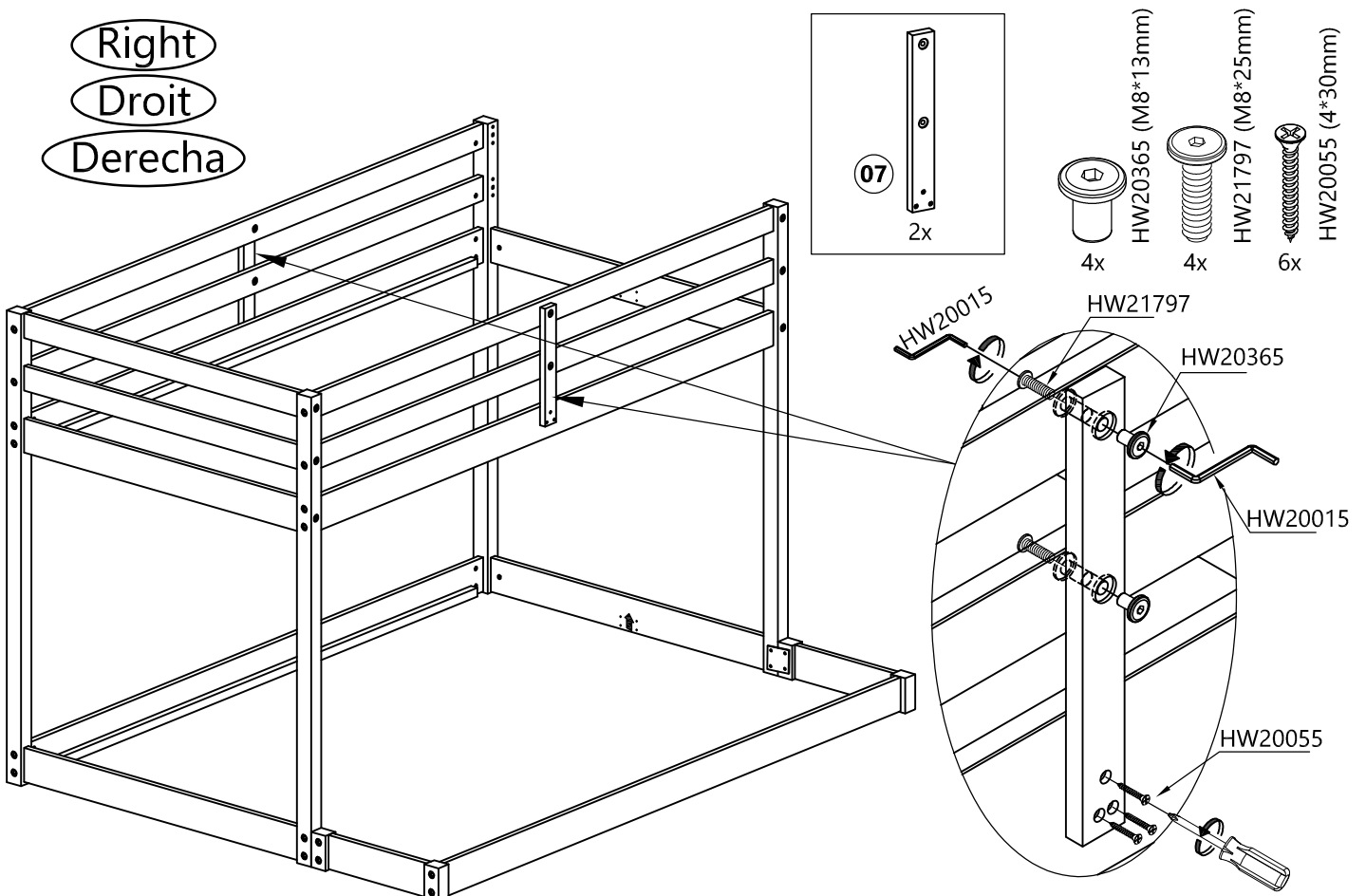
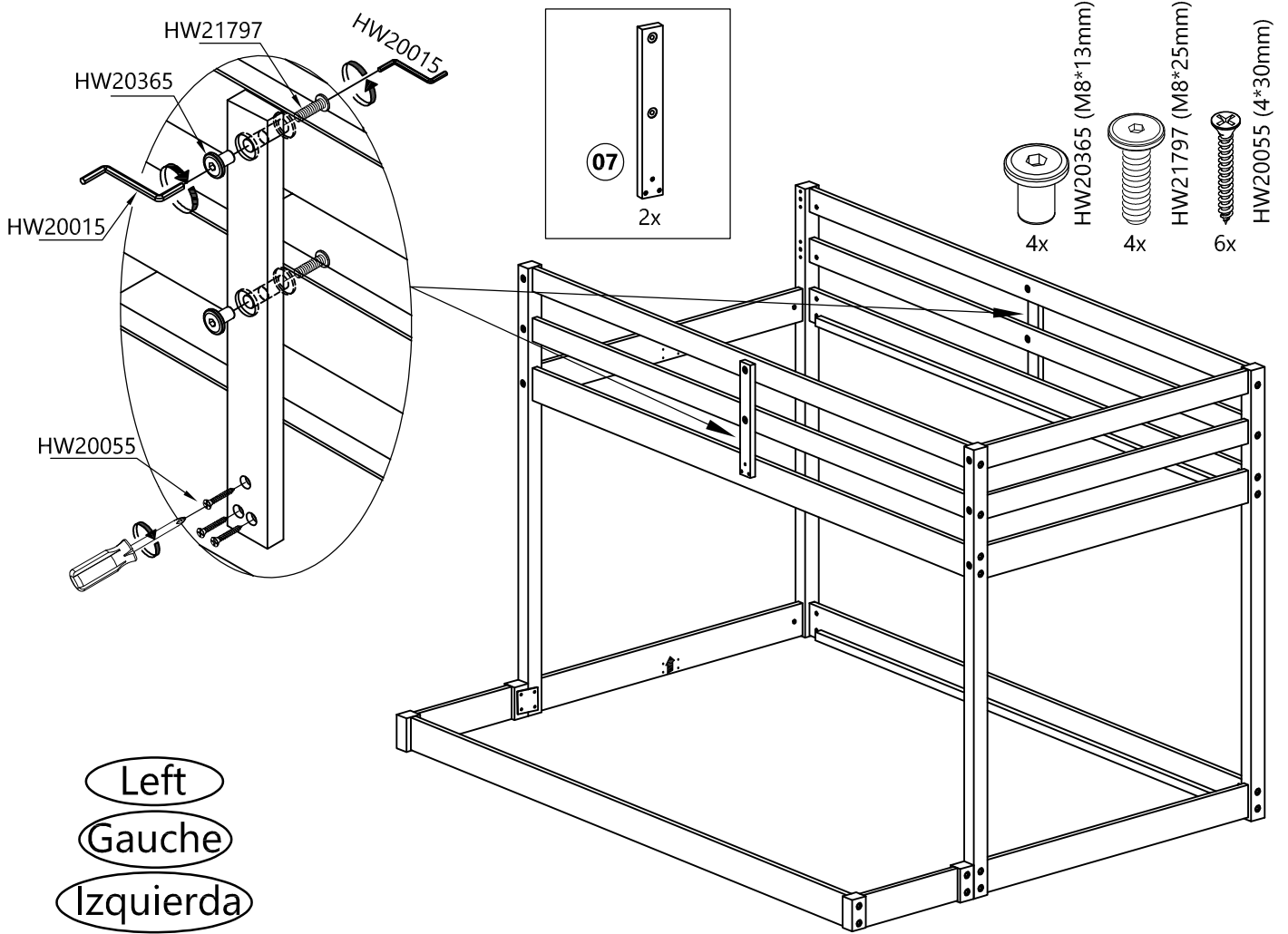

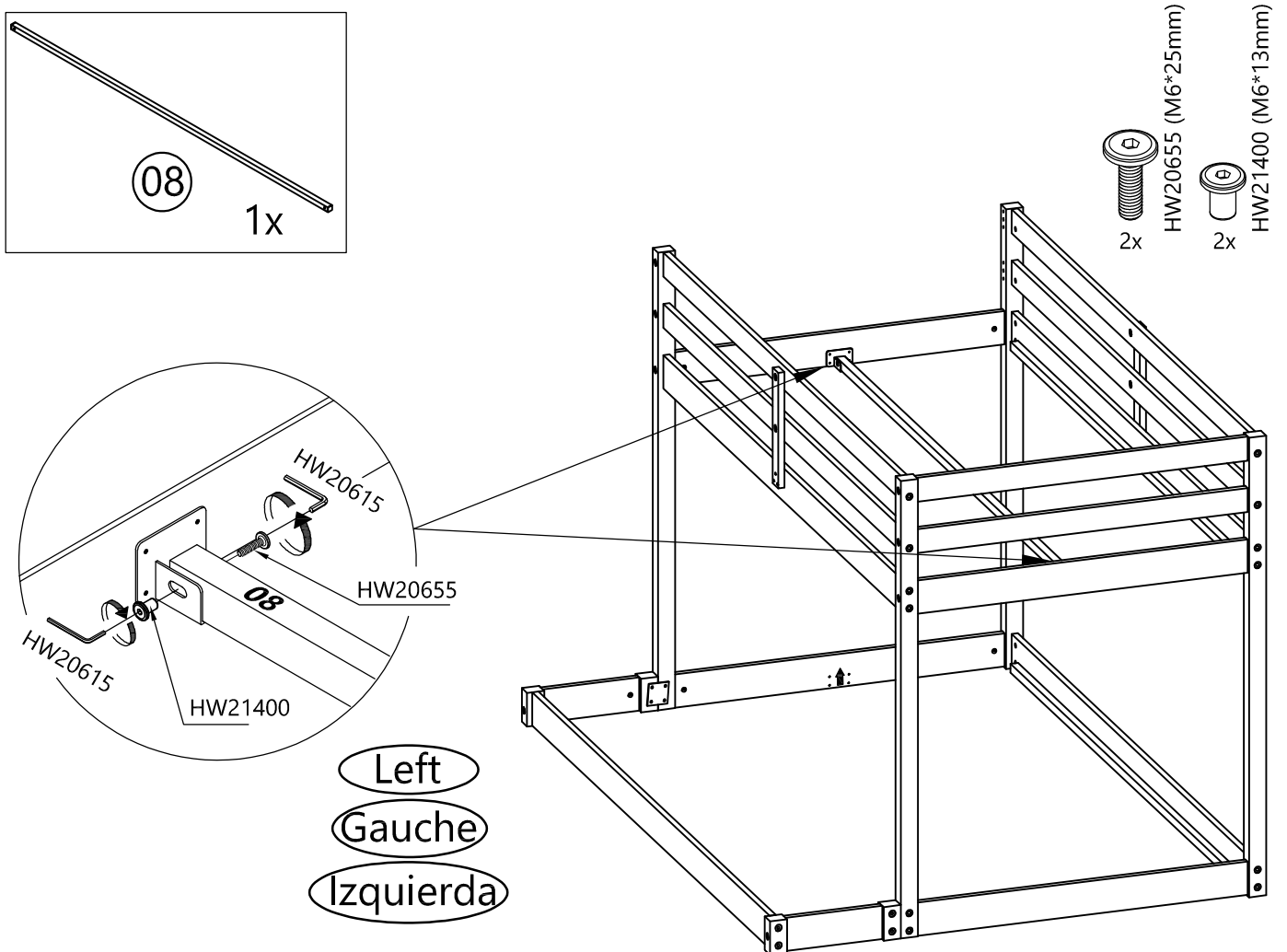
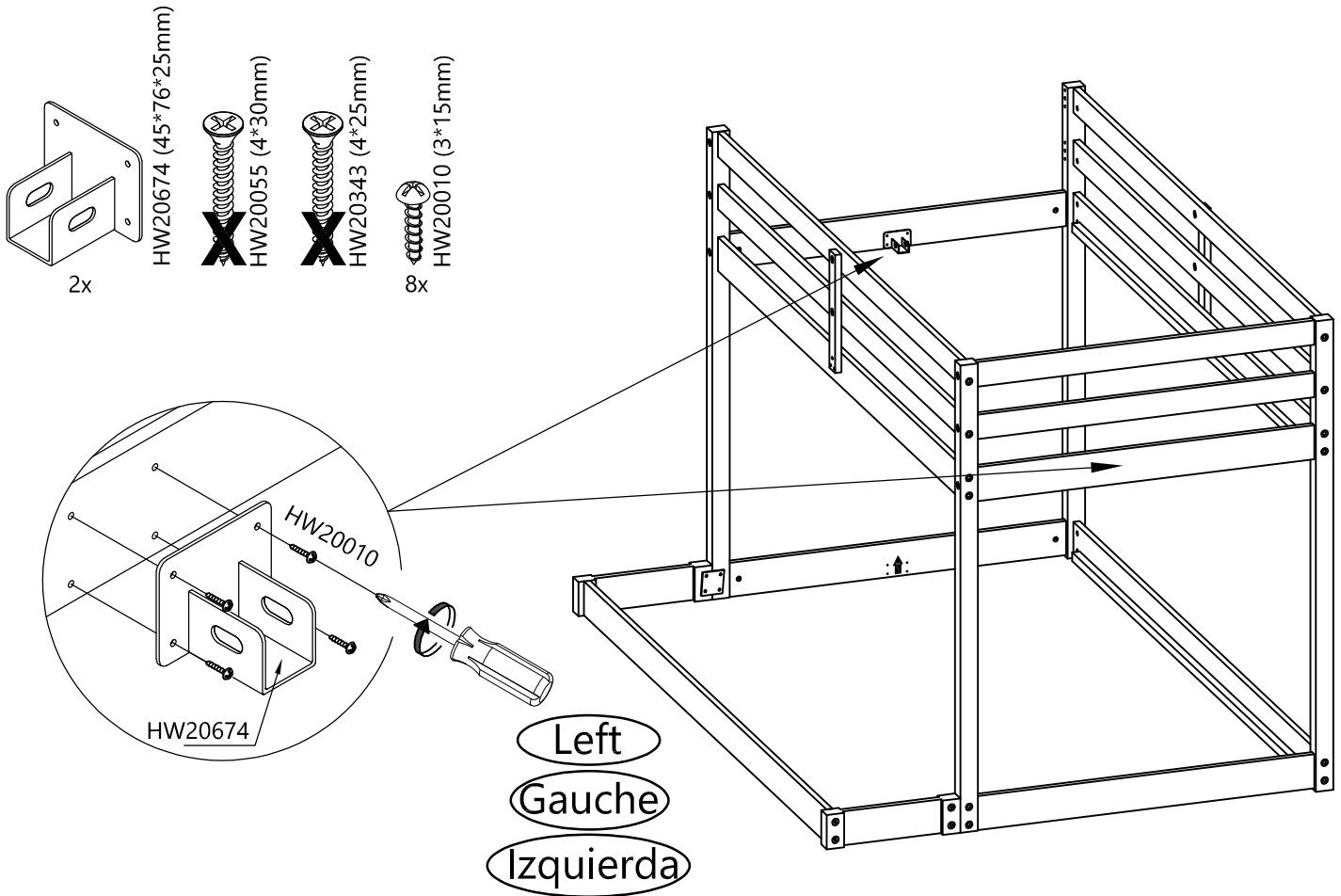

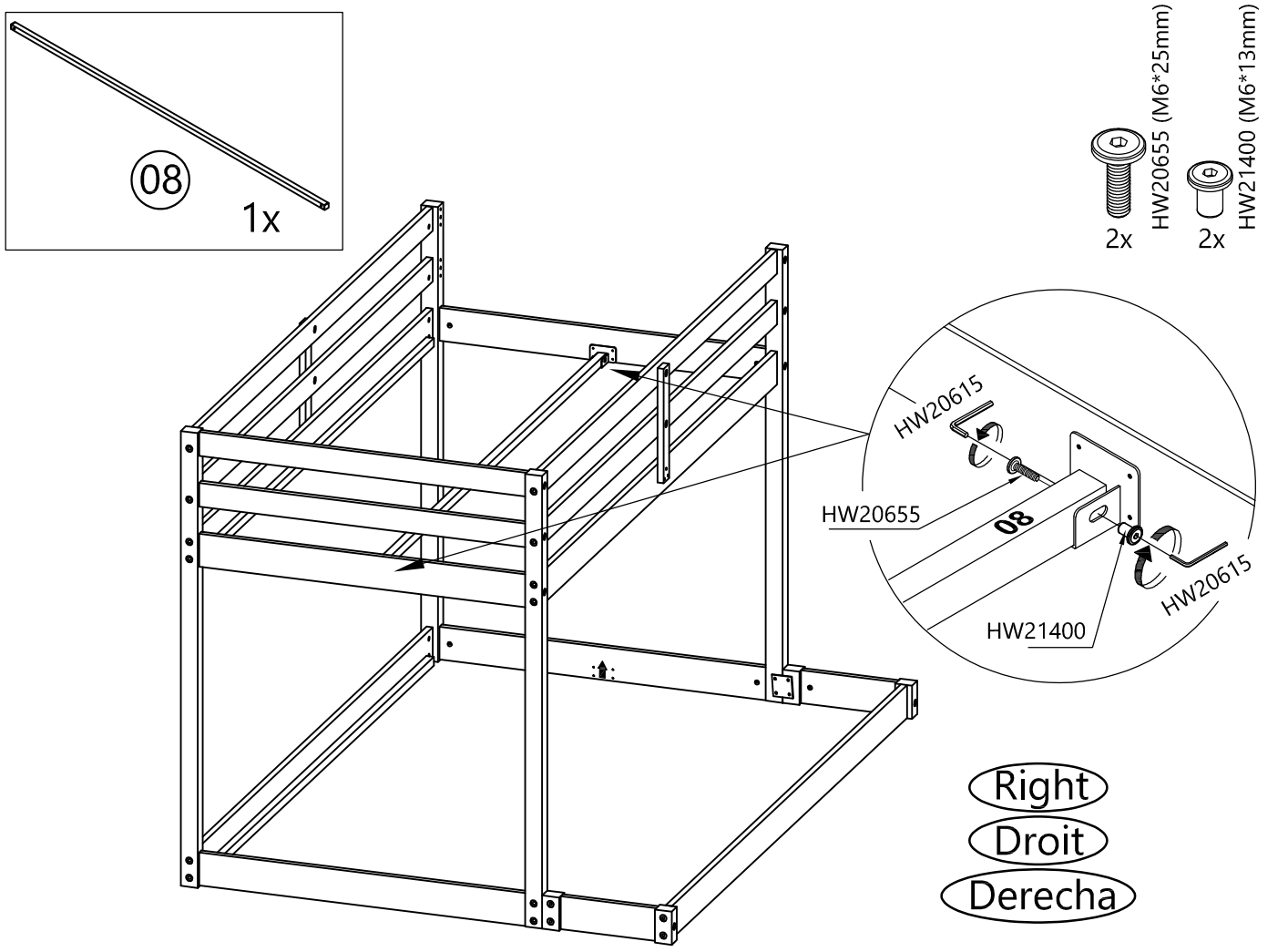
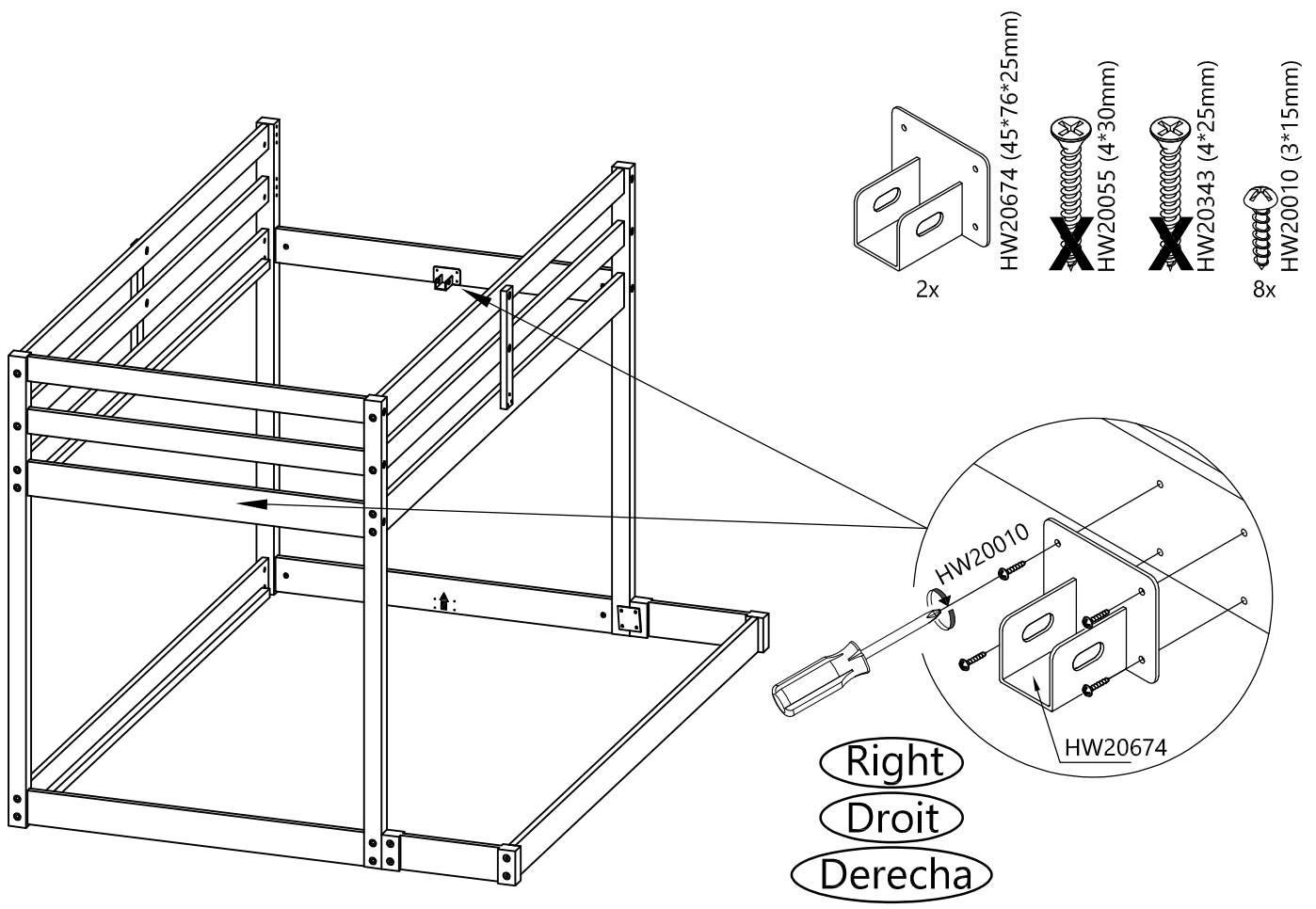

Left
Gauche
Izquierda

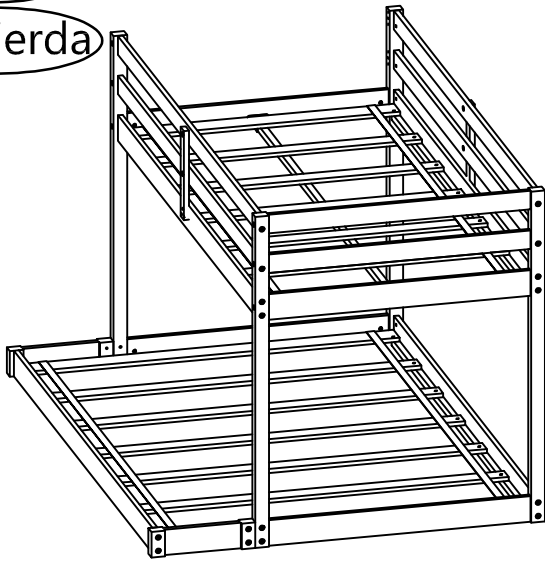

Right
Droit
Derecha

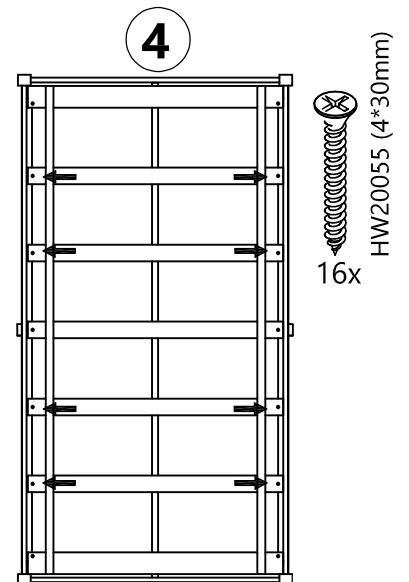
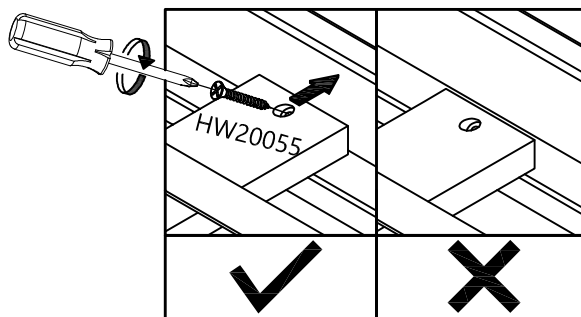
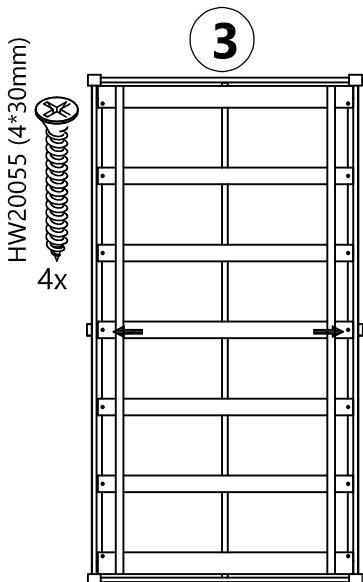
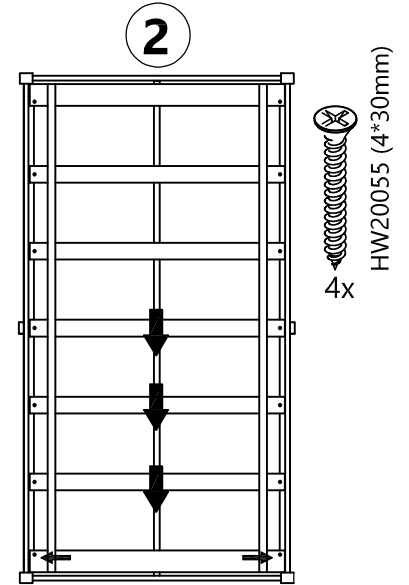
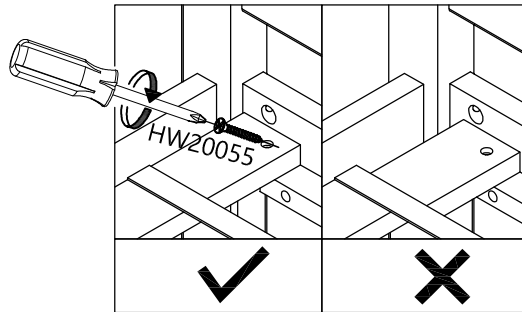
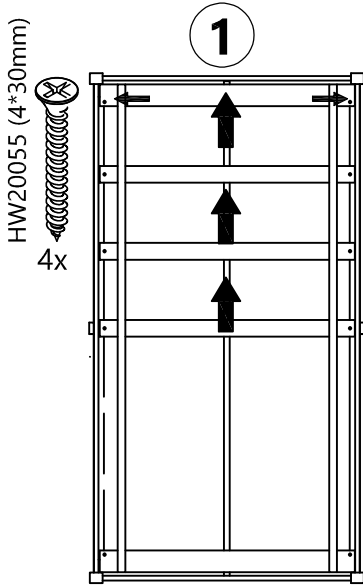
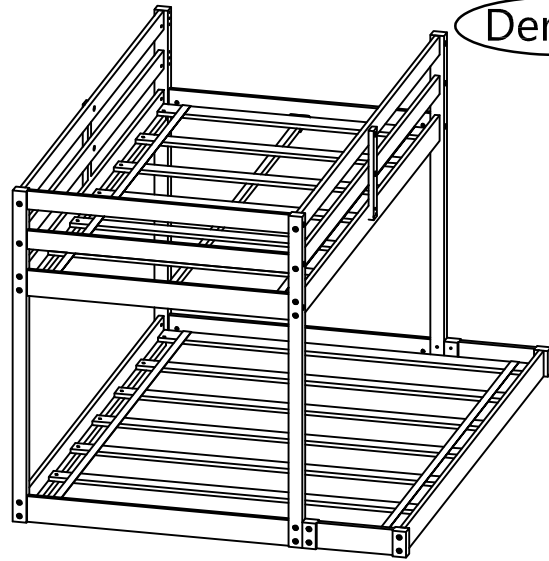

Repeat Steps 1-4 for Each Bed
Suivez les étapes 1 à 4 pour tous les lits
Siga los pasos 1 a 4 en todos los modelos de camas

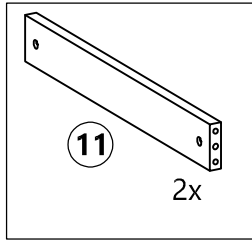

HW20579 (Ø8*30mm)

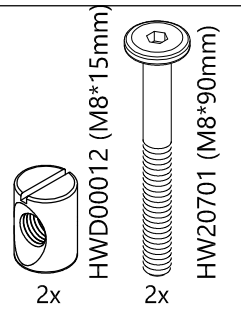
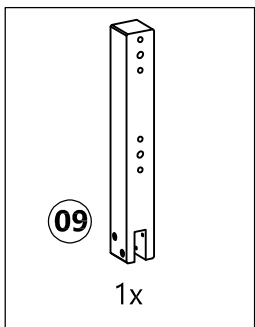
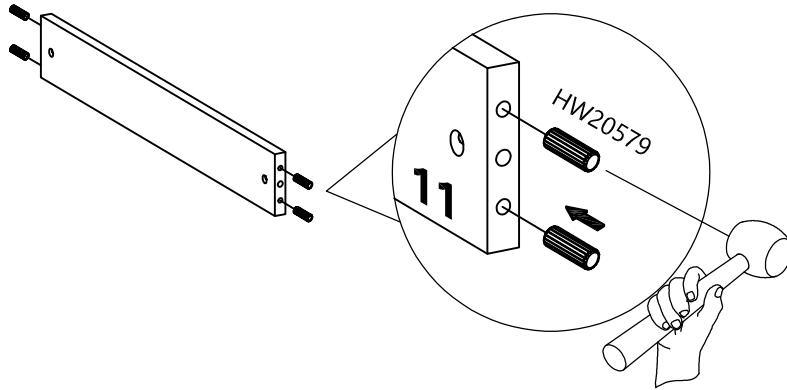

HWD00012 (M8*15mm)

HW20701 (M8*90mm)

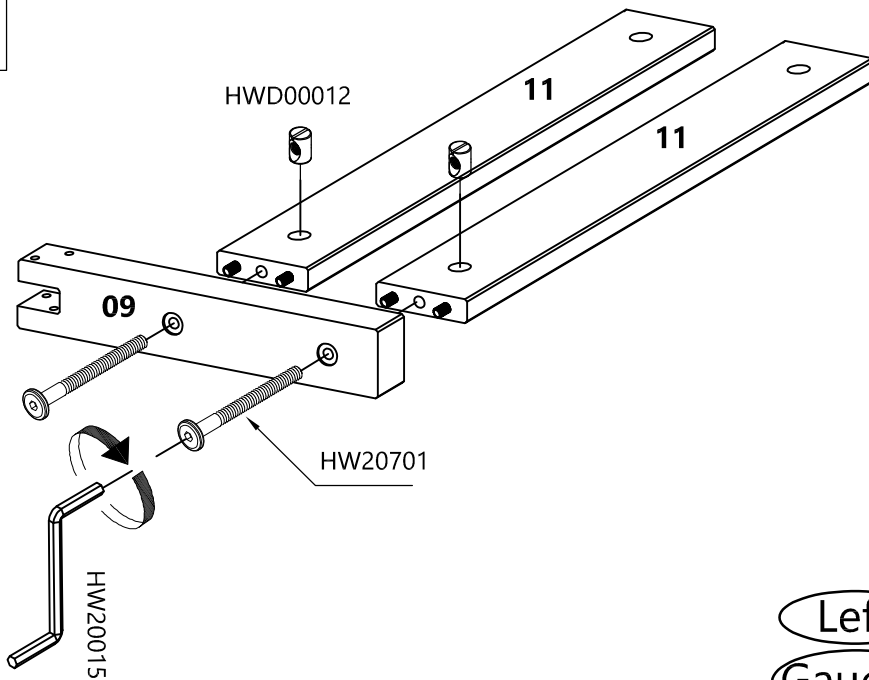

Left
Gauche
Izquierda

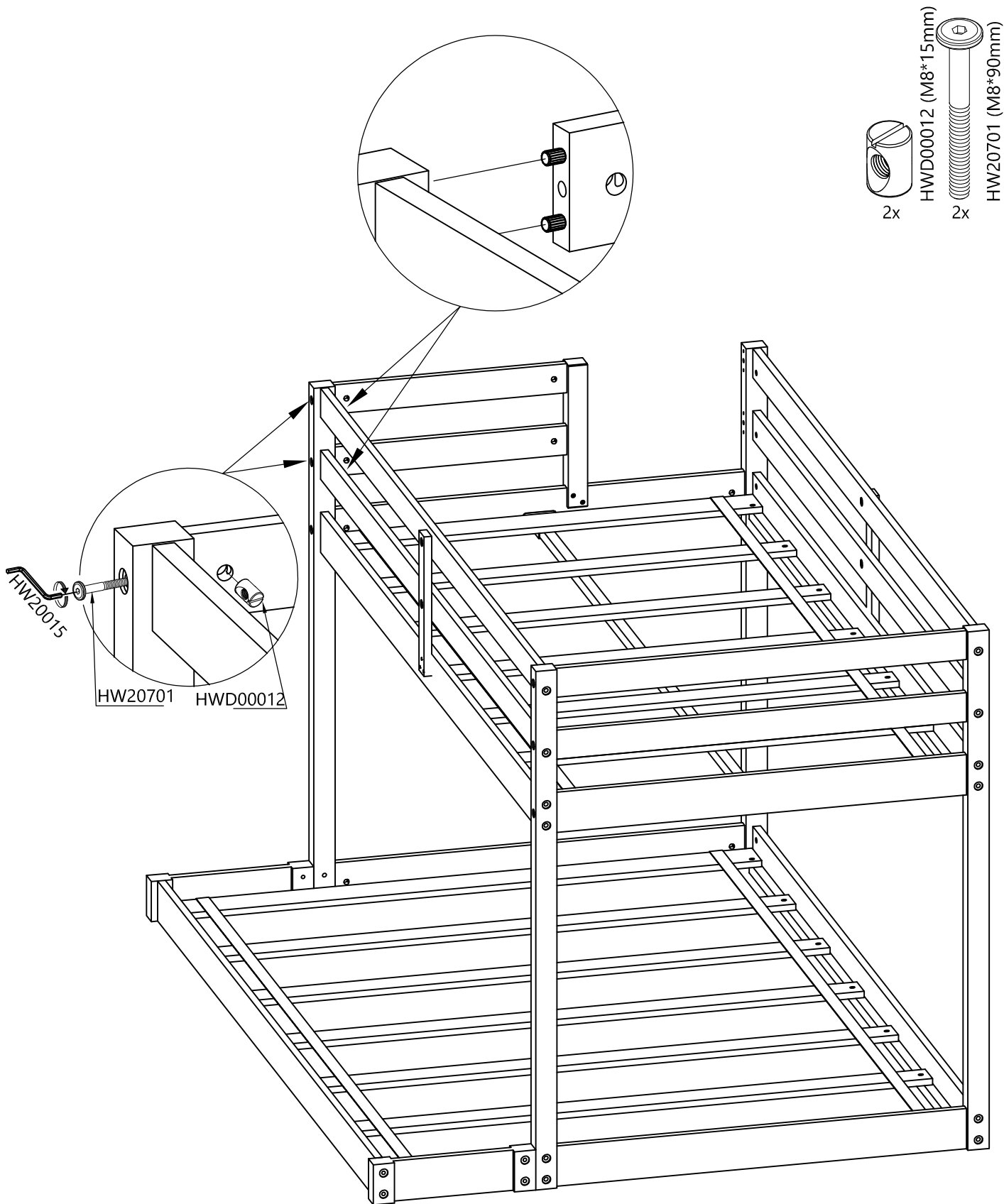

Left

Gauche

Izquierda

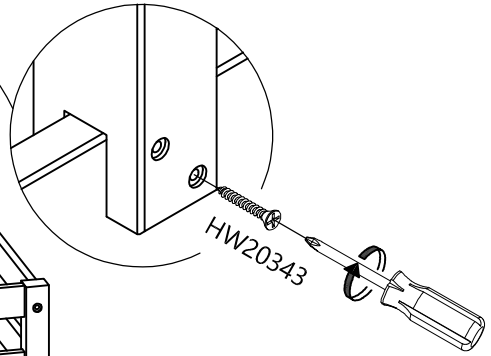
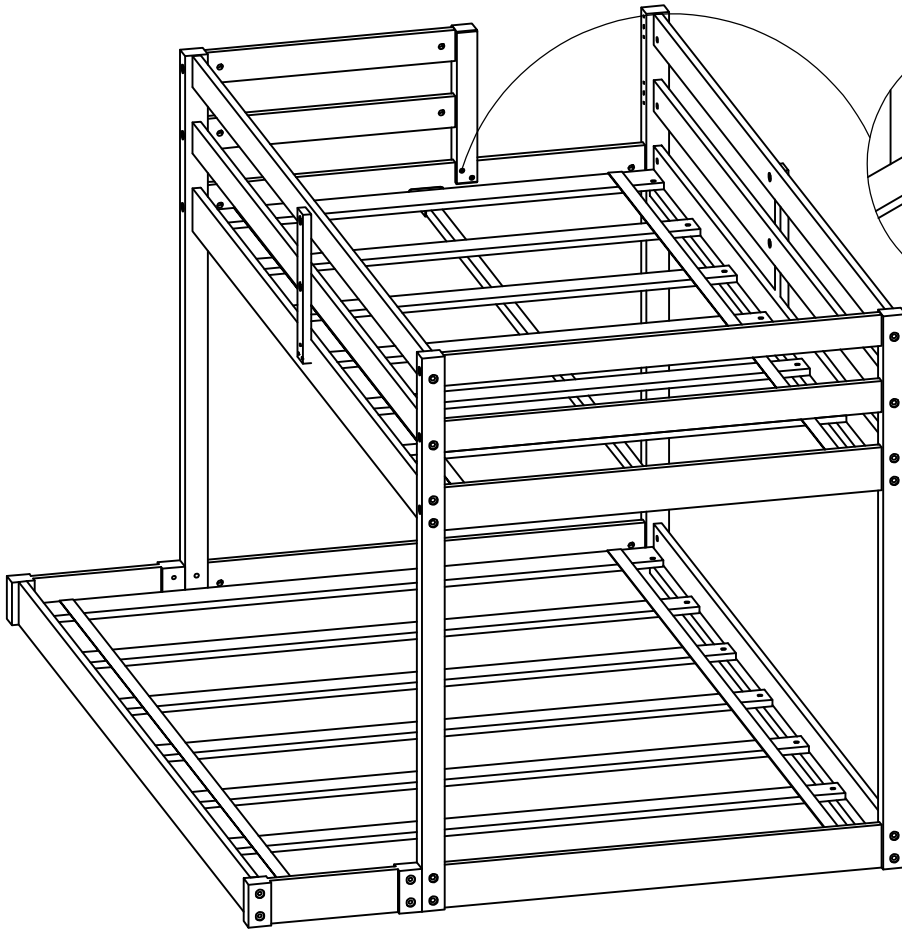

2x

HW20343 (4*25mm)

Left
Gauche
Izquierda

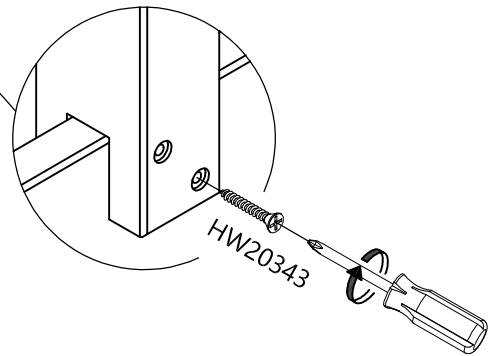
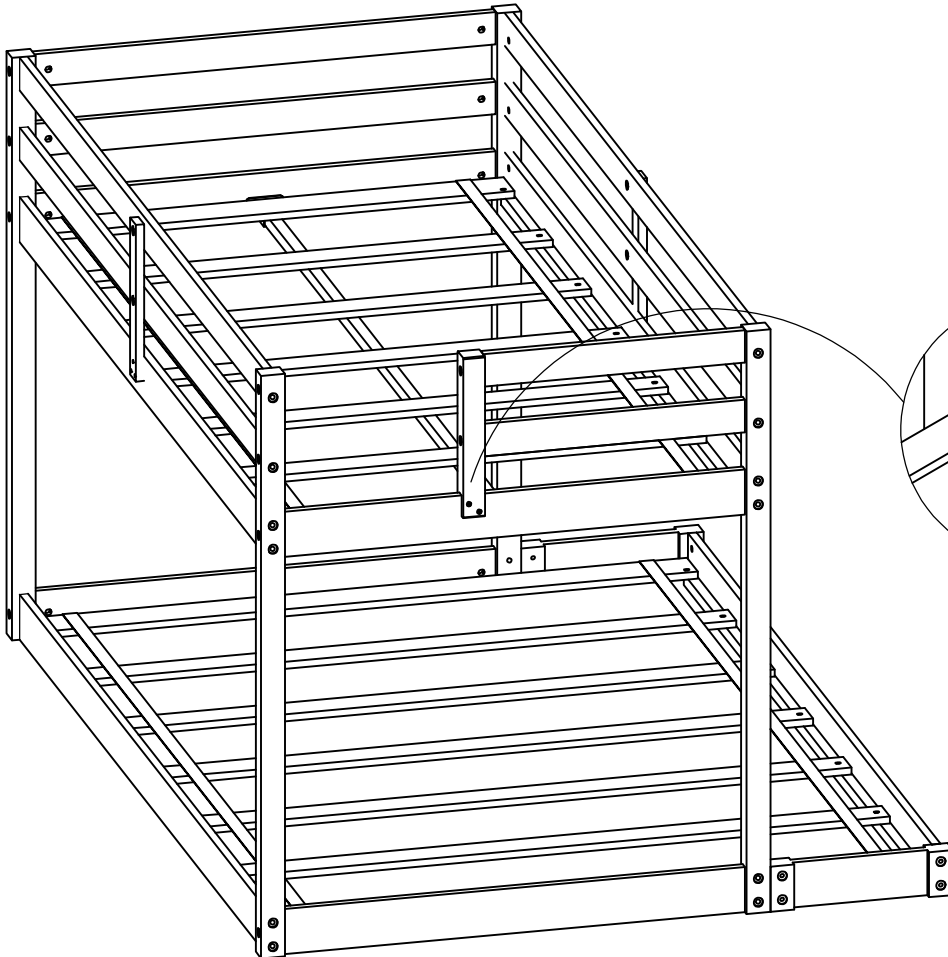

2x

HW20343 (4*25mm)

Left
Gauche
Izquierda

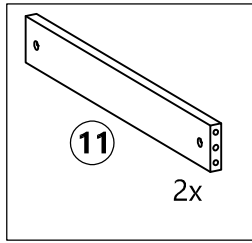

HW20579 (Ø8*30mm)

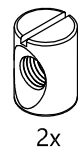
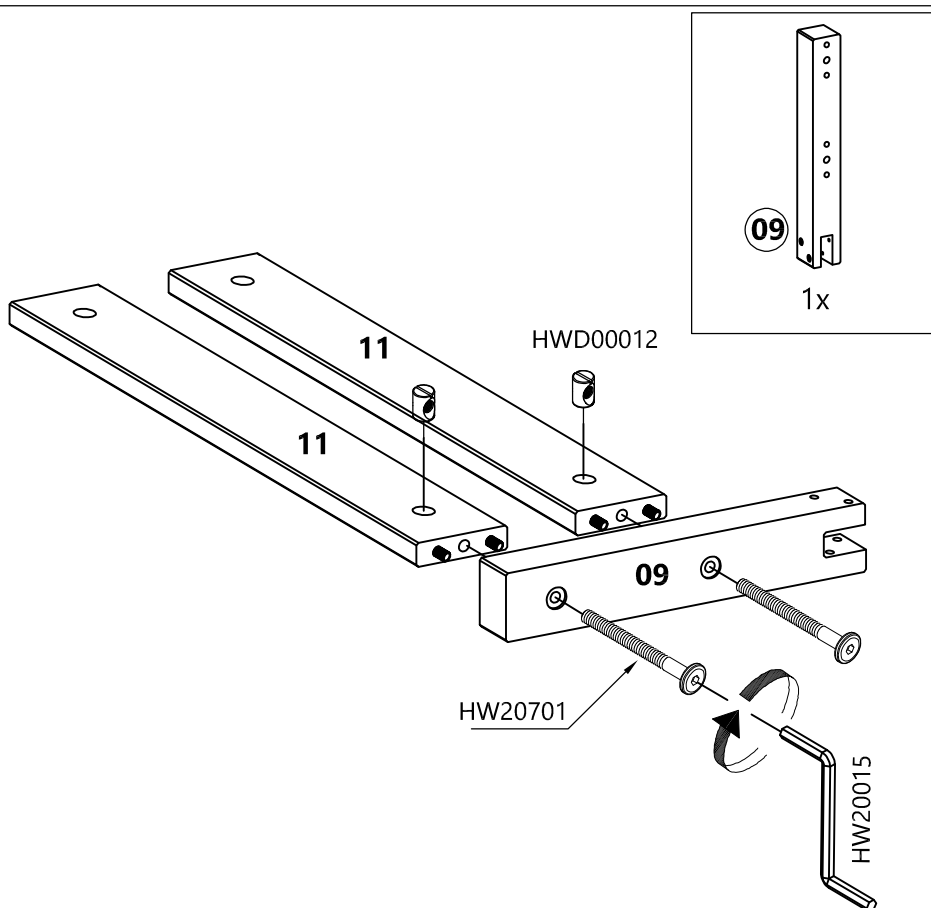
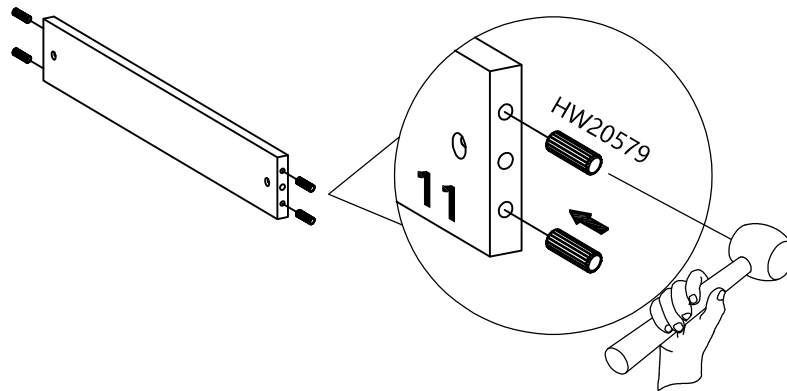

HWD00012 (M8*15mm)

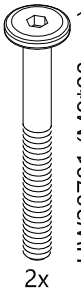

HW20701 (M8*90mm)

Right
Droit
Derecha

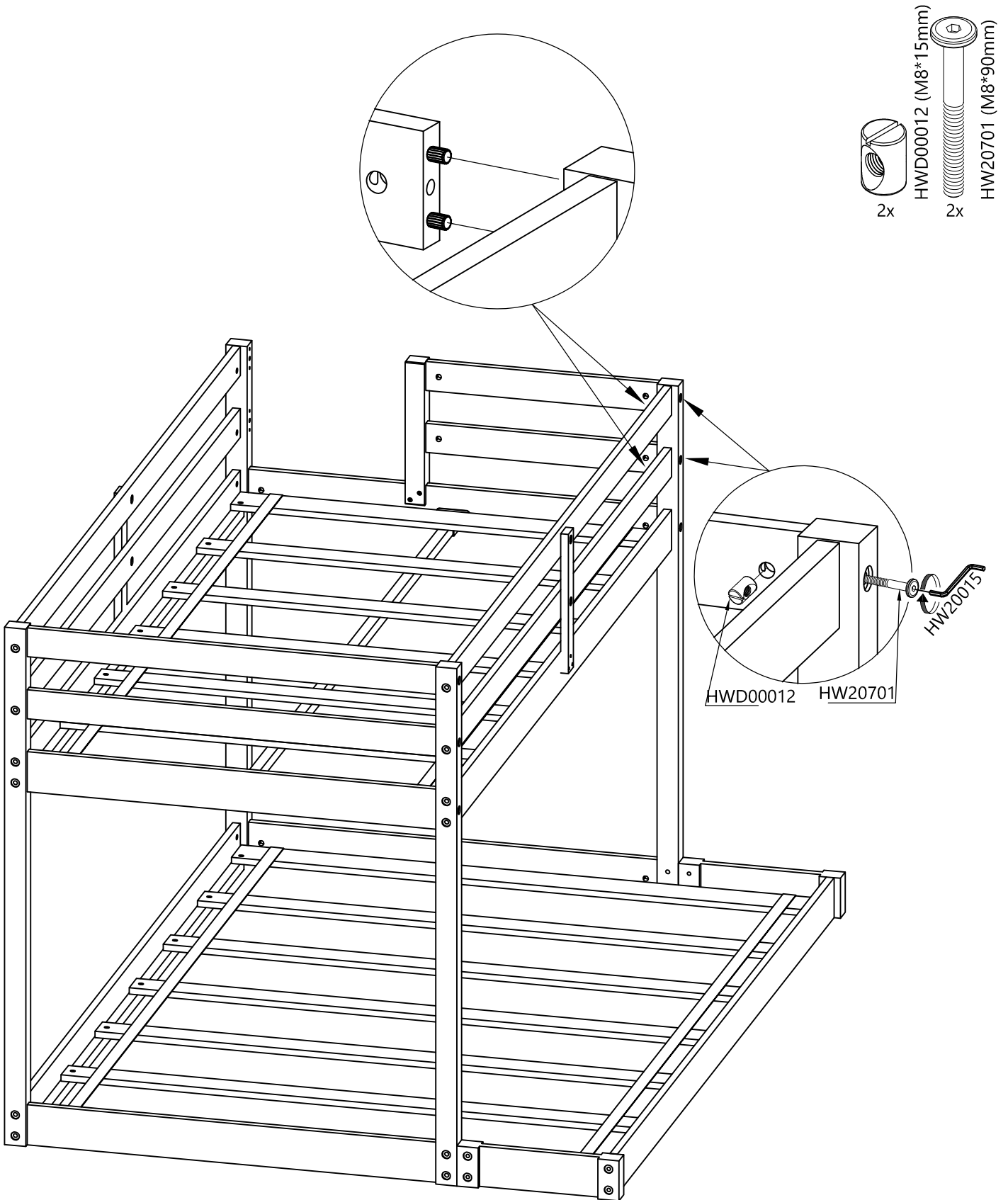

Right
Droit
Derecha

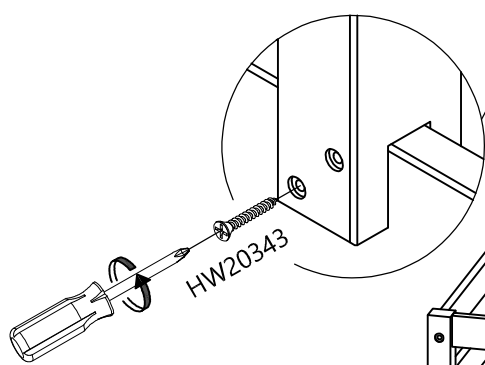

2x HW20343 (4*25mm)

Right
Droit
Derecha

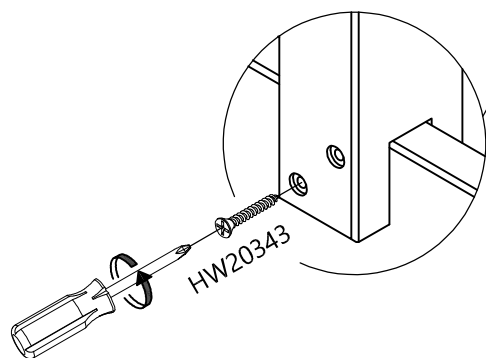
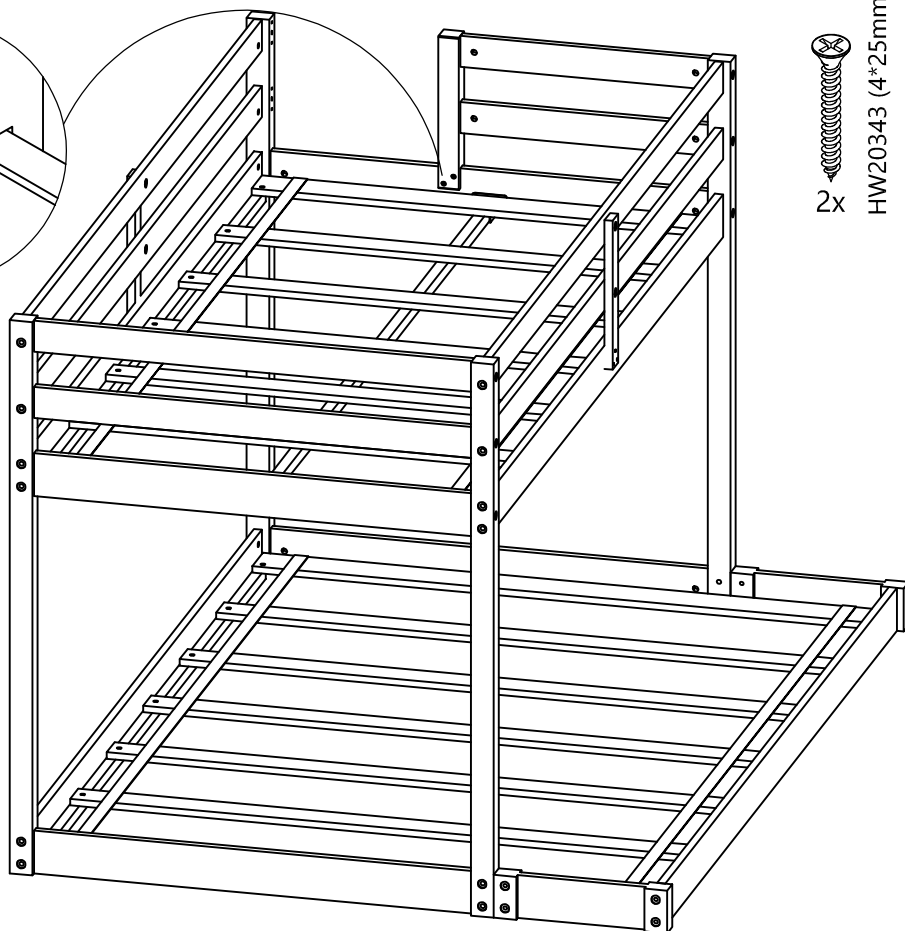

2x HW20343 (4*25mm)

Right
Droit
Derecha

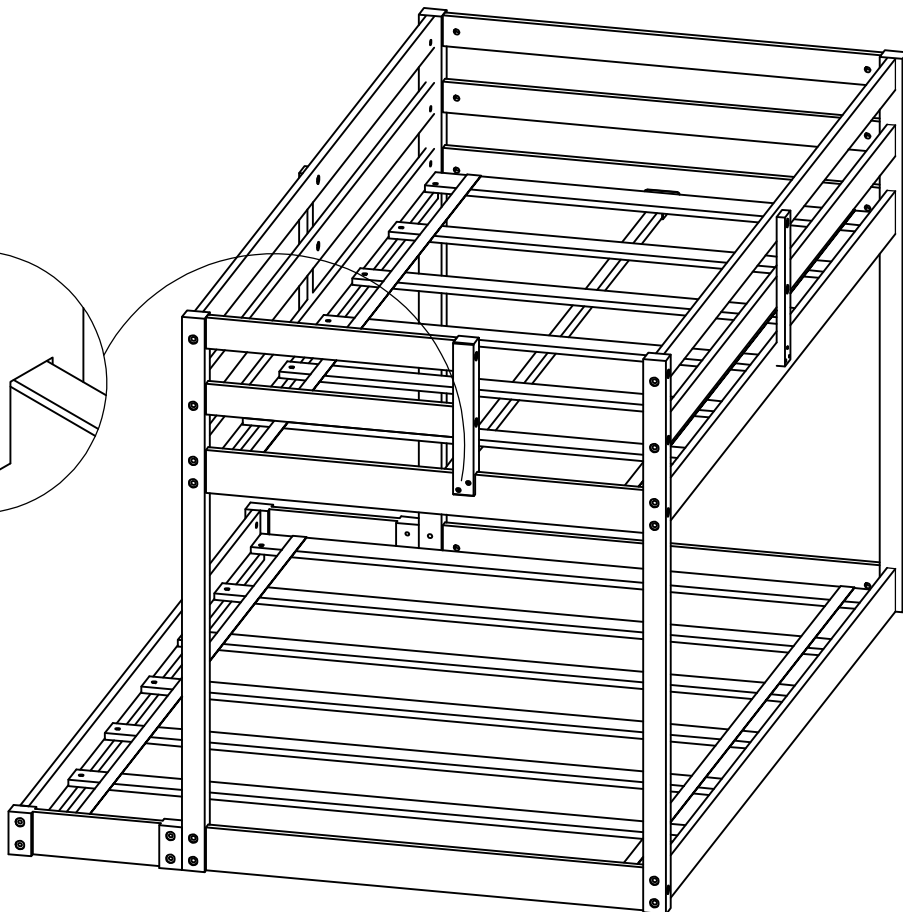

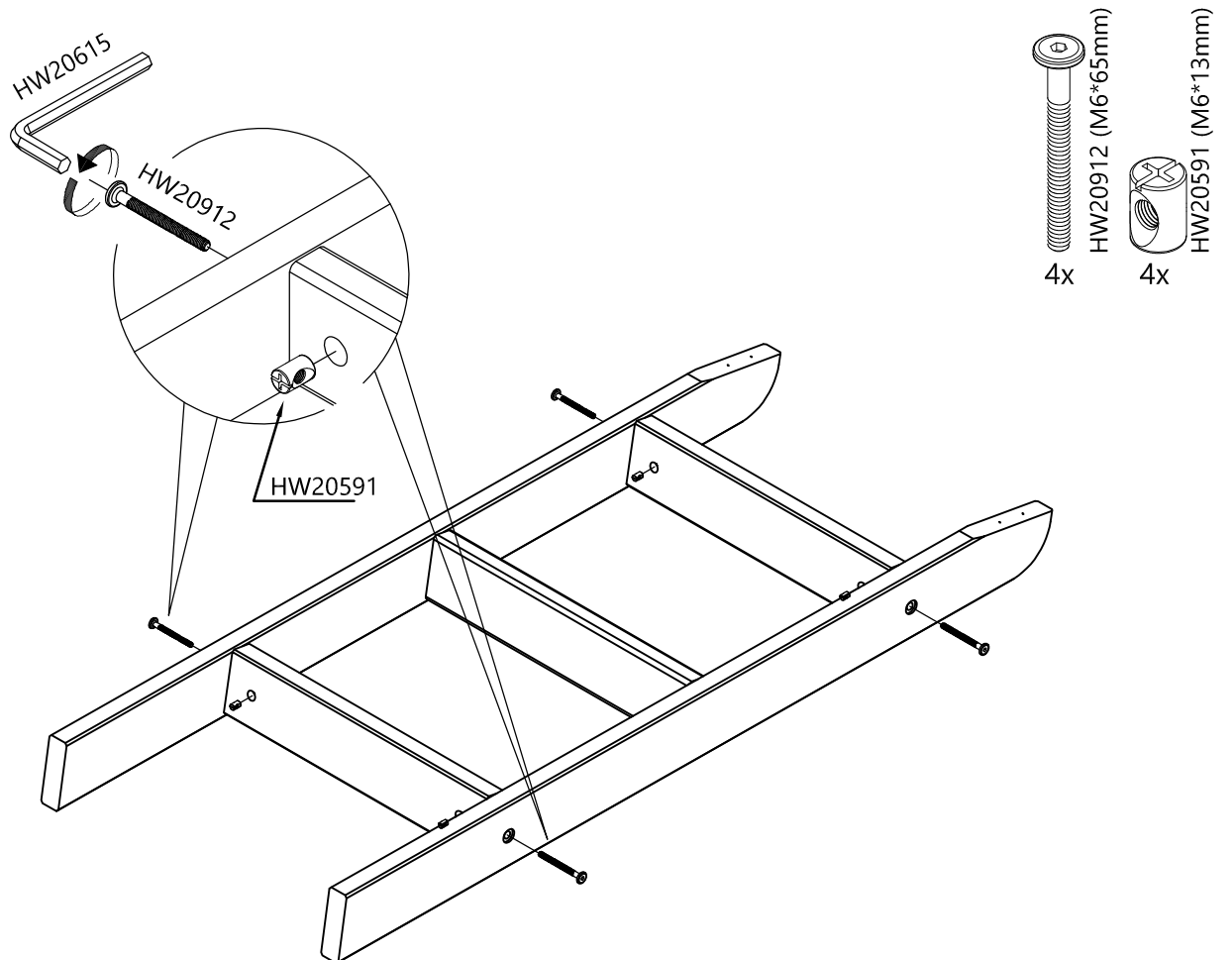
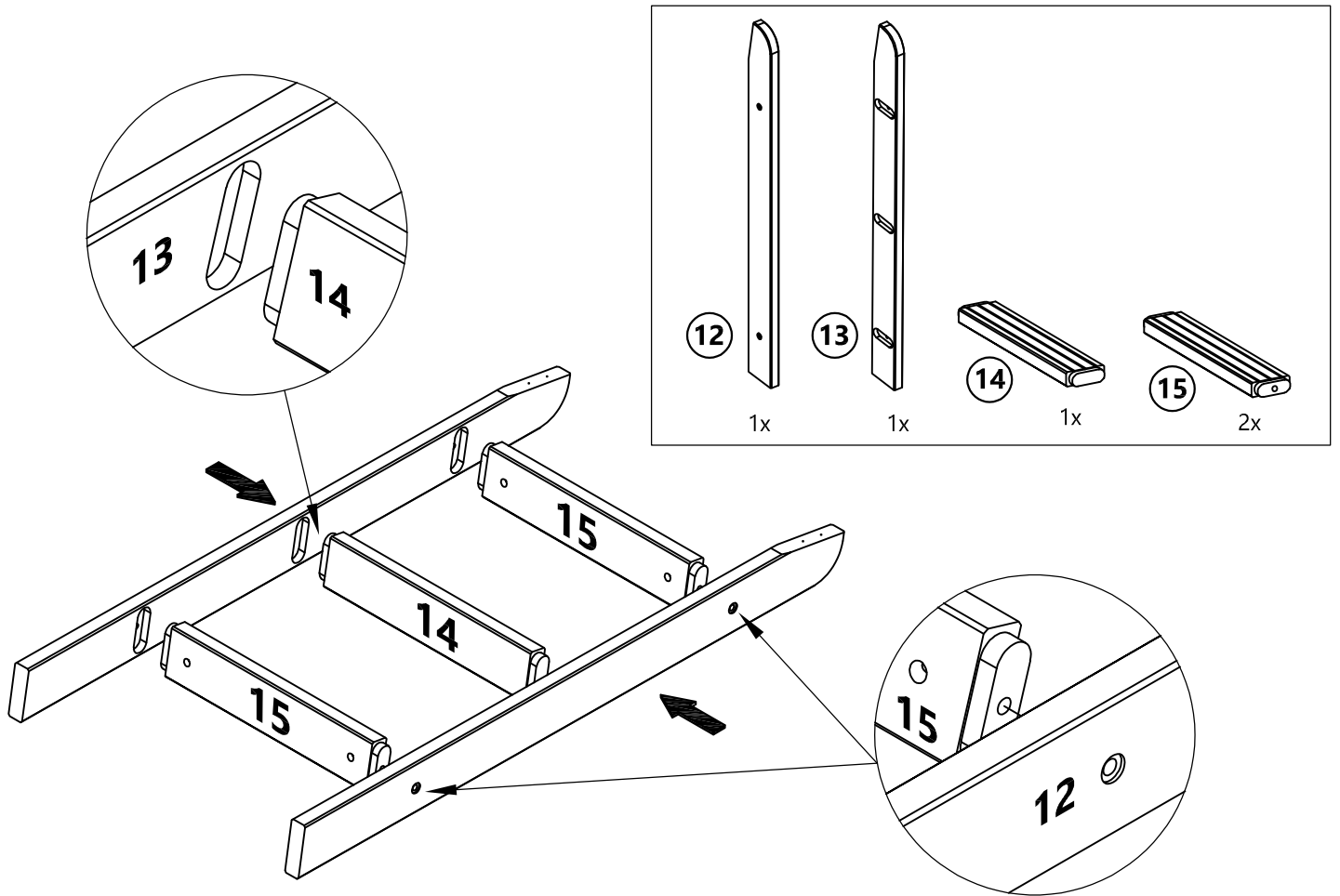

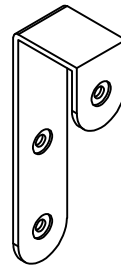

2x

HW20905 (72*26*21mm)



4x

HW20055 (4*30mm)



~~HW20012 (3*19mm)~~

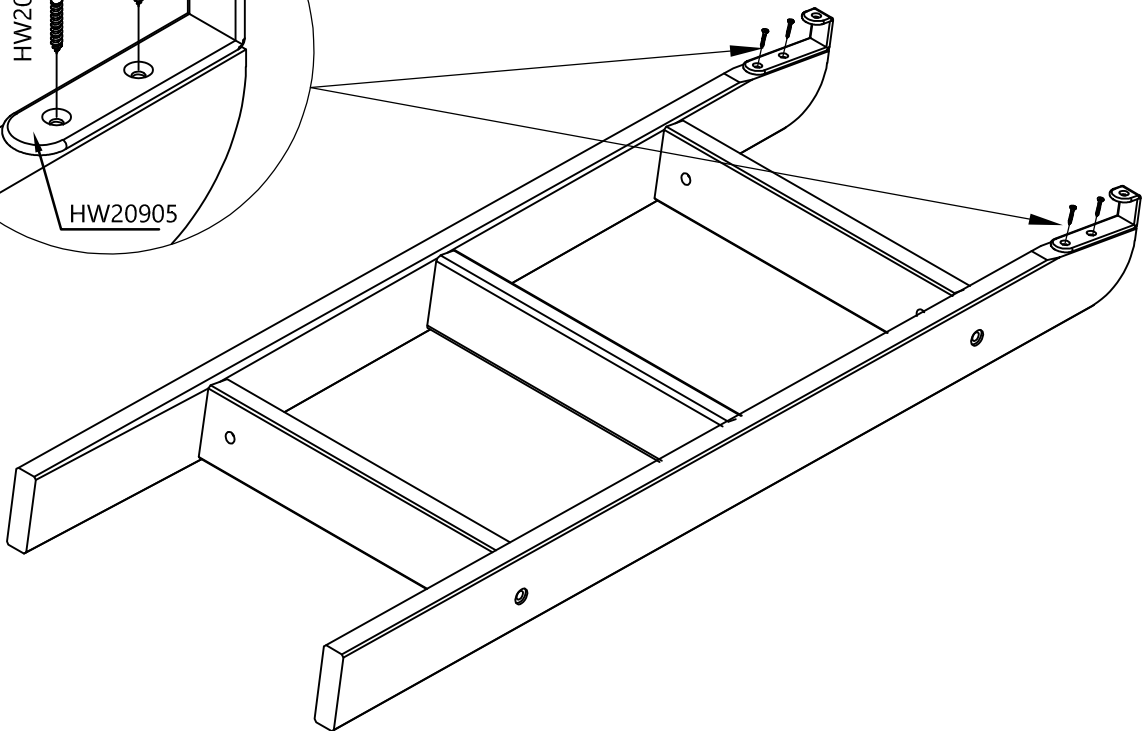
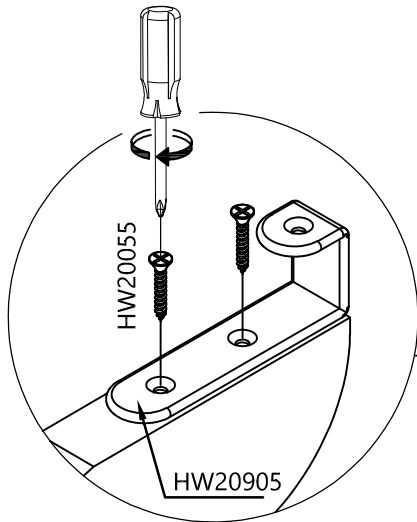

Left
Gauche
Izquierda

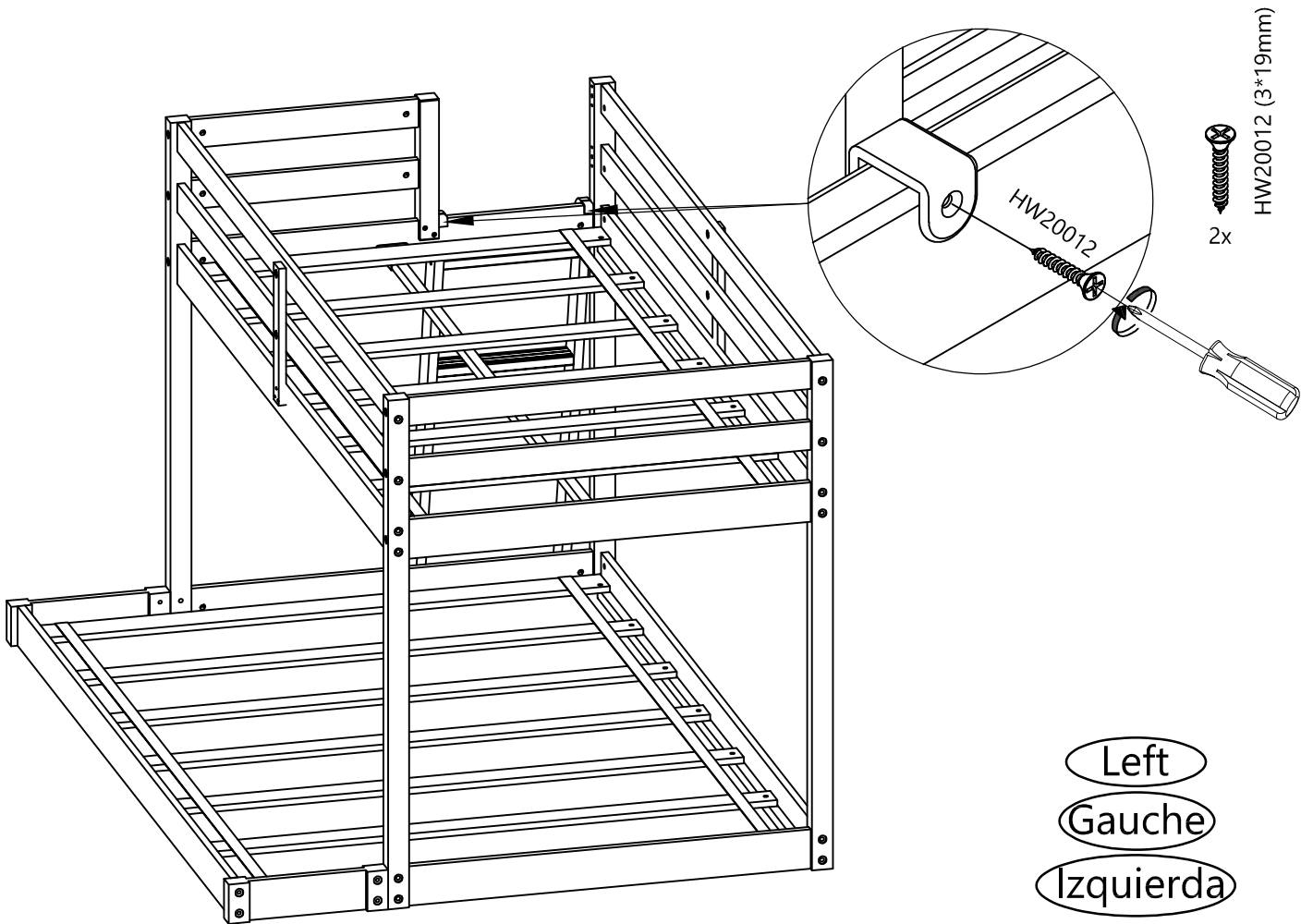
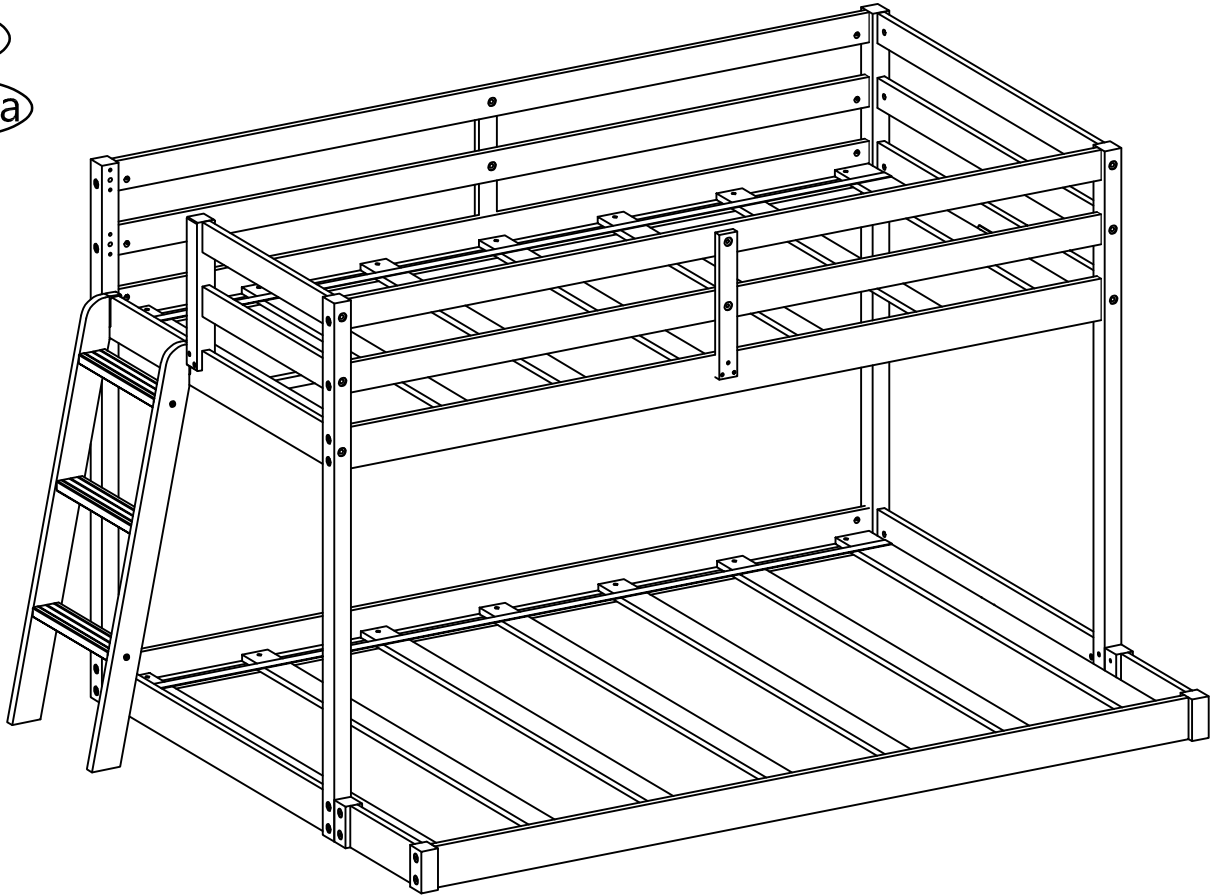

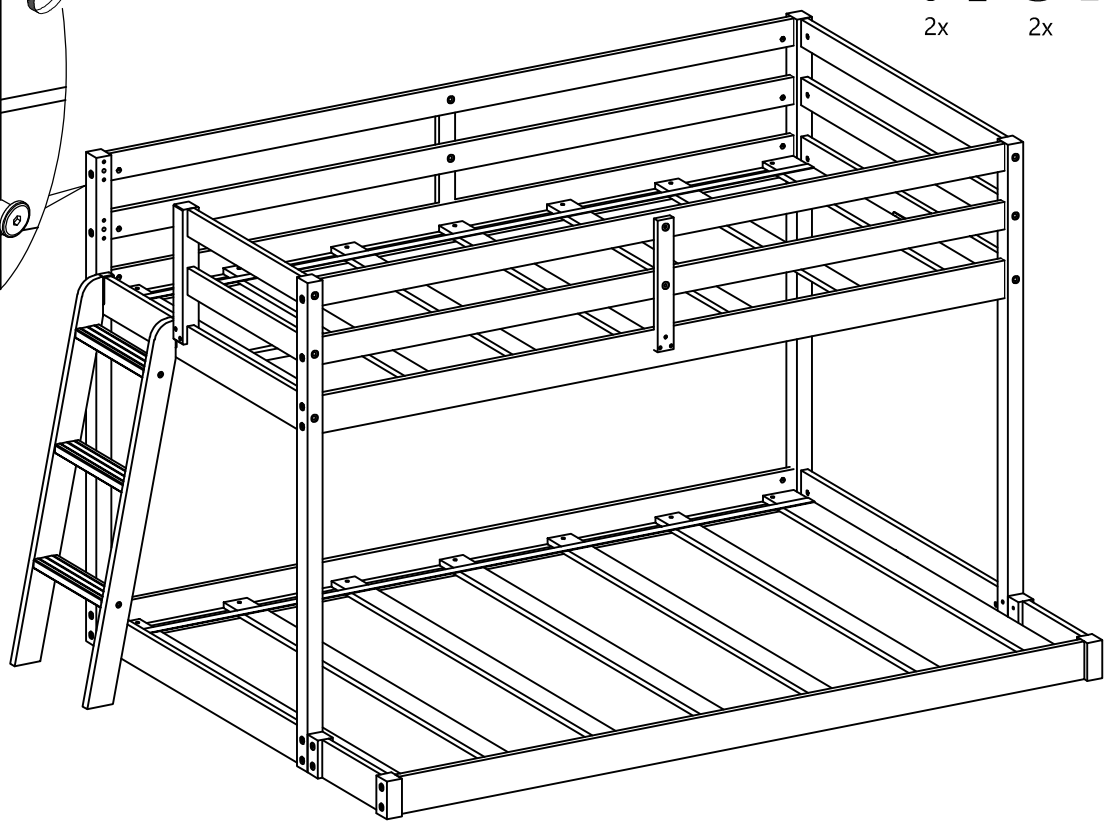
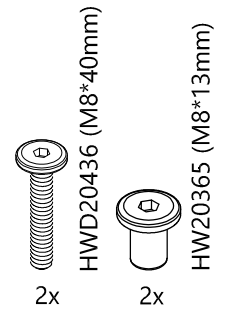
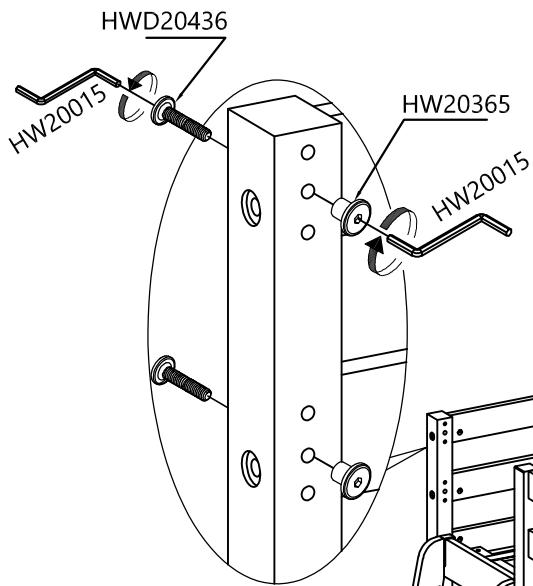

Left
Gauche
Izquierda

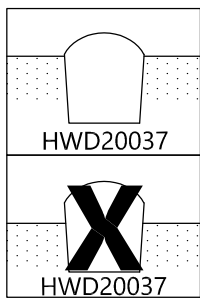
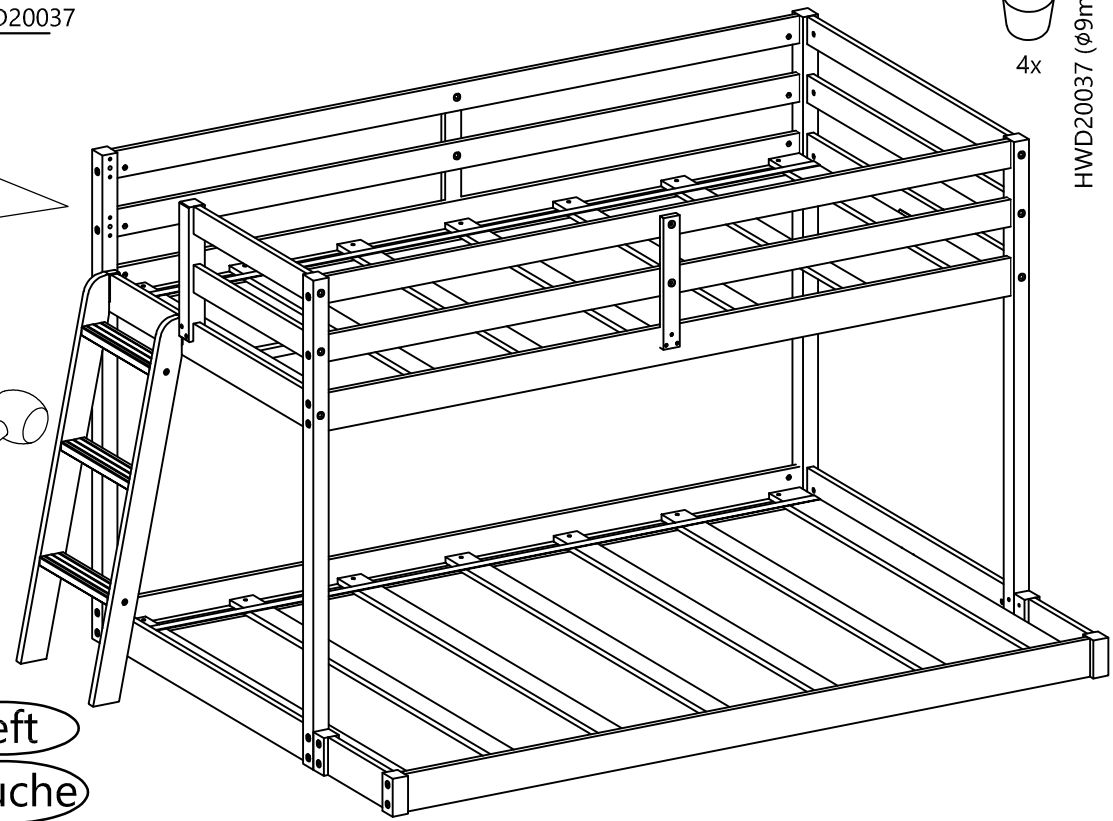
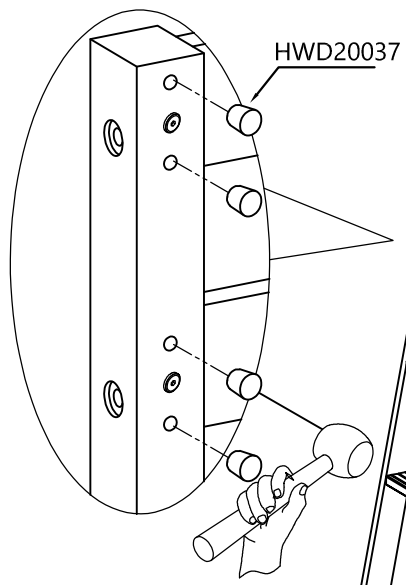

Left
Gauche
Izquierda

Right
Droit
Derecha

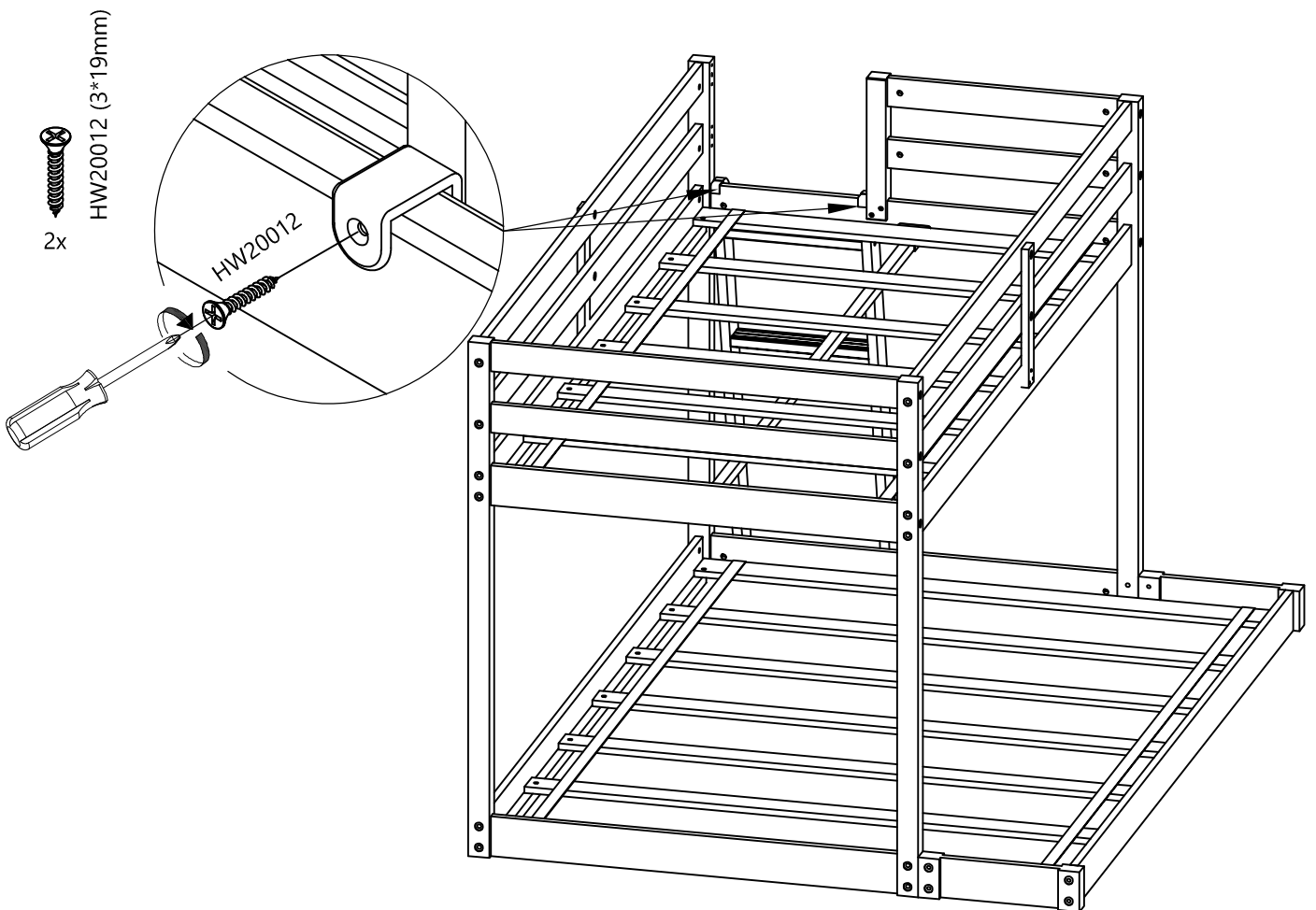
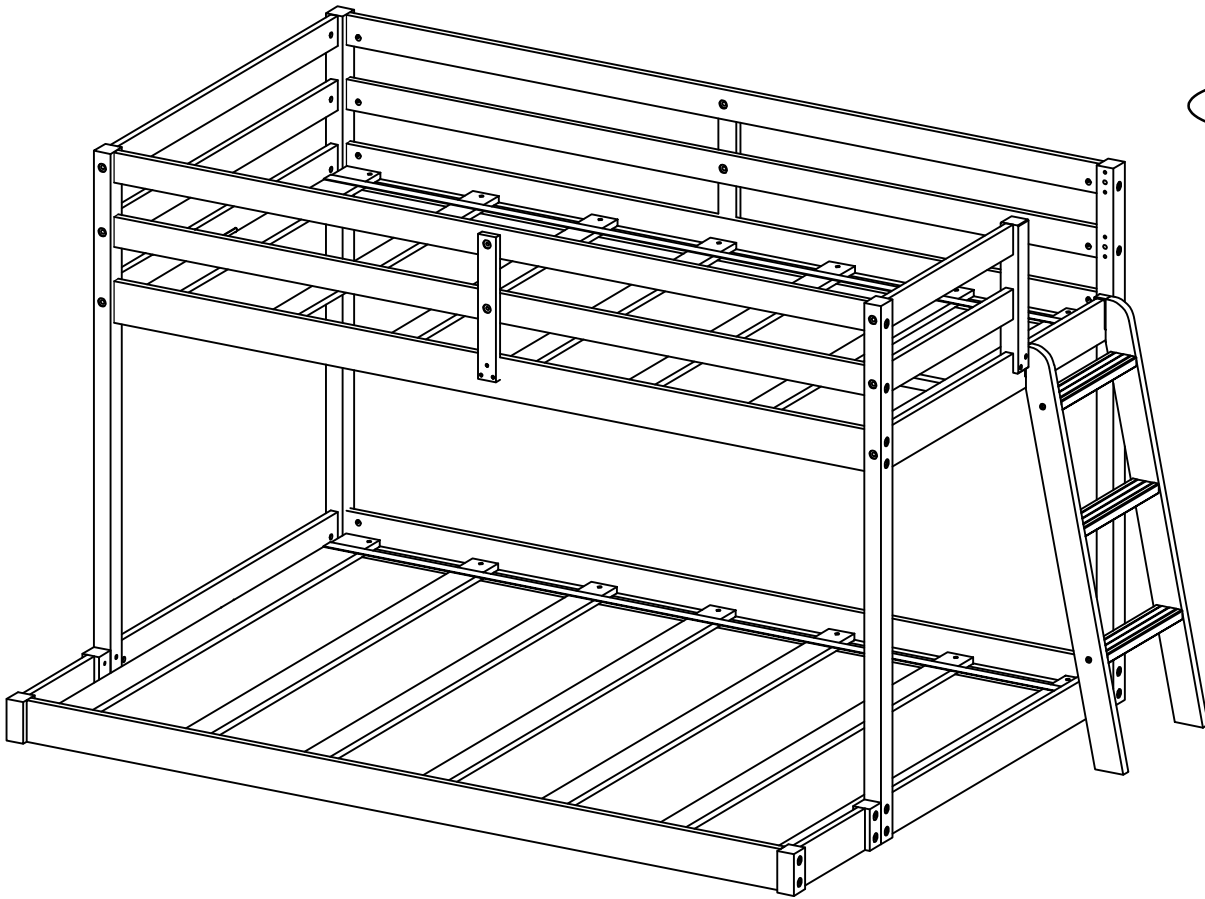

Right
Droit
Derecha

HWD20436 (M8*40mm) 2x
HWD20365 (M8*13mm) 2x

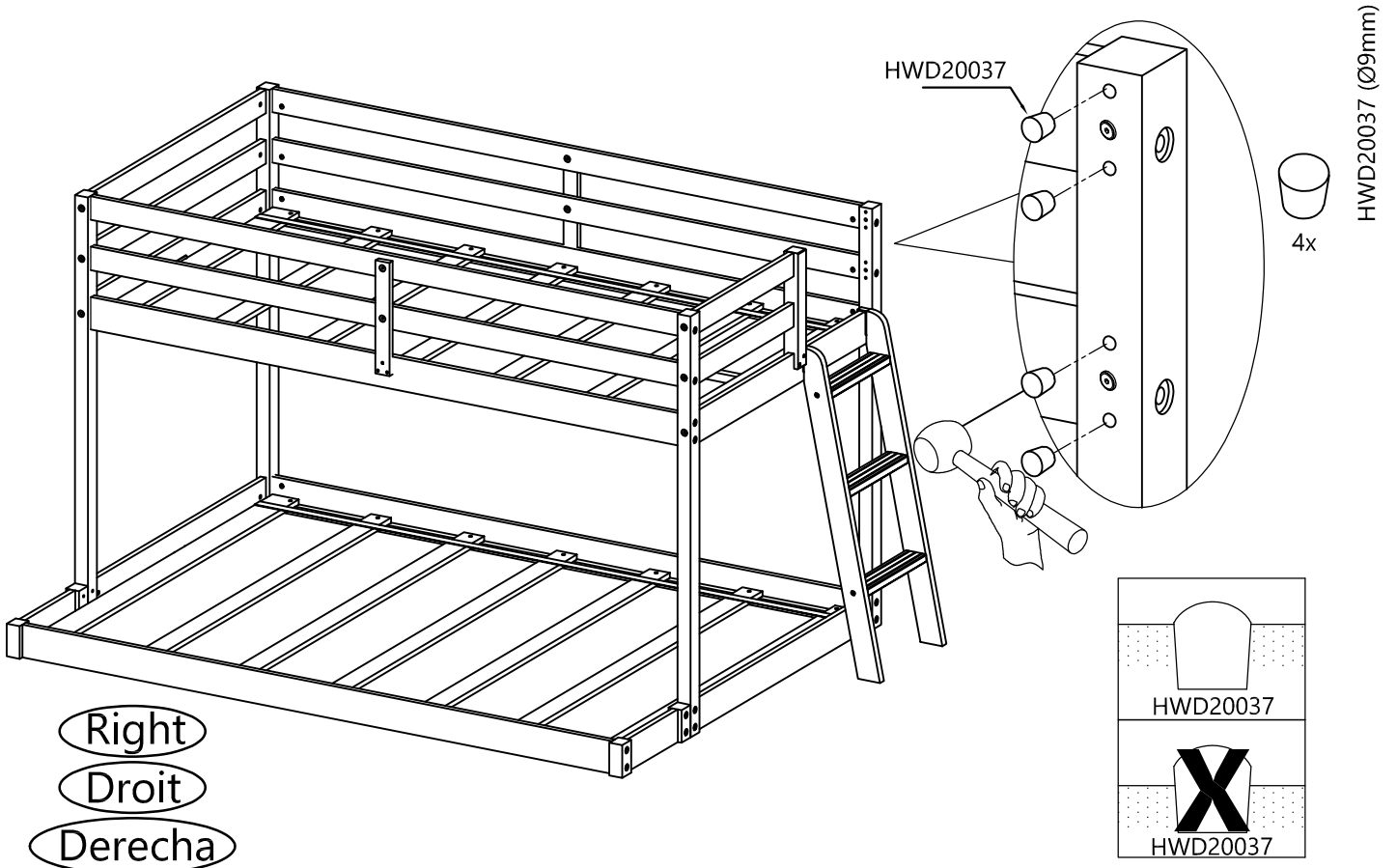
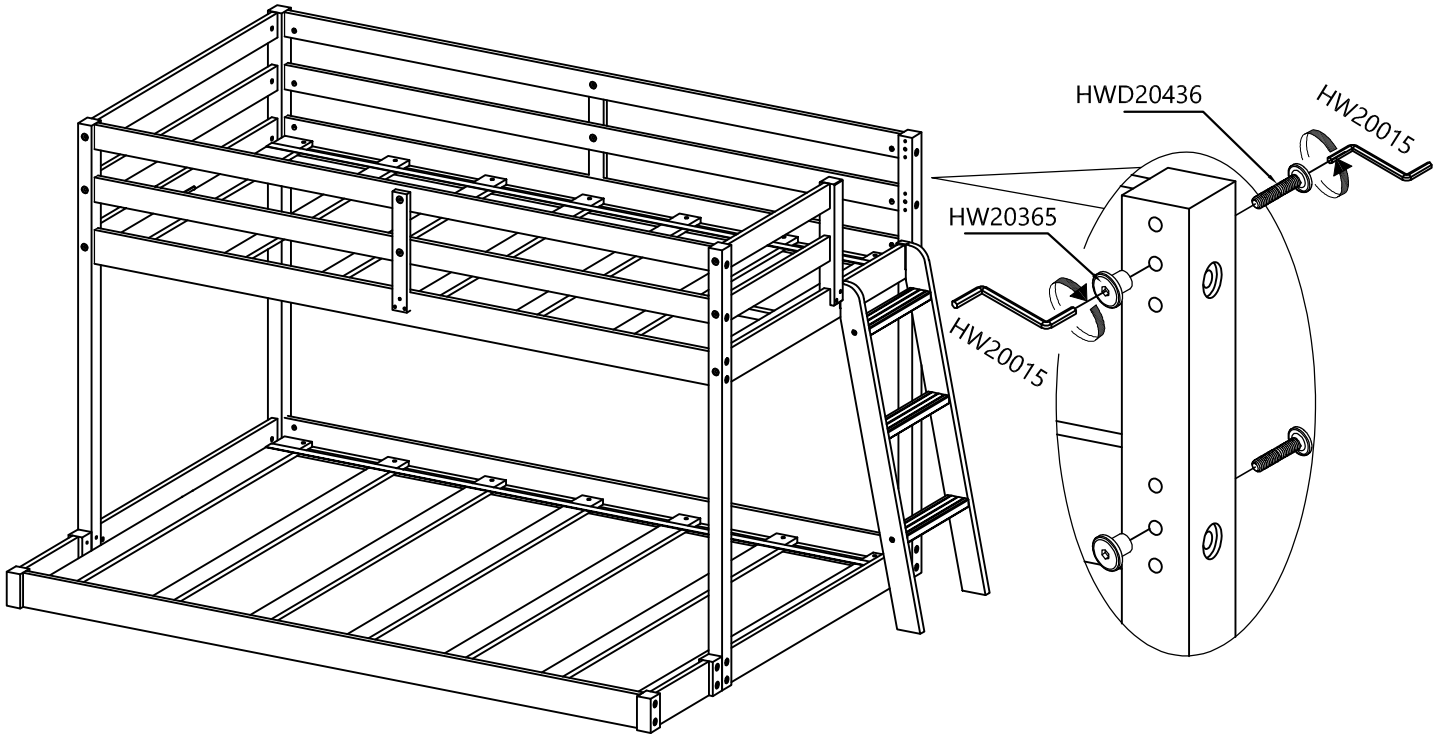

Right
Droit
Derecha

ENGLISH

Thank you for your purchase

We hope you and your kids will love it!

Please keep these assembly instructions for future reference.

Important:

Safety is our number one concern – please follow these simple safety tips:

Remember to check and tighten bolts/hardware once every few month, as these may loosen with use over time.

Make sure to anchor your large dressers to the wall with the free anti-tip kit provided.

Read and follow the safety instructions on the card attached to the front of your dresser.

Replacement Parts:

In case there is a problem with your product such as missing hardware, please contact your local dealer from whom you purchased the product, and they will be able to provide you with further information on how to obtain replacements.

FRANÇAIS

Merci pour votre achat de

Nous espérons que vous et vos enfants l'aimeront.

Veuillez conserver cette notice de montage pour une consultation ultérieure.

Important :

La sécurité est notre première préoccupation – veuillez suivre ces simples conseils de sécurité :

N'oubliez pas de vérifier et de serrer les boulons/la quincaillerie une fois tous les deux ou trois mois car ces derniers peuvent se desserrer avec le temps.

Assurez-vous d'ancrer vos grosses commodes au mur à l'aide de la trousse anti-basculement fournie.

Pièces de rechange :

En cas de problème avec votre produit comme de la quincaillerie manquante, veuillez contacter le distributeur local à qui vous avez acheté le produit, ce dernier pourra vous fournir plus d'information sur comment obtenir les pièces de rechange.

ESPAÑOL

Gracias por su compra de

que usted y sus hijos les encantará.

Conserve estas instrucciones de montaje para futuras consultas.

Importante:

La seguridad es nuestra preocupación número uno - siga estos sencillos consejos de seguridad:

Recuerde revisar y apretar tornillos / herrajes una vez cada pocos meses, ya que estos pueden aflojarse con el uso a lo largo del tiempo.

Asegúrese de anclar sus aparadores grandes a la pared con el kit anti-tip gratuito proporcionado. Lea y siga las instrucciones de seguridad de la tarjeta colocada en la parte frontal de la cómoda.

Piezas de repuesto:

En caso de que se produzca un problema con el producto, como el hardware faltante, póngase en contacto con

Su distribuidor local de quien adquirió el producto, y ellos podrán proporcionarle más información sobre cómo obtener los reemplazos.

ENGLISH

Size of Mattress and Foundation.

This bed is designed to use a mattress size 74" - 75" (188cm - 190cm) long and 37½"-38½" (95cm - 98cm) wide with twin size; 52½"-53½" (133cm - 135cm) wide with full size on upper and lower bunk.

Ensure thickness of mattress and foundation combined does not exceed 9" (23cm) on upper and lower bunk and mattress is at least 5" (13cm) below upper edge of guard rail.

Intended use of Single Beds and Day Beds is Age Group 3 Years and older (36 months and older). Intended use of raised beds including but not limited to Loft Beds and Bunk Beds is 6 Years and older (72 months and older).

SAFETY WARNINGS

1. Follow the information on the warnings appearing on the upper bunk bed end structure and on the carton. Do not remove warning label from bed.
2. Always use recommended size mattress or mattress support, or both, to help prevent the likelihood of entrapment or falls.
3. Surface of mattress must be at least 5" (13cm) below the upper edge of the guardrails.
4. Do not allow children under 6 years of age to use the upper bunk.
5. Periodically check and ensure that the guardrail, ladder and other components are in their proper position, free from damage and that the connectors are tight.
6. Do not allow horseplay on or under the bed and prohibit jumping on the bed.
7. Prohibit more than one person on the upper bunk.
8. Always use the ladder for entering and leaving the upper bunk.
9. Do not use substitute parts. Contact manufacturer or dealer for replacement parts.
10. Use of a night light may provide added safety precaution for a child using the upper bunk.
11. Always use guardrails on both long sides of upper bunk.
12. If the bunk bed will be placed next to a wall, the guardrail that runs the full length of the bed should be placed against the wall to prevent entrapment between the bed and the wall.
13. The use of water or sleep flotation mattresses is prohibited
14. Keep these instructions for future reference.

STRANGULATION HAZARD

15. Never attach or hang items to any part of the bunk bed that are not designed for use with the bed, for example but not limited to hooks, belts, and jump ropes.

Replacement Parts

Replacement parts, including additional guard rails, may be obtained from any of our dealers.

FRANÇAIS

Taille du matelas et du support.

Ce lit est conçu pour être utilisé avec un matelas d'une longueur de 74"-75" (188cm à 190cm) et d'une largeur de 37½"-38½" (95cm à 98cm) avec un lit jumeau ; de 52½"-53½" (133cm à 135cm) avec un lit double pour les lits supérieur et inférieur.

Assurez-vous que l'épaisseur combinée du matelas et du support ne dépasse pas 9" (23cm) supérieur et inférieur du lit, et que le matelas soit sous la partie supérieure du rail de sécurité d'au moins 5" (13cm).

Utilisation de Lits Simples et Lits de Repos prévue pour Tranche d'Âge 3 Ans et plus (36 mois et plus) "Utilisation de Lits surélevés comprenant, mais pas exclusivement, des Lits Mezzanine et Lits Superposés prévue pour 6 Ans et plus (72 mois et plus).

AVERTISSEMENTS DE SÉCURITÉ

1. Suivez les avertissements affichés sur la partie supérieure de la structure du lit et sur le carton. Ne retirez pas l'étiquette du lit.
2. Utilisez toujours les tailles recommandées pour le matelas ou le support, ou les deux, pour prévenir les chutes ou le risque de rester coincé.
3. La surface du matelas doit être au moins 5" (13cm) sous la partie supérieure des rails de sécurité.
4. Ne laissez pas des enfants âgés de moins de 6 ans utiliser le lit supérieur.
5. Vérifiez régulièrement et assurez-vous que le rail de sécurité, l'échelle et les autres composants sont en bonne position, sans dommages et que les raccords sont bien serrés.
6. Interdisez tout chahut sur ou sous le lit et interdisez de sauter sur le lit.
7. Interdisez plus d'une personne sur le lit du dessus.
8. Utilisez toujours l'échelle pour accéder au lit supérieur ou pour en descendre.
9. N'utilisez pas de pièces de substitution. Veuillez contacter le fabricant ou le revendeur pour des pièces de remplacement.
10. L'utilisation d'une veilleuse peut offrir une sécurité supplémentaire lorsqu'un enfant utilise le lit supérieur.
11. Utilisez toujours des rails de sécurité des deux côtés longs du lit supérieur.
12. Si le lit superposé est placé à côté d'un mur, le rail de sécurité qui longe tout un côté du lit doit être placé contre le mur pour empêcher d'être coincé entre le lit et le mur.
13. Il est interdit d'utiliser des matelas à eau ou des matelas pneumatiques.
14. Conservez ces instructions pour une référence future.

RISQUE D'ÉTRANGLEMENT

15. N'attachez ou ne pendez jamais d'objets ou toute autre partie du lit superposé qui n'a pas été conçu pour être utilisé avec le lit, par exemple des crochets, des courroies ou des cordes à sauter.

Pièces de remplacement

Les pièces de remplacement, y compris des rails de sécurité supplémentaires, doivent être obtenues chez nos revendeurs

ESPAÑOL

Tamaño del colchón y la base.

Esta cama está diseñada para utilizar un colchón de tamaño 74"-75" (188cm-190cm) de largo y 37½"-38½" (95cm-98cm) de ancho con tamaño sencillo; 52½"-53½" (133cm-135cm) de ancho con tamaño doble en litera de superior e inferior.

Asegúrese que el espesor del colchón y la base combinados no exceda los 9" (23cm) en la parte superior e inferior de la litera y que el colchón esté al menos 5" (13cm) por debajo del borde superior de la barandilla.

El uso previsto de camas individuales y sofás cama es para edades de 3 años o más (36 meses o más). El uso previsto de camas elevadas, incluidas, entre otras, las camas altas y literas es de 6 años o más (72 meses o más).

ADVERTENCIAS DE SEGURIDAD

1. Siga la información en las advertencias que aparecen en la estructura final superior de la cama de la litera y en la caja de cartón. No retire la etiqueta de advertencia de la cama.
2. Utilice siempre el tamaño del colchón o del soporte del colchón recomendados, o ambos, para ayudar a prevenir el riesgo de atrapamiento o caída.
3. La superficie del colchón debe de ser de al menos 5" (13cm) pulgadas por debajo del borde superior de las barandas.
4. No permita que los niños menores de 6 años de edad utilicen la *litera superior*.
5. Periódicamente verifique y asegúrese que la barandilla, escalera y otros componentes estén en su posición correcta, libre de daños y que los conectores estén apretados.
6. No permita juegos bruscos en o debajo de la cama y prohíba saltar en la cama.
7. Prohíba más de una persona en la litera superior.
8. Siempre use la escalera para entrar y salir de la litera de arriba.
9. No utilice piezas de sustitución. Consulte al fabricante o al distribuidor para pedir piezas de repuesto.
10. El uso de una luz de noche puede proporcionar seguridad adicional para un niño que usa la litera superior.
11. Utilice siempre barandas largas a ambos lados de litera superior.
12. Si la litera se coloca al lado de una pared, la barandilla que recorre toda la longitud de la cama debe de ser colocada contra la pared para evitar el atrapamiento entre la cama y la pared.
13. Está prohibido el uso de colchones de agua o de flotación
14. Guarde estas instrucciones como referencia futura.

PELIGRO DE ESTRANGULACIÓN

15. Nunca una ni cuelgue objetos a ninguna parte de la litera que no estén diseñados para su uso con la cama, por ejemplo, pero no limitado a ganchos, cinturones y cuerdas para saltar.

Piezas de repuesto

Las piezas de repuesto, incluyendo las barandas de seguridad adicionales, se pueden obtener en cualquiera de nuestros distribuidores de muebles