

## ASSEMBLY INSTRUCTIONS

### ITEM NO . : T 409

Please read instructions carefully





Remove all wrapping materials, staples and packing straps from the carton. Refer to Parts List and Hardware List and ensure they are complete before you start assembling. Place all wooden parts on a clean, flat and soft surface (e.g carpet or rug) to prevent parts from being scratched.

- CAUTIONS: 1) DO NOT FULLY TIGHTEN BOLTS AND NUTS UNTIL ALL PARTS HAVE BEEN ASSEMBLED.  
 2) DO NOT OVER-TIGHTEN BOLTS AND NUTS UNTIL ALL PARTS HAVE BEEN ASSEMBLED.  
 3) KEEP ALL HARDWARE PARTS OUT OF REACH OF CHILDREN.

#### PARTS LIST

NO.	COMPONENT	QTY.
P1	TABLE TOP	1
P2	PEDESTAL LEG	1
P3	MOUNTING PANEL	1

#### HARDWARE LIST

NO.	DESCRIPTION	QTY.
H1	JCBC SCREW M6X35MM 	8
H2	SPRING WASHER 	8
H3	FLAT WASHER 	4
H4	ADJUSTABLE LEG GLIDE 	8
H5	WOOD DOWEL M8 X 30MM 	4
H6	ALLEN KEY 	1

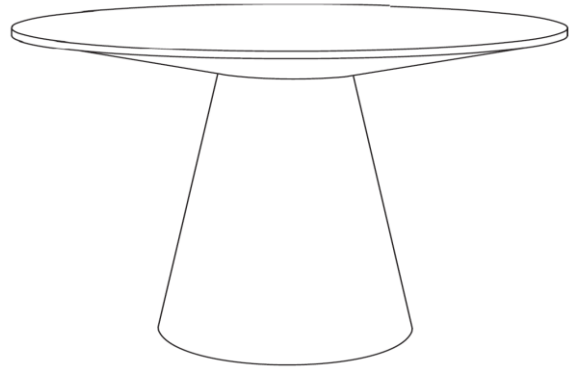

COMPLETE ASSEMBLY

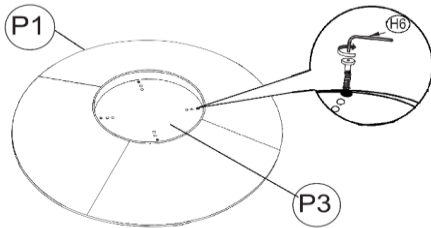

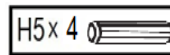

**IMPORTANT :** Detach Mounting Panel (P3) from table top (P1) before assembling the table

#### STEP 2





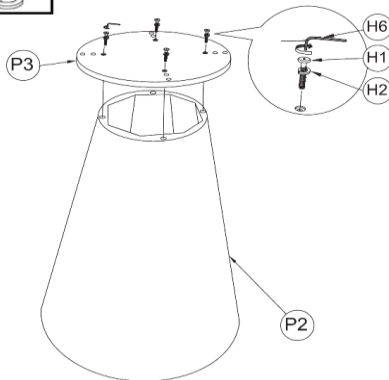

Install the wooden dowels H5 , the dowels are for the table legs assembly aligning guide .

#### STEP 1

H1 X 4	 M6 x 35mm
H2 X 4	



#### STEP 3

H1 X 4	 M6 x 35mm
H2 X 4	
H3 X 4	
H4 X 8	

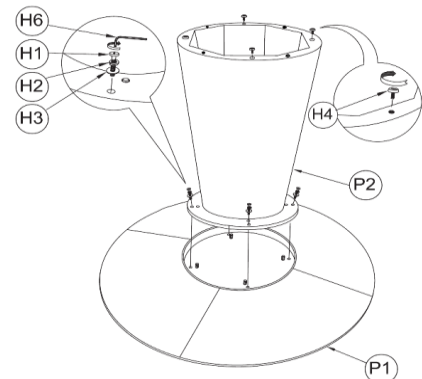

**CAUTION ! :** REQUIRES TWO ADULTS TO TURN THE TABLE UPRIGHT AFTER FINISHED ASSEMBLY .



#### CARE AND MAINTENANCE







**SAFETY** - To avoid any risk of suffocation to children or animals, dispose off the plastic bags immediately.

**CLEANING** - Clean with damp cloth and mild detergent. Do not use bleach or abrasive products.

**FITTINGS** - Tighten bolts and nuts from time to time to ensure all parts of product are securely fitted.

Thank you for purchasing this quality product. Be sure to check all packing materials carefully for small parts, which may have come loose inside the carton during shipment. Identify and count all items and compare with the parts list and/or hardware list shown below.

PARTS LIST(2 CHAIRS)			
No.	DESCRIPTION	SKETCH	Q'TY
A	SEAT FRAME WITH CUSHION		2
B	BACK FRAME WITH CUSHION		2
C	FRONT LEG		4

HARDWARE LIST(2 CHAIRS)			
No.	DESCRIPTION	SKETCH	Q'TY
1	ALLEN BOLT (5/16" x 3-1/4")		8
2	ALLEN BOLT (5/16" x 2-1/4")		8
3	ALLEN BOLT (5/16" x 1-1/2")		4
4	SPRING WASHER (5/16 ")		20
5	FLAT WASHER (5/16 ")		20
6	ALLEN KEY M5		2

**DO NOT TIGHTEN LEGS UNTIL THE CHAIR IS FULLY ASSEMBLED**

STEP : 1

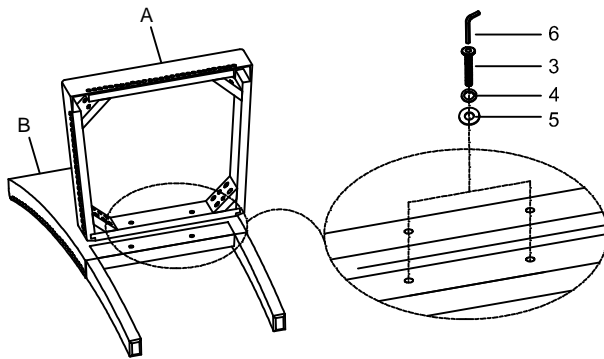

STEP : 2

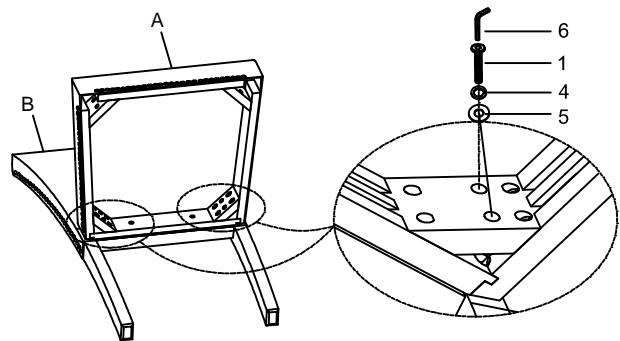

STEP : 3

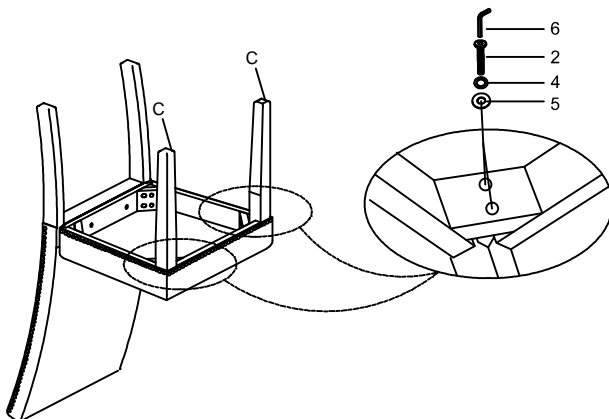

STEP : 4

