

ASSEMBLY INSTRUCTION INSTRUCTIONS DE MONTAGE

Queen Size

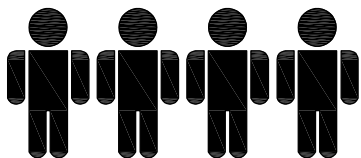
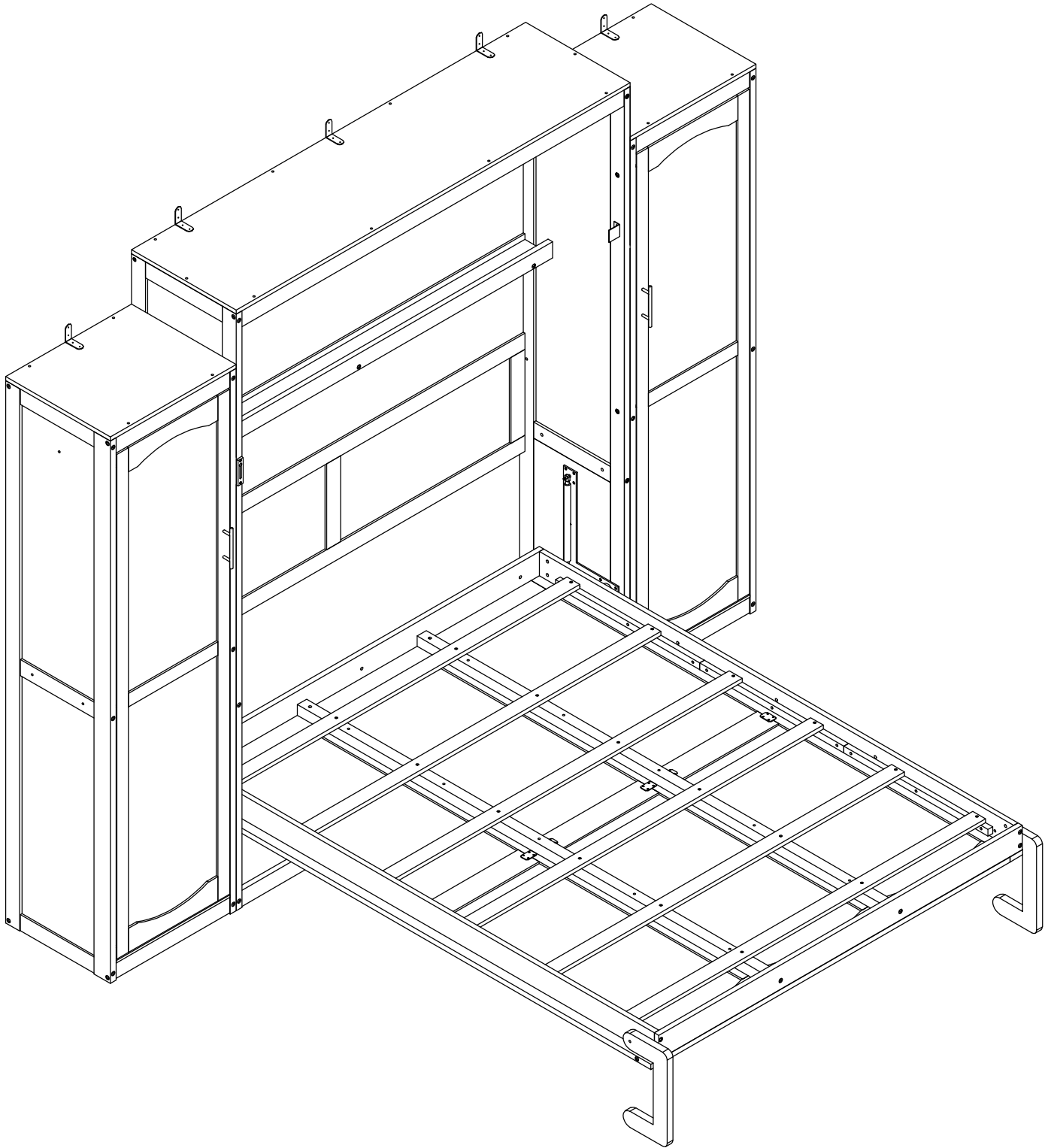

Four people are required to assemble and
move this model
Quatre personnes sont nécessaires pour
assembler et déplacer ce modèle

Important information to read before starting the assembly.
Keep this information for future reference.

IMPORTANT WARNINGS



Risk of serious injuries if the wall bed tips over.

To prevent wall bed from tipping over, mount it permanently to the wall.

Only a qualified person* must carry out the installation and any possible adjustment of the wall bed (including disassembly). If the wall bed is not firmly mounted (anchored) to the wall, it might tip over and cause serious injuries to the installer, users of the bed as well as the people near the bed.

The choice of wall anchoring depends on the type of wall. Use wall anchors suitable for the wall material.

*Qualified person: it is necessary to have a good understanding of the wall structure where the bed is anchored, including the positioning of the wall studs and structural components in the case of a wood or metal structure. If you do not have the necessary skills, make sure that the installation is done by someone who has the qualifications and required knowledge. When you choose the installer, make sure to comply with all applicable regulations in the province, state or country where the furniture is installed.

Informations importantes à lire avant de commencer l'assemblage.
Conservez ces informations pour référence future.

AVERTISSEMENTS IMPORTANTS



Risque de blessures graves en cas de basculement du lit escamotable.

Pour éviter tout basculement, fixez-le de manière permanente au mur.

Seule une personne qualifiée* doit effectuer l'installation et tout éventuel réglage du lit escamotable (y compris le démontage). Si le lit escamotable n'est pas solidement fixé (ancré) au mur, il risque de basculer et de provoquer de graves blessures à l'installateur, aux utilisateurs du lit ainsi qu'aux personnes à proximité.

Le choix du système de fixation dépend du type de mur. Utilisez des ancrages adaptés au matériau du mur.

*Personne qualifiée: Il est nécessaire d'avoir une bonne compréhension de la structure du mur où le lit est ancré, y compris la position des montants et des éléments structurels dans le cas d'une ossature en bois ou en métal.

Si vous ne possédez pas les compétences requises, assurez-vous que l'installation est réalisée par une personne qualifiée et possédant les connaissances nécessaires. Lors du choix de l'installateur, veillez à respecter toutes les réglementations en vigueur dans la province, l'État ou le pays où le meuble est installé.

IMPORTANT INFORMATION PACKAGE.

**THIS INFORMATION PACKAGE CONTAINS WARNING AND
PRODUCT SAFETY INFORMATION. DO NOT PROCEED
WITHOUT REVIEWING THOROUGHLY.**

A. WARNING LABELS.

Your purchased Murphy Bed is delivered to you with **WARNING LABELS** to constantly remind you to take and adopt Safety Measure throughout the entire assembly and mounting points of the Bed to the walls.

DO NOT REMOVE these labels.

These Warning Labels serve as a Reminder Tool for visiting friends and relatives when using the Murphy Bed to ensure Safety Precautions are taken.

**WARNING.**

IMPORTANT SAFETY REQUIREMENTS - Bed Attachment to Wall.
For Your Safety, the Murphy Bed MUST BE ATTACHED to the Wall.

Seek Certified Professional Consultant / Contractors for their Services to:

- 1.) DETERMINE the WALL Type in Your Home;
- 2.) PRECISE HARDWARE that suits to the Wall Type in Your Home;
- 3.) INSTALL / ATTACH of the Murphy Bed to the Wall in Your Home;
- 4.) VALIDATE the Murphy Bed is appropriately and securely installed/attached.

The choice of wall anchoring hardware depends on the type of wall. This Murphy Bed is delivered with **HARDWARE SCREWS** suited for attachment to **WOOD STUDS** in walls. Any **STUDS** type detected with your Consultant-Contractors to be **NOT WOOD STUDS** - **DISCARD** and **DO NOT USE** these **SCREWS**. Use the hardware suitable for your wall material.

Seek the professional advice of your Consultant-Contractor and procure the appropriate hardware and brackets for the attachment of the Murphy Bed to the Wall.

FAILURE TO ADHERE TO THE ABOVE INSTRUCTIONS MAY RESULT IN SERIOUS and/or SEVERE INJURIES or Death caused by the detachment of the Murphy Bed from the Wall.

SAFETY PRECAUTION :

1.) **MAXIMUM** Mattress Weight suited to your Murphy Bed : __lbs (__kg);
 MAXIMUM mattress thickness: __ inches (__ cm);
2.) **ENSURE ADULTS ONLY** throughout the entire assembly and attachment.
3.) **KEEP ALL Children, Non-Ambulatory persons and Pets** at bay during the entire assembly and attachment.

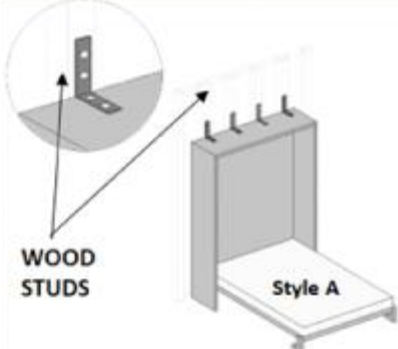

WOOD STUDS

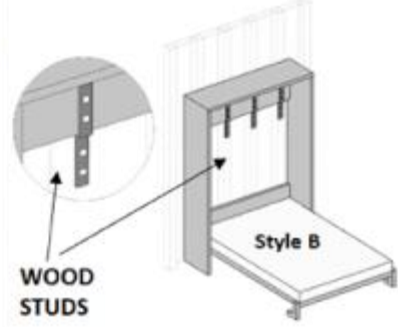

WOOD STUDS

LINE ART for Reference only and NOT DRAWN TO SCALE.

CAUTION : Homes are renovated differently. There are CONCRETE walls and "hollow walls". Hollow walls are reinforced with STUDS of Wooden or Steel Materials. Seek advice from professionals.

Style A - VERTICAL Murphy Bed with SEALED/CLOSED Back board.

Style B - VERTICAL Murphy Bed with OPEN STYLE Back board.

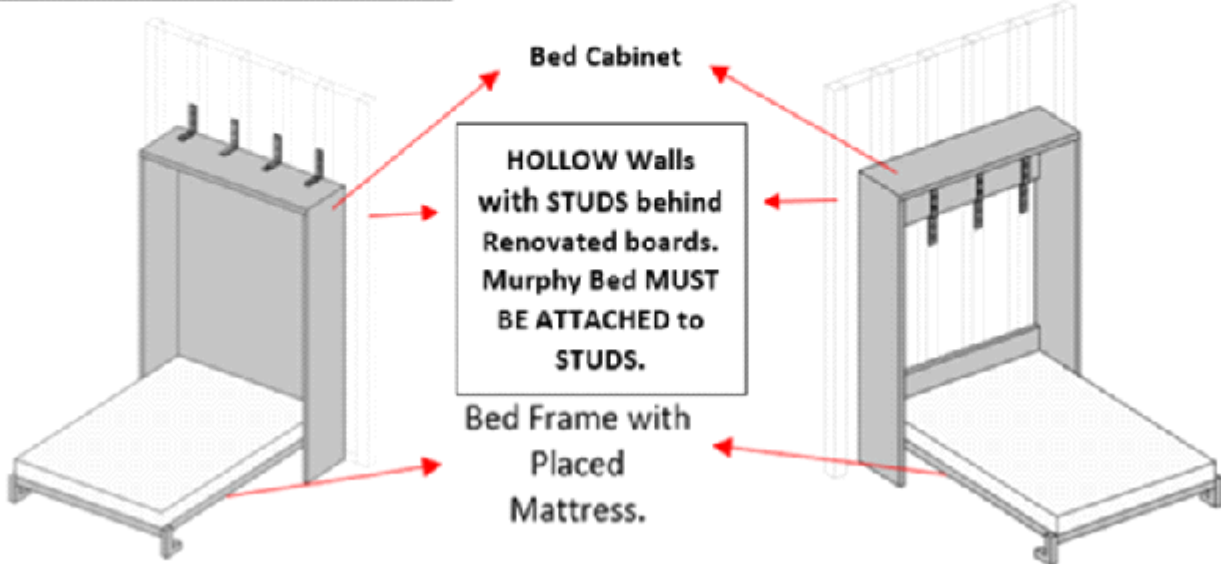

B.) SAFETY REMINDERS.

MARKINGS in WALL – WHERE TO ATTACH the MURPHY BED.

Irrespective of the wall type, whether Solid Concrete Walls OR Decorative Walls with WOODEN Studs OR Decorative Walls with Metal Studs, ensure that

- a.) you choose a professional installer who has a good understanding of the wall structure where the Murphy Bed is anchored, including the position of the wall studs and structural components in the case of a wood or metal structure.
- b.) precise markings of the positions of the anchor points are to be made on the wall for easy identification during the Murphy Bed attachment to the wall.
- c.) the relevant and appropriate Hardware with Metal Brackets are READY for this attachment and are within easy access for prompt and efficient attachment.

This product requires Professional Consultation and Installation*.

* When you choose the professional installer, make sure to comply with all applicable laws, regulations and rules in the city, state or country where the Murphy Bed is installed.

To have your Murphy Bed fully assembled and to achieve its intended functionality – you **MUST READ** through this entire Assembly Instructions Manual before you start the assembly of the bed

1.)There are numerous Safety Issues and Safety Precautionary Actions that you MUST KNOW before you start the Assembly.

2.)CAUTION - Failure to FOLLOW / ADHERE to the GUIDE, WARNING AND REMINDERS here, may result in serious / severe injuries or death.

3.)PRECAUTION : For the assembly, Adult Partners only, to assist in the entire assembly. Ensure 4 (four) to 6 (six) ABLE BODIED PERSONS ONLY in the entire assembly and attachment of this Murphy Bed to the walls of your home.

4.)CAUTION : During the entire assembly process and attachment of the Murphy Bed to the walls of your home, Keep ALL Children, Non-Ambulatory Persons and Pets completely at bay.

5.)SAFETY REMINDER on / to : Personal, Family Members and Pets. The Murphy Bed may be shipped to you in 3 to 5 packages and are HEAVY. Each carton holds many parts and components. Some of these components eg., bolts and screws are relatively small* in size.

***. During the assembly process, ensure that any misplaced bolts and nuts are picked up so that Children and or Pets do not play or ingest these.**

6.)This Murphy Bed is intended for ADULT USE ONLY.

7.) This Murphy Bed is delivered to you pre-packed with Hardware - suitable for wood-framed walls renovated with WOOD STUDS ONLY.

8.)Your Home's Wall Type - Every home is renovated differently with different wall(s) type / finishes. Before you proceed to assemble your Murphy Bed :

- a.) SEEK and CONSULT Professional Services to ascertain the wall type in the designated location where you intend to attach the Murphy Bed;
- b.) ENSURE the Consultant-Contractor specifically INFORMS you of the WALL TYPE in the designated spot where you intend to attach the Murphy Bed.
- c.) ENSURE the Consultant INFORMS you specifically on the matching and relevant Hardware / Brackets to secure and attach the Murphy Bed to the wall.

9.)WARNING – YOU MUST HEED THE INSTRUCTIONS given by your appointed Consultant-Contractor on the :

- a.) Mounting Hardware Type that suits the wall(s) type - where / when it is NOT WOOD STUDS, the pre-packed Screws for Wood Stud Walls would not match/ not fit.
- b.) Number of Mounting Points for the Murphy Bed to the Wall.

CAUTION : Homes are renovated differently. There are **CONCRETE** walls and "hollow walls". Hollow walls are reinforced with **STUDS** of Wooden or Steel Materials. Seek advice from professionals.

Style A - VERTICAL Murphy Bed with SEALED/CLOSED Back board.

Style B - VERTICAL Murphy Bed with OPEN STYLE Back board.

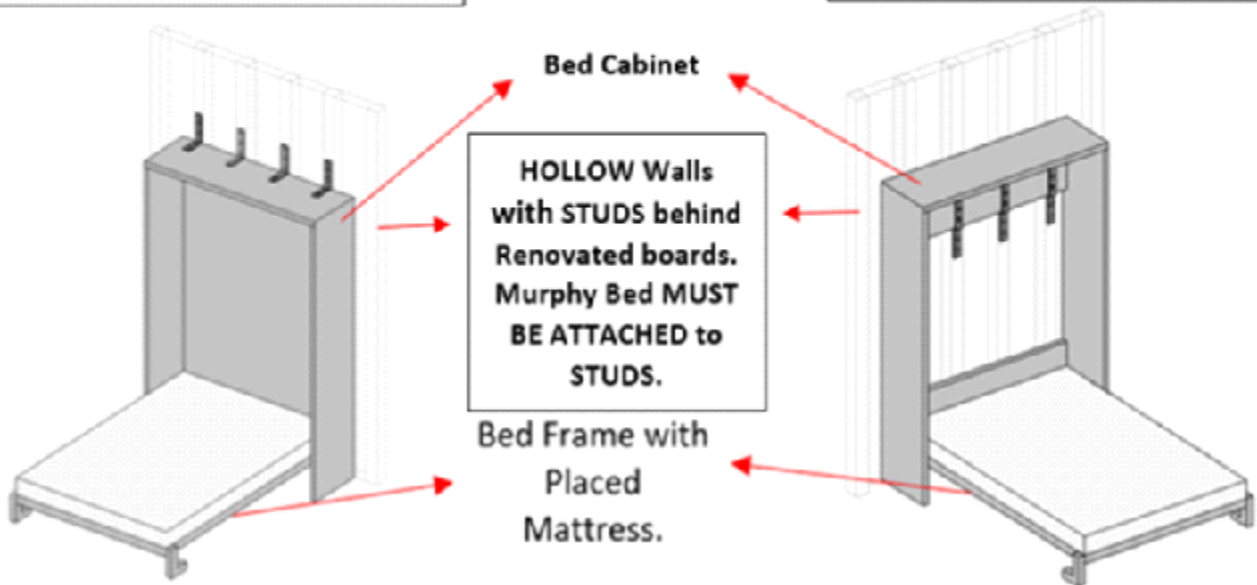

10.) This Murphy Bed is designed for home use and not intended for commercial use.

11.) This Murphy Bed is not intended to be moved, modified, uninstalled or disassembled once professionally installed.

C.) MOUNTING INFO & HARDWARE.

1.) REMINDERS:

- a.) In the event, that this pre-packed ScrewsSet does not match to the walls in your home – **DO NOT USE / DISCARD** these hardware.
- b.) **ADHERE** to the Professional Consultant-Contractor instructions and information on the **RELEVANT** mounting hardware that suits your wall.
- c.) Procurement of these **RELEVANT** hardware is an arrangement made between your Consultant-Contractor and you.

2.) A step ladder (not provided) is needed to attach the L-Brackets to the wall, at the Top of the Murphy Bed. DO NOT lean against the Top of the Murphy Bed, it may cause sagging.

Murphy Bed Style A

L-Bracket Fixture to Wood Studs

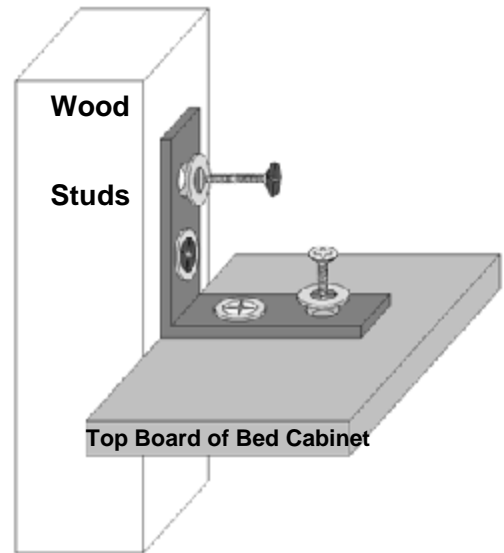
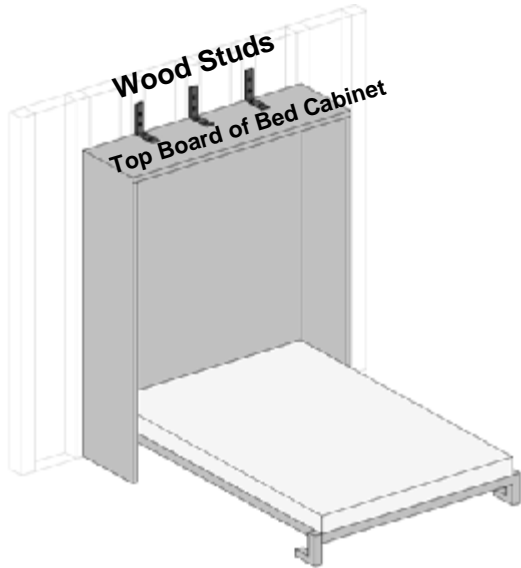

Z-Bracket Fixture to Wood Studs

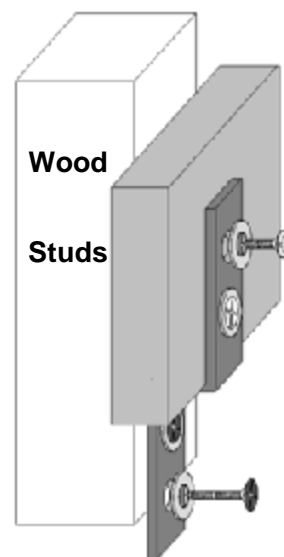
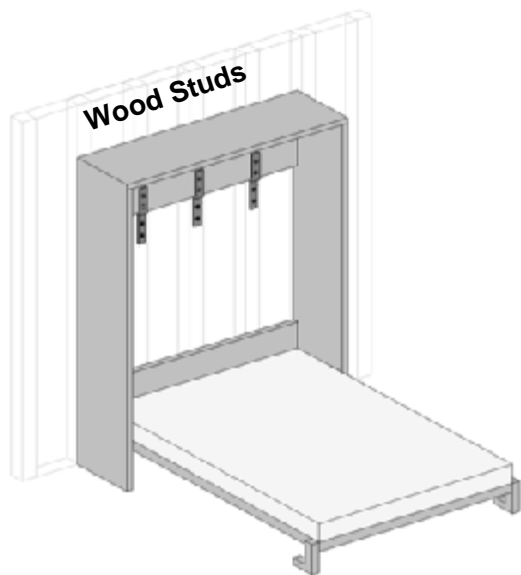

D.) IDENTIFICATION of TOOLS and ATTACHMENT SKILL.

The parts and components to assemble the Bed Frame are stated in the Assembly Instructions. Follow the instructions with attention.

For an efficient assembly, after opening the cartons shipped to you :

- a.) open and layout all parts and components in sequence;
- b.) account for every part, hardware and component;
- c.) then lay out the parts close to each other;

Assemble and tighten each bolt / nut / screw up to 80% to allow for the Bed Frame and Bed Cabinet to be HELD together.

Upon FINAL assembly where all the parts and components are FITTED precisely, in a sequential manner – proceed to tighten each bolt & nut & screw gradually.

CAUTION :

- 1.) The METAL PLATES to the sides of the Side Rails – MUST BE FULLY and SECURELY TIED to the SIDE RAILS.
- 2.) The Piston L-Brackets that are attached to the INNER WALL of the Bed Cabinet – MUST BE FULLY and SECURELY TIED to these Inner Walls.
- 3.) These Metal Plates and the L-Brackets – are the components that are holding the Pistons that allow your Bed to “travel” to an OPEN or CLOSED position.
- 4.) Frequent Inspections of these Metal Plates / Brackets and Pistons Bolts, up to Once a Month – to ascertain these DO NOT BECOME LOOSE. For if these bolts to the Bed Frame and or Bed Cabinet or Pistons are loose, may cause the BED FRAME to become DISLODGED and cause injuries.

REMINDER : NEVER FULLY TIGHTEN any screw / nut or bolt in one session. If you DO TIGHTEN the hardware all the way into the core of the wood, this cause the parts to become skewed that would impact other parts of the item not being able to be aligned to its mounting points for assembly.

E. ALLASSEMBLYWORKS REQUIRESATEAM OF NO LESS THAN 4 ADULTS.

Reminder : Per above info, the cartons and products are heavy – therefore exercise CAUTION at all times and ENSURE YOUR TEAM OF 4 for the entire ASSEMBLY.

F.) ASSEMBLY of BED FRAME.

Identify all parts and components for the Bed Frame.
Assemble the Bed Frame according to the Assembly Instructions.

Upon completion of assembly of the Bed Frame, make a final inspection that all joints and parts are fully and securely attached.

Then place this assembled Bed Frame horizontally flat on the ground, some 10feet away, so as to allow room for the assembly of the Bed Cabinet.

G.) ASSEMBLY OF BED CABINET.

Identify all parts and components for the Bed Cabinet.
Assemble the Bed Cabinet according to the Assembly Instructions.

Upon the completion assembly of the Bed Cabinet, make a final inspection that all joints and parts are fully and securely attached.

CLEAR all debris in the area where your Murphy Bed is going to be attached to the wall.

Move this FULLY ASSEMBLED BED CABINET and position this BED CABINET some 2feet to 3 feet away from the designated Wall, where you have previously made markings.

SAFETY REMINDER – The Cabinet is NOT ATTACHED TO THE WALL, YET. From here on - YOU MUST HAVE 2 ADULT to HOLD and STABILISE this BED CABINET, to prevent the Bed Cabinet from TIPPING OVER.

H. ATTACHMENT OF BED FRAME TO BEDCABINET.

Safety Reminder : DO ENSURE the 2 adult persons holding the Bed Cabinet is IN POSITION ALL THE TIME.

The other 2 adults shall lift and carry the Bed Frame and attach to the L-Bracket – at the inner walls of the Bed Cabinet.

Thereafter, gently LIFT THE Bed Frame to a CLOSED POSITION.

I.) ATTACHMENT OF PISTONS TO HOLD & SUPPORT BED CABINET TO BED FRAME.

The Murphy Bed, is now still placed at 2feet to 3feet, from the wall.

The 2 adults, upon attachment the Bed Frame to the Bed Cabinet, shall get the Pistons, and move to the back of the Murphy Bed. Both persons shall - then attach the Pistons to the Bed Frame and Bed Cabinet.

You may need to – LIGHTLY slide forward-backward to adjust and create gap space so as to enable the Pistons to be hooked to both ends of the hanging bolts in the Inner Wall of the L-BRACKET

Fully Secure and Tighten these Bolts at each end of the Pistons.

J.) Attachment of Safety Latches.

Upon completion of Step I above, ensure the entire structure of Bed Frame to Cabinet is fully and securely attached as ONE UNIT – affix the Safety Latches.

These Latches are to be reachable by Adults Only. Thus, the minimum height shall be no less than 5feet (1.5m) from ground.

K.) POSITIONING THE MURPHY BED INTO ITS FINAL POSITION.

At this juncture, the Murphy Bed is ASSEMBLED BUT NOT AS A FULL & COMPLETE piece of furniture AND NOT FUNCTIONAL AS A BED YET, as it is NOT SECURED TO THE WALL.

DO NOT ATTEMPT TO OPEN THE MURPHY BED AND OR TEST SLEEP AND OR LIE-INTO the Murphy Bed.

ALL 4 (four) adults shall now move the entire Murphy Bed to the FINAL DESIGNATED Position, matching to the previously marked “SCREW-IN” positions in the walls.

L) ATTACHMENT OF MURPHY BED TO WALL.

With the Murphy Bed now in its final designated spot, 2 adult persons shall continue to hold down the entire Murphy Bed.

REMINDER : FOLLOW the INSTRUCTIONS from your Professional Consultant / Contractor.

Position the Ladder (where necessary) and FULLY & SECURELY turn in the BOLTS or SCREWS into the CONCRETE WALL or WOODEN STUDS or STEEL STUDS.

SEQ	Bed Description	Bed Size	Details.
1	Single/Twin(XL)	~38*75/80~ inches	Attach at least 2 pieces of L or Z Hardware onto the Wall or Studs;
2	Full	54*75inches	Install at least 3 pieces of L or Z Hardware onto the Wall or Studs;
3	Queen	60*80inches	Install at least 3 pieces of L or Z Hardware onto the Wall or Studs;
4	King	76*80inches	Install at least 4 pieces of L or Z Hardware onto the Wall or Studs;
5	Other Bed Size		Other Bed Sizes - seek advice from your Contractor

Recommended Mattress weight (77)lb or (35)kg/ Recommended Mattress thickness (6-8)in or (15.2-20.3)cm- Your Murphy Bed is made having taken into consideration the Bed Frame Weight and Mattress weight to pair with the Pistons Newton Force.

Therefore, load your bed with the RECOMMENDED MATTRESS Weights, Size and Thickness as stated here in the assembly instructions.

DO NOT LOAD any heavier and or LARGER and or LIGHTER Mattress than what is recommended here.

M.) MATTRESS PLACEMENT .

Only after the Murphy Bed is FULLY SECURED to the wall, the 2 adult persons who are holding down the entire Murphy Bed, can now be released for this action. Have 1 to 2 persons - place equal strengths to the handles and gently and securely, PULL DOWN the Bed Frame until the Bed Frame is horizontally and level to the ground.

Have the other 2 persons - carry and place the Mattress (**within the recommended weight and thickness**) and gently place the Mattress on to the Bed Frame.

N) PISTON NEWTON-LOAD STRENGTH.

You are hereby reminded that when the BED FRAME is EMPTY OF MATTRESS, the Bed Frame may NEED a STRONGER force to be pulled down before you can place the Mattress.

This RESISTANCE to be PULLED DOWN is a normal characteristics of the Pistons Newton-Load force is “in action”.

O) BED STRAP – GUIDE STRAP

Your Murphy Bed may or may not come equipped with a Bed Strap.

This Bed Strap serves as a GUIDE STRAP to help you lift the Bed Frame some 6 inches or so off its resting position. Then use both hands to FULLY LIFT HOIST the Bed Frame to its closing position.

SAFETY REMINDER :

- 1.) DO NOT USE THE BED STRAP to PULL DOWN TO OPEN the BED FRAME from its CLOSED POSITION.**
- 2.) DO NOT USE THE BED STRAP to PULL-LIFT-HOIST the BED FRAME from the OPENED-HORIZONTAL position, to the CLOSED POSITION.**

Both the above may cause injury and or unnecessary strain to your arm(s).

P.) USING YOUR MURPHY BED.

For EVERY USE – exercising Safety Precautionary Measures to ensure the safety of your family members and pets are IMPORTANT.

Therefore, PRIOR TO OPENING / PRIOR TO CLOSING OF YOUR MURPHY BED - Make sure all Children / Non Ambulatory Persons and Pets are at bay.

KEEP CHILDREN and NON-AMBULATORY persons from Unlatching the Safety Latches.

Q.) CAUTION : DO NOT BE DISTRACTED During EVERY OPENING and CLOSING of your Murphy Bed.

Every time you Pull to OPEN the Murphy Bed from its closed position OR Lift-Pull to CLOSE the Murphy Bed to stow it into the Bed Cabinet -

- give these actions your focused and dedicated attention.
- **DURING EVERY OPENING and CLOSING of your Murphy Bed - always ensure you have an Adult Partner close by for added assistance, where necessary.**
- **DO NOT OVER EXERT ADDED FORCE to OPEN the Bed or to CLOSE the Bedframe.** For if you do, the resistance of the Piston will only make it harder for you to complete the task.
- TO CLOSE the Murphy Bed : depending on your height – stand some 6inches to 10inches away from the FootBoard edge. Use both your hands and place both hands at about equal distance from the middle of the Bed Frame, spaced at 2 to 3 feet between your hands - GENTLY LIFT-PULL to Close your Murphy Bed.
- TO OPEN the Murphy Bed :using equal force –place your hands to the installed grab handle and GENTLY PULL towards you to Open.As you pull Open the Murphy Bed – proceed to move backwards, slowly and steadily,so as to give way to the Murphy Bed's OPEN Position.

- During EVERY OPENING or CLOSING of the Murphy Bed - at about your hip level - you may find that you need to rotate your hand / wrist - take caution here to prevent injury.
- During EVERY OPENING and CLOSING, keep Children and Pets and Non Ambulatory Persons at bay.
- NEVER allow your children to treat this Murphy Bed as a Hide and Seek place of fun or jump on the bed.
- Care & Maintenance - Depending on the frequency of use of your Murphy Bed, it is recommended that you take precautionary Care and Maintenance. It is advisable to conduct NO LESS THAN 2 to 3 checks annually on these mounting points & pistons to ensure that these are securely bolted. Where necessary, use a vacuum cleaner to clear all dust and then wipe down with a damp cloth, then proceed with your maintenance work.

Safety Latches - Your Murphy Bed comes with two (2) Safety Latches. These are to be attached at, both the TOP LEFT and TOP RIGHT hand upper portion, minimum of 5feet (1.5m) from ground, of the Bed Frame / Bed Cabinet. Monitor and Inspect these frequently.

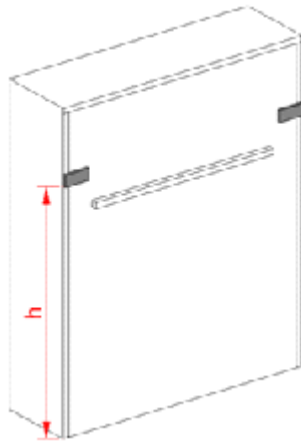

- Whenever NOT in use and after the Murphy Bed has been LIFTED and stowed in its **CLOSED POSITION - ALWAYS LATCH UP.**

Frequently Asked Questions.

Malfunctioned Pistons.

How do you know when the Murphy Bed's Piston has malfunctioned?

It would be quite evident in that :

- a.) the Bed Frame may become **LOPSIDED** and
- b.) the Lift-PULL force to **CLOSE** may be "heavier" than before.

IMMEDIATELY - STOP USING YOUR MURPHY BED.

SEEK and CONSULT professional maintenance service to ascertain the problem and repair and or have the pistons changed.

DOSSIER D'INFORMATIONS IMPORTANTES.

**CE DOSSIER D'INFORMATION CONTIENT DES AVERTISSEMENTS ET
INFORMATIONS SUR LA SÉCURITÉ DU PRODUIT. NE PAS SUIVRE
SANS EXAMINER EN PROFONDEUR.**

A.ÉTIQUETTES D'AVERTISSEMENT.

Votre lit escamotable acheté vous est livré avec des ÉTIQUETTES D'AVERTISSEMENT pour vous le rappeler constamment de prendre et d'adopter des mesures de sécurité tout au long de l'assemblage et des points de montage du lit pour les murs.

NE RETIREZ PAS ces étiquettes

Ces étiquettes d'avertissement servent d'outil de rappel pour les amis et les proches en visite lors de l'utilisation le lit escamotable pour garantir que les précautions de sécurité sont prises.

**WARNING.**

IMPORTANT SAFETY REQUIREMENTS - Bed Attachment to Wall.
For Your Safety, the Murphy Bed MUST BE ATTACHED to the Wall.

Seek Certified Professional Consultant / Contractors for their Services to:

- 1.) DETERMINE the WALL Type in Your Home;
- 2.) PRECISE HARDWARE that suits to the Wall Type in Your Home;
- 3.) INSTALL / ATTACH of the Murphy Bed to the Wall in Your Home;
- 4.) VALIDATE the Murphy Bed is appropriately and securely installed/attached.

The choice of wall anchoring hardware depends on the type of wall. This Murphy Bed is delivered with HARDWARE SCREWS suited for attachment to WOOD STUDS in walls. Any STUDS type detected with your Consultant-Contractors to be **NOT WOOD STUDS** - DISCARD and DO NOT USE these SCREWS. Use the hardware suitable for your wall material.

Seek the professional advice of your Consultant-Contractor and procure the appropriate hardware and brackets for the attachment of the Murphy Bed to the Wall.

FAILURE TO ADHERE TO THE ABOVE INSTRUCTIONS MAY RESULT IN SERIOUS and/or SEVERE INJURIES or Death caused by the detachment of the Murphy Bed from the Wall.

SAFETY PRECAUTION :

1.) MAXIMUM Mattress Weight suited to your Murphy Bed : __lbs (__kg);
MAXIMUM mattress thickness: __ inches (__ cm);
2.) ENSURE ADULTS ONLY throughout the entire assembly and attachment.
3.) KEEP ALL Children, Non-Ambulatory persons and Pets at bay during the entire assembly and attachment.

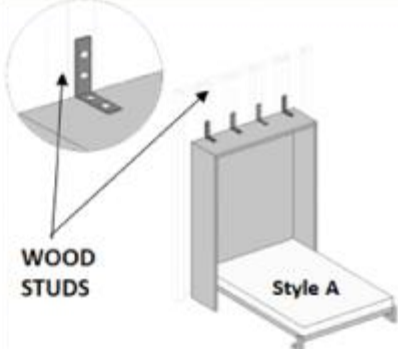

WOOD STUDS

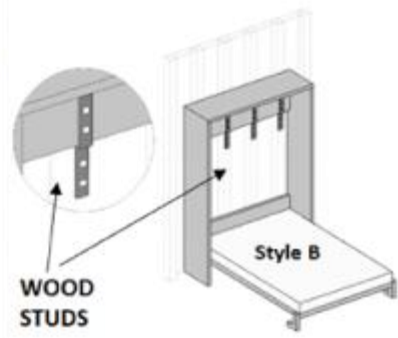

WOOD STUDS

LINE ART for Reference only and NOT DRAWN TO SCALE.

ATTENTION : Les maisons sont rénovées de manière différente. Il existe des murs en **BÉTON** et des **murs creux**. Les murs creux sont renforcés avec des **montants** en matériaux en bois ou en acier. Consultez des professionnels.

Style A - Lit Murphy VERTICAL avec panneau arrière **SCELLÉ/FERMÉ**

Style B - Lit Murphy VERTICAL avec panneau arrière de **STYLE OUVERT**

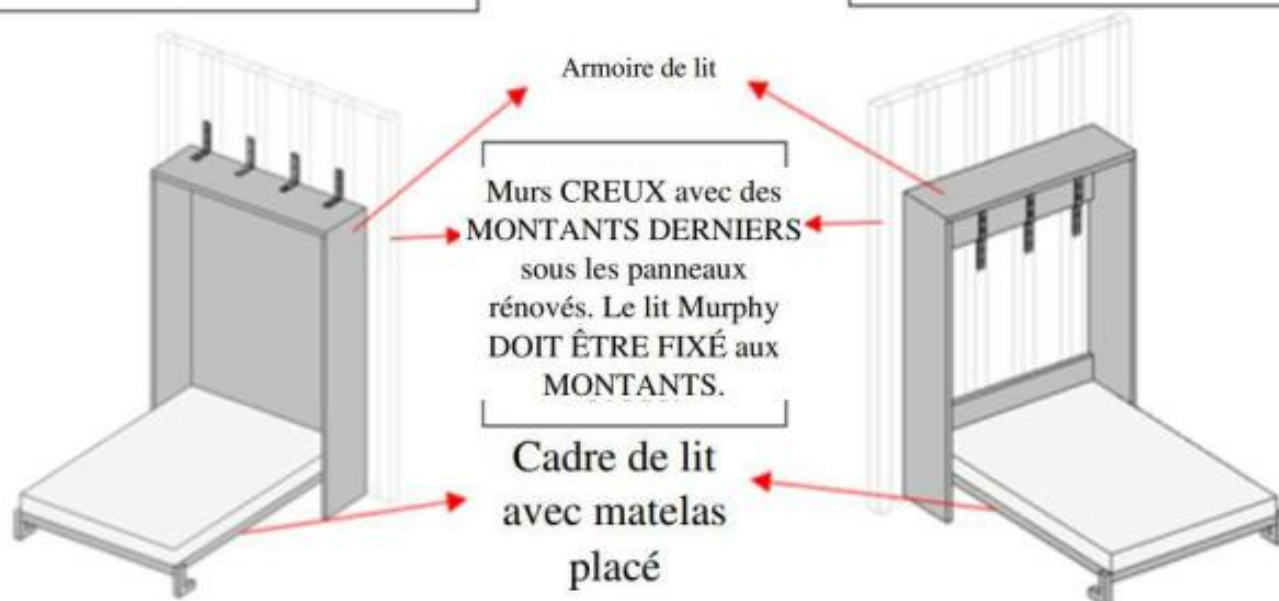

B.) RAPPELS DE SÉCURITÉ. **MARQUAGES sur le MUR – OÙ FIXER le** **LIT MURPHY.**

Quel que soit le type de mur, qu'il s'agisse de murs en béton massif, de murs décoratifs avec des poteaux en bois ou de murs décoratifs avec des poteaux métalliques, assurez-vous que

- a.) vous choisissiez un installateur professionnel qui a une bonne compréhension de la structure du mur où le lit escamotable est ancré, y compris la position des montants muraux et des composants structurels dans le cas d'une structure en bois ou en métal.**
- b.) des marquages précis des positions des points d'ancrage doivent être effectués sur le mur pour une identification facile lors de la fixation du lit escamotable au mur.**
- c.) le matériel pertinent et approprié avec supports métalliques est **PRÊT** pour cette fixation et est facilement accessible pour une fixation rapide et efficace.**

Ce produit nécessite une consultation et une installation professionnelles*.

*Lorsque vous choisissiez l'installateur professionnel, assurez-vous de respecter toutes les lois, réglementations et règles applicables dans la ville, l'état ou le pays où le lit escamotable est installé.

Pour que votre lit escamotable soit entièrement assemblé et pour atteindre sa fonctionnalité prévue, vous DEVEZ LIRE l'intégralité de ce manuel d'instructions d'assemblage avant de commencer l'assemblage du lit.

1.) Il existe de nombreux problèmes de sécurité et mesures de précaution que vous DEVEZ CONNAÎTRE avant de commencer l'assemblage.

2.) ATTENTION - Le non-respect du GUIDE, des AVERTISSEMENTS et des RAPPELS ci-dessous peut entraîner des blessures graves, voire mortelles

3.) PRÉCAUTION : Pour l'assemblage, seuls les partenaires adultes doivent aider à l'assemblage complet. Assurez-vous que 4 (quatre) à 6 (six) PERSONNES CAPABLES SEULEMENT participent à l'assemblage complet et à la fixation de ce lit escamotable aux murs de votre maison.

4.) ATTENTION : Pendant tout le processus d'assemblage et de fixation du lit escamotable aux murs de votre maison, gardez TOUS les enfants, les personnes non ambulateurs et les animaux domestiques complètement à distance

5.) RAPPEL DE SÉCURITÉ concernant : les personnes, les membres de la famille et les animaux de compagnie. Le lit escamotable peut vous être expédié en 3 à 5 colis, lesquels sont LOURDS. Chaque carton contient de nombreuses pièces et composants. Certains de ces composants, comme les boulons et les vis, sont relativement petits*.

*. Pendant le processus d'assemblage, assurez-vous que tous les boulons et écrous mal placés sont ramassés afin que les enfants et/ou les animaux domestiques ne jouent pas avec eux ou ne les ingèrent pas.

6.) Ce lit escamotable est destiné à un USAGE ADULTE UNIQUEMENT.

7.) Ce lit escamotable vous est livré pré-emballé avec du matériel - adapté aux murs à ossature de bois rénovés avec des MONTANTS EN BOIS UNIQUEMENT.

8.) Le type de murs de votre maison - Chaque maison est rénovée différemment, avec des murs et des finitions différents. Avant de commencer l'assemblage de votre lit escamotable :

- a.) RECHERCHER et CONSULTER des services professionnels pour déterminer le type de mur à l'emplacement désigné où vous avez l'intention de fixer le lit escamotable ;
- b.) ASSUREZ-VOUS que le consultant-entrepreneur vous INFORME spécifiquement du TYPE DE MUR à l'endroit désigné où vous avez l'intention de fixer le lit escamotable.
- c.) ASSUREZ-VOUS que le consultant vous INFORME spécifiquement sur le matériel/les supports correspondants et pertinents pour fixer et fixer le lit escamotable au mur.

9.) AVERTISSEMENT – VOUS DEVEZ TENIR COMPTE DES INSTRUCTIONS données par votre consultant-entrepreneur désigné sur

- a.) Type de matériel de montage adapté au type de mur (s) - lorsque les montants ne sont pas en bois, les vis préemballées pour murs à montants en bois ne correspondraient pas.
- b.) Nombre de points de fixation du lit escamotable au mur.

ATTENTION : Les maisons sont rénovées de manière différente. Il existe des murs en **BÉTON** et des **murs creux**. Les murs creux sont renforcés avec des **montants** en matériaux en bois ou en acier. Consultez des professionnels.

Style A - Lit Murphy VERTICAL avec panneau arrière **SCELLÉ/FERMÉ**

Style B - Lit Murphy VERTICAL avec panneau arrière de **STYLE OUVERT**

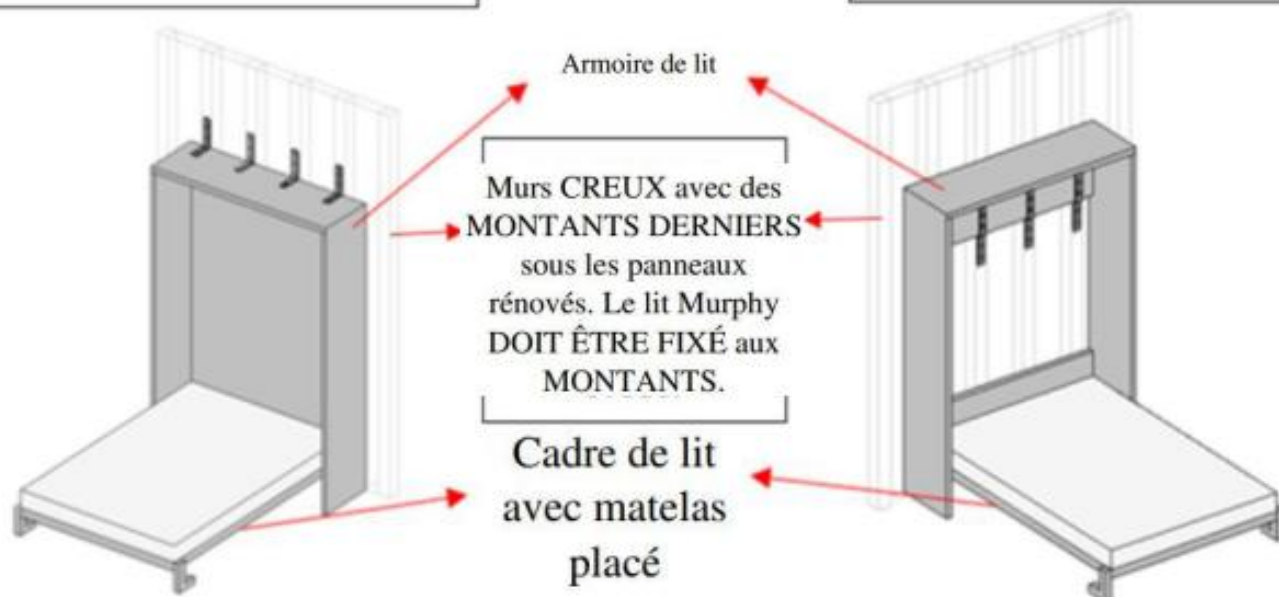

10.) Ce lit escamotable est conçu pour un usage domestique et non destiné à un usage commercial.

11.) Ce lit escamotable n'est pas destiné à être déplacé, modifié, désinstallé ou démonté une fois installé par un professionnel.

C.) INFORMATIONS DE MONTAGE ET MATÉRIEL.

1.) RAPPELS :

- Dans le cas où ce jeu de vis pré-emballé ne correspond pas aux murs de votre maison, N'UTILISEZ PAS / NE JETEZ PAS ce matériel.**
- RESPECTEZ les instructions et les informations du consultant-entrepreneur professionnel sur le matériel de montage PERTINENT qui convient à votre mur.
- L'acquisition de ce matériel PERTINENT est un accord conclu entre votre consultant-contractant et vous.

2.) Un escabeau (non fourni) est nécessaire pour fixer les supports en L au mur, en haut du lit escamotable. Ne vous appuyez pas contre le haut du lit escamotable, car cela pourrait provoquer un affaissement.

Lit escamotable style A

Fixation par support en L sur montants en bois

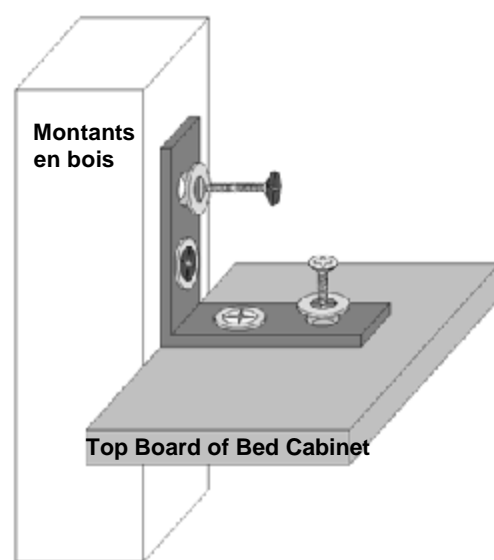
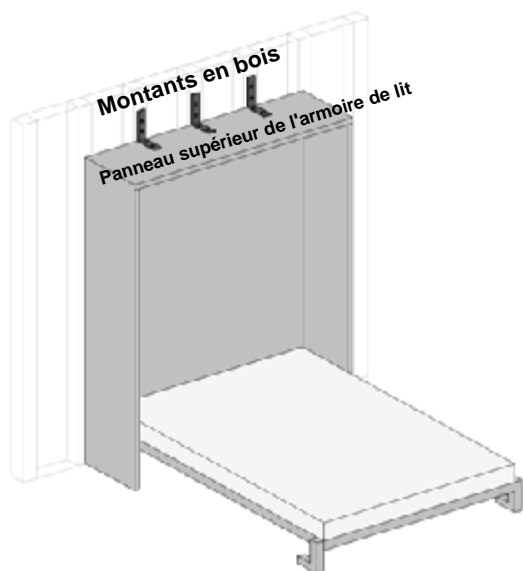

Fixation par support en Z sur montants en bois

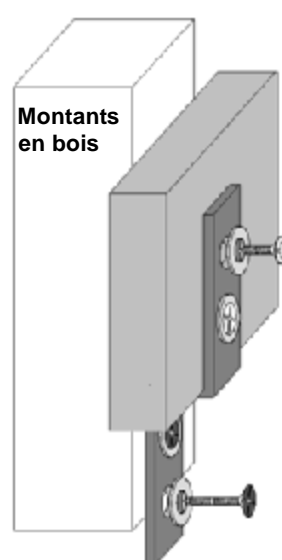
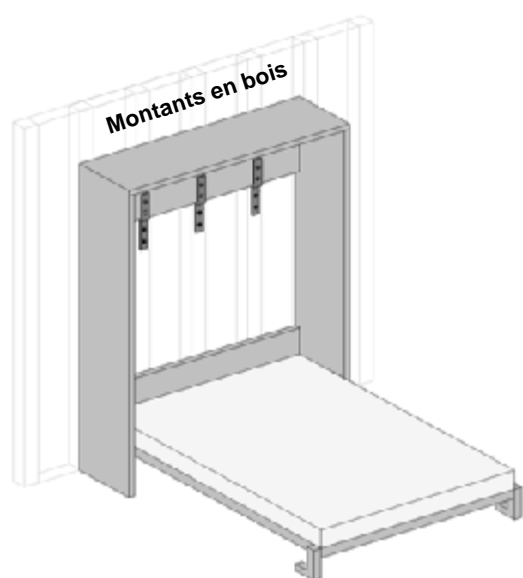

D.) IDENTIFICATION des OUTILS et COMPÉTENCES D'ATTACHEMENT.

Les pièces et composants nécessaires à l'assemblage du cadre de lit sont indiqués dans les instructions de montage. Suivez attentivement les instructions.

Pour un montage efficace, après ouverture des cartons qui vous sont expédiés :

- a.) ouvrir et disposer toutes les pièces et tous les composants en séquence ;
- b.) rendre compte de chaque pièce, matériel et composant ;
- c.) puis disposez les pièces à proximité les unes des autres ;

Assemblez et serrez chaque boulon / écrou / vis jusqu'à 80 % pour permettre au cadre de lit et à l'armoire de lit d'être MAINTENUS ensemble.

Après l'assemblage final, où toutes les pièces et tous les composants sont montés avec précision et de manière séquentielle, serrez progressivement chaque boulon, écrou et vis.

PRUDENCE :

- 1.) Les **PLAQUES MÉTALLIQUES** situées sur les côtés des barrières latérales **DOIVENT ÊTRE COMPLÈTEMENT ET SOLIDEMENT FIXÉES** aux barrières latérales.
- 2.) Les supports en L du piston fixés à la **PAROI INTÉRIEURE** du meuble de lit **DOIVENT ÊTRE FIXÉS ENTIÈREMENT ET SOLIDEMENT** à ces parois intérieures.
- 3.) Ces plaques métalliques et les supports en L sont les composants qui maintiennent les pistons permettant à votre lit de se déplacer vers une position **OUVERTE** ou **FERMÉE**.
- 4.) Inspections fréquentes des plaques métalliques, supports et boulons des pistons, jusqu'à une fois par mois, afin de s'assurer qu'ils **NE SE DESSERRENT PAS**. En effet, si ces boulons sont desserrés, le cadre du lit, le caisson ou les pistons risquent de se détacher et de provoquer des blessures.

RAPPEL : NE SERREZ JAMAIS COMPLÈTEMENT une vis, un écrou ou un boulon en une seule fois. Serrer la visserie jusqu'au cœur du bois peut entraîner un biais des pièces, ce qui empêcherait les autres parties de l'objet de s'aligner sur leurs points de fixation pour l'assemblage.

E.TOUS LES TRAVAUX D'ASSEMBLAGE NÉCESSITENT UNE ÉQUIPE COMPOSÉE D'AU MOINS 4 ADULTES.

Rappel : Conformément aux informations ci-dessus, les cartons et les produits sont lourds. Soyez donc prudents et assurez-vous d'être en équipe de 4 personnes pendant toute la durée du montage.

F.) ASSEMBLAGE DU CADRE DE LIT.

Identifiez toutes les pièces et tous les composants du cadre de lit.
Assemblez le cadre de lit conformément aux instructions de montage.

Une fois l'assemblage du cadre de lit terminé, effectuez une inspection finale pour vous assurer que tous les joints et toutes les pièces sont entièrement et solidement attachés.

Placez ensuite ce cadre de lit assemblé horizontalement à plat sur le sol, à environ 10 pieds de distance, de manière à laisser de la place pour le montage du meuble de lit.

G.) ASSEMBLAGE DE L'ARMOIRE DE LIT.

Identifiez toutes les pièces et tous les composants de l'armoire de lit.
Assemblez le meuble de lit conformément aux instructions de montage.

Une fois l'assemblage du meuble de lit terminé, effectuez une inspection finale pour vérifier que tous les joints et toutes les pièces sont bien en place, sont entièrement et solidement fixés.

NETTOYEZ tous les débris dans la zone où votre lit escamotable sera fixé au mur.

Déplacez ce MEUBLE DE LIT ENTièrement ASSEMBLÉ et positionnez ce MEUBLE DE LIT à environ 2 pieds À 3 pieds du mur désigné, où vous avez déjà fait des marquages.

RAPPEL DE SÉCURITÉ – L'armoire n'est PAS ENCORE FIXÉE AU MUR.
ici - VOUS DEVEZ AVOIR 2 ADULTES pour MAINTENIR et STABILISER ce LIT, pour empêcher le meuble de lit de BASCULER.

H.FIXATION DU CADRE DE LIT AU MEUBLE DE LIT.

Rappel de sécurité : ASSUREZ-VOUS que les 2 adultes tenant le meuble de lit sont EN POSITION TOUT LE TEMPS.

Les 2 autres adultes doivent soulever et porter le cadre du lit et le fixer au support en L – sur les parois intérieures de l'armoire de lit.

Ensuite, SOULEVEZ doucement le cadre du lit jusqu'à une POSITION FERMÉE.

I.) FIXATION DES PISTONS POUR MAINTIEN & SUPPORT DE LIT POUR ARMOIRE AU CADRE DE LIT.

Le lit escamotable est désormais toujours placé à 2 ou 3 pieds du mur.

Après avoir fixé le cadre de lit au meuble, les deux adultes doivent prendre les pistons et se déplacer vers l'arrière du lit escamotable. Ils doivent ensuite fixer les pistons au cadre de lit et au meuble.

Vous devrez peut-être – glisser **LÉGÈREMENT** vers l'avant et vers l'arrière pour ajuster et créer un espace afin de permettre aux pistons d'être accrochés aux deux extrémités des boulons de suspension dans la paroi intérieure du support en L

Fixez et serrez complètement ces boulons à chaque extrémité des pistons.

J.) Fixation des loquets de sécurité.

Une fois l'étape I ci-dessus terminée, assurez-vous que toute la structure du cadre de lit au meuble est entièrement et solidement fixée comme **UNE UNITÉ** – fixez les loquets de sécurité.

Ces loquets doivent être accessibles uniquement aux adultes. La hauteur minimale du sol doit donc être d'au moins 1,5 m.

K.) POSITIONNEMENT DU LIT MURPHY DANS SA POSITION DÉFINITIVE.

À ce stade, le lit escamotable est assemblé, mais pas comme un meuble complet et pas encore fonctionnel comme un lit, car il n'est pas fixé au mur.

N'ESSAYEZ PAS D'OUVRIER LE LIT ESCAMOTABLE, DE TESTER LE SOMMEIL ET DE VOUS ALLONGER DANS LE LIT ESCAMOTABLE.

Les 4 (quatre) adultes doivent maintenant déplacer l'ensemble du lit escamotable vers la position **DÉSIGNÉE FINALE**, correspondant aux positions « **VISSÉES** » précédemment marquées dans les murs.

L) FIXATION DU LIT ESCAMOTABLE AU MUR.

Une fois le lit escamotable installé à son emplacement définitif, deux adultes doivent continuer à le maintenir en place.

RAPPEL : SUIVEZ les INSTRUCTIONS de votre conseiller/entrepreneur professionnel.

Positionnez l'échelle (si nécessaire) et vissez solidement les boulons ou les vis dans le mur en béton, les poteaux en bois ou les poteaux en acier.

SEQ	Descriptions du lit	Taille du lit	Détails
1	Single/Twin(XL)	~38*75/80~ inches	fixez au moins 2 pièces de matériel en L ou en Z sur le mur ou les montants ;
2	Full	54*75inches	fixez au moins 3 pièces de matériel en L ou en Z sur le mur ou les montants ;
3	Queen	60*80inches	fixez au moins 3 pièces de matériel en L ou en Z sur le mur ou les montants ;
4	King	76*80inches	fixez au moins 4 pièces de matériel en L ou en Z sur le mur ou les montants ;
5	Autres tailles de lit		Autres tailles de lit - demandez conseil à votre entrepreneur.

Poids du matelas recommandé : (77 lb ou (35 kg) / Épaisseur du matelas recommandée : (6-8 po ou (15,2-20,3 cm) - Votre lit escamotable est fabriqué en tenant compte du poids du cadre de lit et du matelas, en fonction de la force Newton des pistons.

Par conséquent, chargez votre lit avec les matelas dont le poids, la taille et l'épaisseur sont recommandés, comme indiqué dans les instructions de montage.

Ne chargez pas de matelas plus lourd, plus grand ou plus léger que ce qui est recommandé ici.

M.) PLACEMENT DU MATELAS.

Une fois le lit escamotable solidement fixé au mur, les deux adultes qui le maintiennent peuvent être libérés.

Demandez à une ou deux personnes d'exercer une force égale sur les poignées et de tirer doucement et fermement le cadre du lit vers le bas jusqu'à ce qu'il soit horizontal et au niveau du sol.

Demandez aux deux autres personnes de porter et de placer le matelas (en respectant le poids et l'épaisseur recommandés) et de le placer délicatement sur le cadre du lit.

N) RÉSISTANCE À LA CHARGE NEWTON DU PISTON.

Nous vous rappelons que lorsque le cadre de lit est vide de matelas, il peut être nécessaire d'exercer une force de traction plus importante avant de pouvoir y placer le matelas. Cette résistance à la traction est une caractéristique normale des pistons, la force de Newton étant « active ».

O) SANGLE DE LIT – SANGLE DE GUIDAGE

Votre lit escamotable peut être équipé ou non d'une sangle de lit.

Cette sangle de lit sert de guide pour vous aider à soulever le cadre de lit d'environ 15 cm de sa position de repos. Utilisez ensuite vos deux mains pour soulever complètement le cadre de lit jusqu'à sa position fermée.

RAPPEL DE SÉCURITÉ :

- 1.) N'UTILISEZ PAS LA SANGLE DE LIT POUR TIRER VERS LE BAS POUR OUVRIR le CADRE DE LIT depuis sa POSITION FERMÉE.**
- 2.) N'UTILISEZ PAS LA SANGLE DE LIT POUR TIRER, SOULEVER ET HISSER le CADRE DE LIT de la position OUVVERTE-HORIZONTALE à la POSITION FERMÉE.**

Les deux éléments ci-dessus peuvent entraîner des blessures ou une tension inutile sur votre ou vos bras.

P.) UTILISATION DE VOTRE LIT MURPHY.

Pour CHAQUE UTILISATION – il est IMPORTANT de prendre des mesures de précaution pour assurer la sécurité des membres de votre famille et de vos animaux de compagnie.

Par conséquent, AVANT D'OUVRIR / AVANT DE FERMER VOTRE LIT ESCAMOTABLE -

Assurez-vous que tous les enfants / personnes non ambulatoires et animaux domestiques sont à distance.

EMPÊCHEZ LES ENFANTS et les personnes NON AMBULATOIRES de déverrouiller les loquets de sécurité.

Q.) ATTENTION : NE VOUS LAISSEZ PAS DISTRAIRE pendant CHAQUE OUVVERTURE et FERMETURE de votre lit escamotable.

Chaque fois que vous tirez pour OUVRIR le lit escamotable depuis sa position fermée OU que vous soulevez-tirez pour FERMER le lit escamotable pour le ranger dans l'armoire à lit

- accordez à ces actions votre attention concentrée et dévouée.
- **À CHAQUE OUVVERTURE et FERMETURE de votre lit escamotable, assurez-vous toujours d'avoir un partenaire adulte à proximité pour une assistance supplémentaire, si nécessaire.**
- **N'EXERCEZ PAS UNE FORCE SUPPLÉMENTAIRE POUR OUVRIR le lit ou FERMER le cadre. Sinon, la résistance du piston ne fera que compliquer la tâche.**
- POUR FERMER le lit escamotable : selon votre taille, tenez-vous à environ 15 à 25 cm du bord du pied de lit. Utilisez vos deux mains et placez-les à égale distance du milieu du cadre de lit, espacées de 60 à 90 cm. Soulevez et tirez doucement pour fermer votre lit escamotable.
- **POUR OUVRIR le lit escamotable : en utilisant une force égale, placez vos mains sur la poignée de maintien installée et TIREZ DOUCEMENT vers vous pour ouvrir. Pendant que vous tirez pour ouvrir le lit escamotable, continuez à reculer, lentement et régulièrement, afin de laisser passer la position OUVVERTE du lit escamotable.**

- À CHAQUE OUVERTURE ou FERMETURE du lit escamotable - à peu près au niveau de vos hanches - vous constaterez peut-être que vous devez faire pivoter votre main / poignet - soyez prudent ici pour éviter les blessures.
- À CHAQUE OUVERTURE et FERMETURE, tenez les enfants, les animaux domestiques et les personnes non ambulateurs à distance.
- NE JAMAIS permettre à vos enfants de traiter ce lit escamotable comme un lieu de cache-cache amusant ou de sauter sur le lit.
- Entretien et maintenance - Selon la fréquence d'utilisation de votre lit escamotable, il est recommandé d'effectuer des précautions d'entretien et de maintenance. Il est conseillé d'effectuer au moins 2 à 3 vérifications par an des points de fixation et des pistons afin de s'assurer qu'ils sont bien fixés. Si nécessaire, utilisez un aspirateur pour éliminer toute la poussière, puis essuyez avec un chiffon humide, puis procédez à l'entretien.

Loquets de sécurité - Votre lit escamotable est équipé de deux (2) loquets de sécurité. Ceux-ci doivent être fixés en haut à gauche et en haut à droite du cadre de lit, à au moins 1,5 m du sol. Surveillez-les et inspectez-les régulièrement.

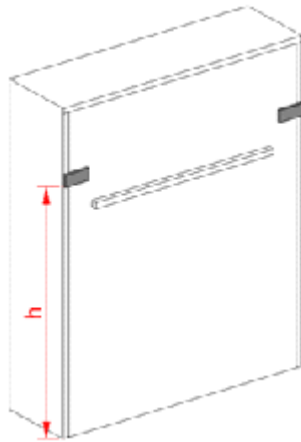

- Lorsqu'il n'est PAS utilisé et après que le lit escamotable a été SOULEVE et rangé en POSITION FERMÉE - TOUJOURS VERROUILLER.

Foire aux questions. Pistons défectueux.

Comment savoir si le piston du lit escamotable est défectueux ?

Cela serait assez évident dans la mesure où

a.) le cadre de lit peut devenir DÉSÉQUILIBRÉ et

B.) la force de levage-traction pour FERMER peut être « plus lourde » qu'avant.

IMMÉDIATEMENT - ARRÊTEZ D'UTILISER VOTRE LIT MURPHY.

CHERCHEZ et CONSULTEZ un service d'entretien professionnel pour déterminer le problème et réparer et/ou faire changer les pistons. et/ou faire changer les pistons.

OPTION 1

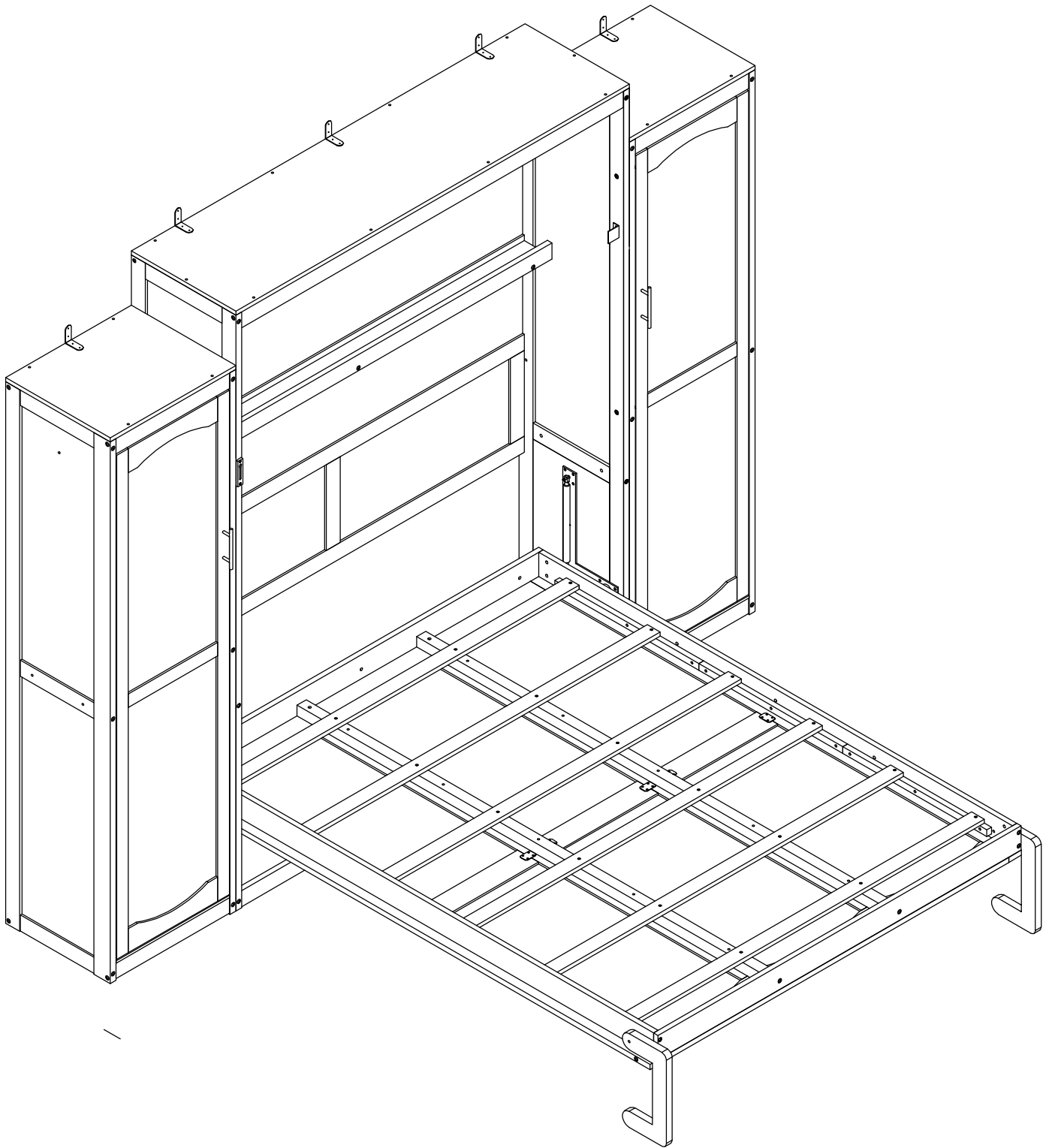

OPTION 2

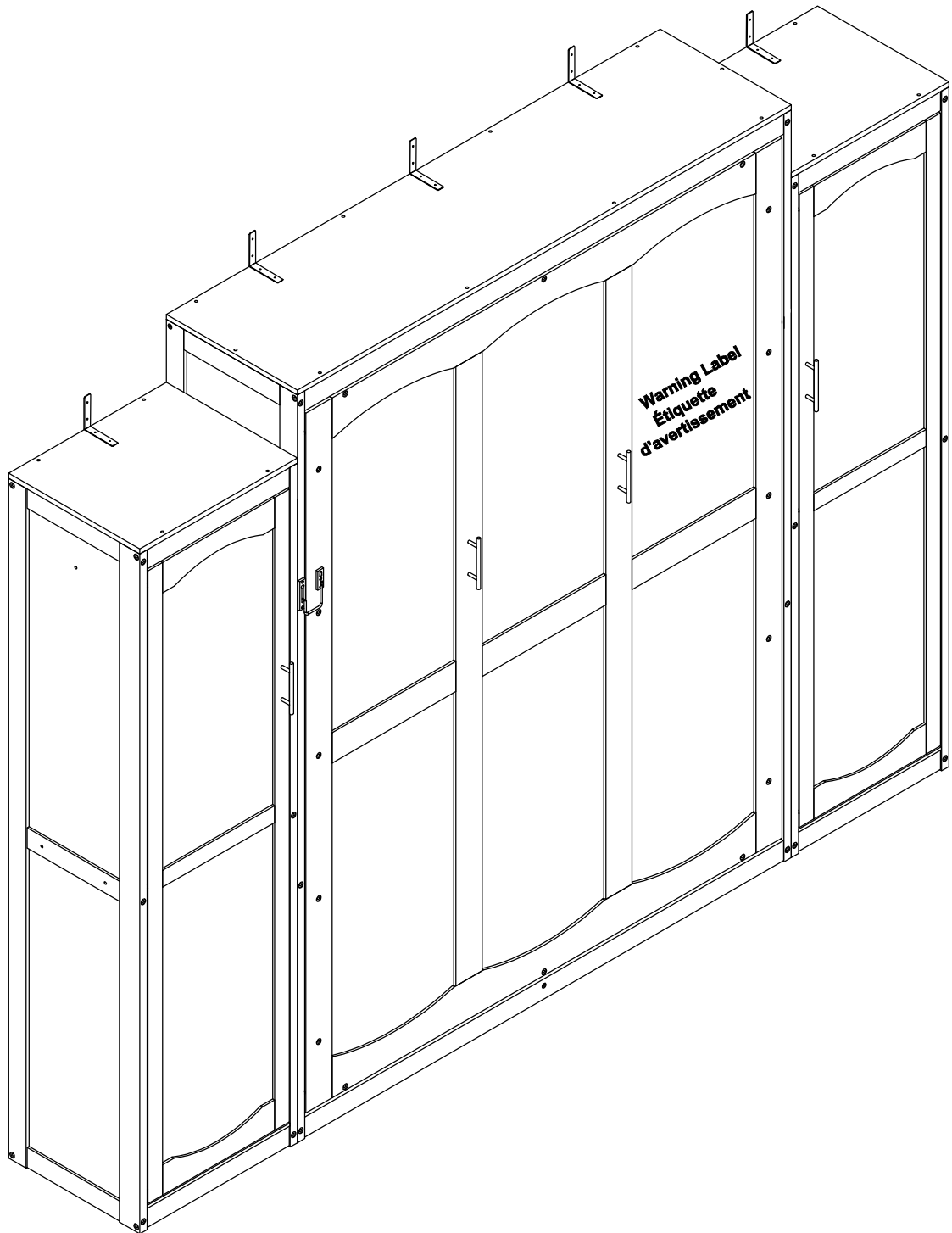

ASSEMBLY INSTRUCTION

INSTRUCTIONS DE MONTAGE

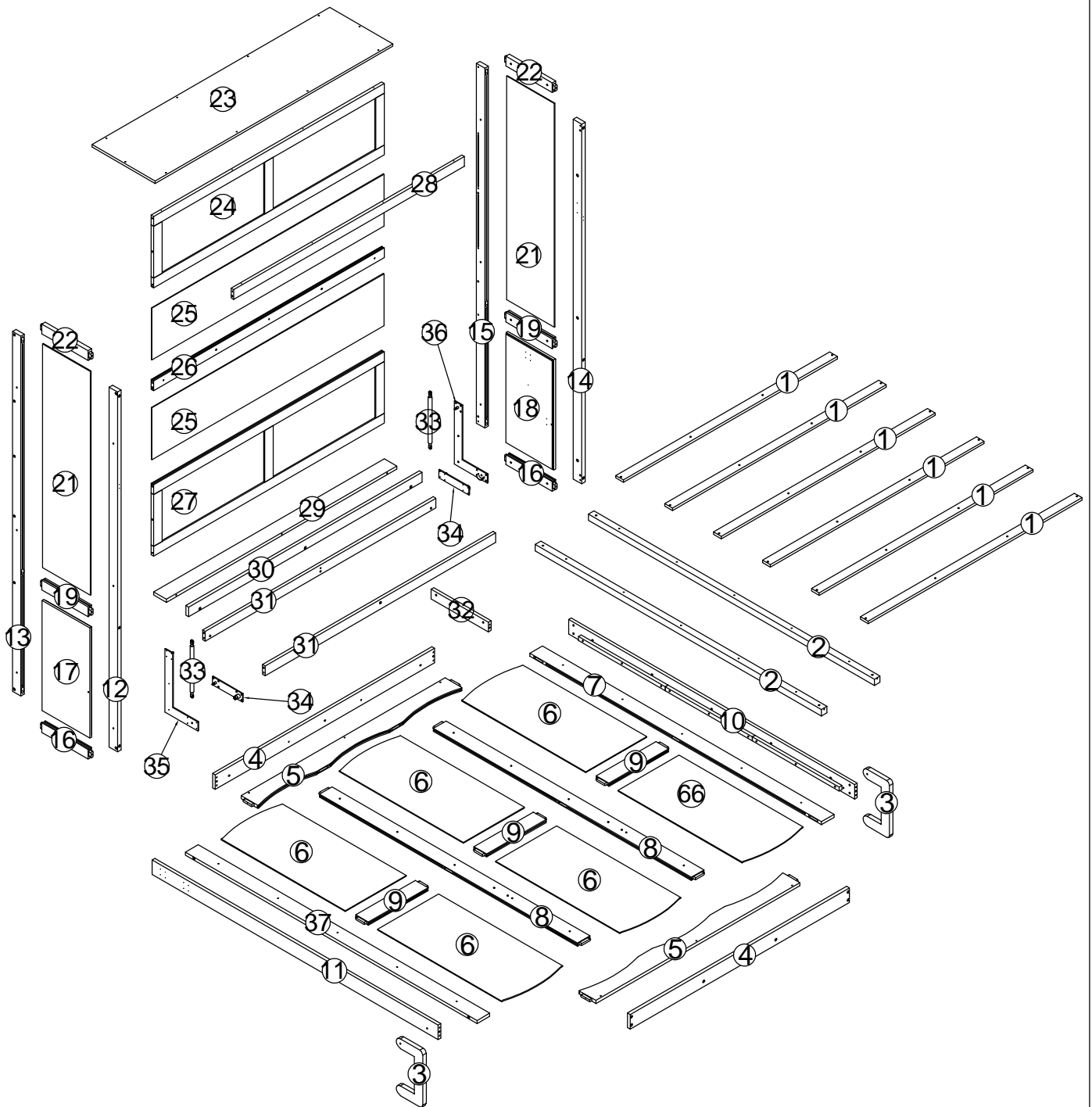





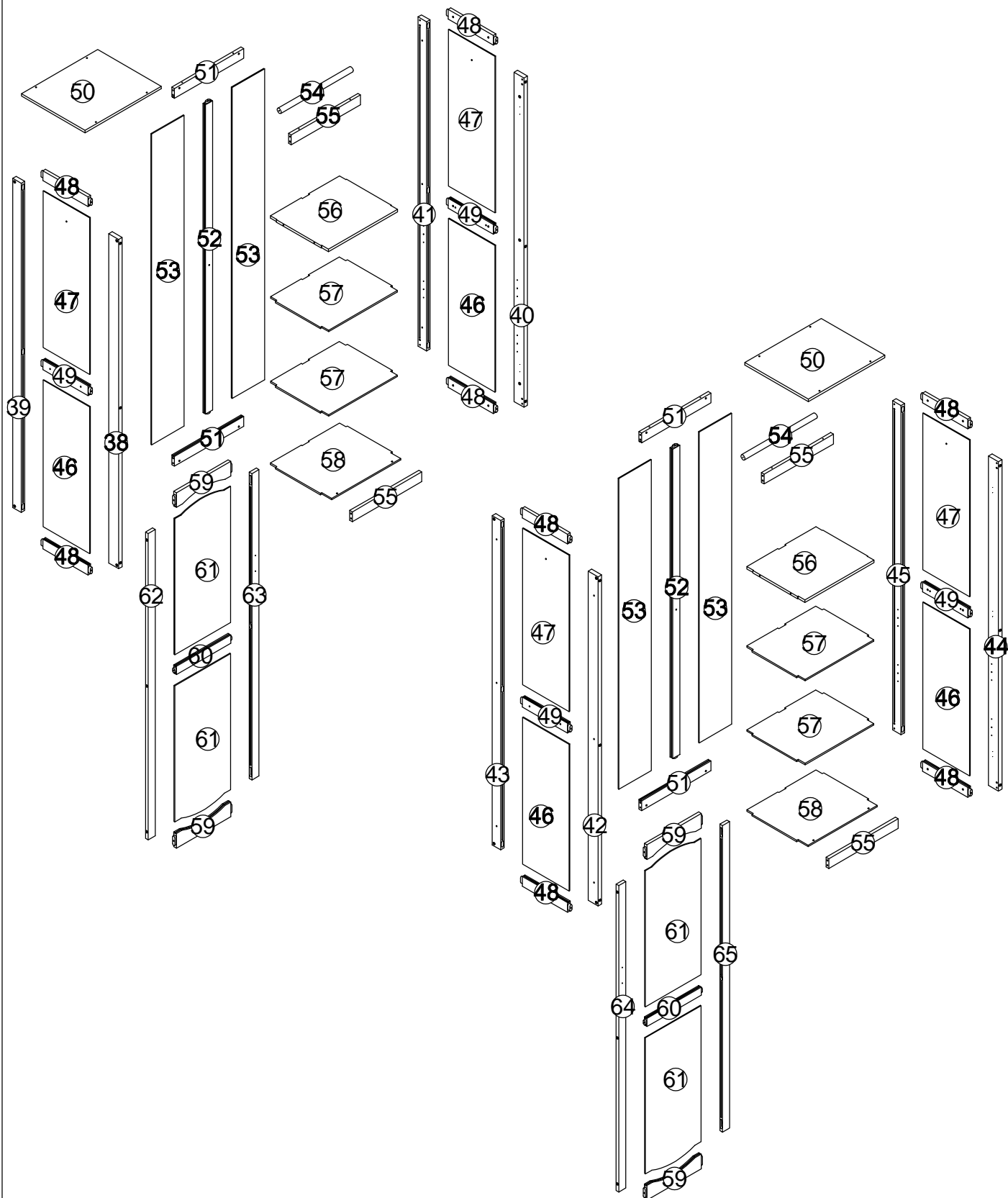





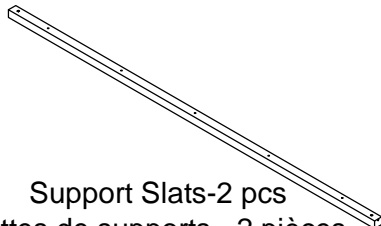

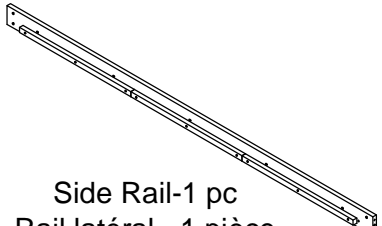
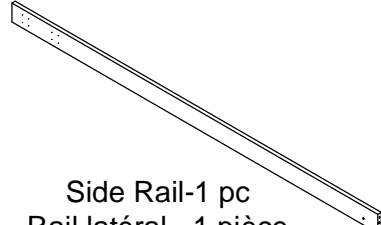
ASSEMBLY INSTRUCTION

INSTRUCTIONS DE MONTAGE

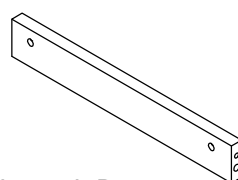





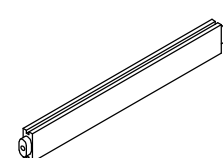





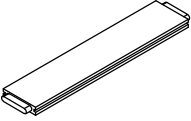
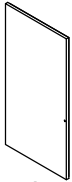
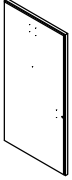

Part List

Liste des pièces

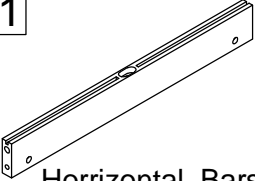
<p>2</p>  <p>Support Slats-2 pcs Lattes de supports - 2 pièces</p>	<p>7</p>  <p>Wood Bar-1 pc Barres de boi - 1 pièce</p>	<p>10</p>  <p>Side Rail-1 pc Rail latéral - 1 pièce</p>
<p>11</p>  <p>Side Rail-1 pc Rail latéral - 1 pièce</p>	<p>12</p>  <p>Vertical Bar-1 pc Barre verticale - 1 pièce</p>	<p>13</p>  <p>Vertical Bar-1 pc Barre verticale - 1 pièce</p>
<p>14</p>  <p>Vertical Bar-1 pc Barre verticale - 1 pièce</p>	<p>15</p>  <p>Vertical Bar-1 pc Barre verticale - 1 pièce</p>	<p>32</p>  <p>Horizontal Bar-1 pc Barres horizontale - 1 pièce</p>
<p>37</p>  <p>Wood Bar-1 pc Barres de boi - 1 pièce</p>	<p>39</p>  <p>Vertical Bar-1 pc Barre verticale - 1 pièce</p>	<p>41</p>  <p>Vertical Bar-1 pc Barre verticale - 1 pièce</p>
<p>43</p>  <p>Vertical Bar-1 pc Barre verticale - 1 pièce</p>	<p>45</p>  <p>Vertical Bar-1 pc Barre verticale - 1 pièce</p>	<p>53</p>  <p>Back Panels-4 pcs Panneaux arrière - 4 pièces</p>
<p>60</p>  <p>Door-Horizontal Bars-2 pcs Barres horizontales de porte- 2 pièces</p>		

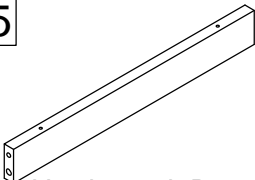
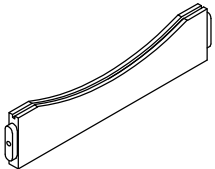

Part List

Liste des pièces

<p>8</p>  <p>Wood Bars-2 pcs Barres de bois - 2 pièces</p>	<p>9</p>  <p>Wood Bars-3 pcs Barres de bois - 3 pièces</p>	<p>17</p>  <p>Panel-1 pc Panneaux-1 pièce</p>
<p>18</p>  <p>Panel-1 pc Panneaux-1 pièce</p>	<p>38</p>  <p>Vertical Bar-1 pc Barre verticale - 1 pièce</p>	<p>40</p>  <p>Vertical Bar-1 pc Barre verticale - 1 pièce</p>
<p>42</p>  <p>Vertical Bar-1 pc Barre verticale - 1 pièce</p>	<p>44</p>  <p>Vertical Bar-1 pc Barre verticale - 1 pièce</p>	<p>46</p>  <p>Panels-4 pcs Panneaux-4 pièces</p>
<p>47</p>  <p>Panels-4 pcs Panneaux-4 pièces</p>	<p>51</p>  <p>Horizontal Bars-4 pcs Barres horizontales - 4 pièces</p>	<p>52</p>  <p>Vertical Bars-2 pcs Barre verticales - 2 pièces</p>
<p>55</p>  <p>Horizontal Bars-4 pcs Barres horizontales - 4 pièces</p>	<p>59</p>  <p>Door-Horizontal Bars-4 pcs Barres horizontales de porte- 4 pièces</p>	<p>62</p>  <p>Door-Vertical Bar-1 pc Porte-Barre Verticale-1 pièce</p>
<p>63</p>  <p>Door-Vertical Bar-1 pc Porte-Barre Verticale-1 pièce</p>	<p>64</p>  <p>Door-Vertical Bar-1 pc Porte-Barre Verticale-1 pièce</p>	<p>65</p>  <p>Door-Vertical Bar-1 pc Porte-Barre Verticale-1 pièce</p>

Part List

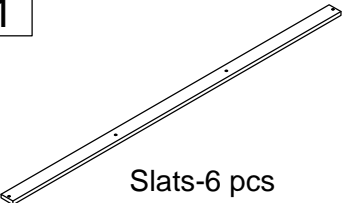
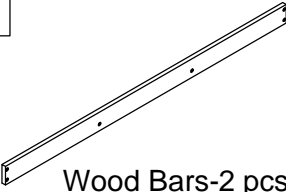
Liste des pièces

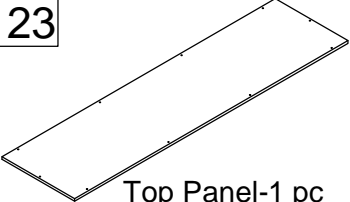
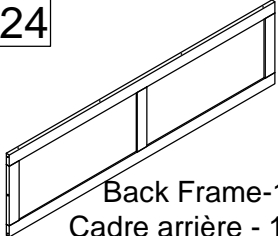
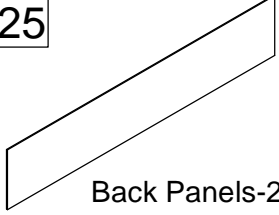
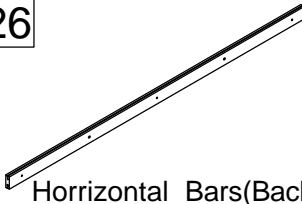
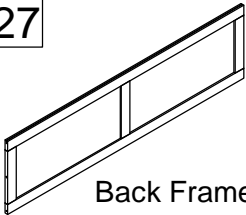
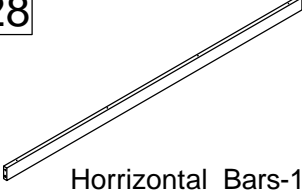
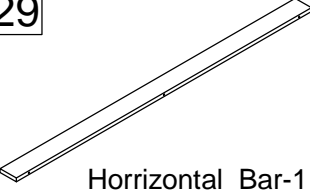
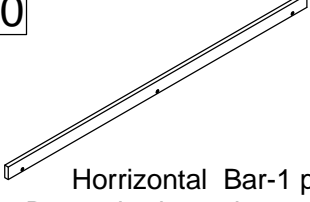
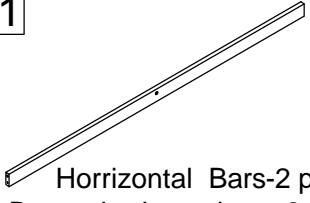
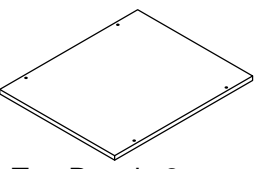
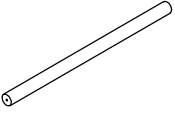
<p>1</p>  <p>Slats-6 pcs Lattes-6 pièces</p>	<p>4</p>  <p>Wood Bars-2 pcs Barres de bois - 2 pièces</p>	<p>5</p>  <p>Wood Bars-2 pcs Barres de bois - 2 pièces</p>
<p>21</p>  <p>Panels-2 pcs Panneaux-2 pièces</p>	<p>23</p>  <p>Top Panel-1 pc Panneau supérieur - 1 pièce</p>	<p>24</p>  <p>Back Frame-1 pc Cadre arrière - 1 pièce</p>
<p>25</p>  <p>Back Panels-2 pcs Panneaux arrière - 2 pièces</p>	<p>26</p>  <p>Horizontal Bars(Back)-1 pc Barres horizontales (arrière) - 1 pièce</p>	<p>27</p>  <p>Back Frame-1 pc Cadre arrière - 1 pièce</p>
<p>28</p>  <p>Horizontal Bars-1 pc Barres horizontales - 1 pièce</p>	<p>29</p>  <p>Horizontal Bar-1 pc Barres horizontale - 1 pièce</p>	<p>30</p>  <p>Horizontal Bar-1 pc Barres horizontale - 1 pièce</p>
<p>31</p>  <p>Horizontal Bars-2 pcs Barres horizontales - 2 pièces</p>	<p>50</p>  <p>Top Panels-2 pcs Panneaux supérieurs - 2 pièces</p>	<p>54</p>  <p>Horizontal Bars-2 pcs Barres horizontales - 2 pièces</p>

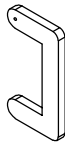
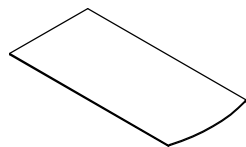
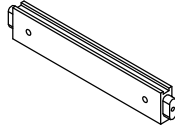
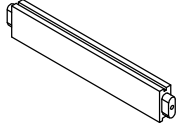
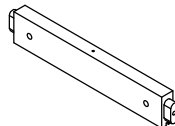
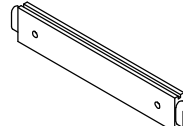
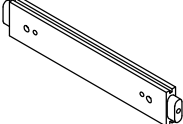
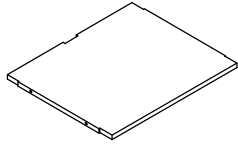
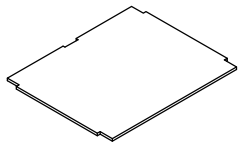
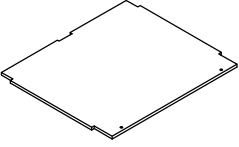
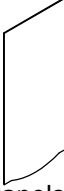
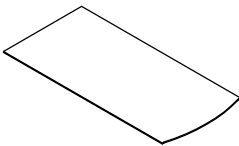

Part List

Liste des pièces

<p>3</p>  <p>Legs-2 pcs Jambes-2 pièces</p>	<p>6</p>  <p>Panels-5 pcs Panneaux-5 pièces</p>	<p>16</p>  <p>Horizontal Bars-2 pcs Barres horizontales - 2 pièces</p>
<p>19</p>  <p>Horizontal Bars-2 pcs Barres horizontales - 2 pièces</p>	<p>22</p>  <p>Horizontal Bars-2 pcs Barres horizontales - 2 pièces</p>	<p>48</p>  <p>Horizontal Bars-8 pcs Barres horizontales - 8 pièces</p>
<p>49</p>  <p>Horizontal Bars-4 pcs Barres horizontales - 4 pièces</p>	<p>56</p>  <p>Panels-2 pcs Panneaux-2 pièces</p>	<p>57</p>  <p>Remove Panels-4 pcs Retirer les panneaux - 4 pièces</p>
<p>58</p>  <p>Bottom Panels-2 pcs Panneaux inférieurs - 2 pièces</p>	<p>61</p>  <p>Door-Panels-4 pcs Panneaux de porte - 4 pièces</p>	<p>66</p>  <p>Panel-1 pc Panneaux-1 pièce</p>



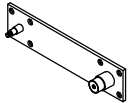
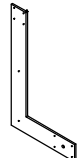

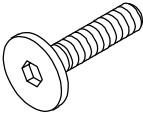
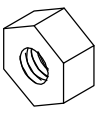

Box Of Piston System

Système de boîte à pistons

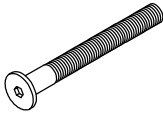
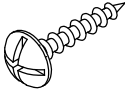
<p>33</p>  <p>Pistons-2 pcs Pistons - 2 pièces</p>	<p>34</p>  <p>Steel Brackets-2 pcs Support en aciers - 2 pièces</p>	<p>35</p>  <p>Steel Bracket-1 pc Support en acier - 1 pièce</p>
<p>36</p>  <p>Steel Bracket-1 pc Support en acier - 1 pièce</p>	<p>V</p>  <p>Bearing-2 pcs Bearing - 2 pièces</p>	<p>X</p>  <p>Bolt Ø8 x40 mm -2 pcs Boulon Ø8 x40 mm -2 pièces</p>
<p>U</p>  <p>Nuts-4 pcs Noix - 4 pièces</p>		

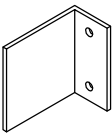
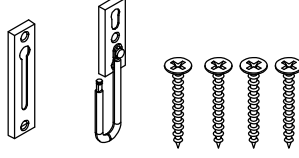
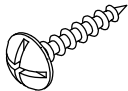
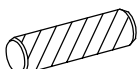
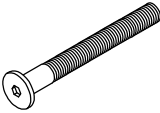
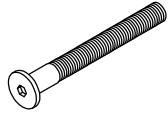
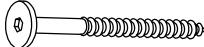

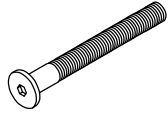
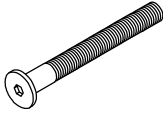
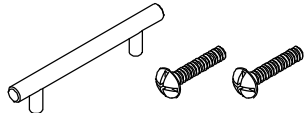

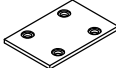
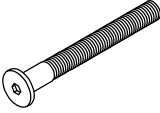
Hardware List

Liste du matériel

<p>A</p>  <p>Ø6 x 13 mm-98 pcs Ø6 x 13 mm-98 pièces</p>	<p>B</p>  <p>Bolt Ø6 x110 mm -36 pcs Boulon Ø6 x110 mm -36 pièces</p>	<p>C</p>  <p>Screws-M4 x 20mm-64 pcs Vis-M4 x 20mm-64 pièces</p>
<p>D</p>  <p>Screws-M4 x 30mm-24 pcs Vis-M4 x 30mm-24 pièces</p>	<p>E</p>  <p>Stop Bed-2 pcs Stop Bed-2 pièces</p>	<p>F</p>  <p>Lock-1 set Serrure -1 jeux</p>
<p>G</p>  <p>Screws Ø4 x 15 mm-58 pcs Vis Ø4 x 15 mm-58 pièces</p>	<p>H</p>  <p>Wood dowel Ø10 x 40 mm-36 pcs Cheville en bois Ø10 x 40 mm-36 pièces</p>	<p>K</p>  <p>Bolt Ø6 x70 mm -46 pcs Boulon Ø6 x70 mm -46 pièces</p>
<p>L</p>  <p>Bolt Ø6 x30 mm -16 pcs Boulon Ø6 x30 mm -16 pièces</p>	<p>M</p>  <p>Screws Ø6x40 mm -18 pcs Vis Ø6x40 mm -18 pièces</p>	<p>N</p>  <p>Screws Ø6x110 mm -4 pcs Vis Ø6x110 mm -4 pièces</p>
<p>P</p>  <p>Bolt Ø6 x75 mm -16 pcs Boulon Ø6 x75 mm -16 pièces</p>	<p>Q</p>  <p>Bolt Ø6 x55 mm -10 pcs Boulon Ø6 x55 mm -10 pièces</p>	<p>R</p>  <p>Handle -4 set Poignées - 4 jeux</p>
<p>S</p>  <p>Plastic washer -2 pcs Rondelle en plastique - 2 pièces</p>	<p>T</p>  <p>Steel Bracket-6 pcs Support en acier - 6 pièces</p>	<p>Y</p>  <p>Bolt Ø6 x40 mm -14 pcs Boulon Ø6 x40 mm -14 pièces</p>

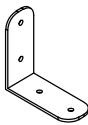
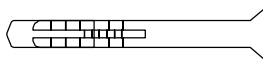
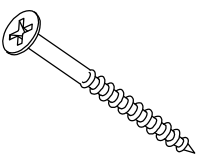
Hardware List

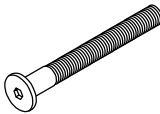
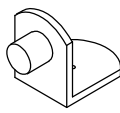
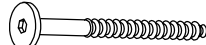

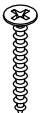
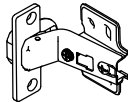
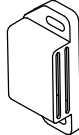
Liste du matériel

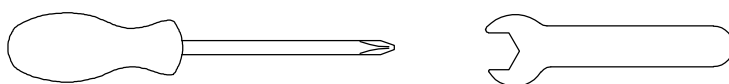
<p>Z</p>  <p>Ø6 x 15 mm-14 pcs Ø6 x 15 mm-14 pièces</p>	<p>W</p>  <p>Steel Bracket-5 pcs Support en acier - 5 pièces</p>	<p>AA</p>  <p>Plastic stopper-10 pcs Bouchon en plastique - 10 pièces</p>
<p>AB</p>  <p>Screws-M5 x 80mm-10 pcs Vis-M5 x 80mm-10 pièces</p>	<p>AC</p>  <p>Allen Key -1pc Clé Allen - 1 pièce</p>	<p>AD</p>  <p>Bolt Ø6 x20 mm -4 pcs Boulon Ø6 x20 mm -4 pièces</p>
<p>AE</p>  <p>Steel dowel -16 pcs Cheville en acier - 16 pièces</p>	<p>AF</p>  <p>Screws Ø6x70 mm -16 pcs Vis Ø6x70 mm -16 pièces</p>	<p>AG</p>  <p>Magnetic Leaf -4 pcs Feuille magnétique - 4 pièces</p>
<p>AH</p>  <p>Screws-M3.5 x 12mm-8 pcs Vis-M3.5 x 12mm-8 pièces</p>	<p>AK</p>  <p>Hinge-6 pcs Charnière - 6 pièces</p>	<p>AL</p>  <p>Magnetic -4 pcs Magnétique - 4 pièces</p>

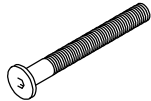

Assembly Tools Required (Not Included)
Outils d'assemblage requis (non inclus)

STEP 1-1:
ÉTAPE 1-1:

	Ø6x110mm	Ø6x13 mm
		
ACx1	Bx3	Ax3

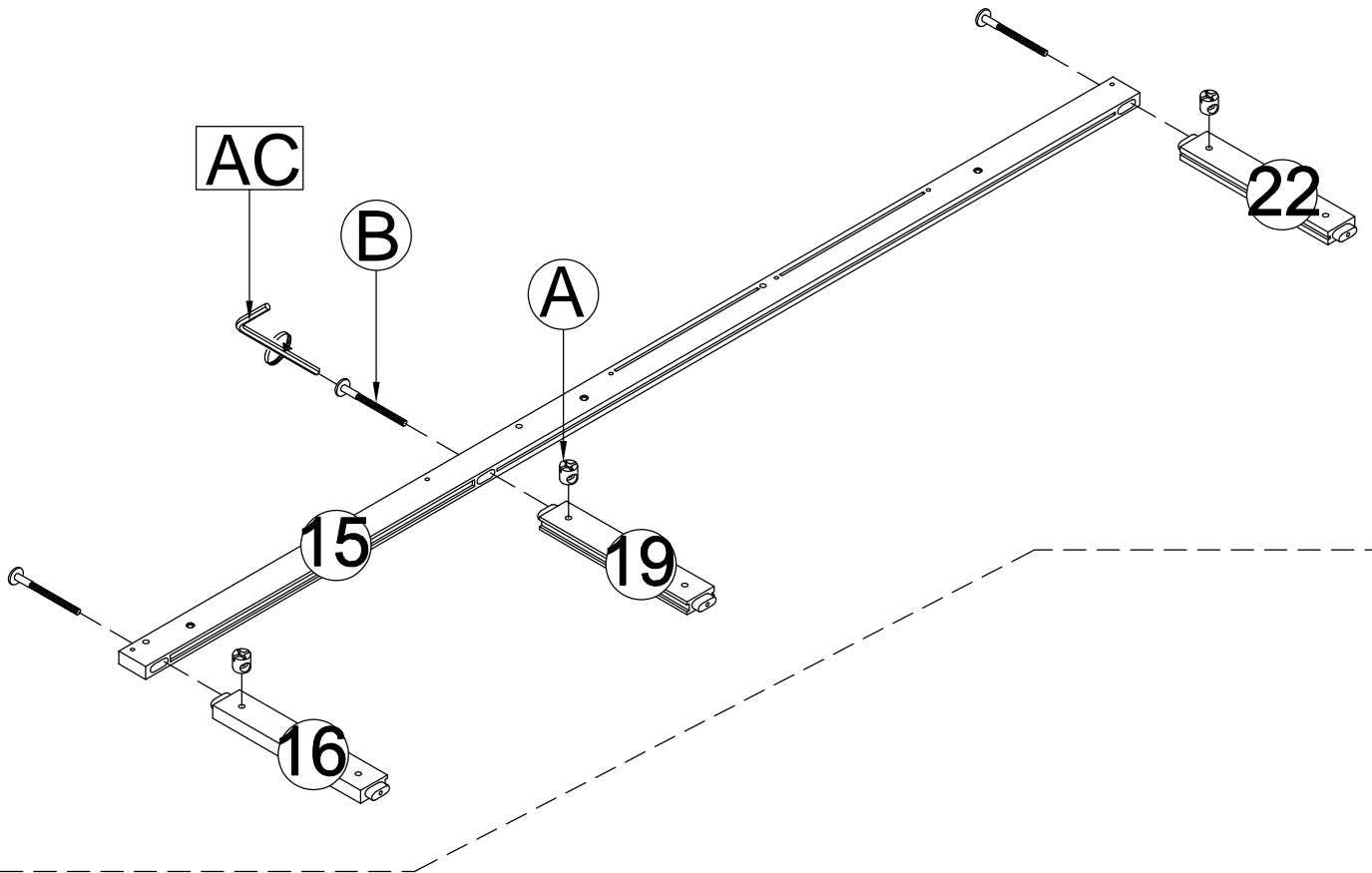

STEP 1-2:
ÉTAPE 1-2:

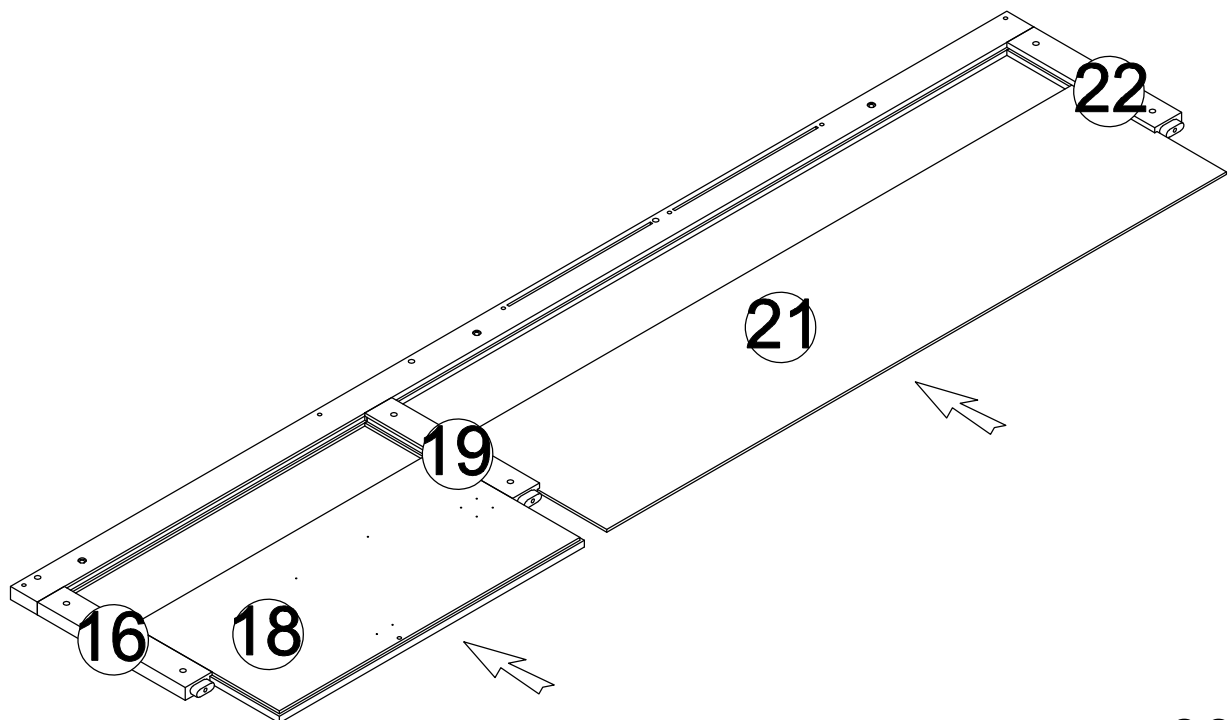

STEP 1-3:
ÉTAPE 1-3:

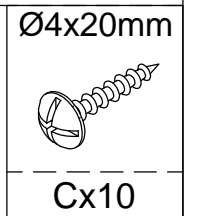
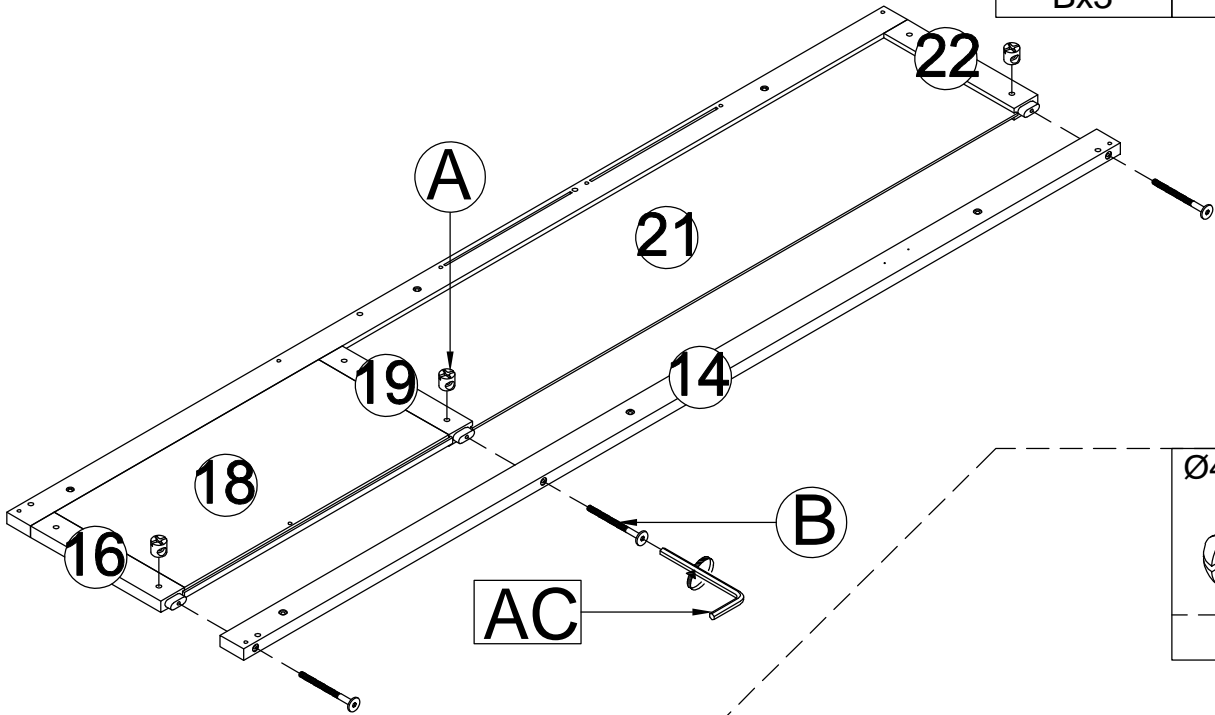
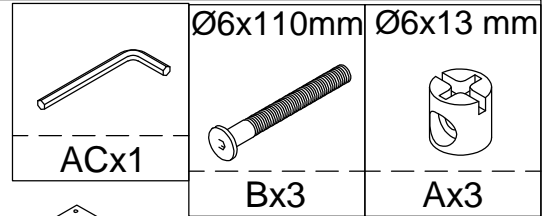

STEP 1-4:
ÉTAPE 1-4:

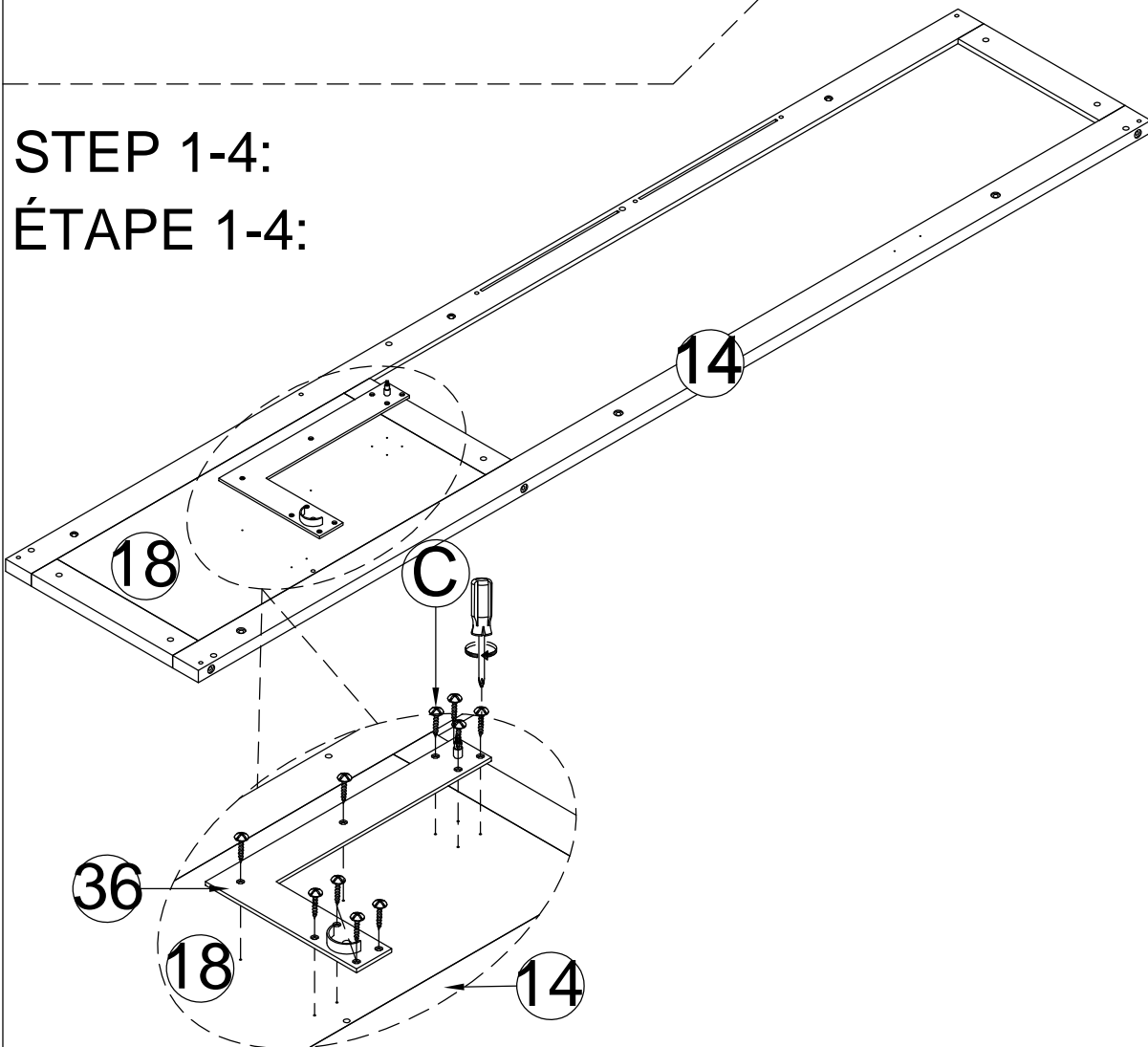

STEP 2-1:
ÉTAPE 2-1:

	Ø6x110mm	Ø6x13 mm
ACx1	Bx3	Ax3

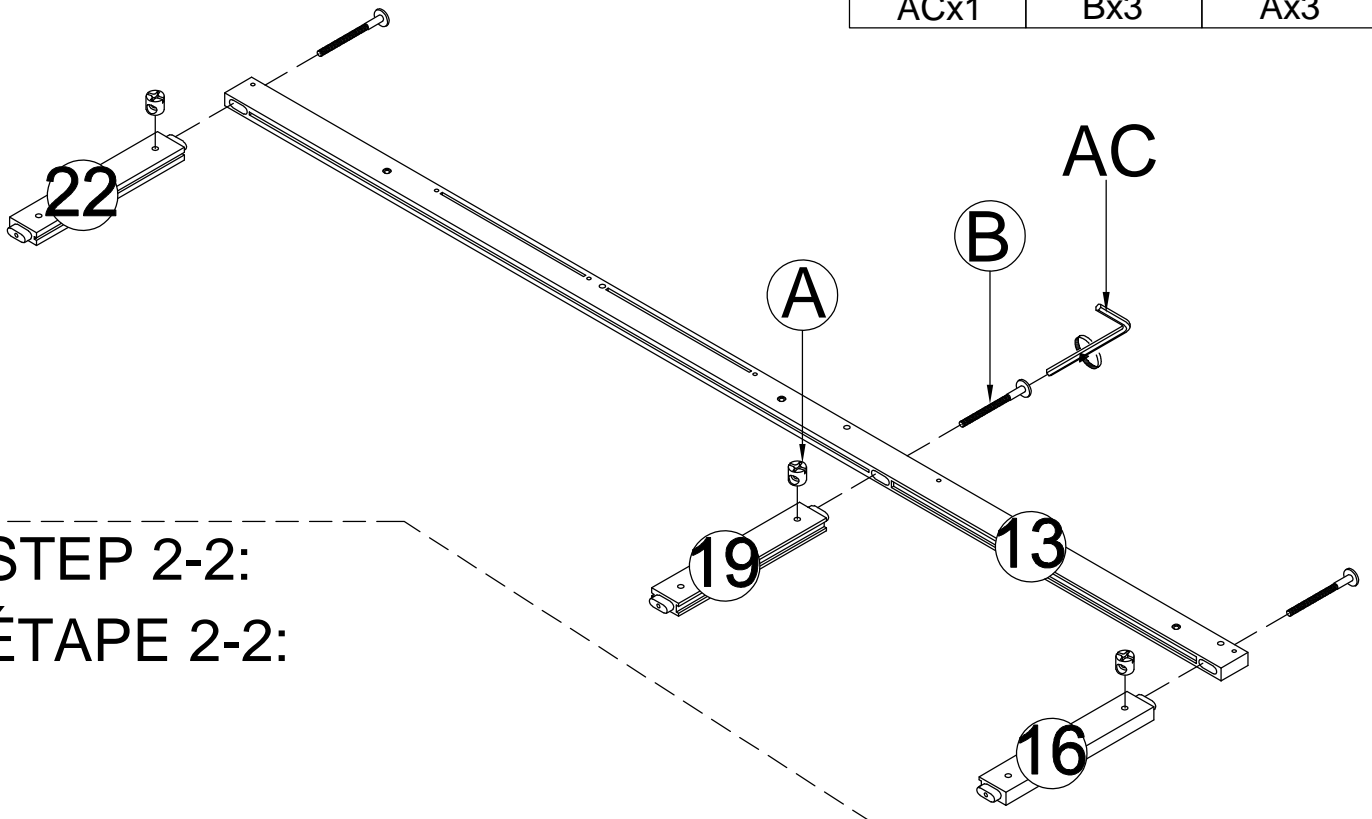

STEP 2-2:
ÉTAPE 2-2:

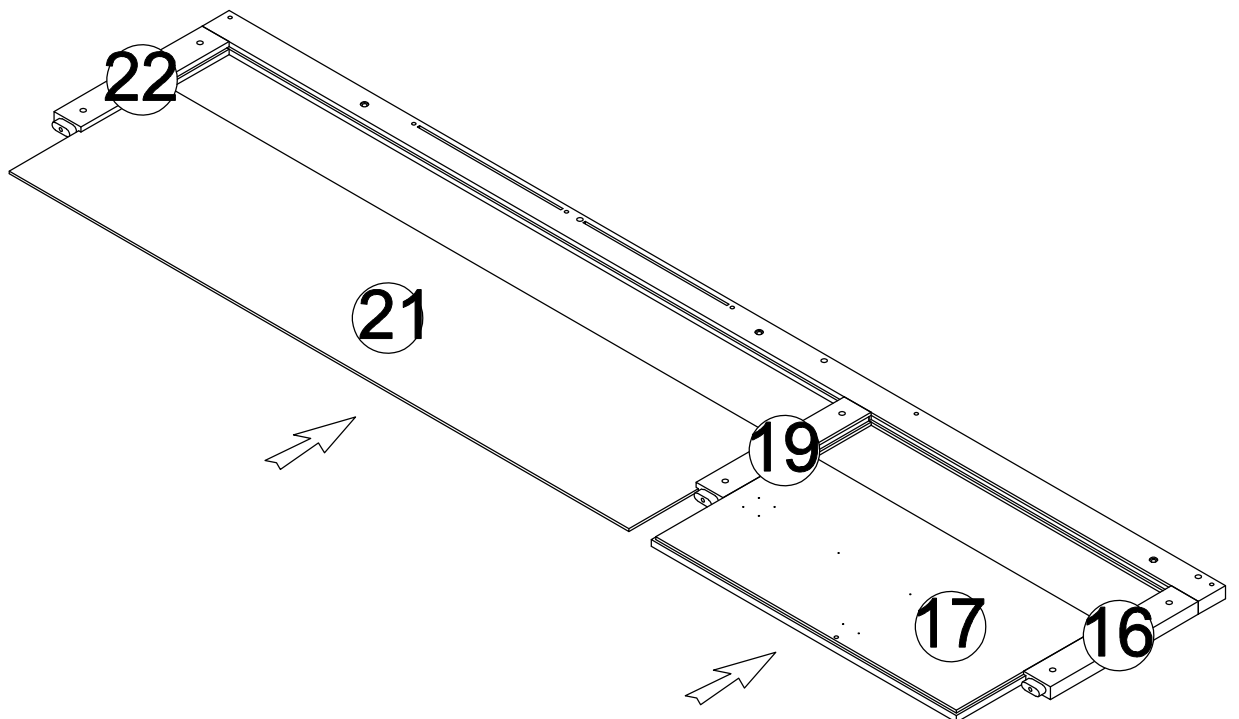

STEP 2-3:

ÉTAPE 2-3:

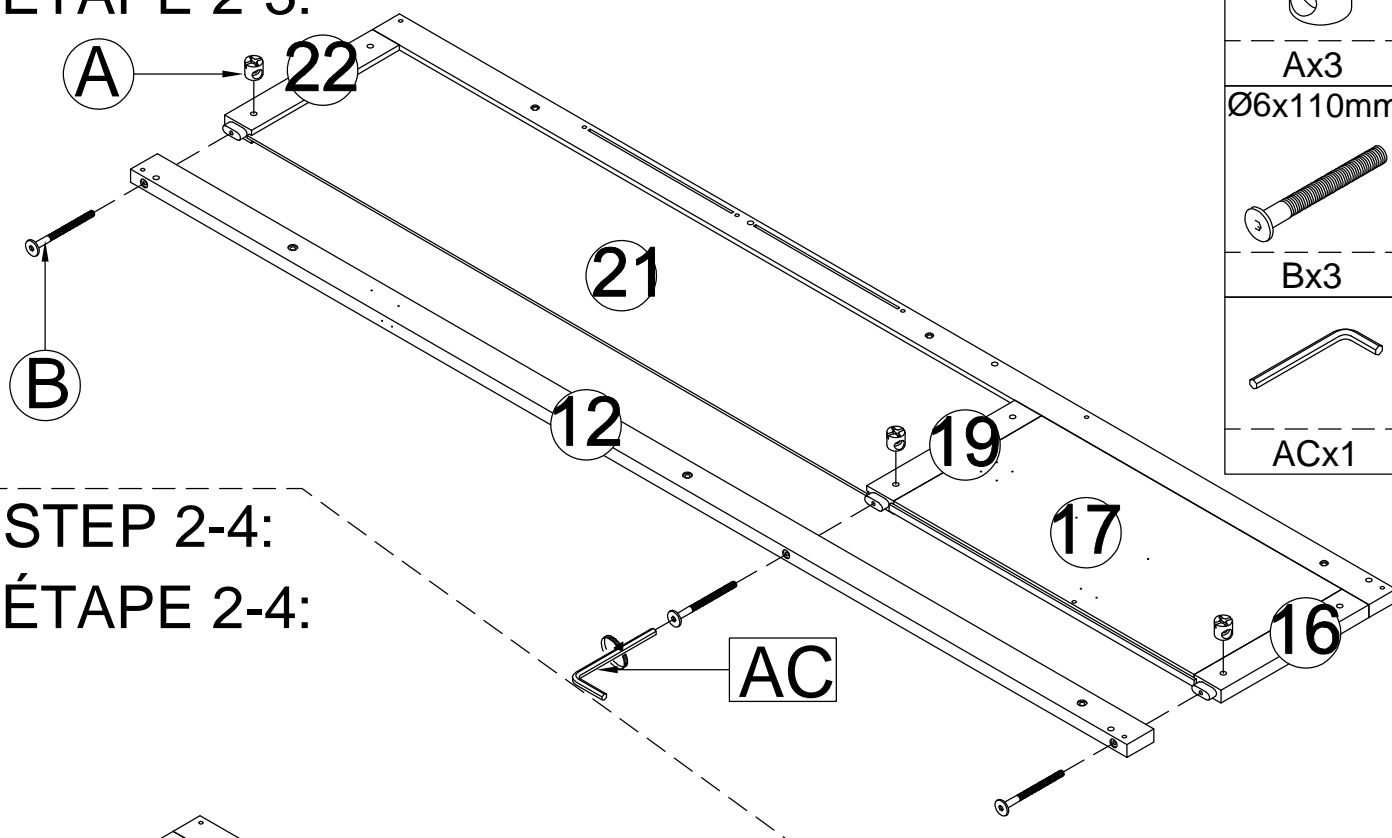

Ø6x13 mm



Ax3

Ø6x110mm

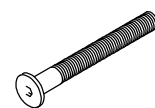

Bx3



ACx1

STEP 2-4:

ÉTAPE 2-4:

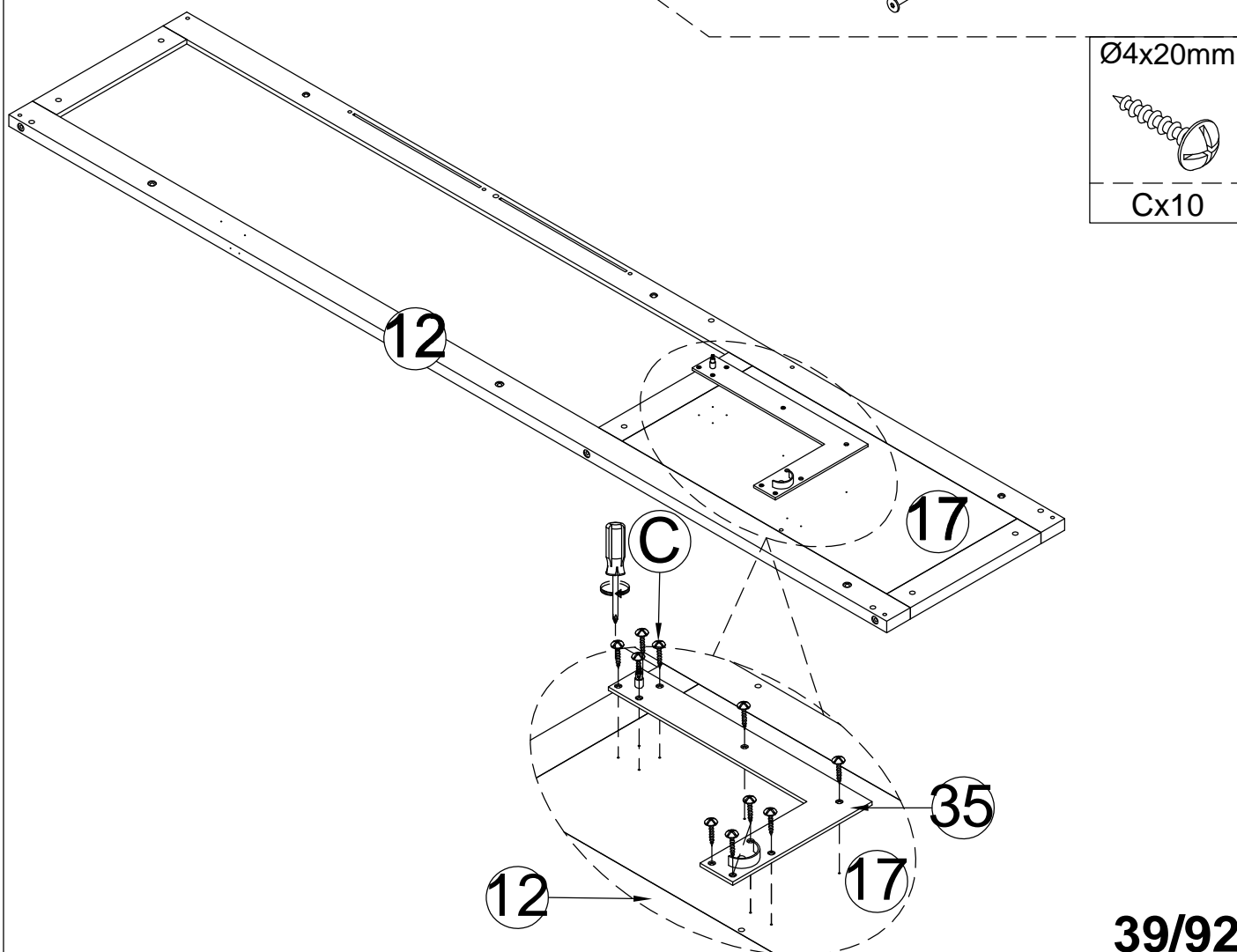

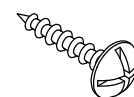

Ø4x20mm



Cx10

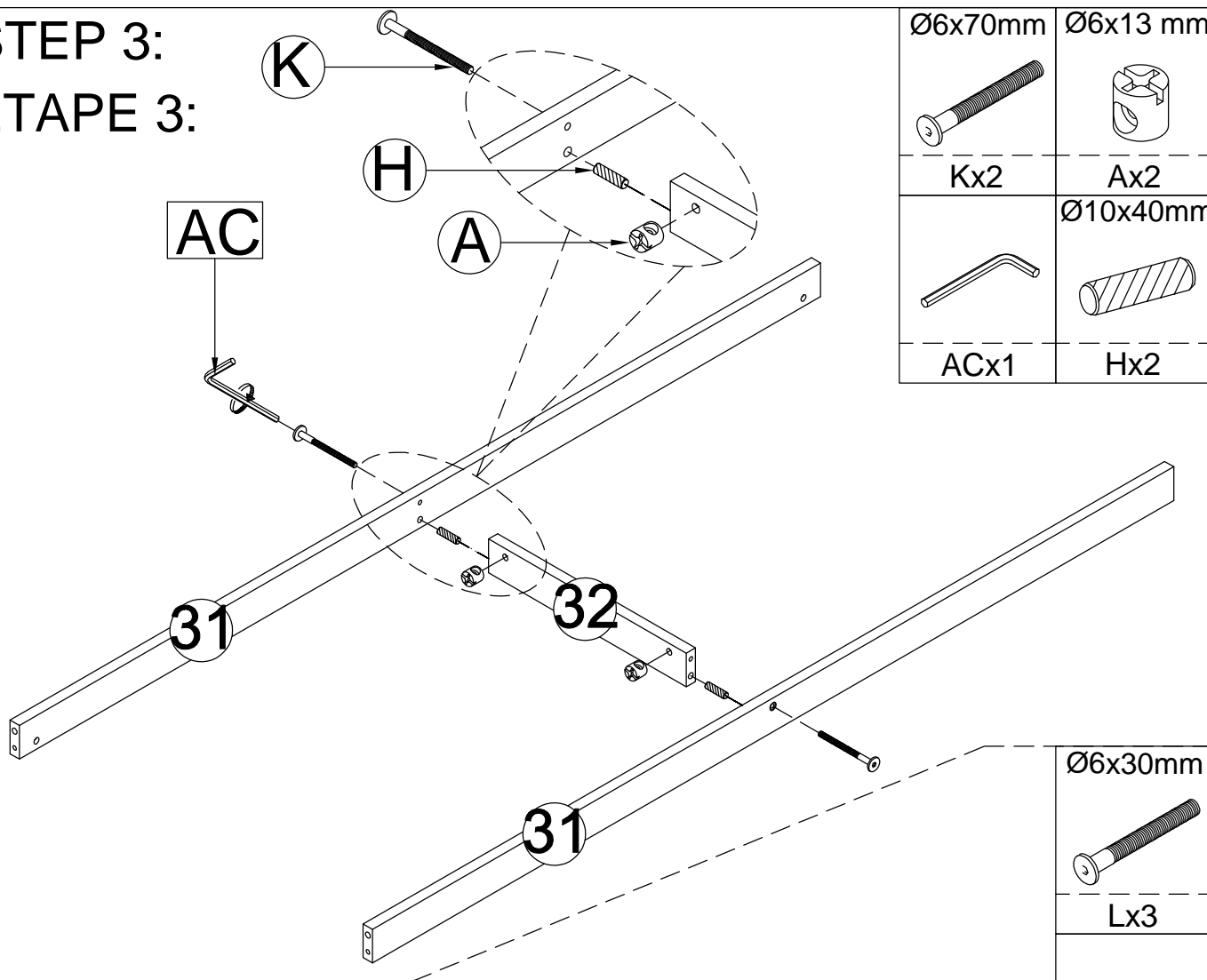

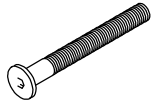
STEP 3:
ÉTAPE 3:

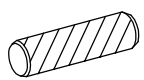

Ø6x70mm	Ø6x13 mm
	
Kx2	Ax2
	Ø10x40mm
ACx1	
	Hx2

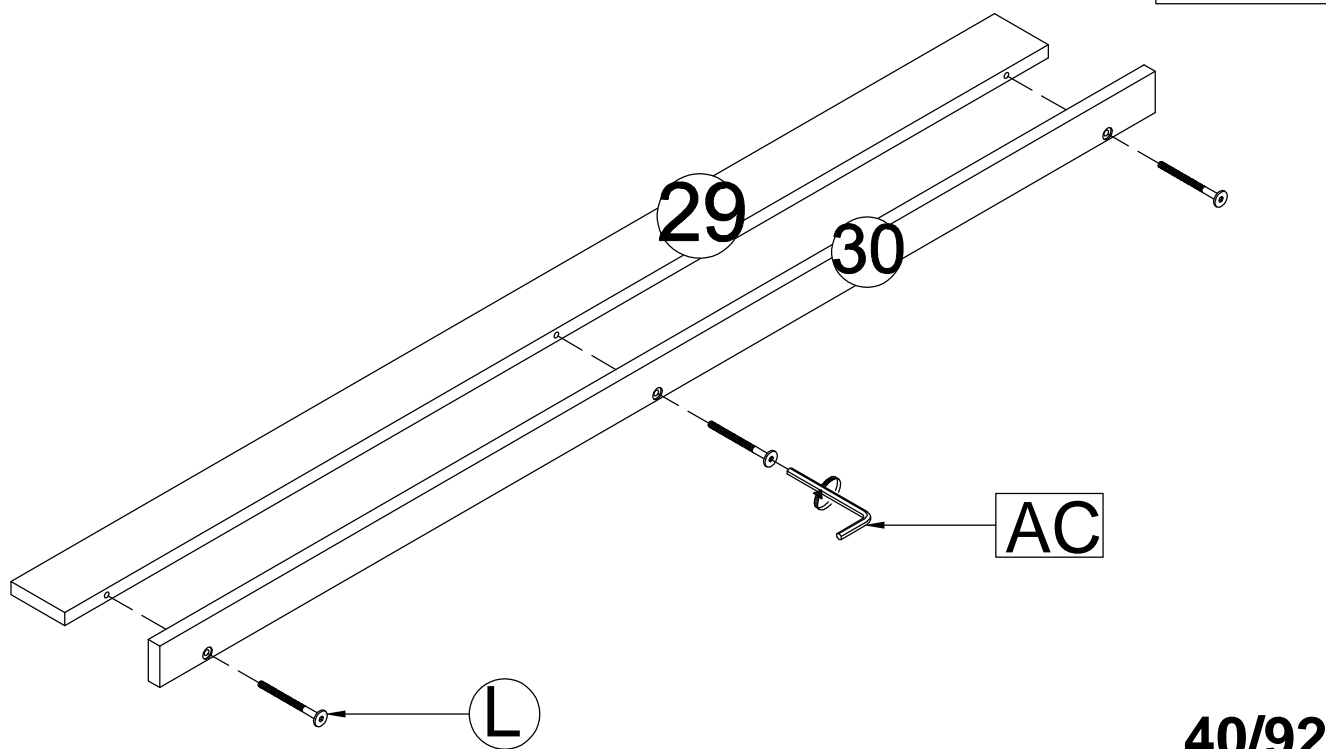
STEP 4:
ÉTAPE 4:

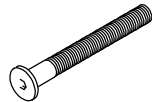

Ø6x30mm

Lx3

ACx1

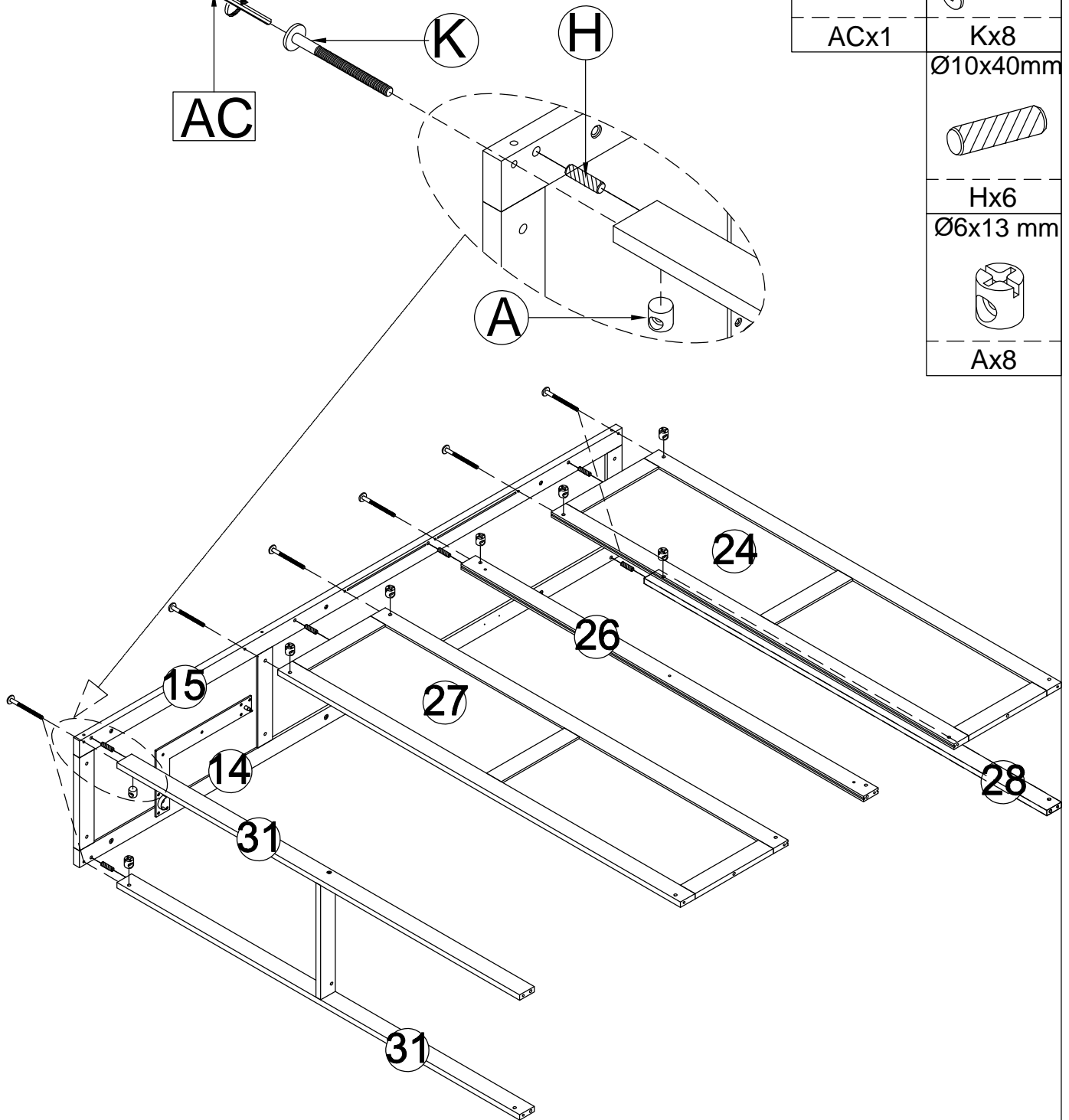
STEP 5:

ÉTAPE 5:



Four people are required to assemble and move this model
 Quatre personnes sont nécessaires pour assembler et déplacer ce modèle

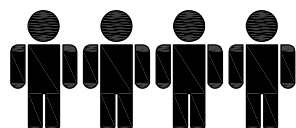
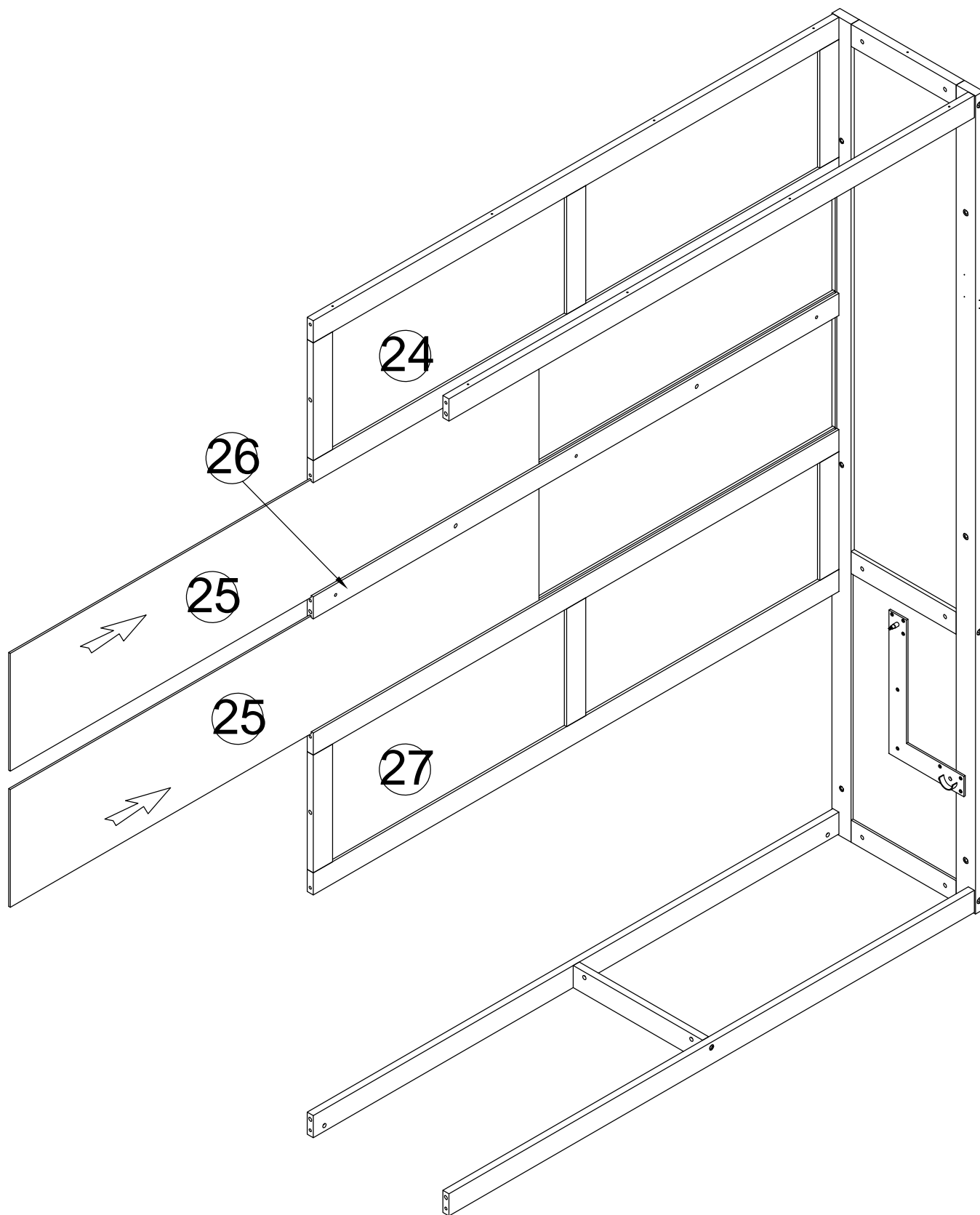

STEP 6:
ÉTAPE 6:

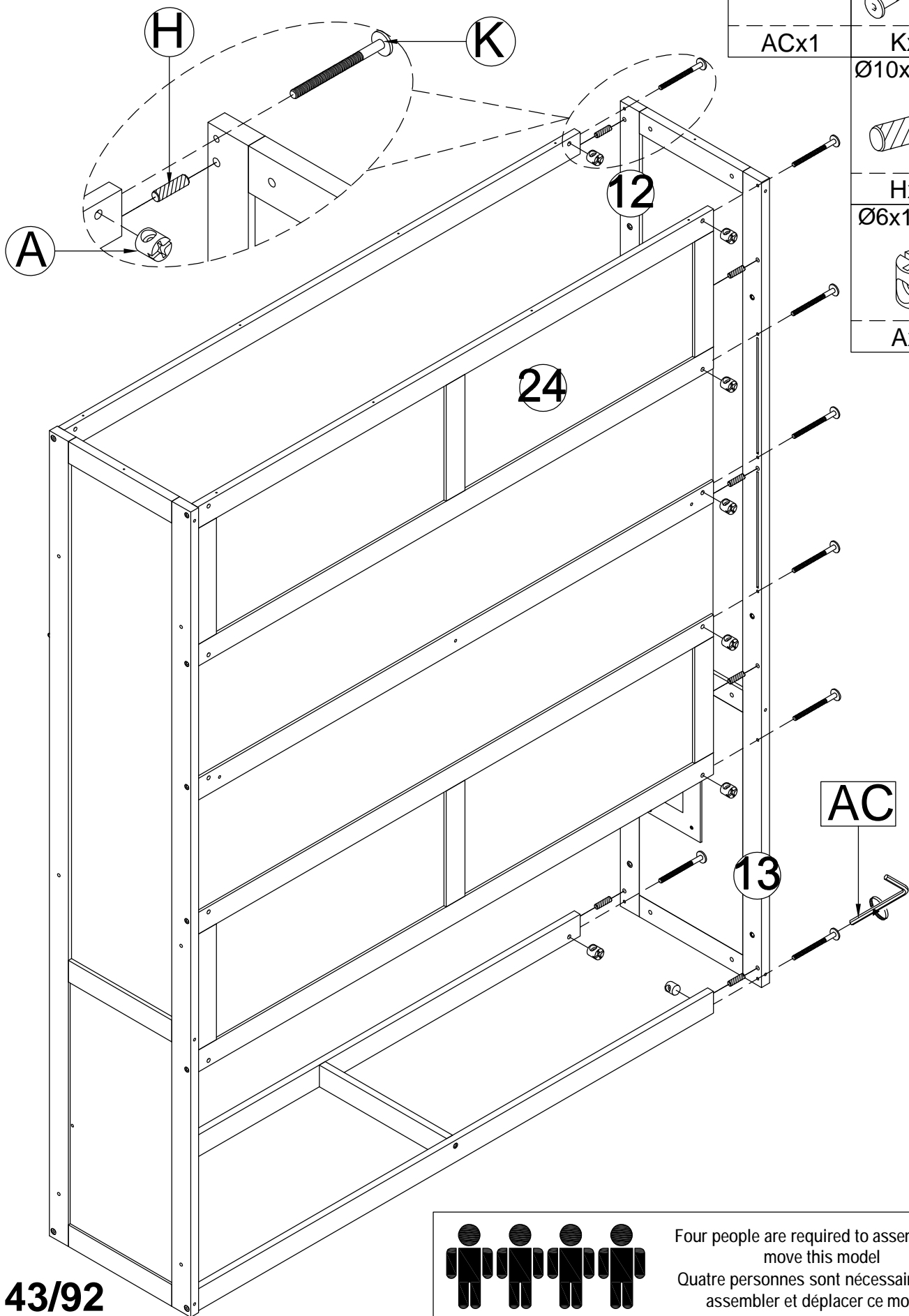

Four people are required to assemble and
move this model
Quatre personnes sont nécessaires pour
assembler et déplacer ce modèle

STEP 7:
ÉTAPE 7:

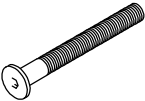
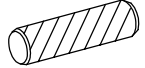
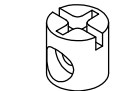

	Ø6x70mm
ACx1	Kx8
	Ø10x40mm
	Hx6
	Ø6x13 mm
	Ax8

43/92

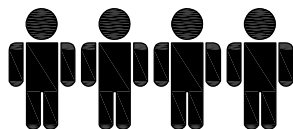

Four people are required to assemble and move this model
Quatre personnes sont nécessaires pour assembler et déplacer ce modèle

STEP 8:
ÉTAPE 8:

	$\varnothing 10 \times 40 \text{mm}$	$\varnothing 6 \times 30 \text{mm}$
ACx1	Hx2	Lx3

Back View
Vue arrière

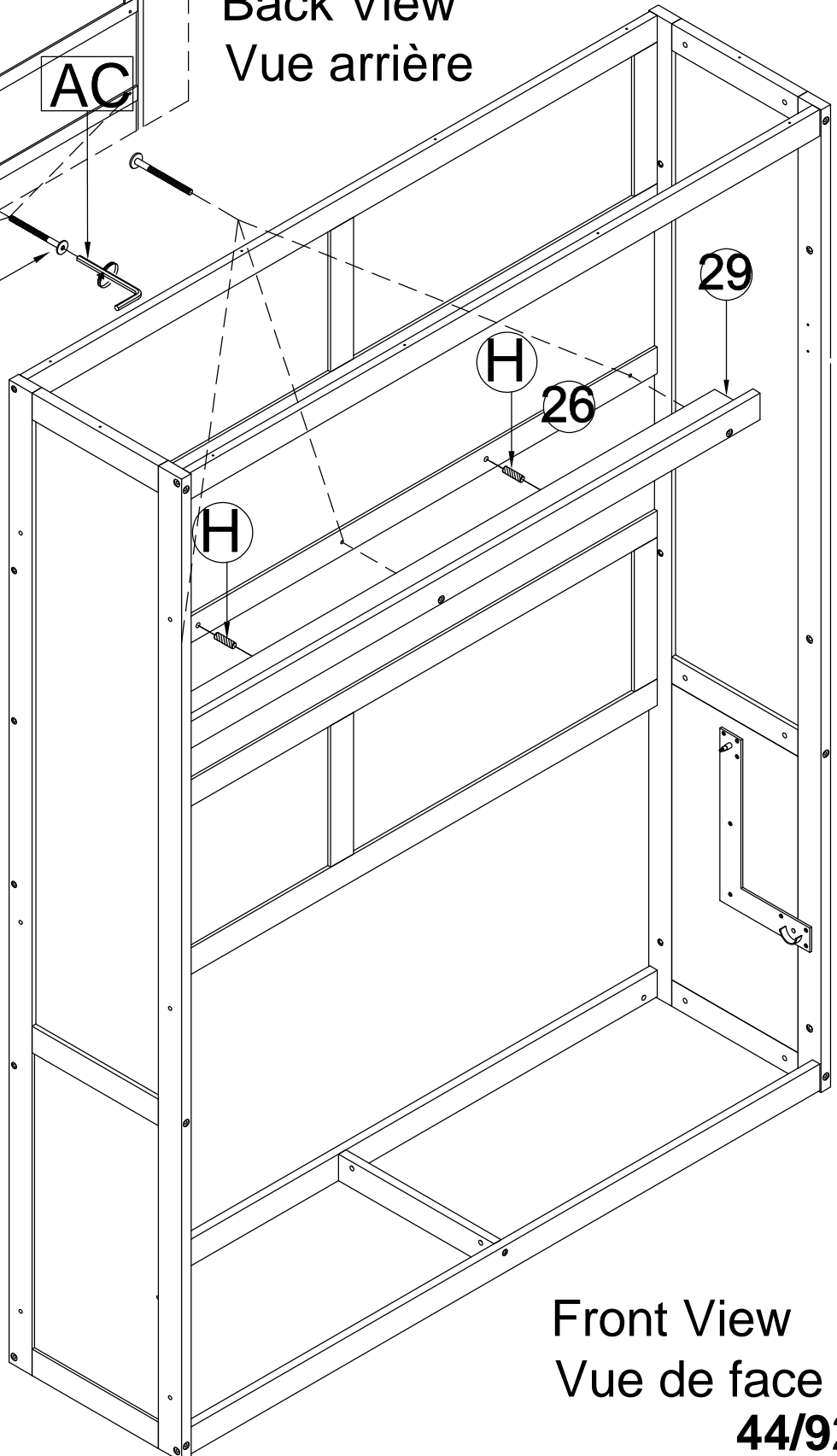
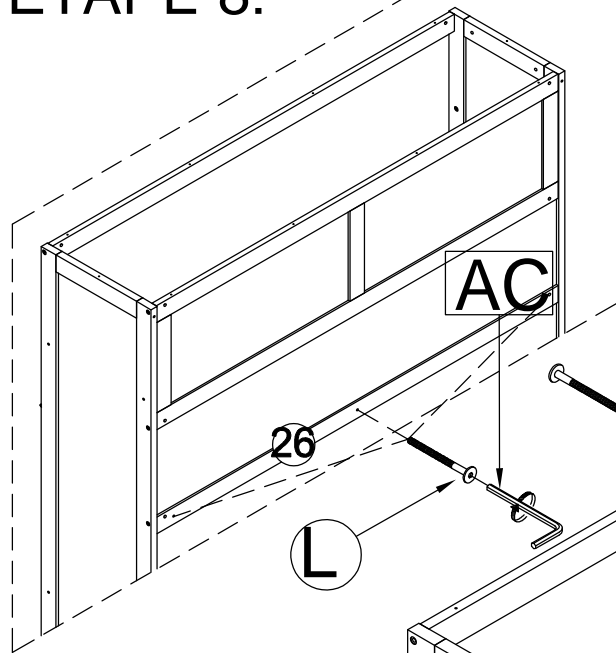

Front View
Vue de face
44/92

STEP 9:
ÉTAPE 9:

AC

M

23

	Ø6x40mm
ACx1	Mx10

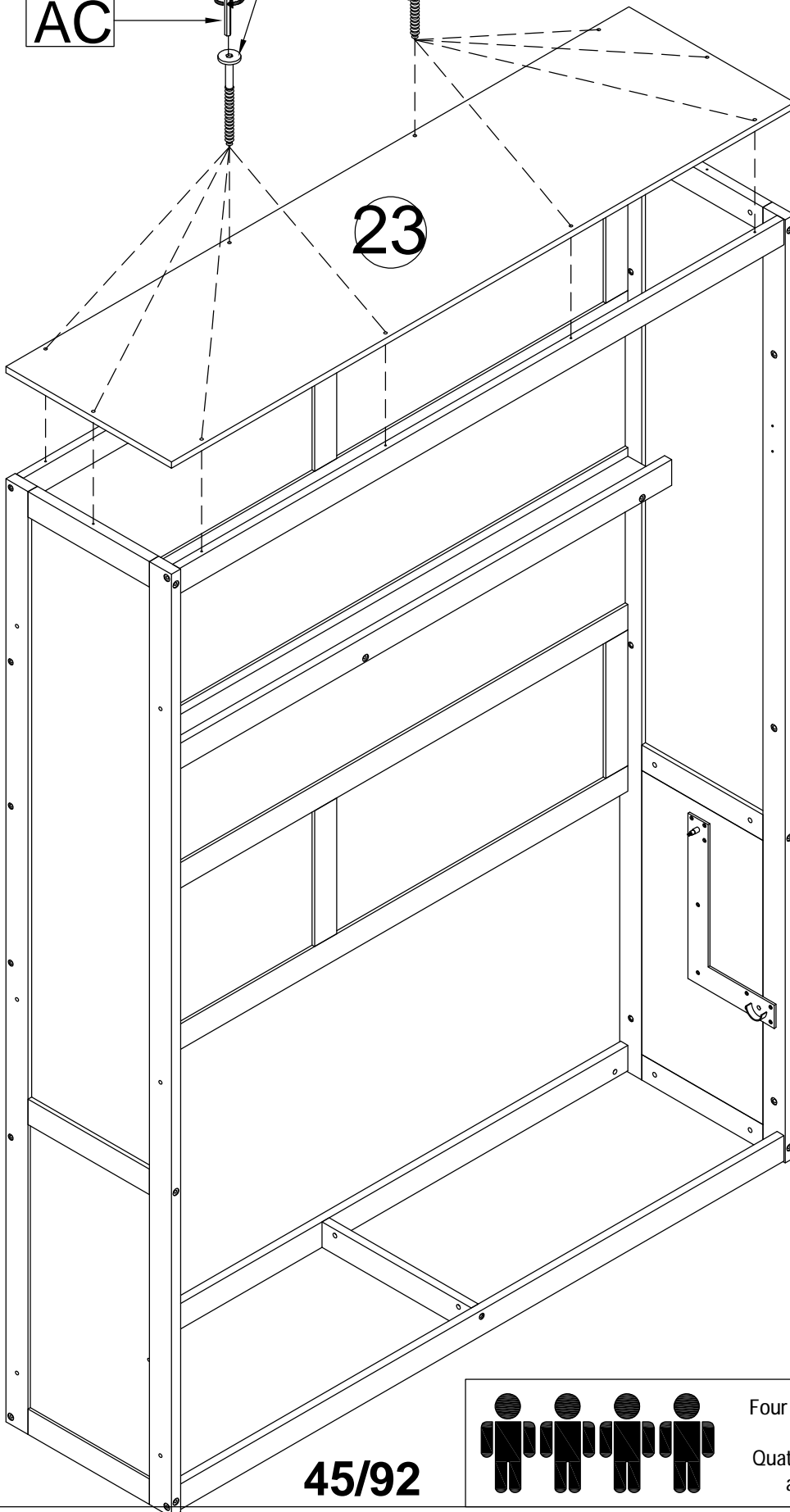

45/92

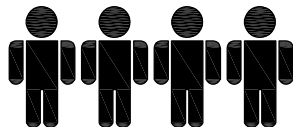

Four people are required to assemble and move this model
Quatre personnes sont nécessaires pour assembler et déplacer ce modèle

STEP 10:
ÉTAPE 10:

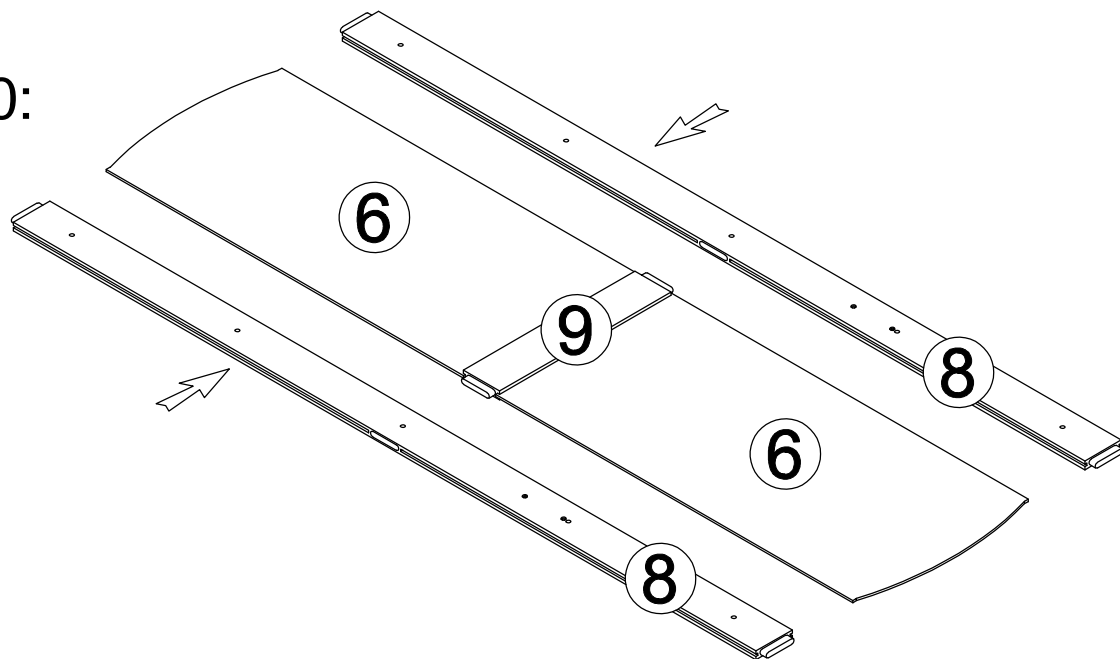

STEP 11:
ÉTAPE 11:

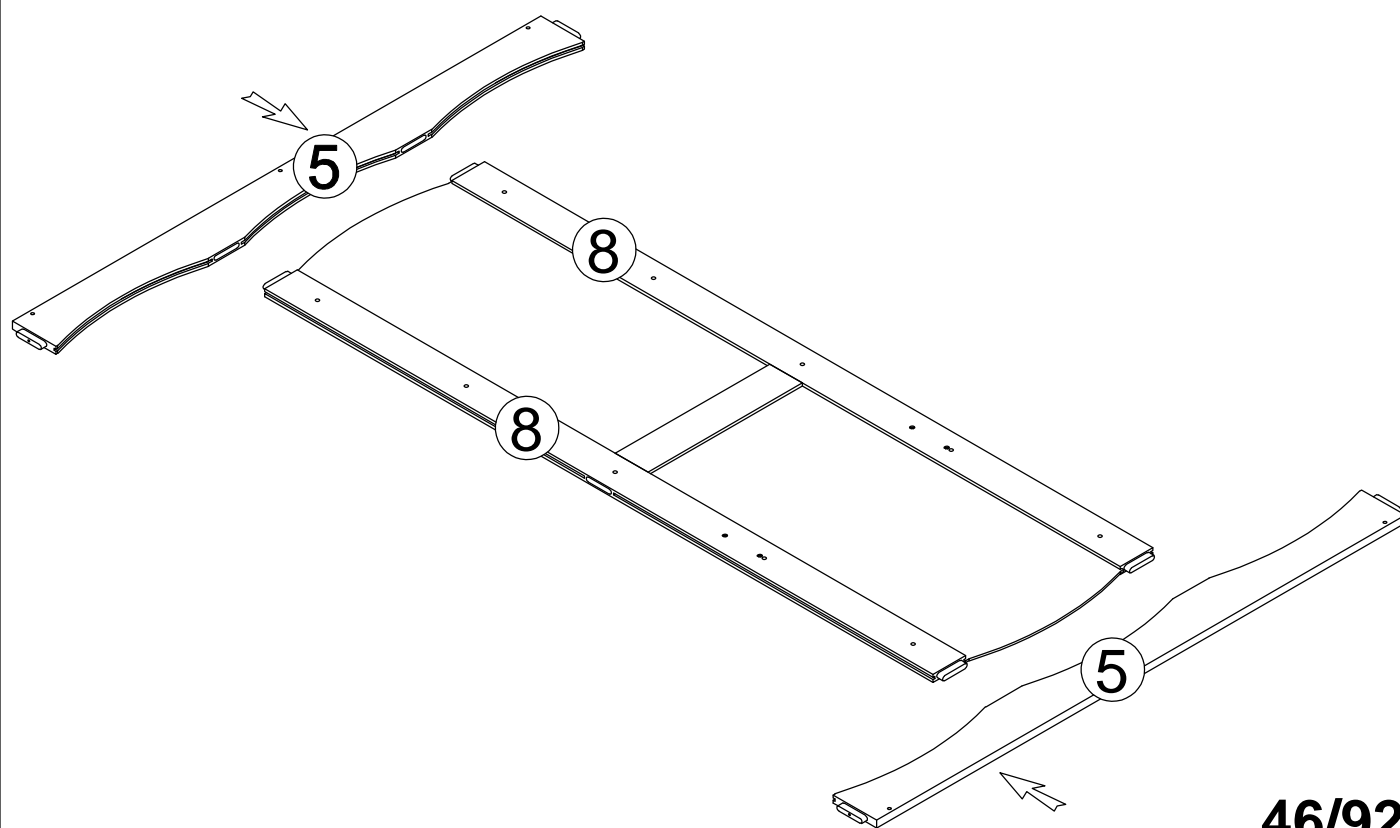

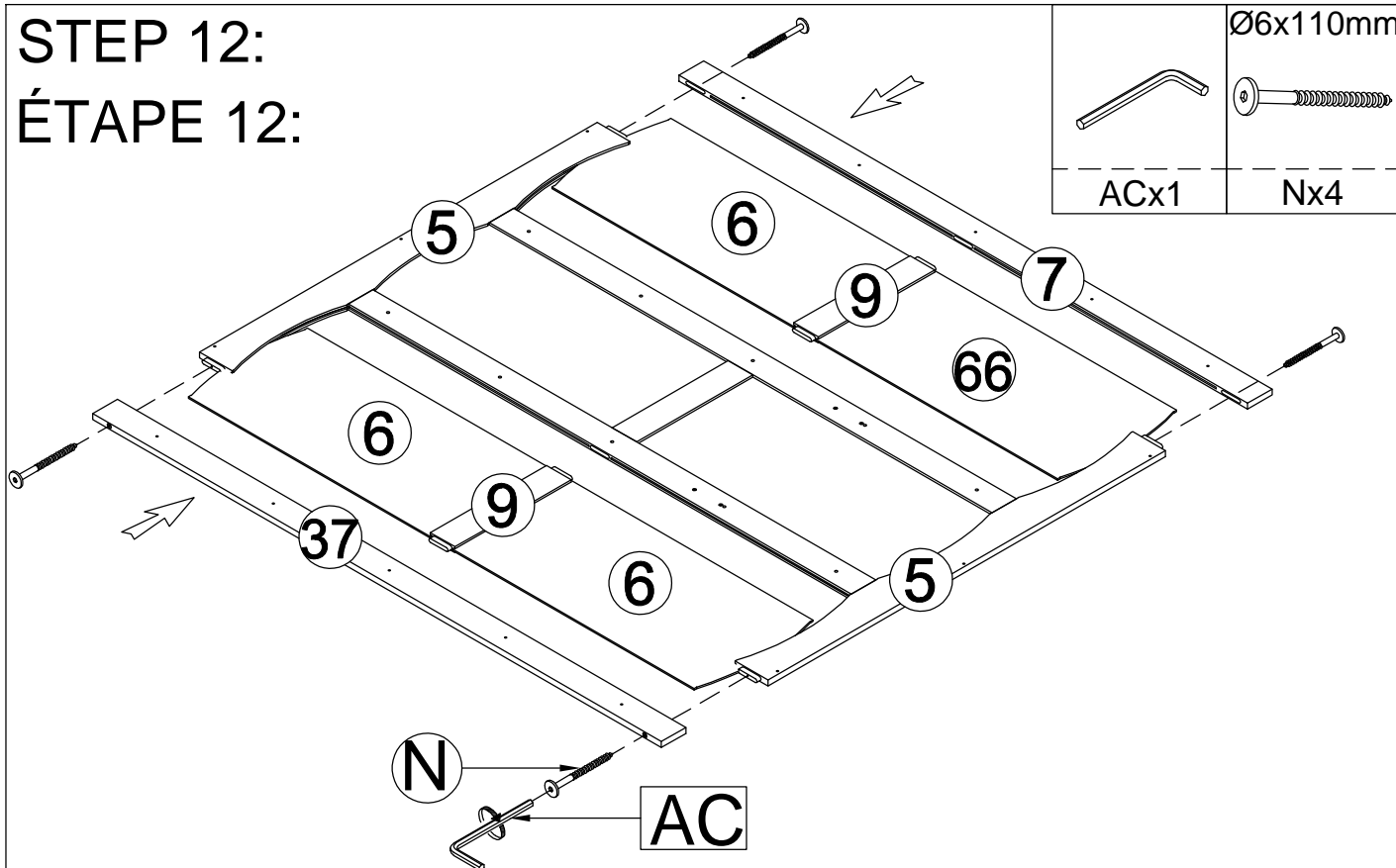

STEP 12:
ÉTAPE 12:



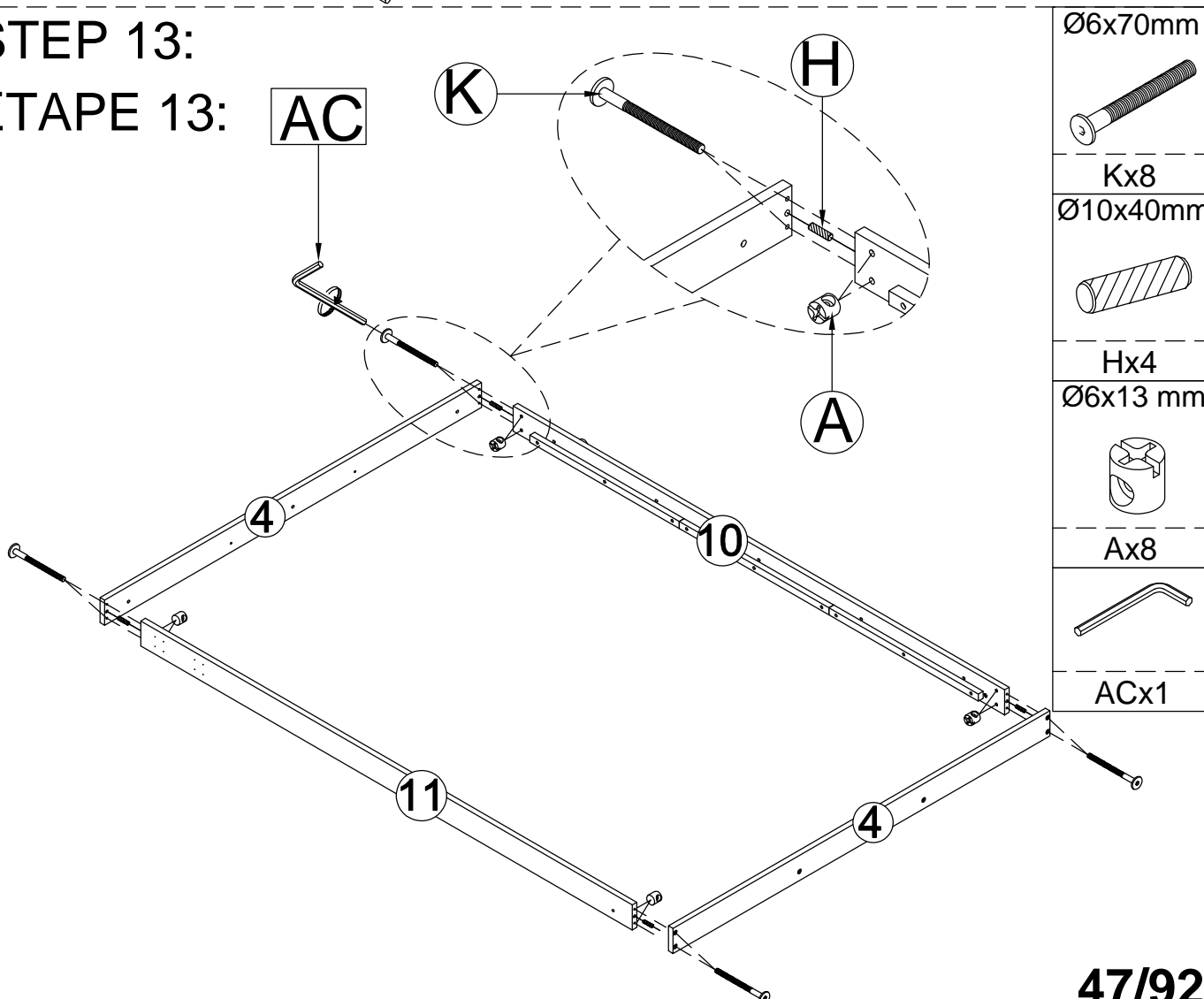

	Ø6x110mm
ACx1	Nx4

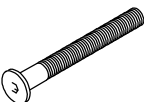
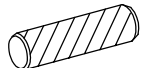
STEP 13:
ÉTAPE 13:

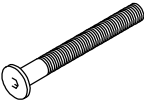

	Ø6x70mm
Kx8	
	Ø10x40mm
Hx4	
	Ø6x13 mm
Ax8	
	
ACx1	

STEP 14:
ÉTAPE 14:

	Ø6x75mm
ACx1	Px16
	Ø6x13 mm
	Ax16

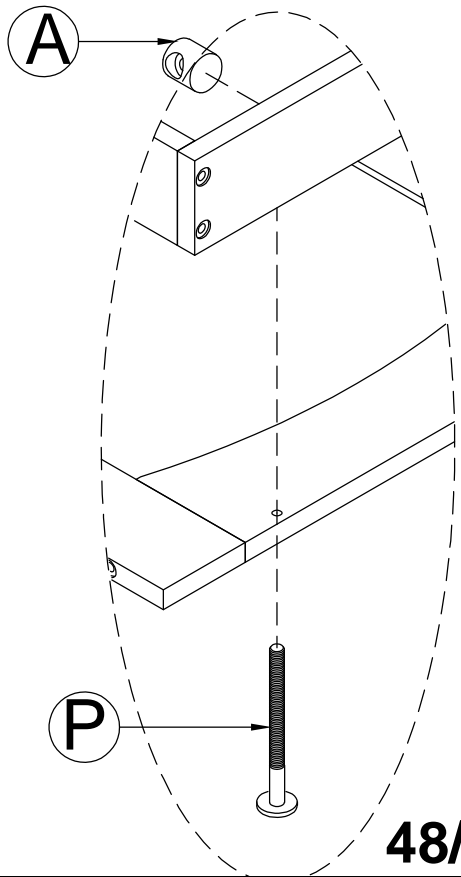
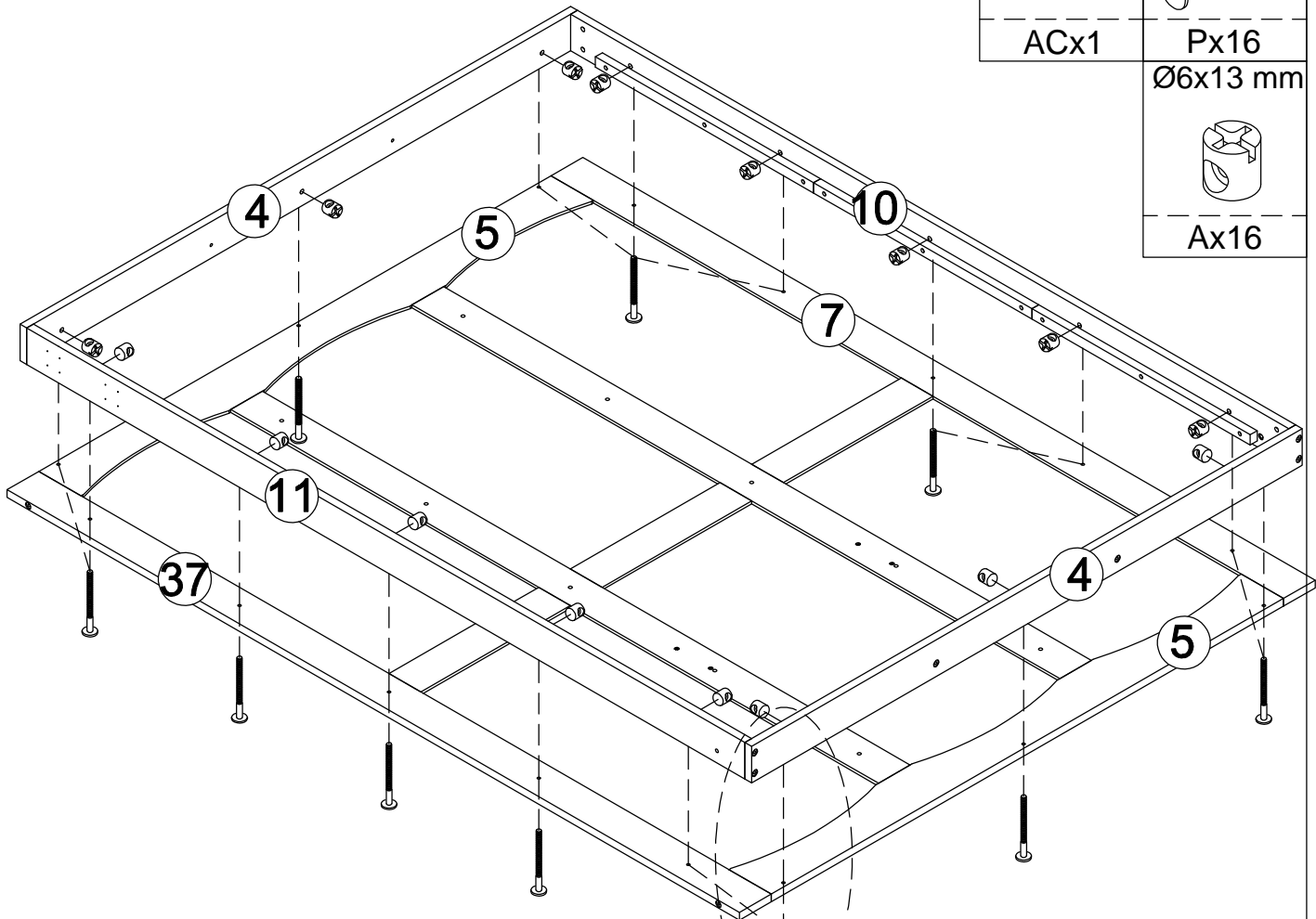

AC

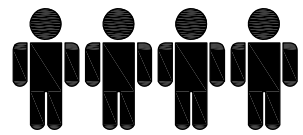

Four people are required to assemble and move this model
Quatre personnes sont nécessaires pour assembler et déplacer ce modèle

STEP 15:
ÉTAPE 15:

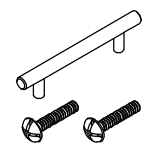

Rx2

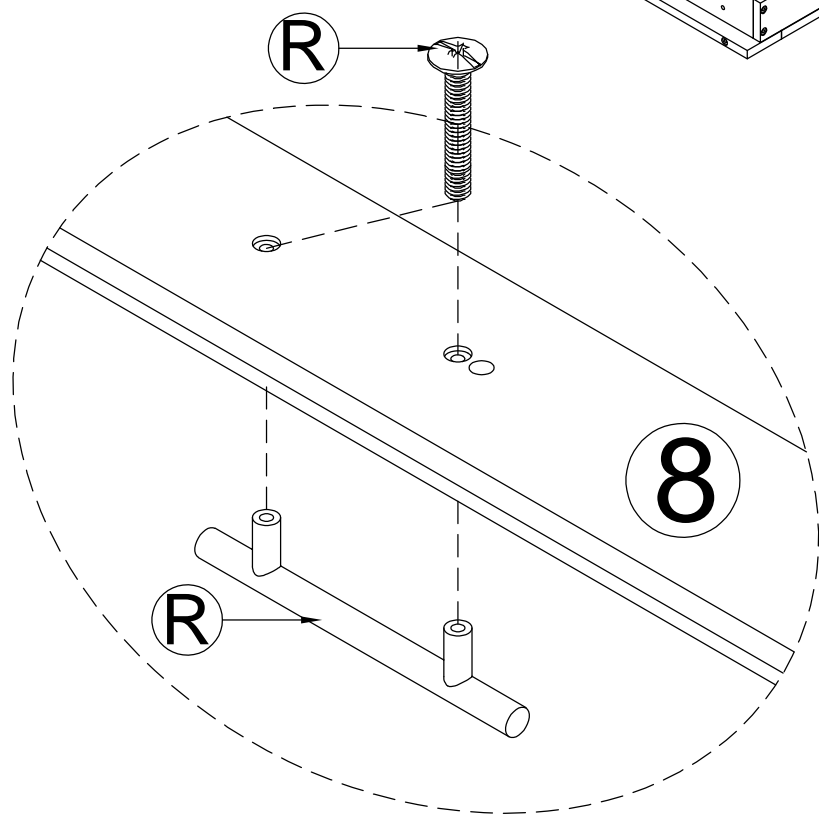
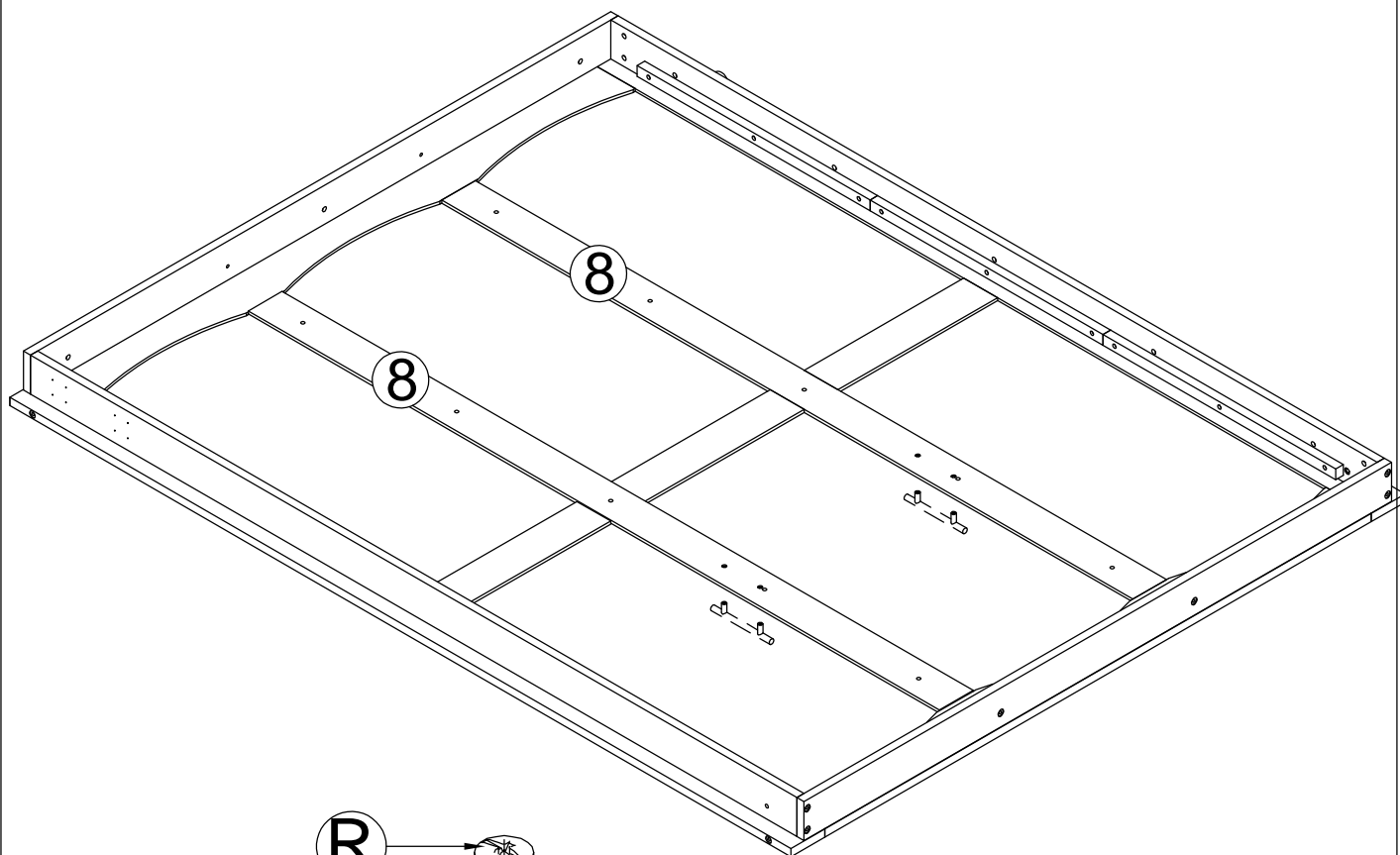

STEP 16:
ÉTAPE 16:

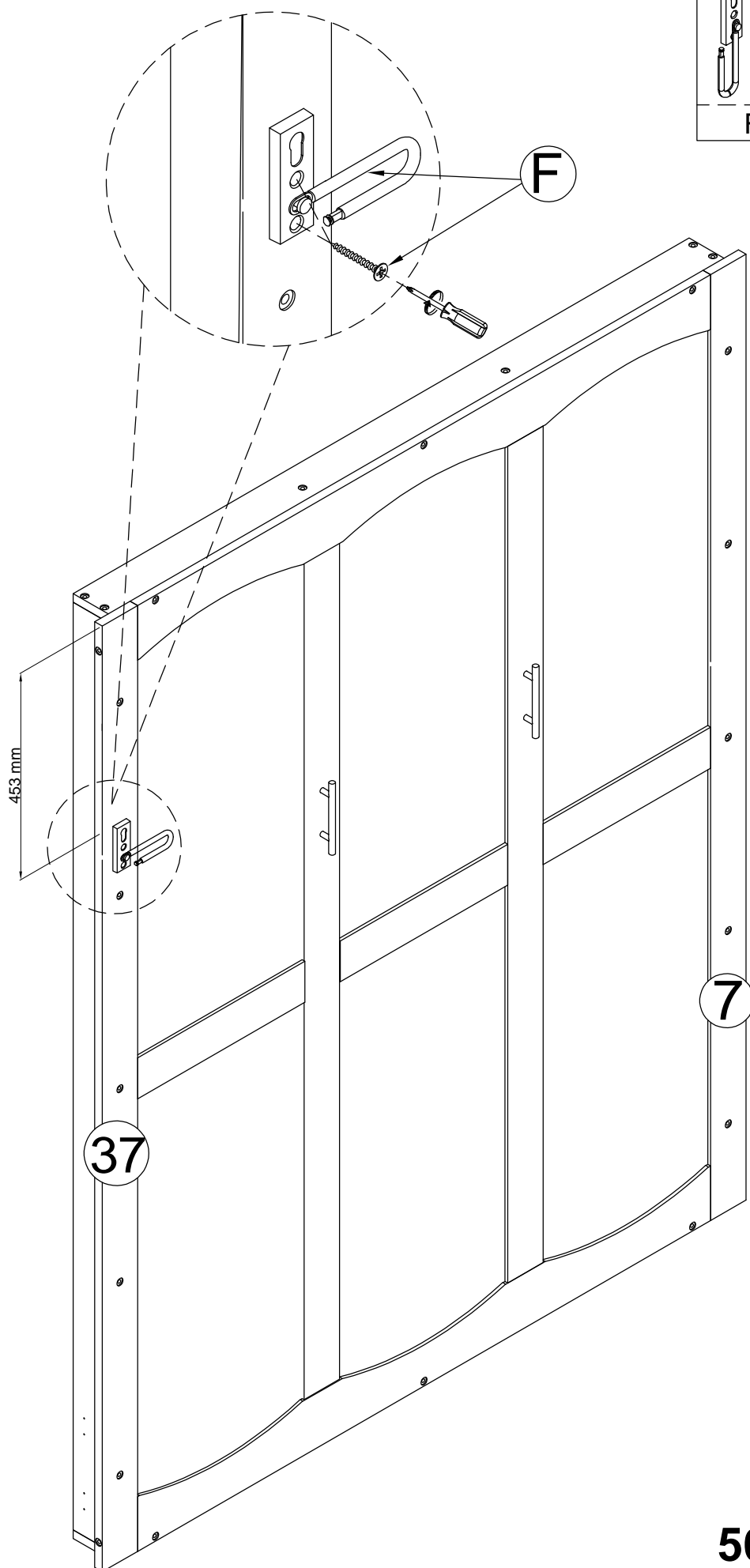
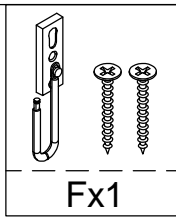

STEP 17:
ÉTAPE 17:

AC

Q

Ø6x55mm

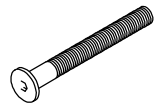

Qx10



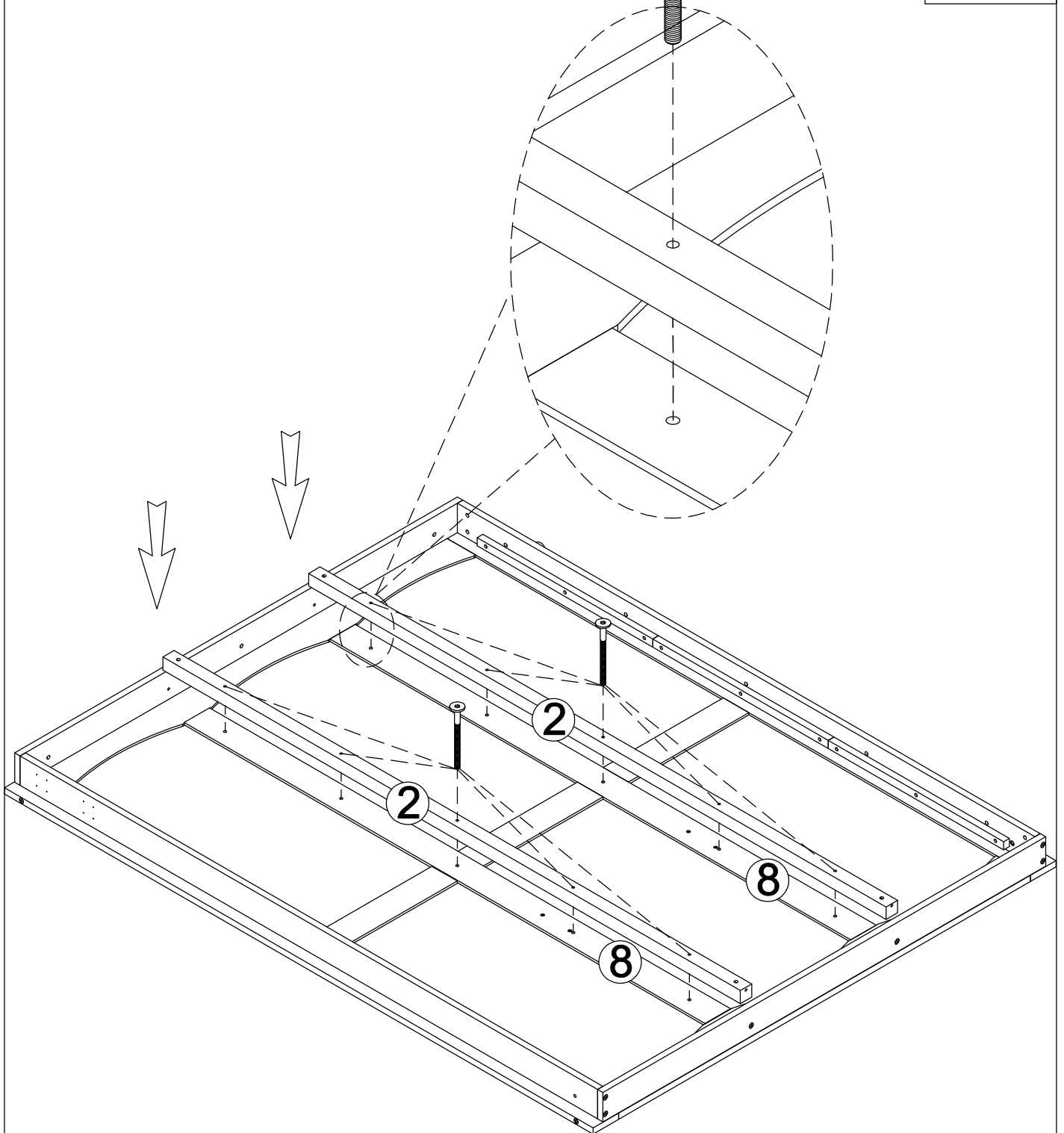

ACx1

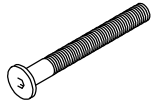

STEP 18:
ÉTAPE 18:

AC

	Ø6x70mm	Ø6x13 mm
ACx1		
	Kx4	Ax4

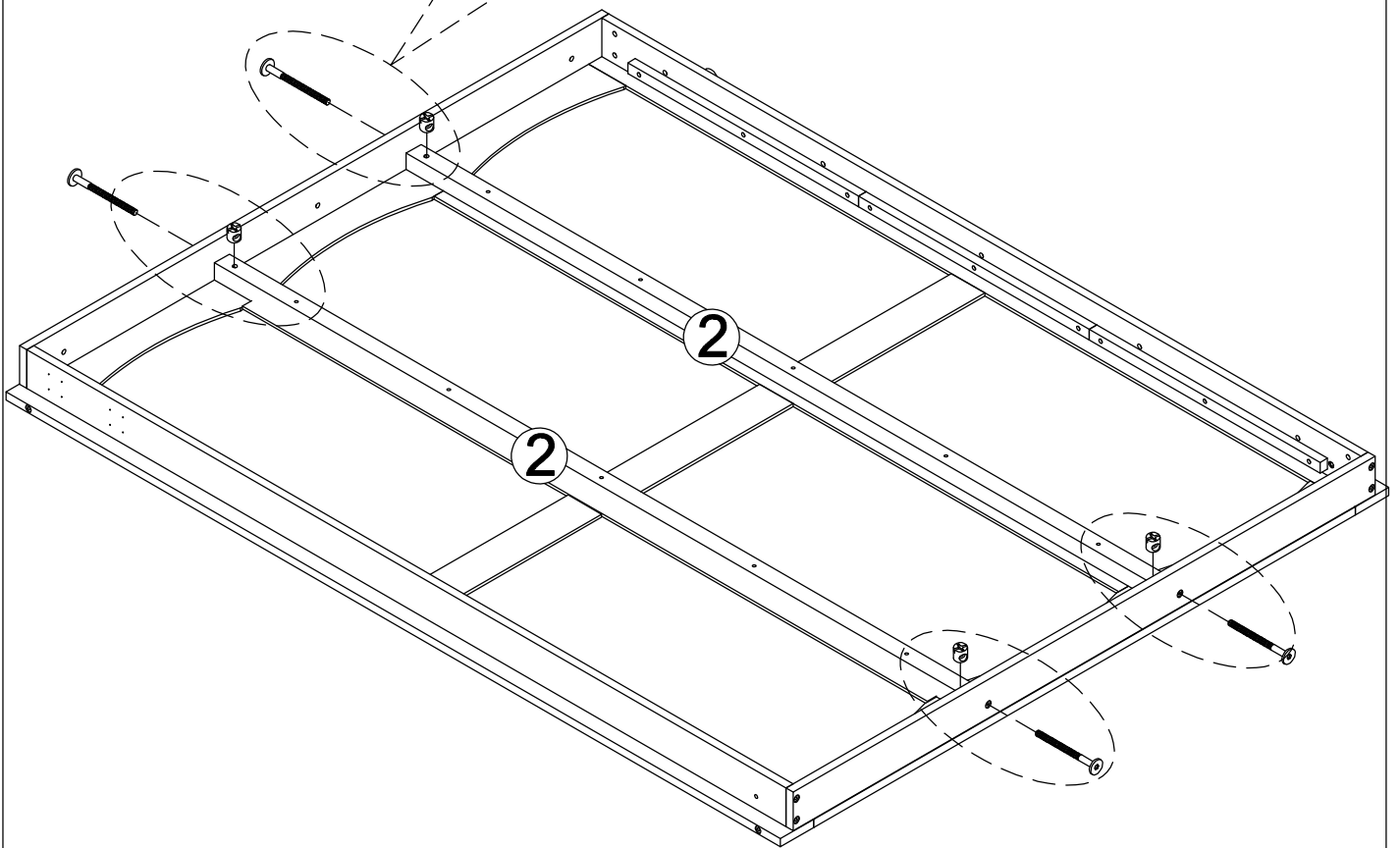
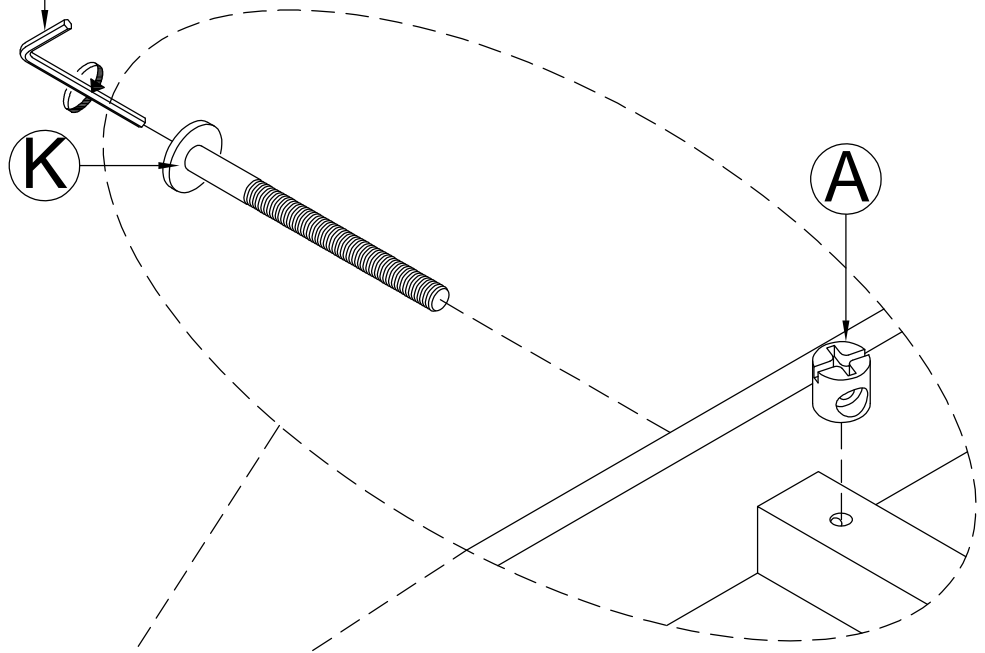

STEP 19:
ÉTAPE 19:

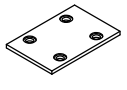
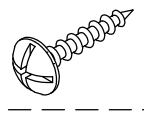
	Ø4x15mm
Tx6	
	Gx24

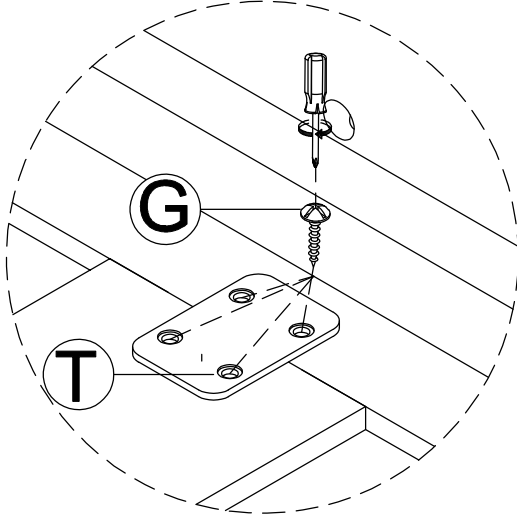
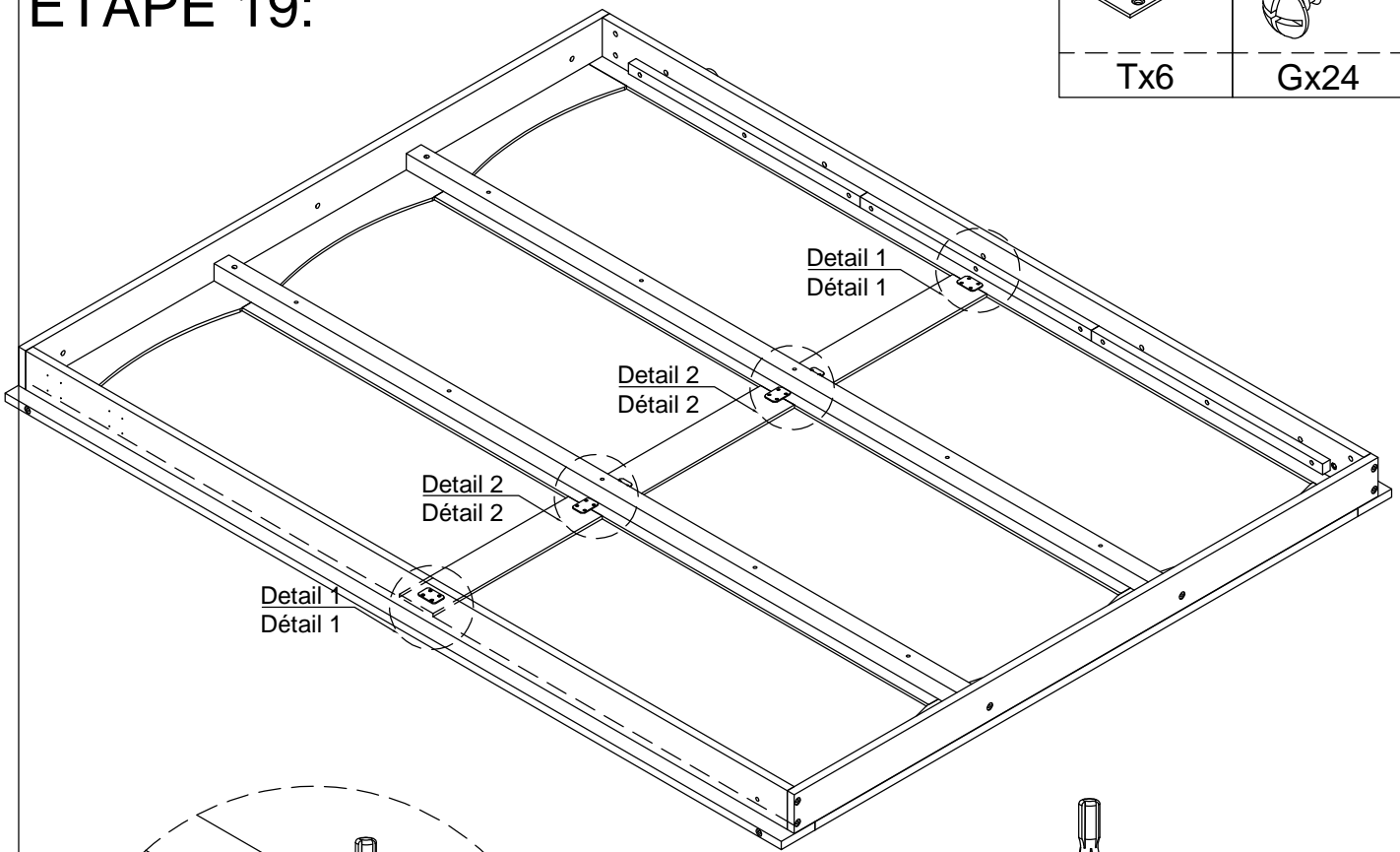

Detail 1(x2)
Détail 1(x2)

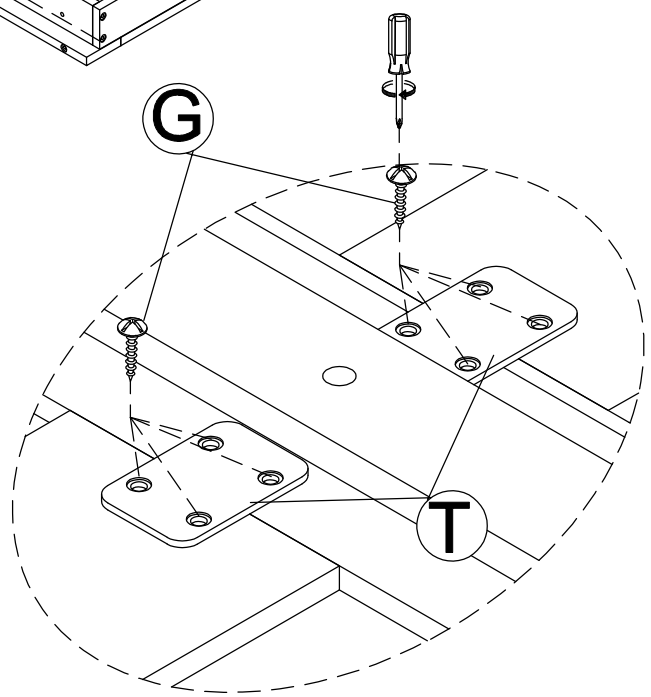

Detail 2(x2)
Détail 2(x2)

STEP 20:
ÉTAPE 20:

Ø4x30mm

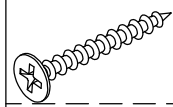

Dx24

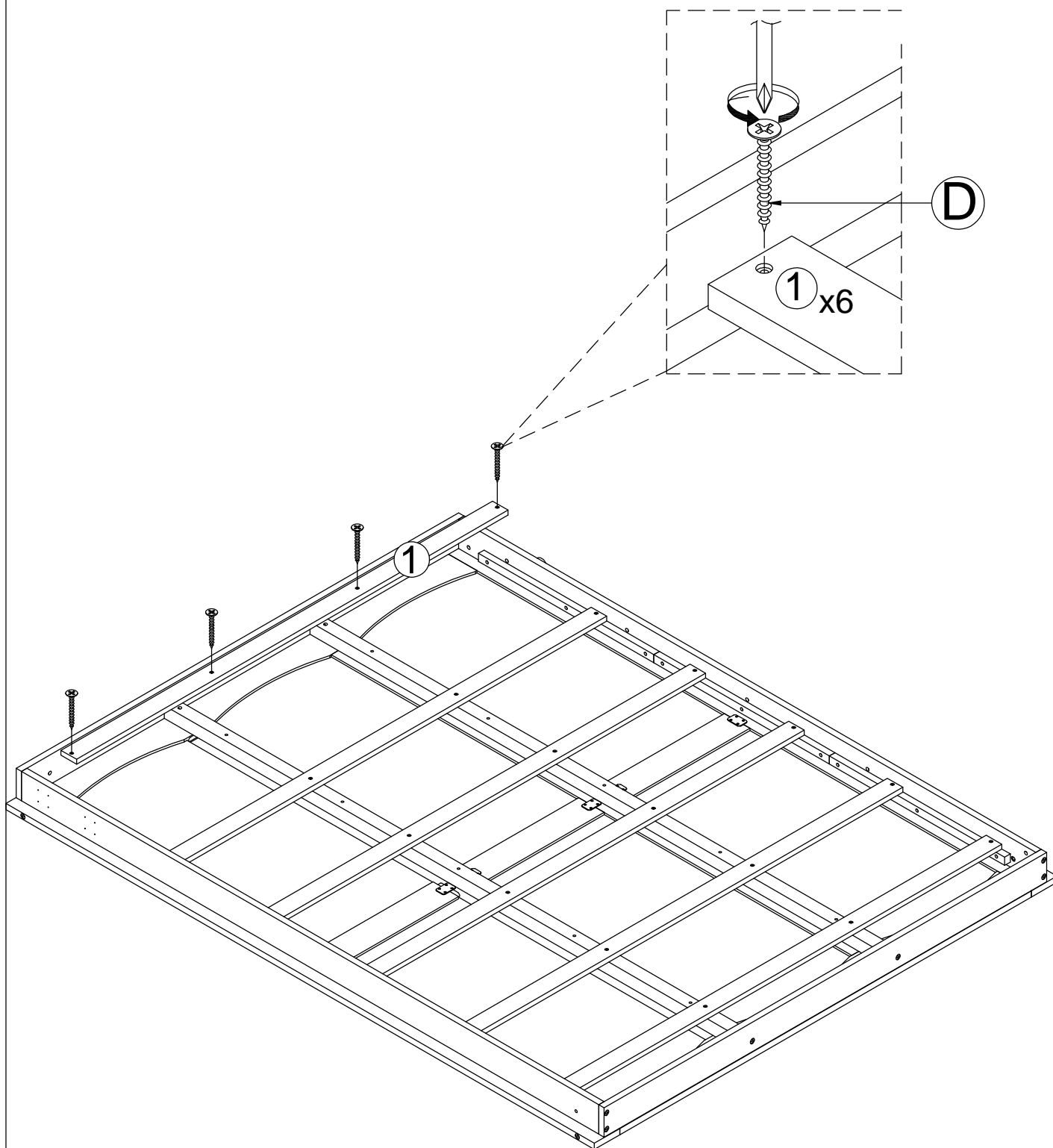

STEP 21:
ÉTAPE 21:

Ø4x20mm

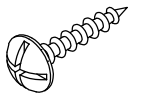

Cx8

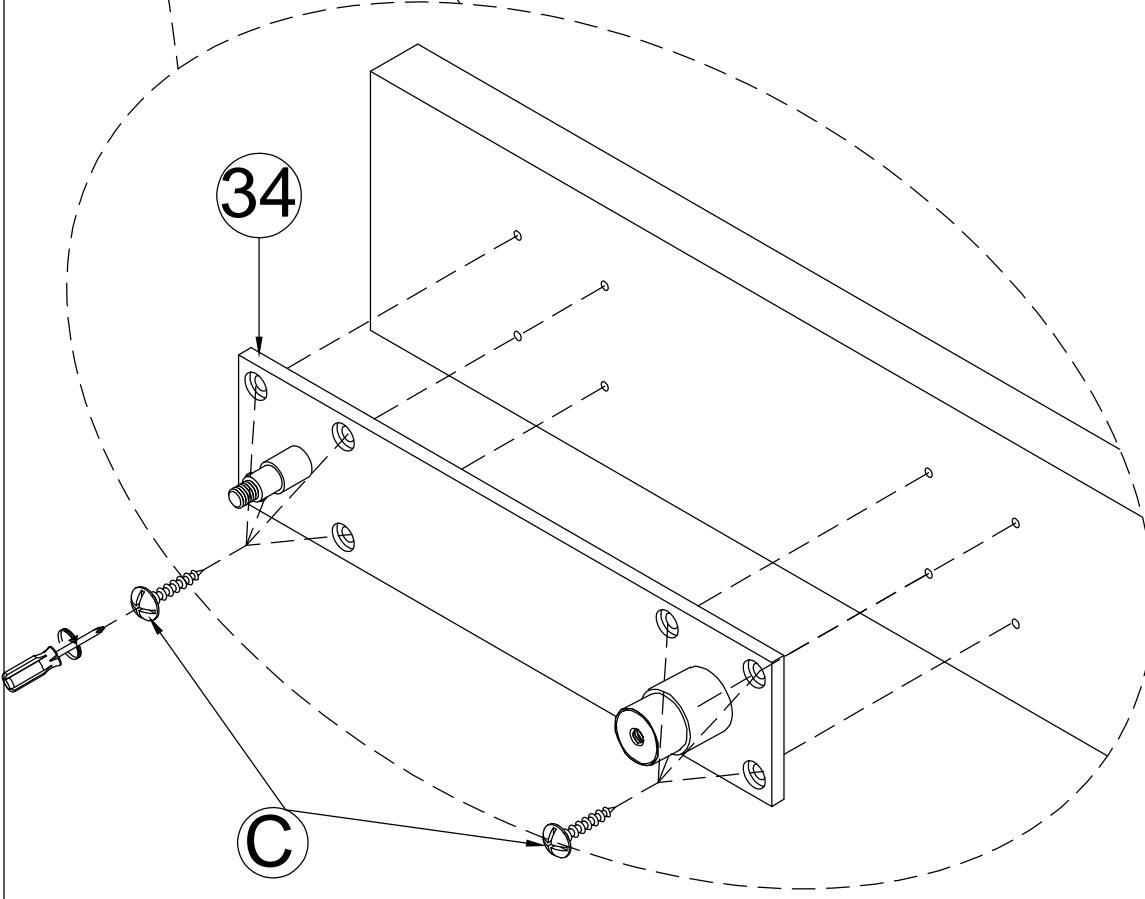
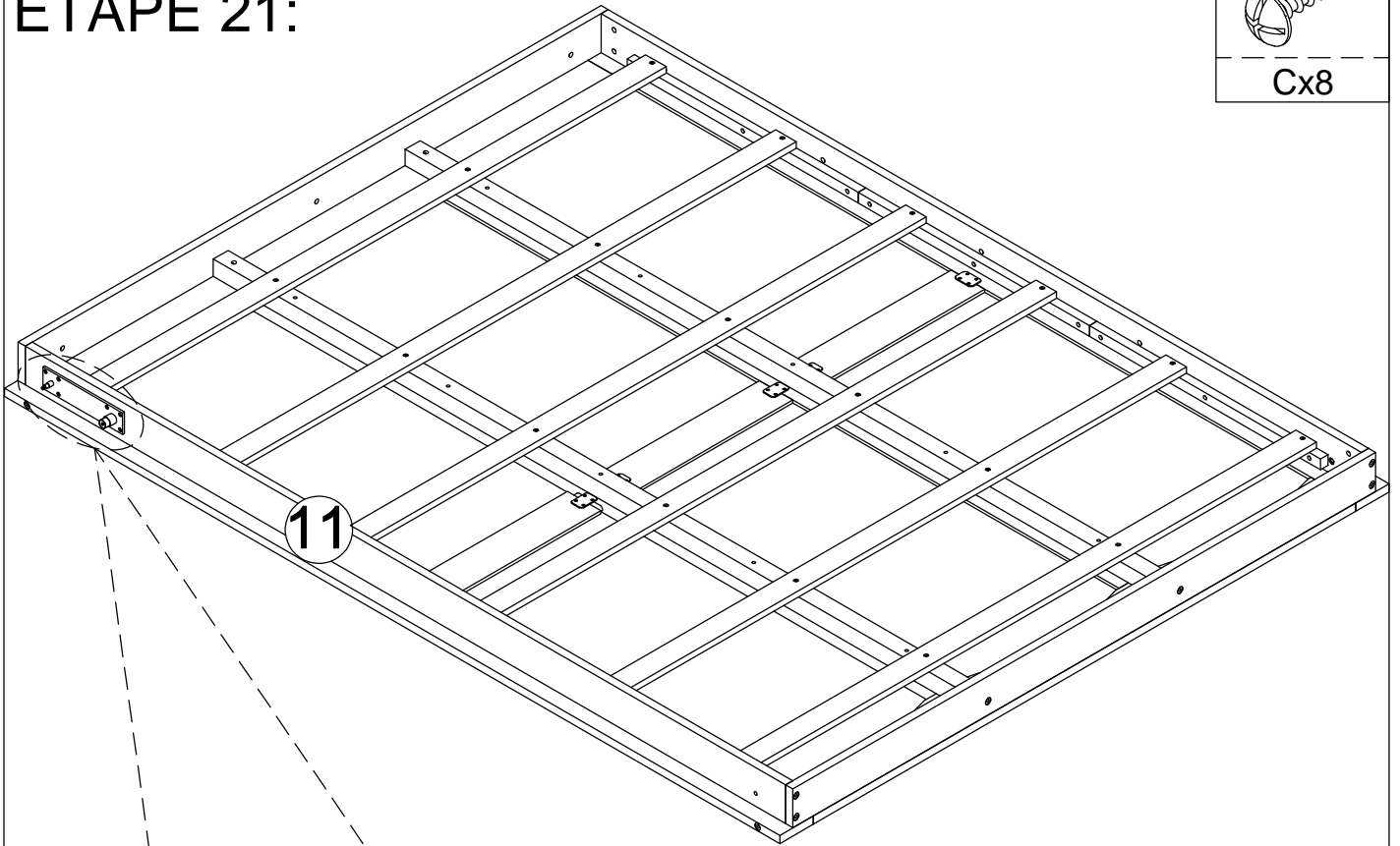

STEP 22:
ÉTAPE 22:

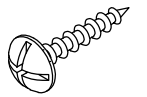

Ø4x20mm

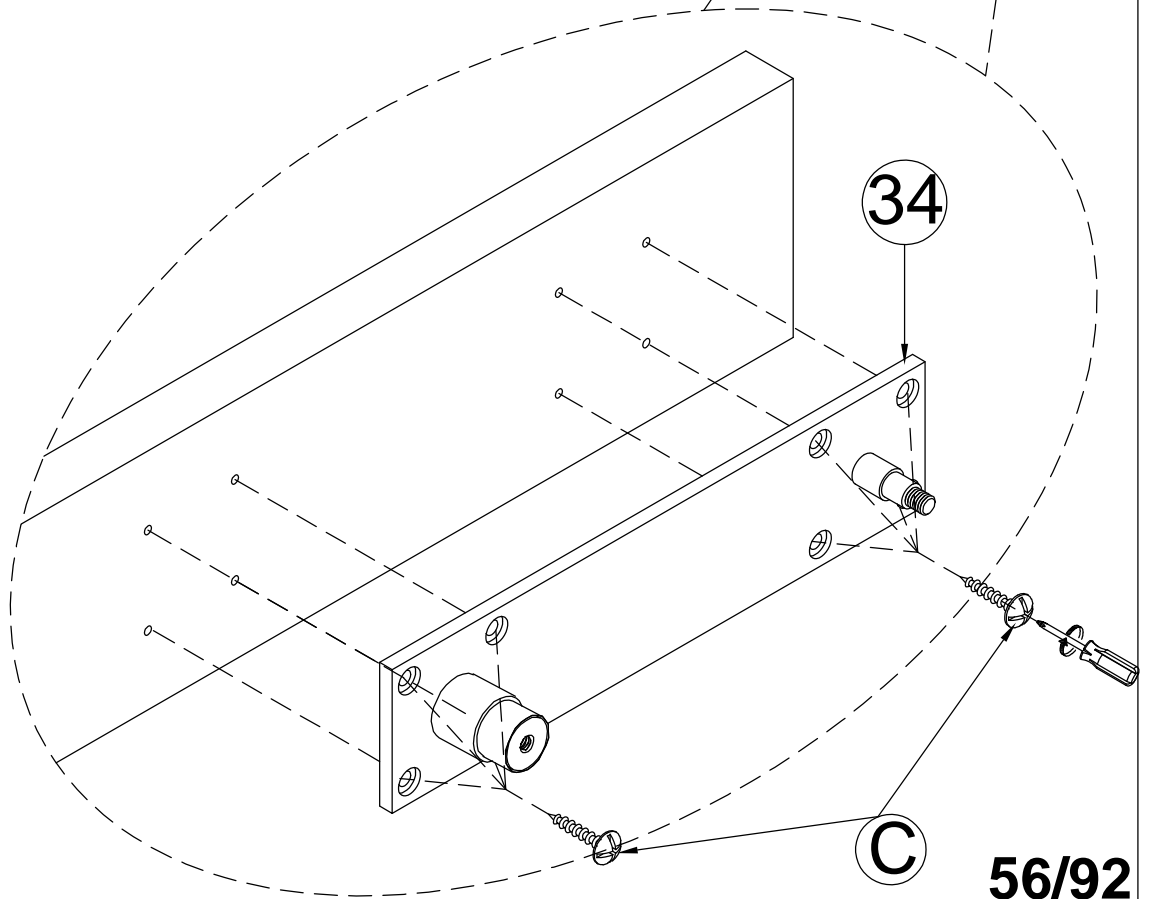
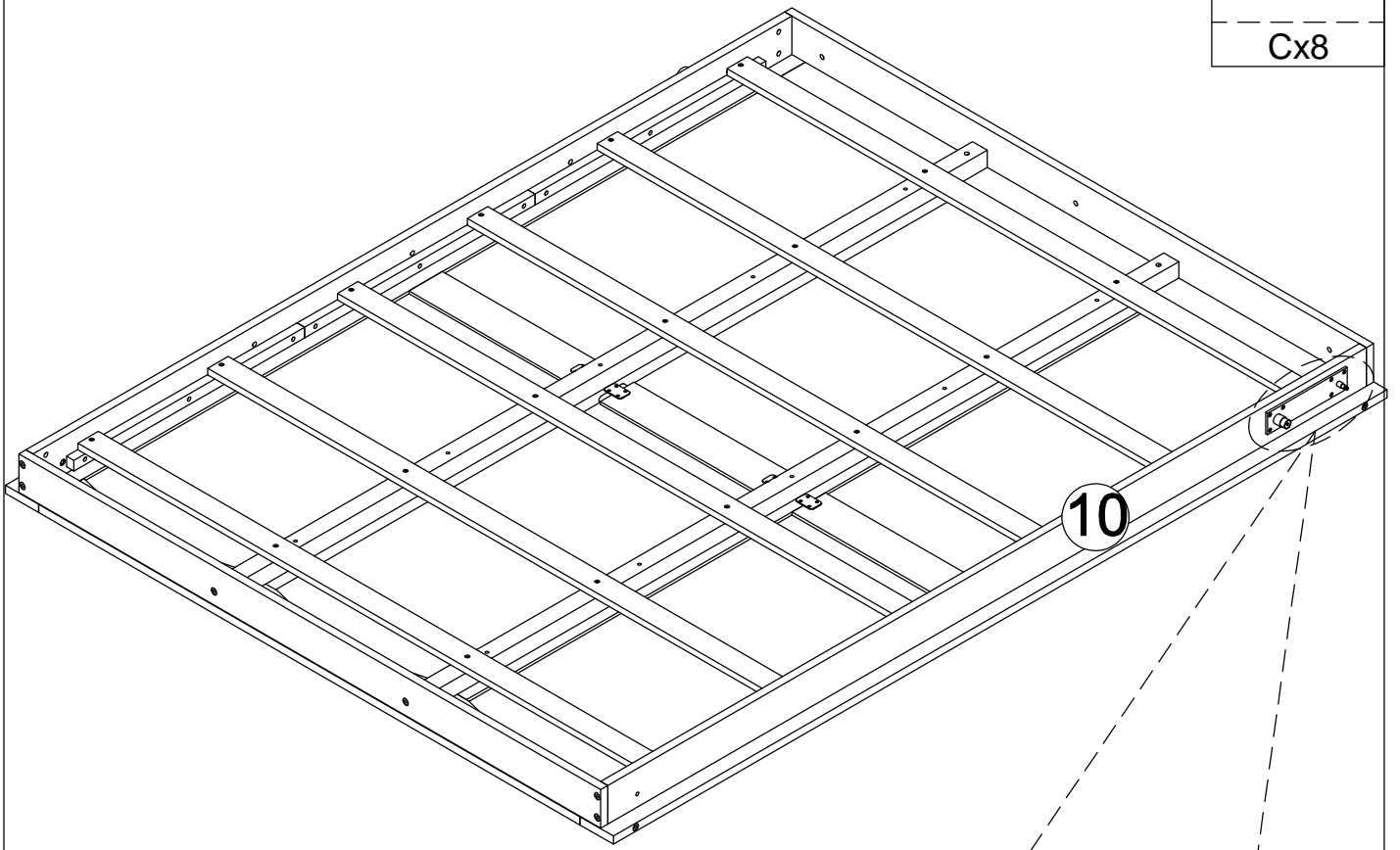

Cx8

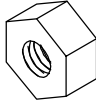

STEP 23:
ÉTAPE 23:

		
33x2	Ux2	Vx2

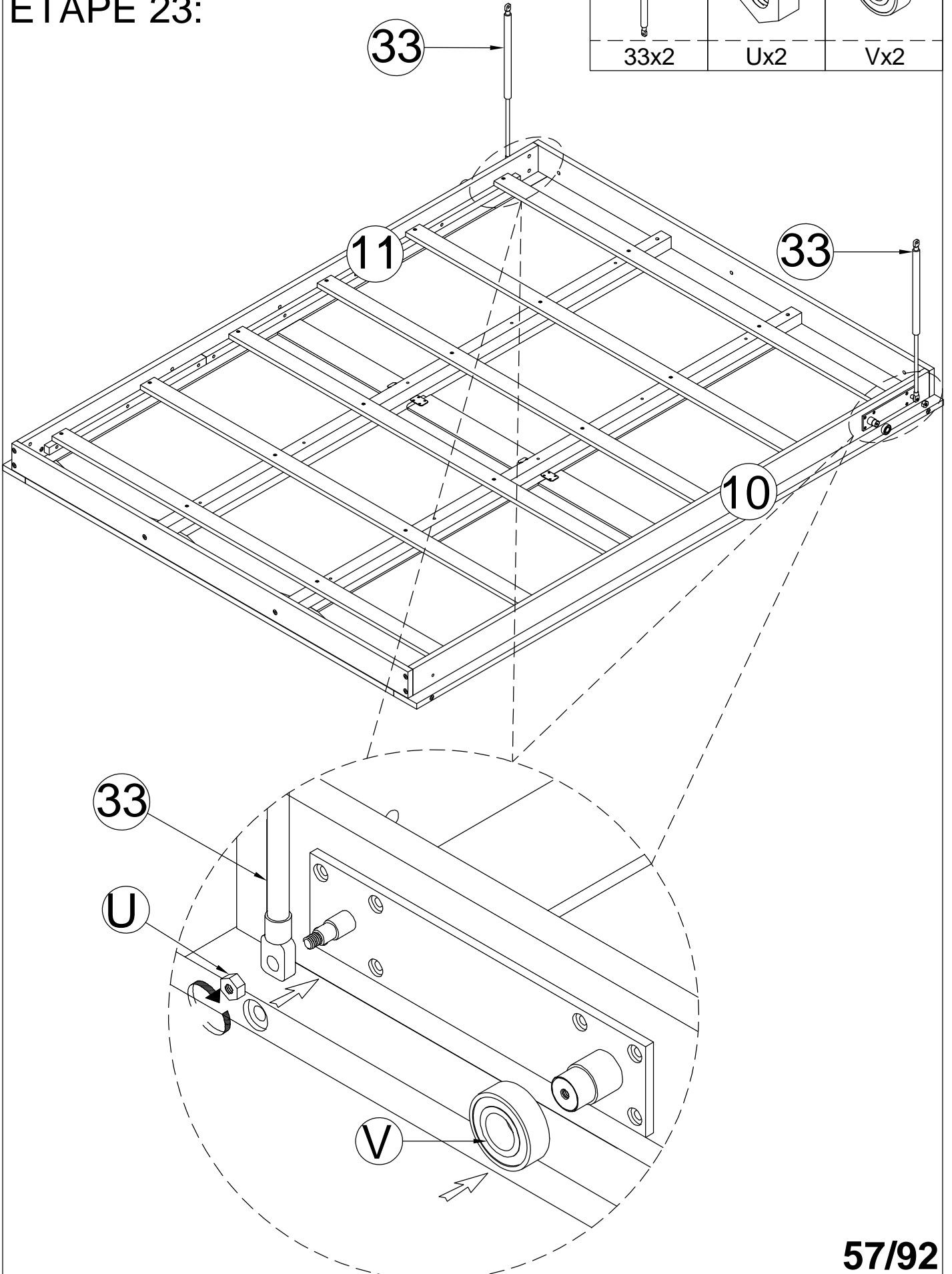

STEP 24:
ÉTAPE 24:

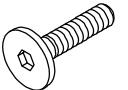
	Ø8x40mm
ACx1	
	Xx2

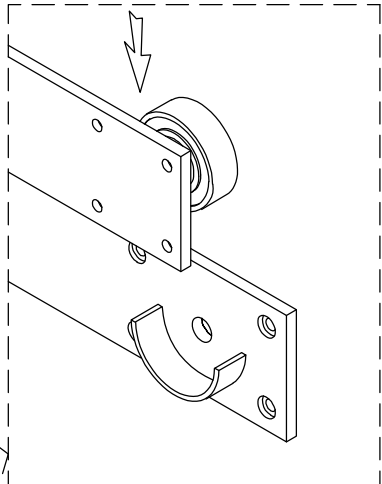
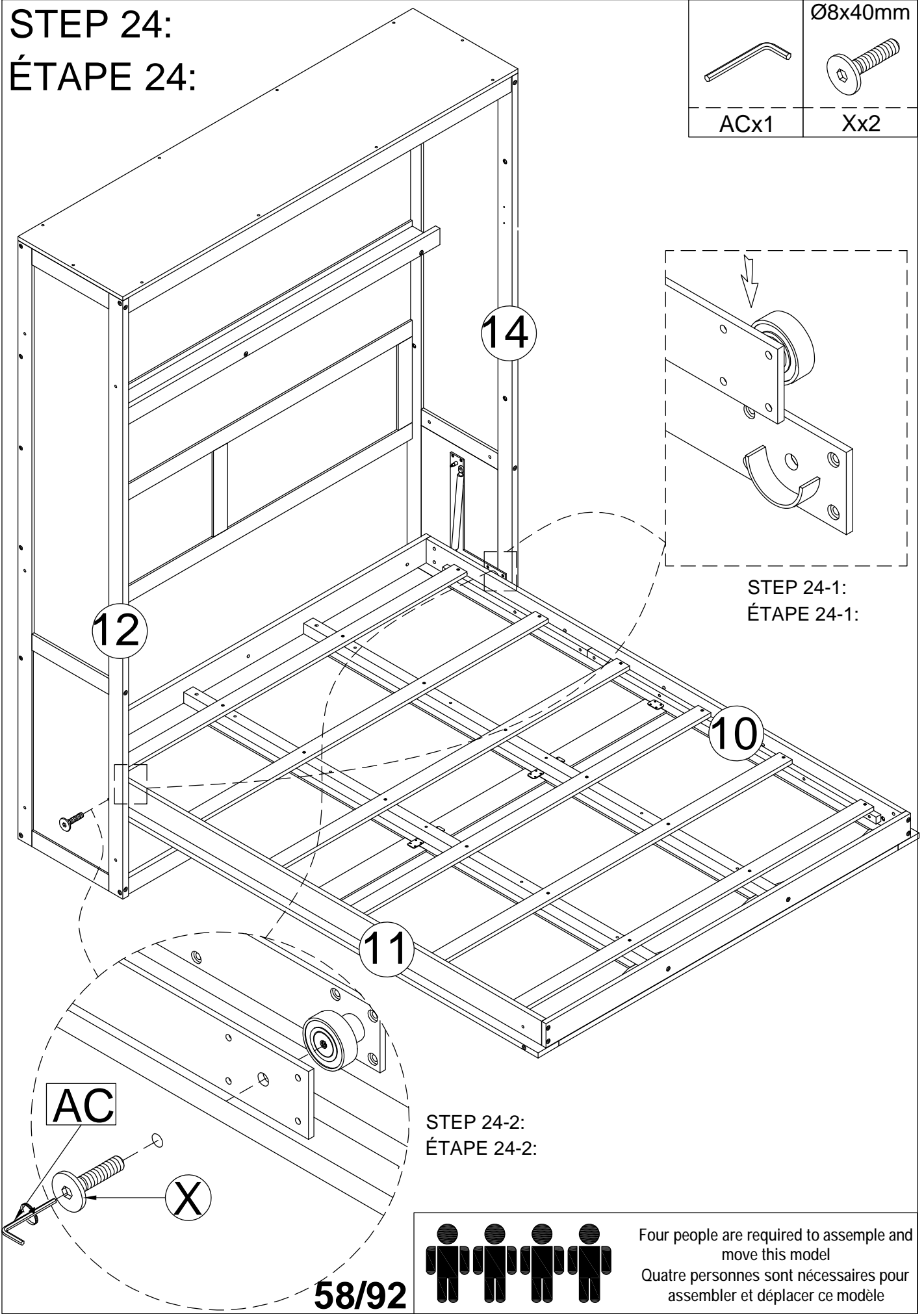

STEP 24-1:
ÉTAPE 24-1:

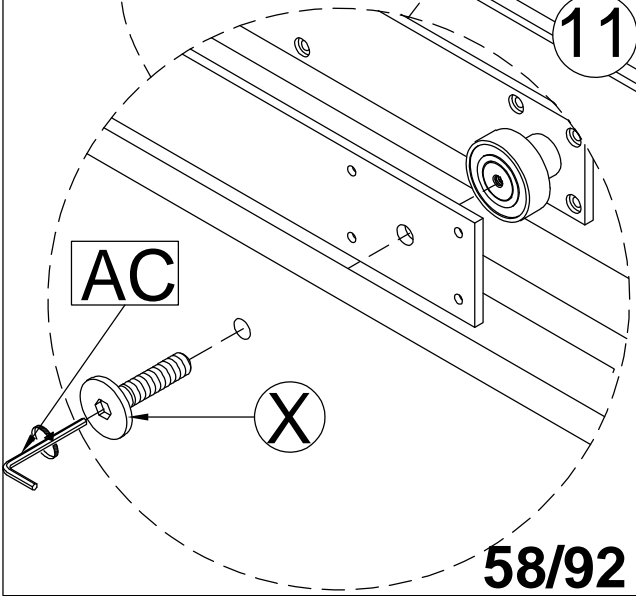

STEP 24-2:
ÉTAPE 24-2:

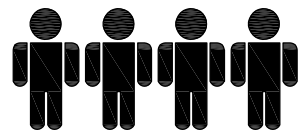

Four people are required to assemble and move this model
Quatre personnes sont nécessaires pour assembler et déplacer ce modèle

STEP 25-1:
ÉTAPE 25-1:

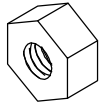

Ux1

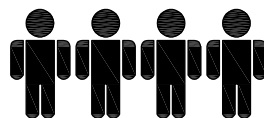
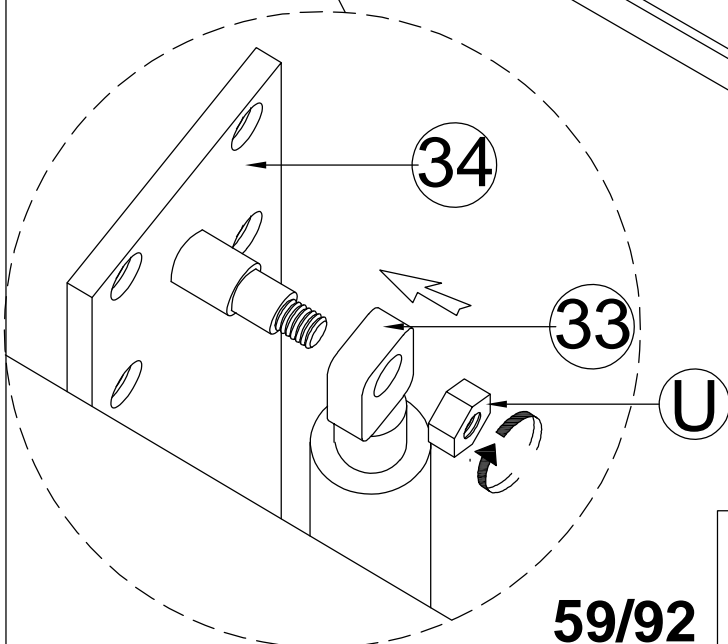
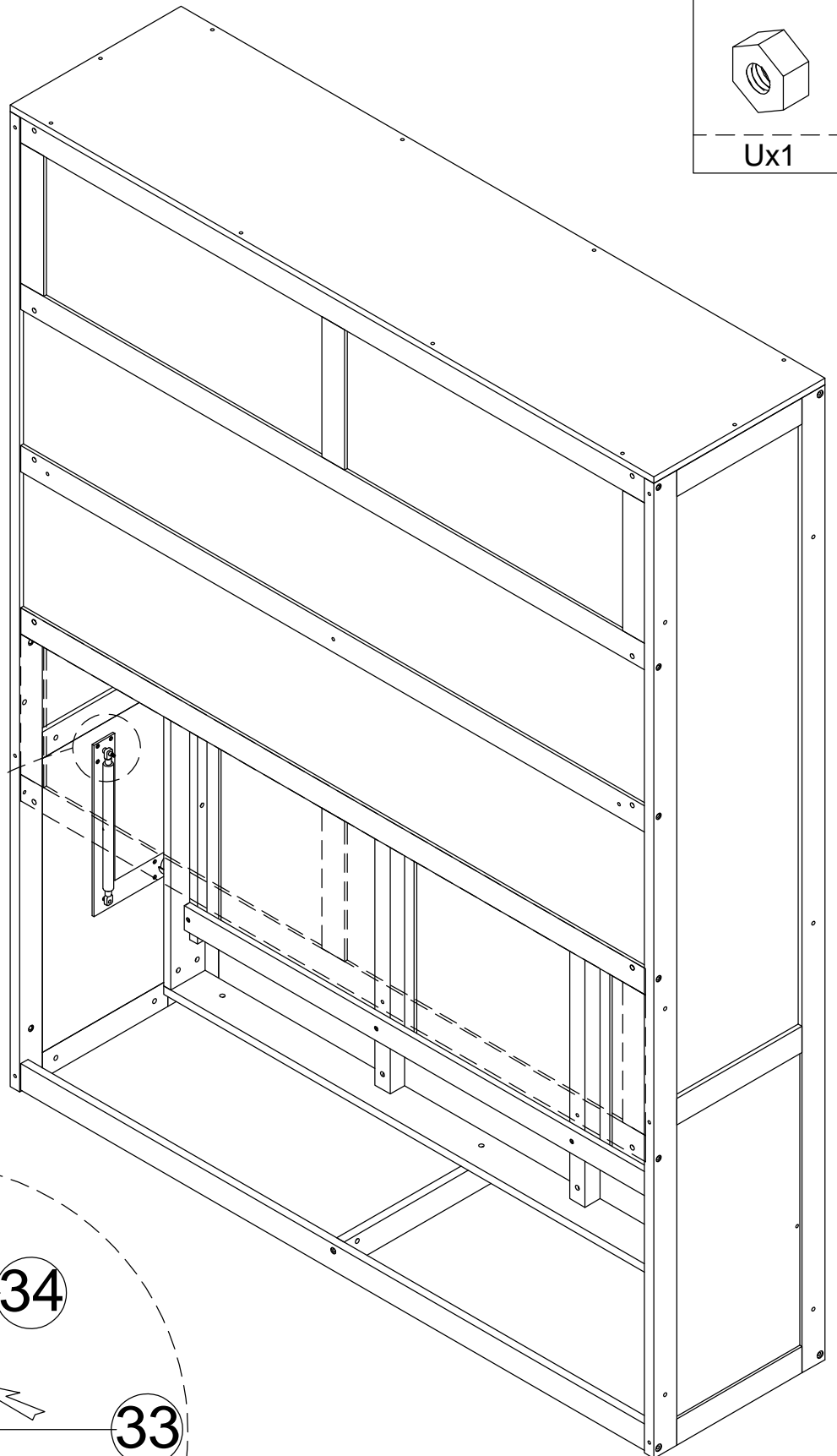

Four people are required to assemble and
move this model
Quatre personnes sont nécessaires pour
assembler et déplacer ce modèle

STEP 25-2:
ÉTAPE 25-2:

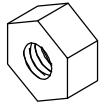

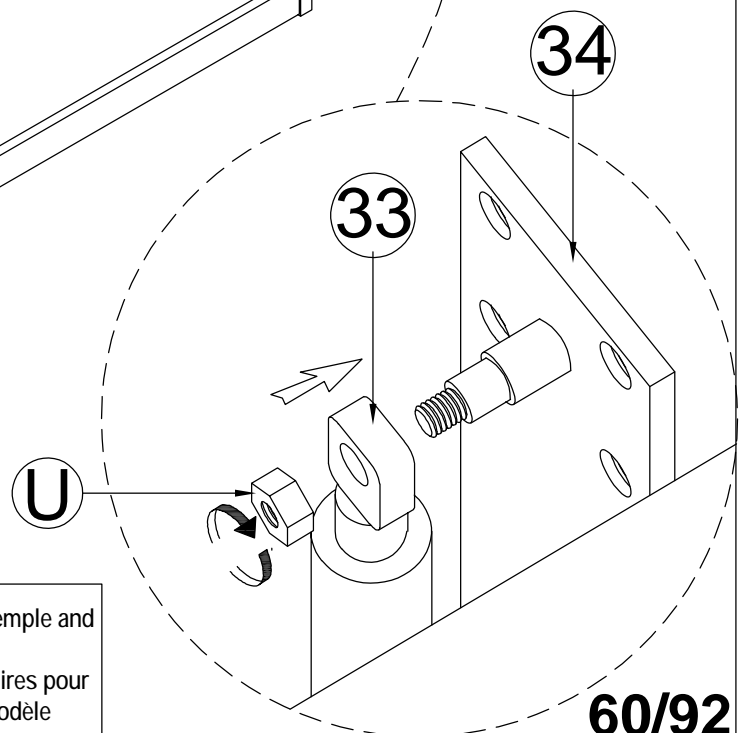
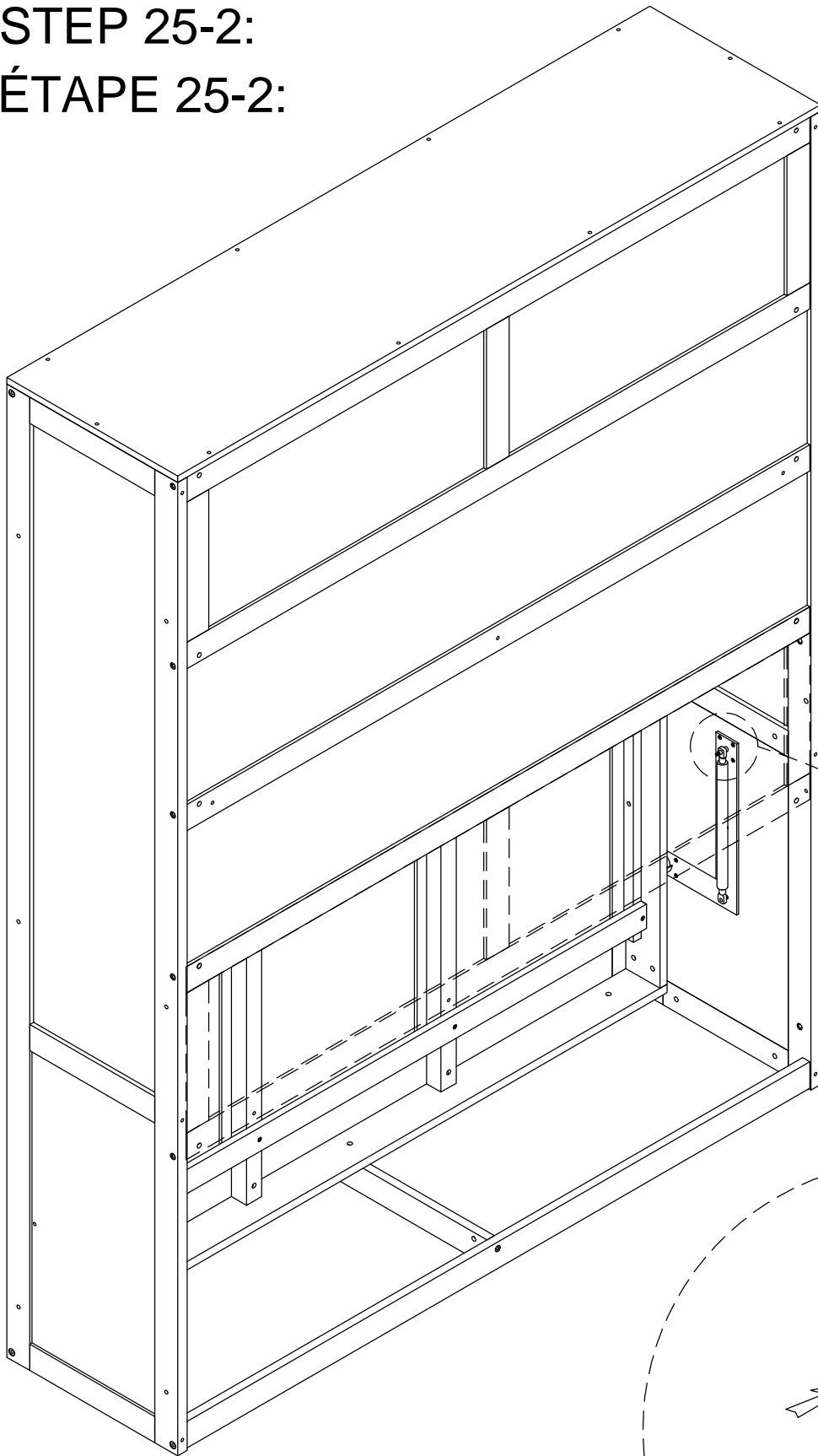

Ux1



Four people are required to assemble and
move this model
Quatre personnes sont nécessaires pour
assembler et déplacer ce modèle

STEP 26-1:
ÉTAPE 26-1:

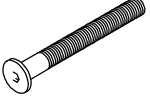
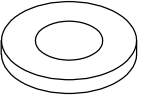
	Ø6x15mm 	Ø6x40mm 
ACx1	Zx2	Yx2
		
		Sx2

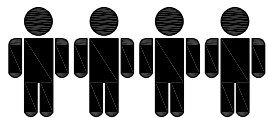
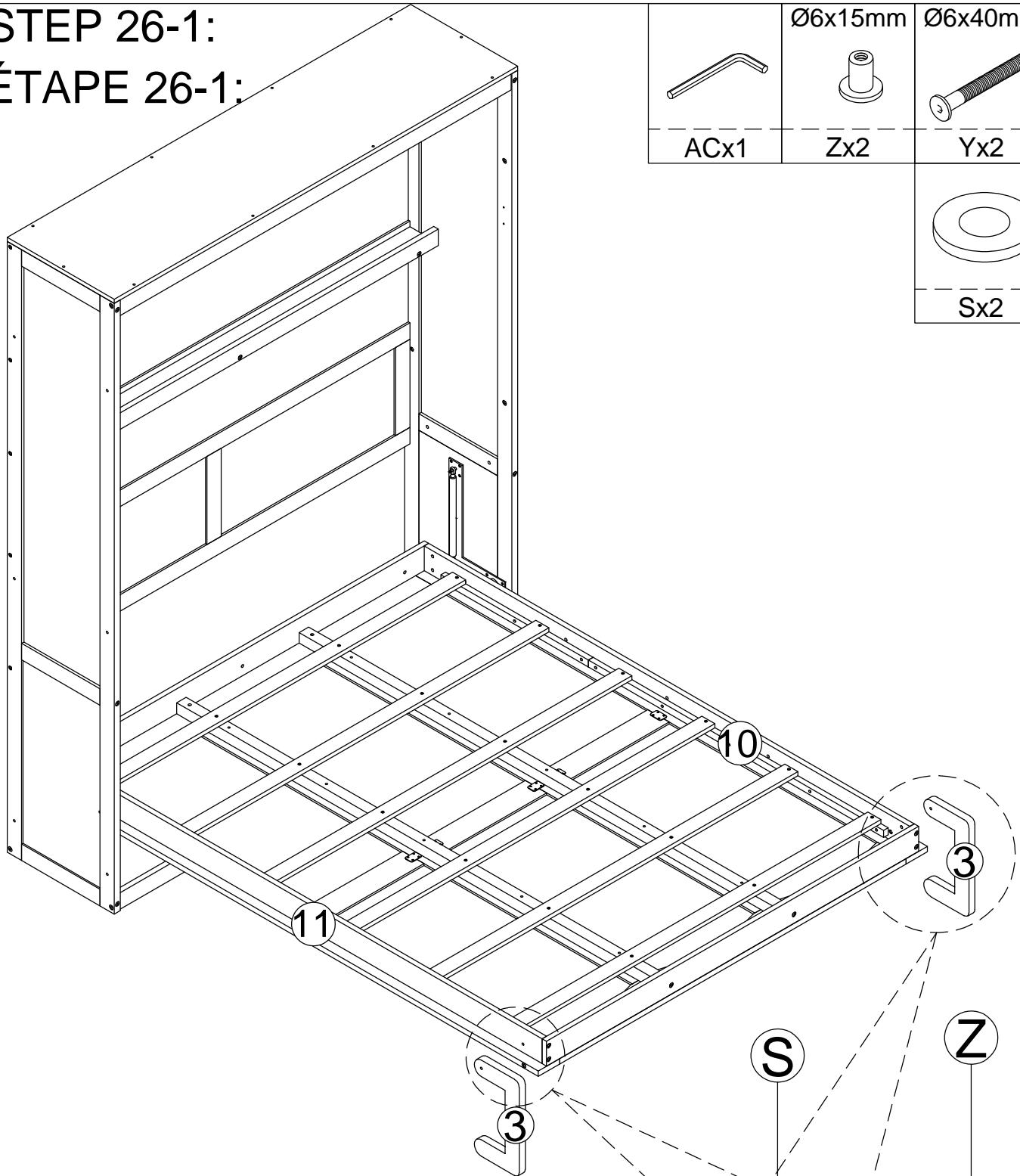

Four people are required to assemble and move this model
Quatre personnes sont nécessaires pour assembler et déplacer ce modèle

AC

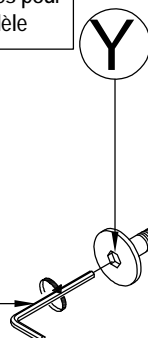

STEP 26-2:
ÉTAPE 26-2:

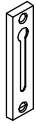
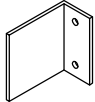
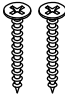
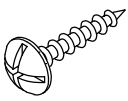
		$\text{Ø}4 \times 15 \text{mm}$
		
Fx1	Ex2	Gx4

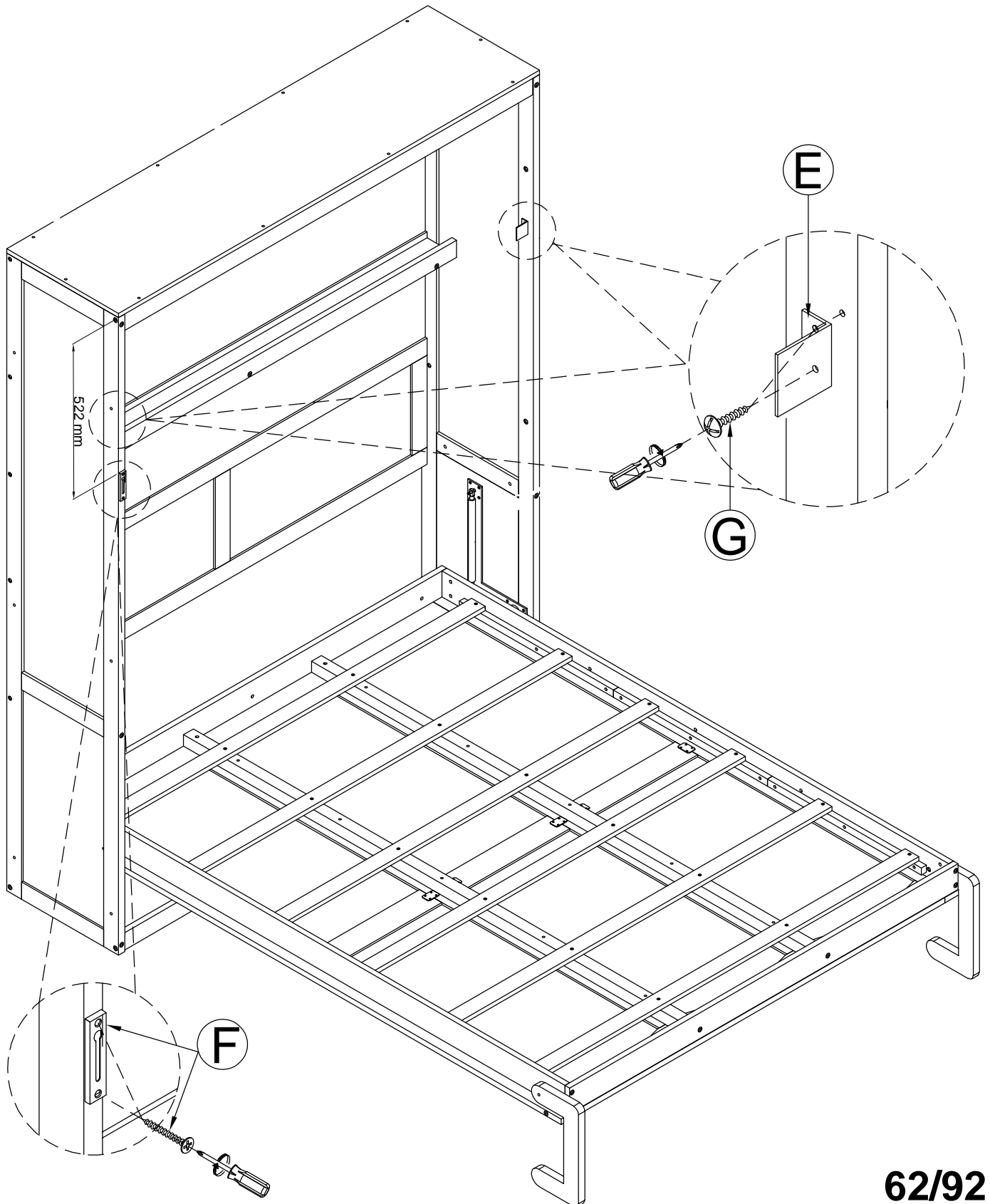

STEP 27:
ÉTAPE 27:

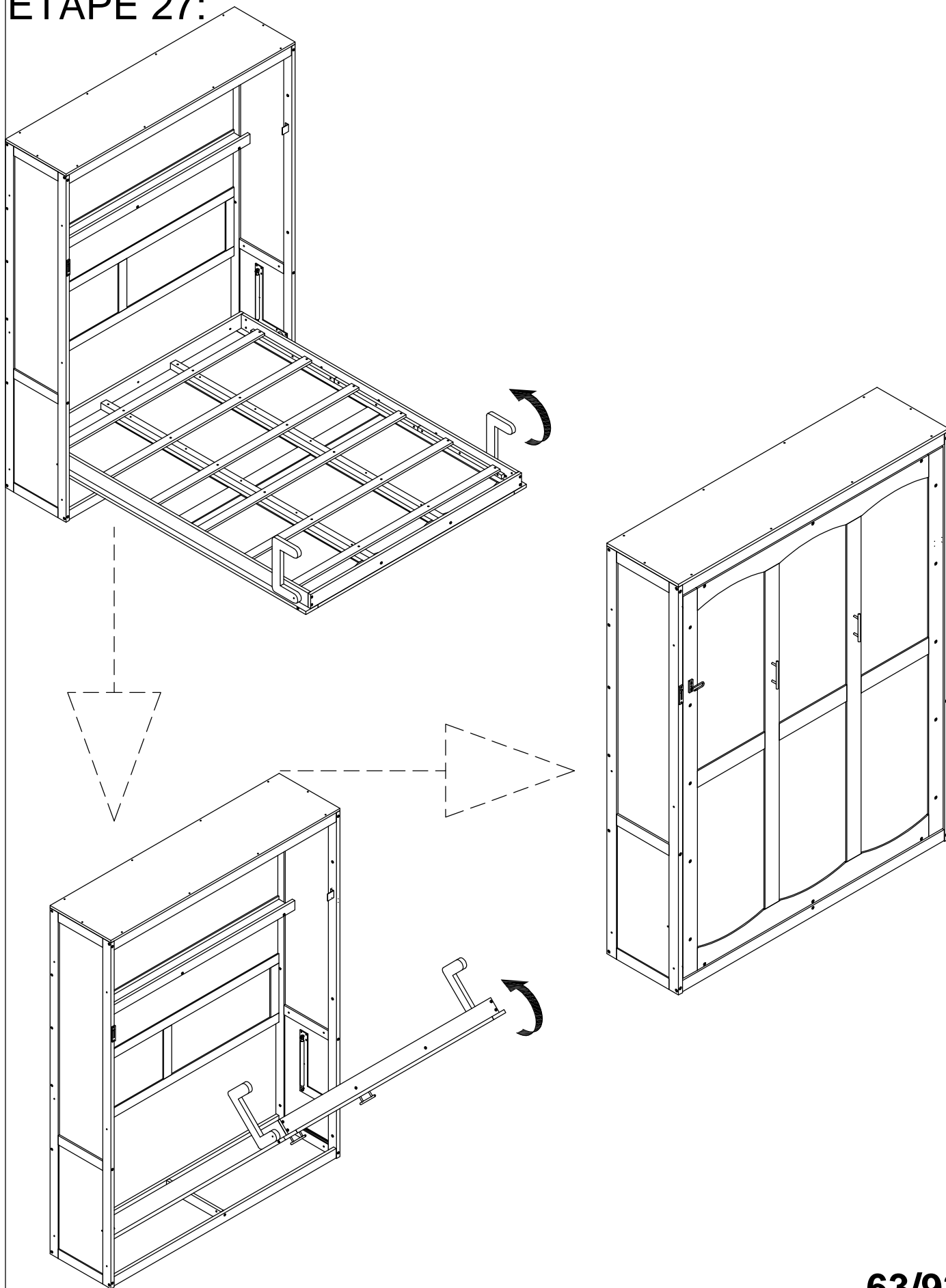

WALL ANCHORING INSTRUCTIONS INSTRUCTIONS DE FIXATION MURALE

Determine the position of the bed in the room
Déterminez la position du lit dans la pièce.

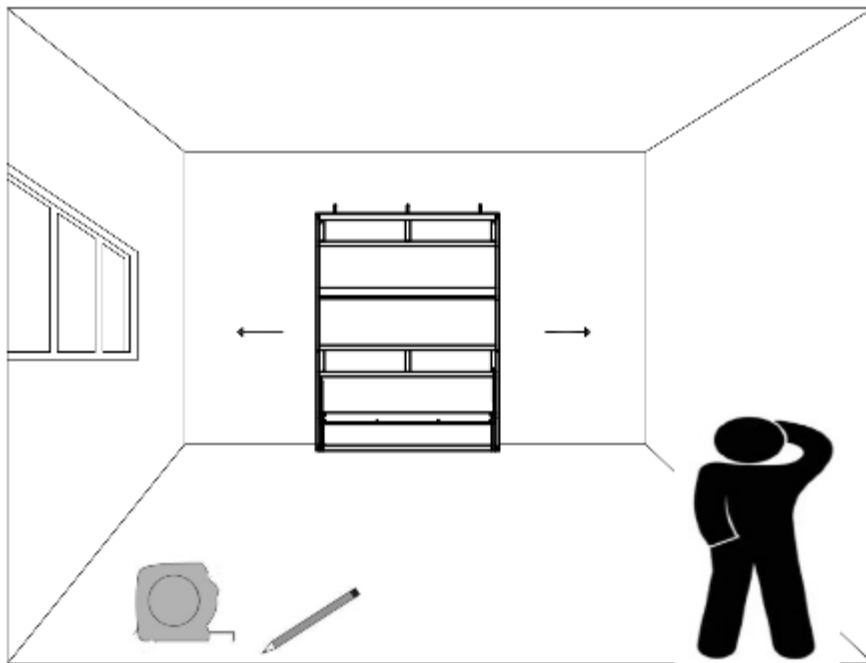

Put the bed back in its place. Please keep it vertical and horizontal
Remettez le lit à sa place. Veuillez le garder vertical et horizontal.

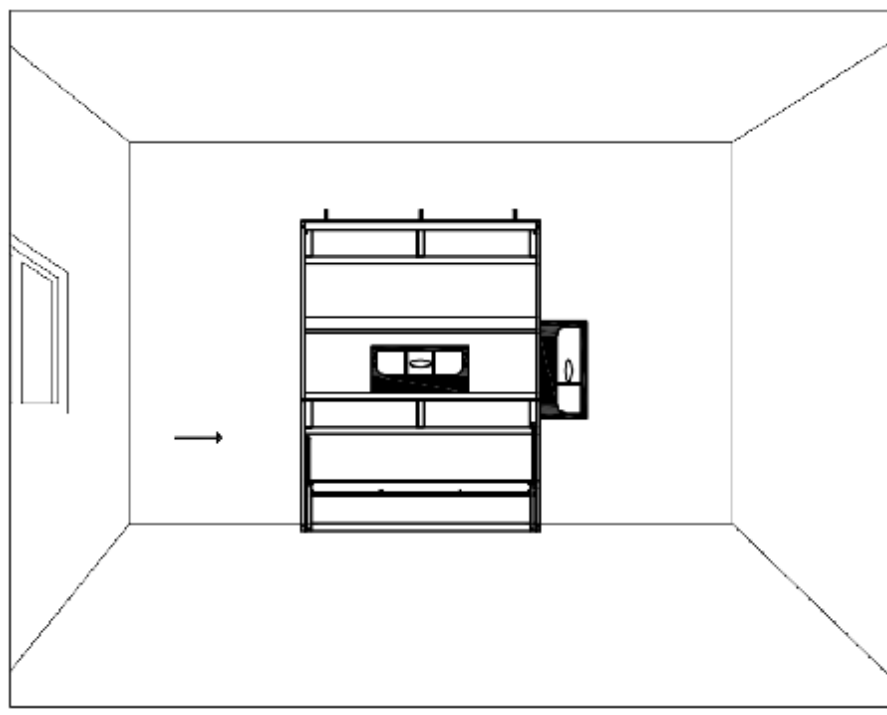

- ③** Mark 06 drilling hole positions on the wall corresponding to the part (W).
 Marquez 06 positions de perçage sur le mur correspondant à la pièce (W).

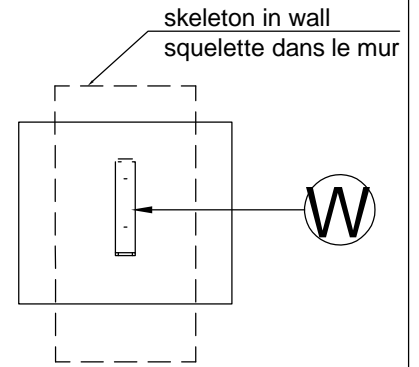
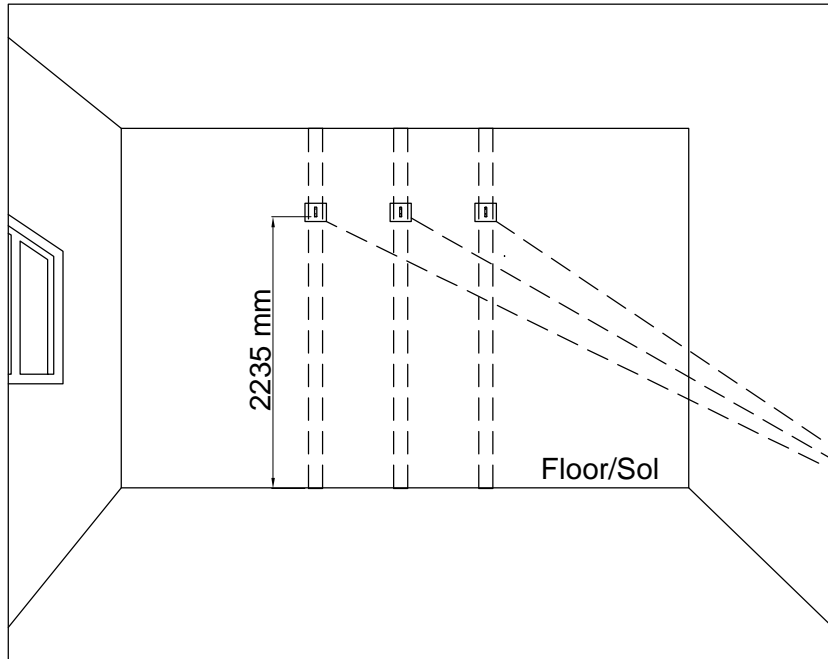

Align the Steel Bracket to match the Frame in the wall
 Alignez le support en acier avec le cadre du mur.

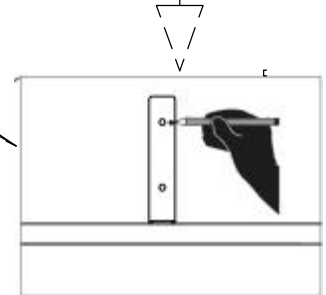

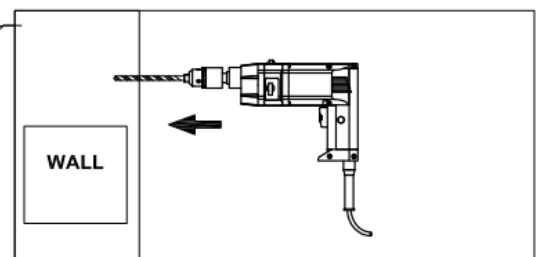
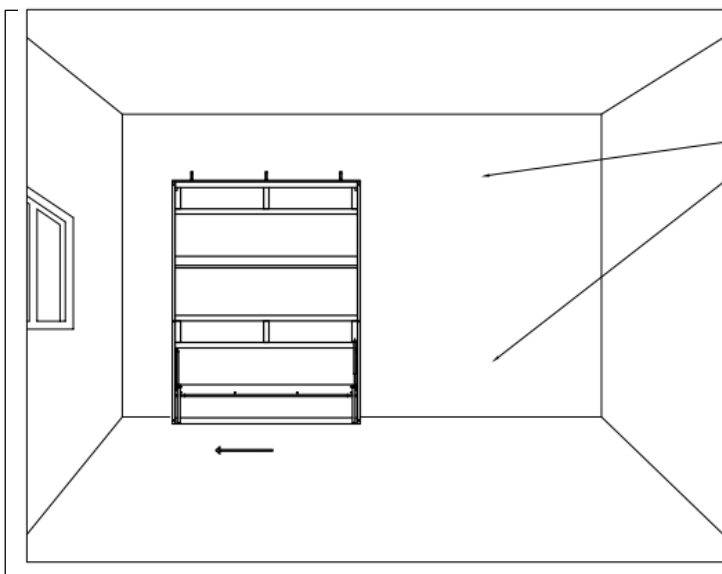

- ④** Move the bed again, then use a wall drill with an 8mm drill bit to drill into the marked positions, ensuring the hole depth exceeds 90mm.
 Déplacez à nouveau le lit, puis utilisez une perceuse murale avec un foret de 8 mm pour percer aux positions marquées, en veillant à ce que la profondeur des trous dépasse 90 mm.

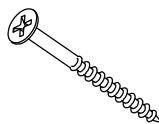

STEP 28: ÉTAPE 28:

*-Position on the wall to align the plastic stopper (AA) with the hole positions on the part (W) at the bed's location
 *-Positionner sur le mur pour aligner le bouchon en plastique (AA) avec les positions des trous sur la pièce (W) à l'emplacement du lit

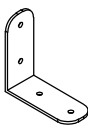
M5x80mm		
ABx6		AAx6
		
		Wx3

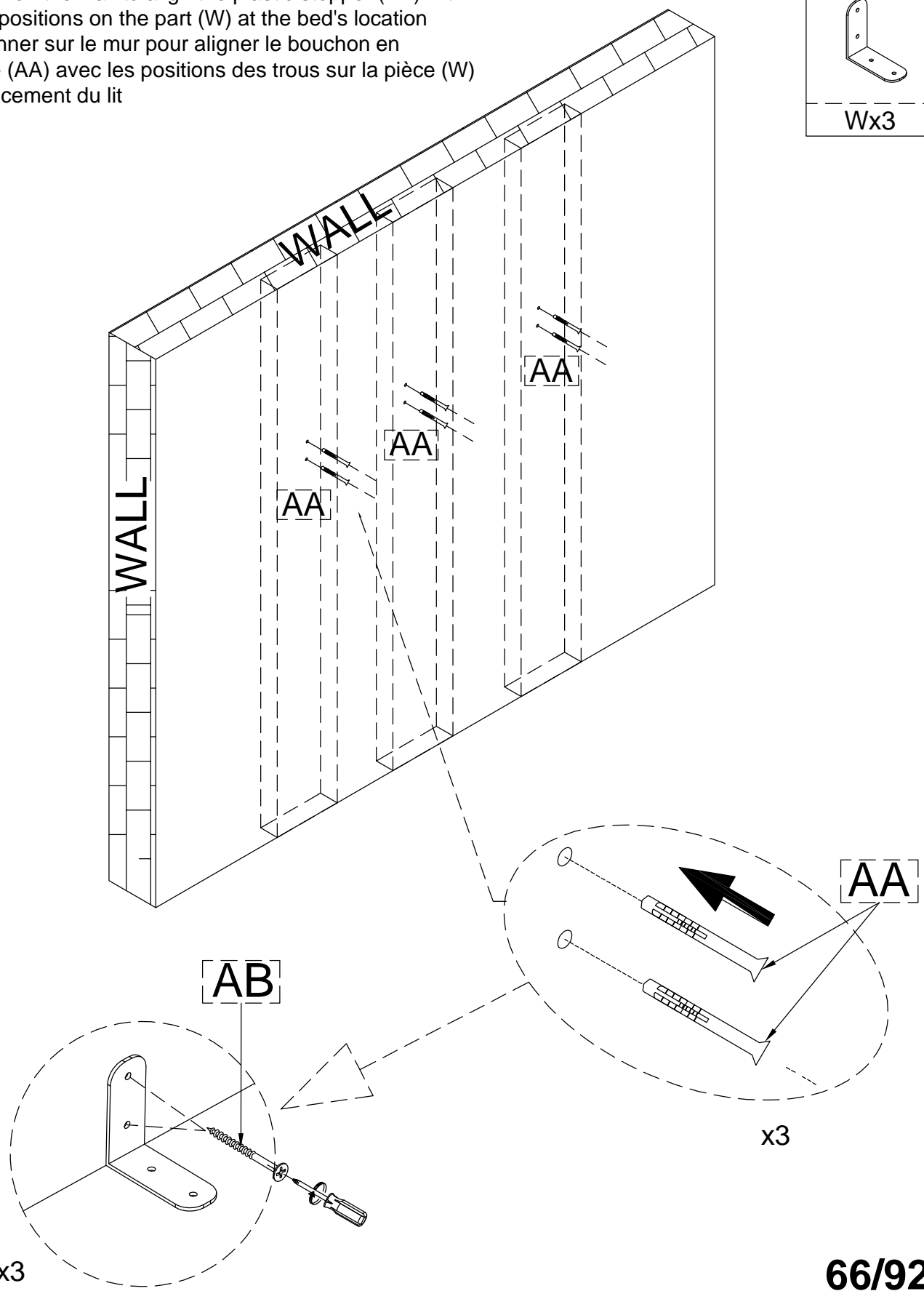

x3

x3

STEP 29:

ÉTAPE 29:

G

Ø4x15mm

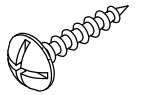

Gx6

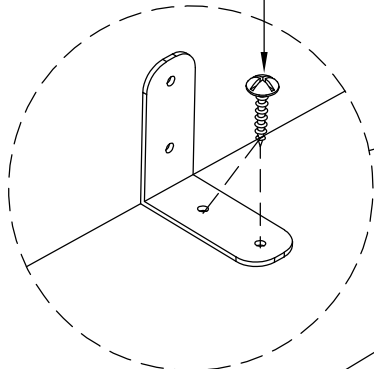

x3

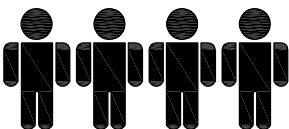
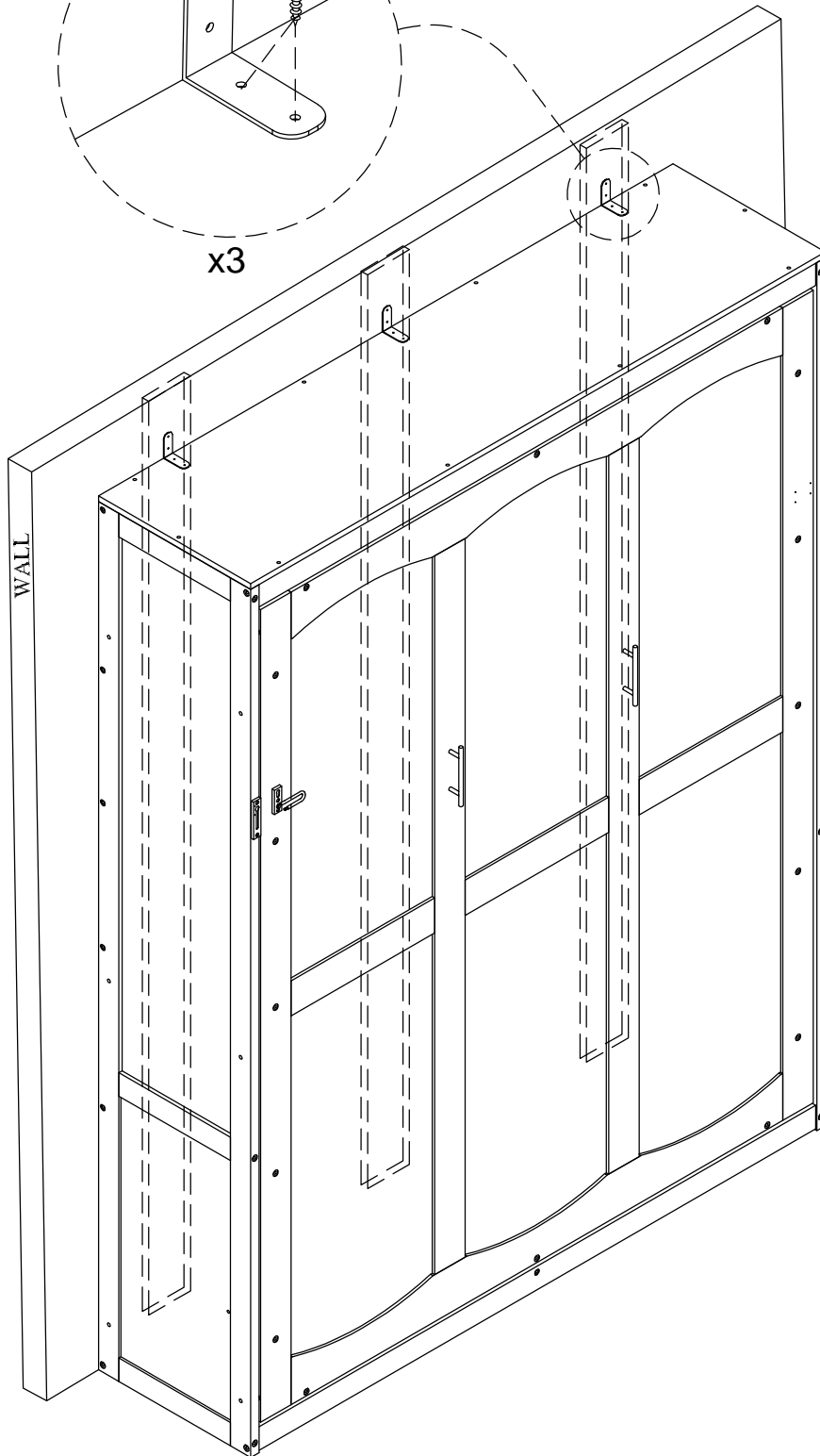

Four people are required to assemble and move this model

Quatre personnes sont nécessaires pour assembler et déplacer ce modèle

67/92

STEP 30-1:

ÉTAPE 30-1:

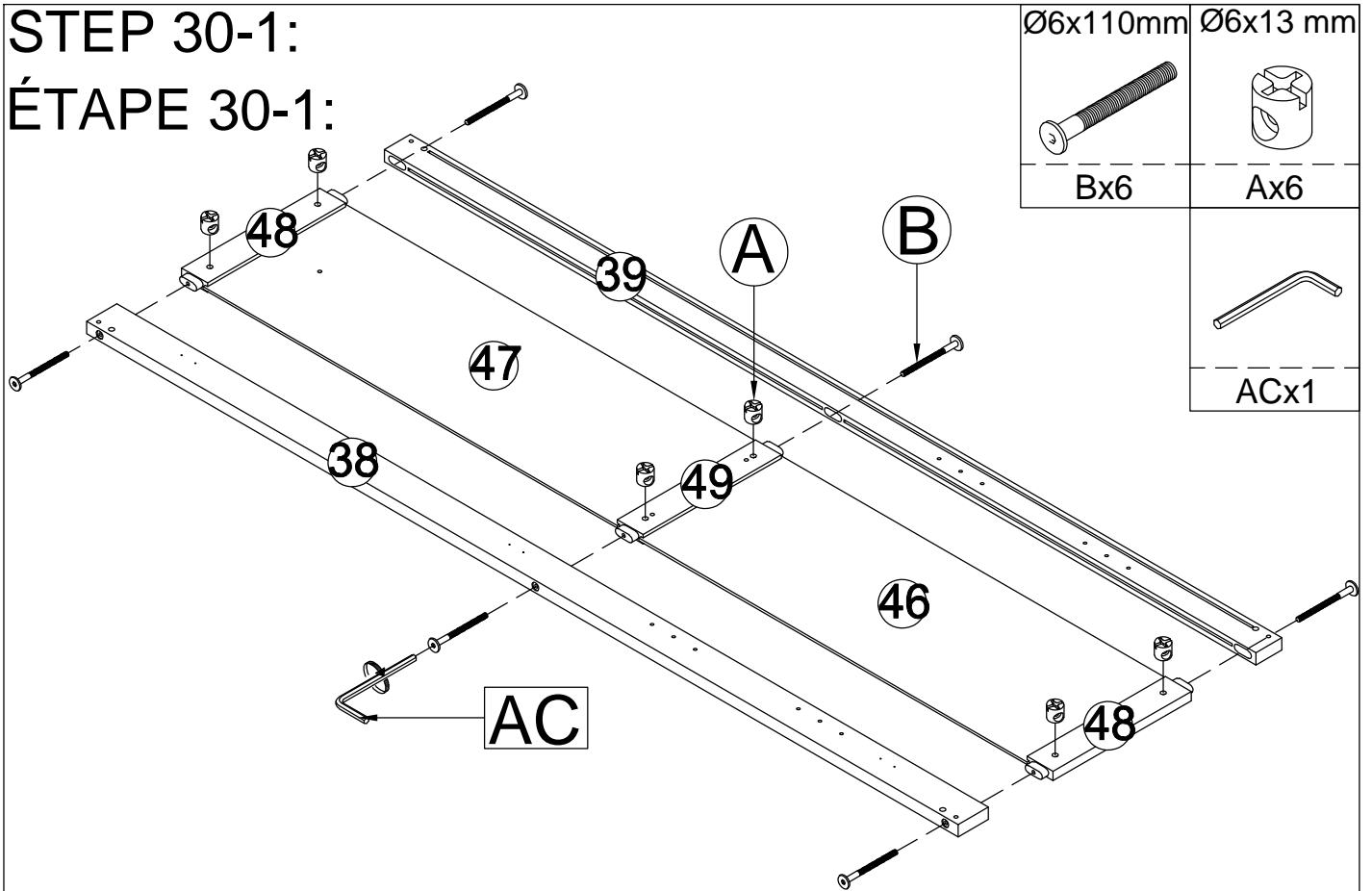

STEP 30-2:

ÉTAPE 30-2:

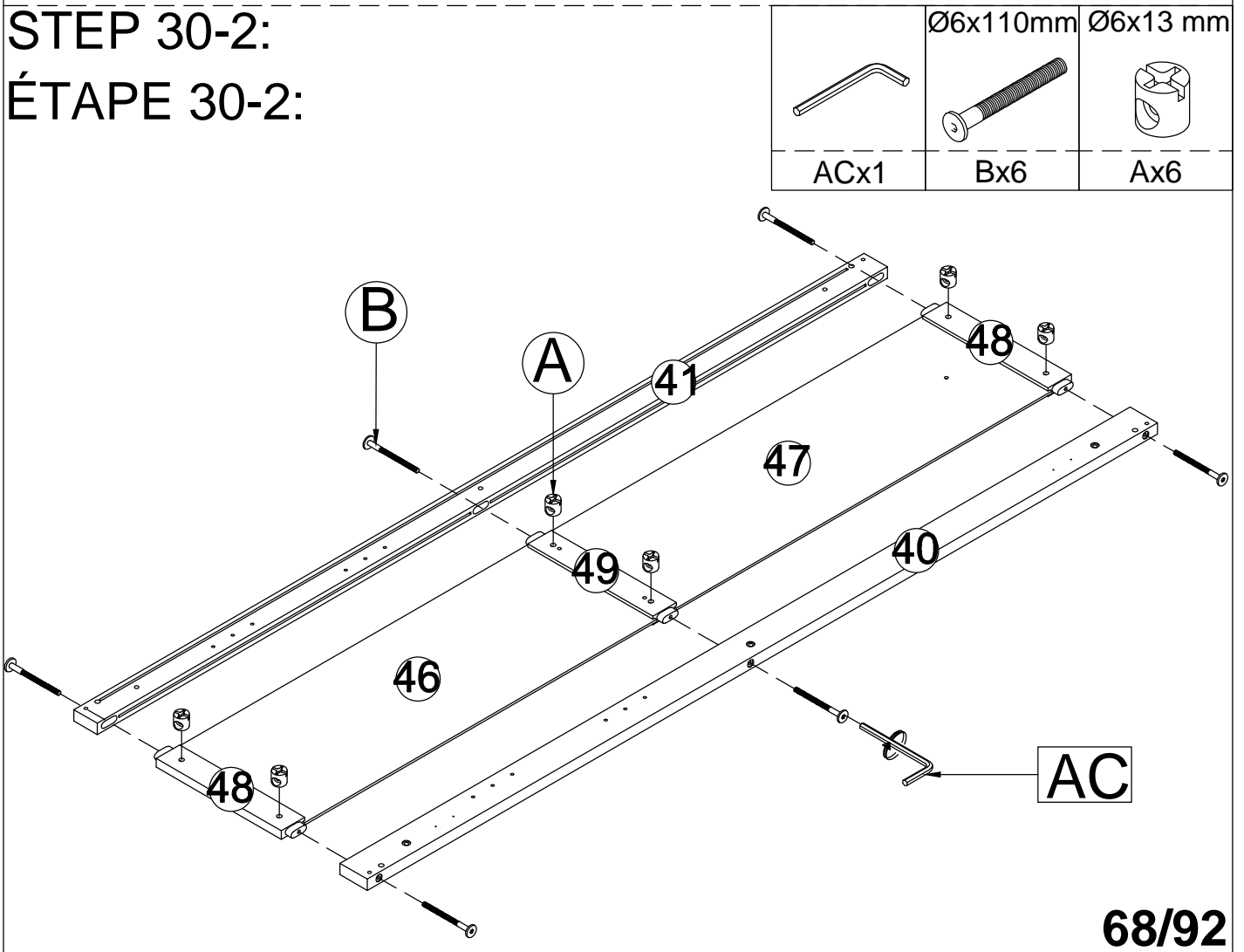

STEP 31:

ÉTAPE 31:

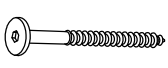
	Ø6x70mm
ACx1	
	AFx4

AF

AC

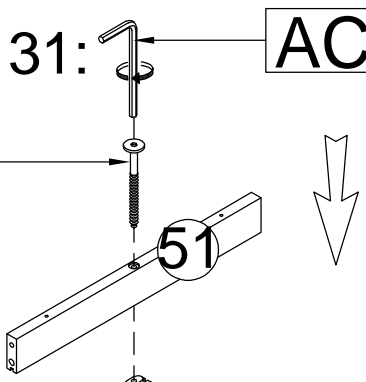

51

D1 > D2

x2

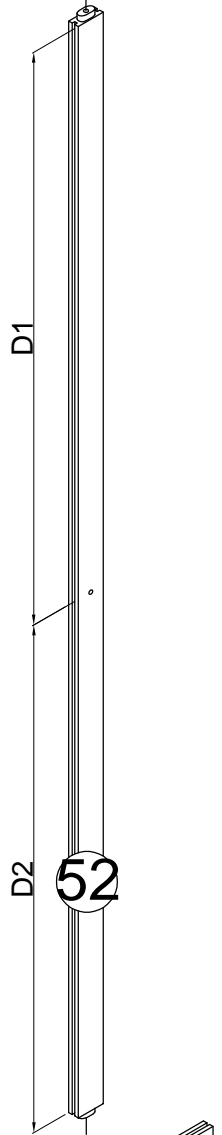

52

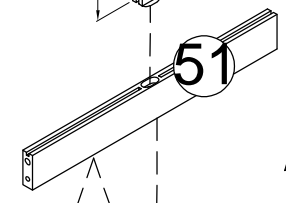

Floor/Sol

51

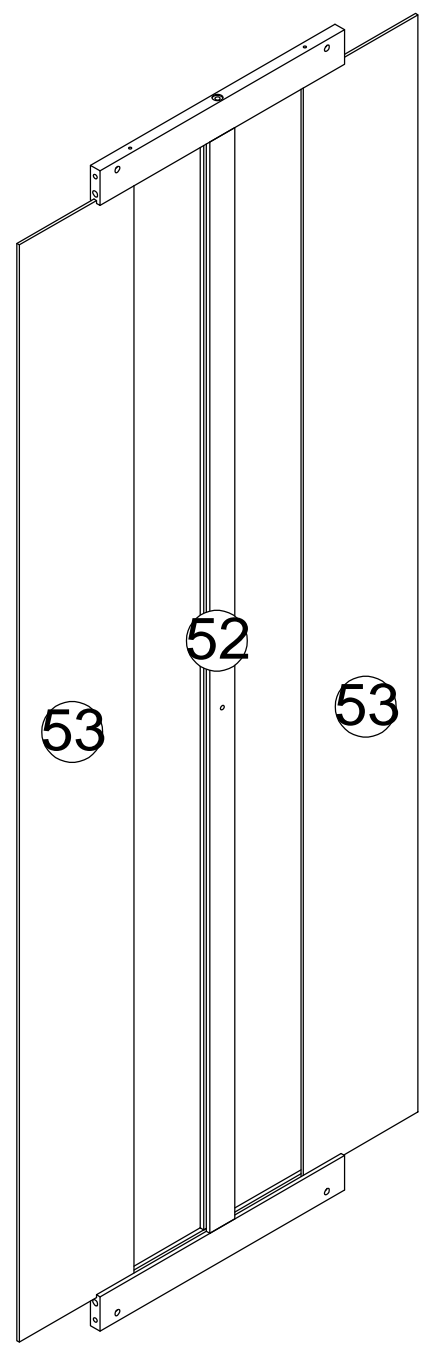
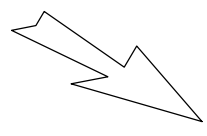

53

52

53

x2

STEP 32:
ÉTAPE 32:

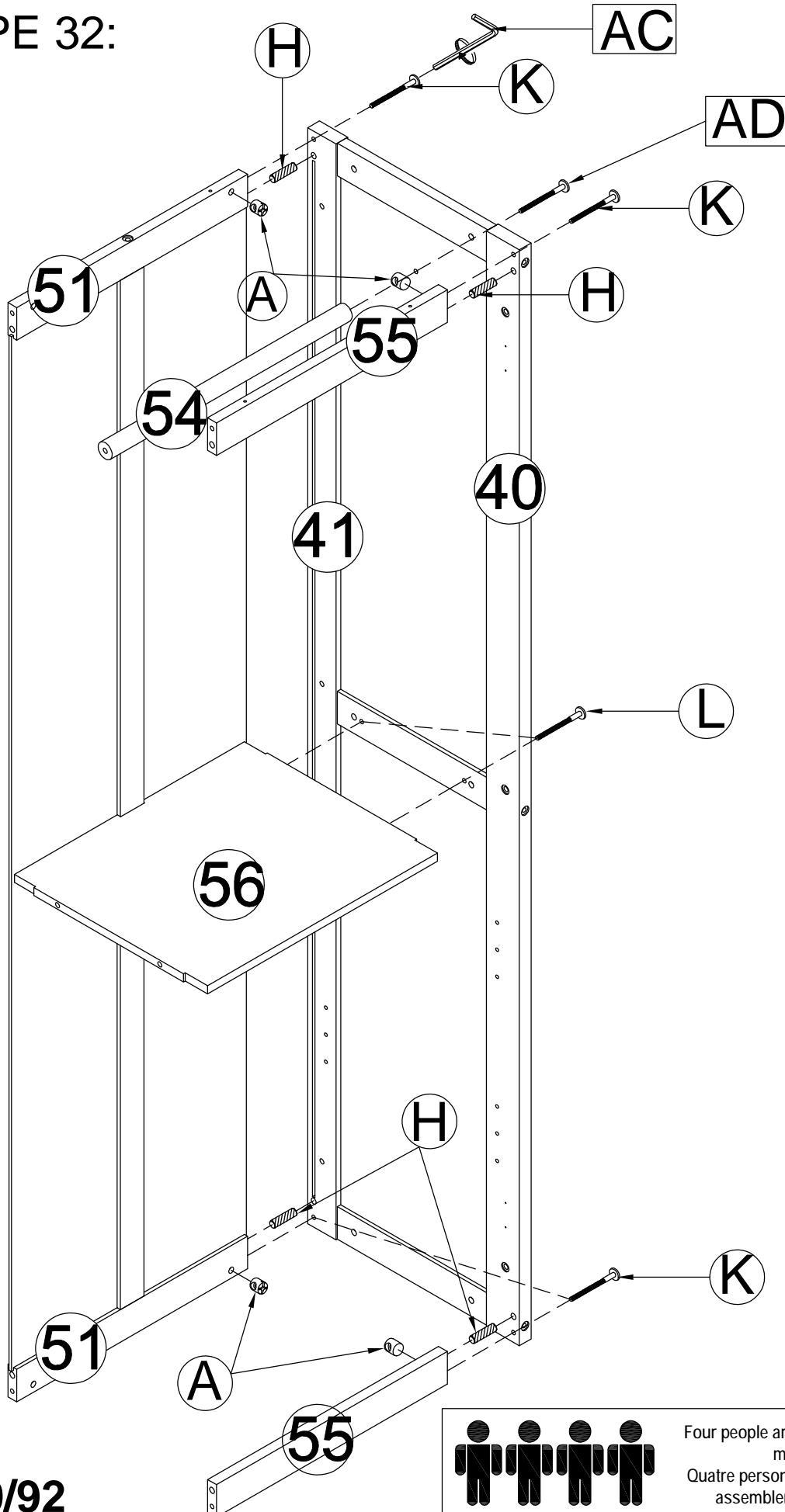

Ø6x13 mm	
Ax4	
Ø10x40mm	
Hx4	
Ø6x70mm	
Kx4	
Ø6x30mm	
Lx2	
Ø6x20mm	
ADx1	
ACx1	

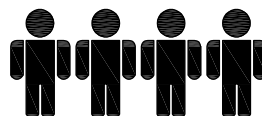

Four people are required to assemble and move this model
Quatre personnes sont nécessaires pour assembler et déplacer ce modèle

STEP 33:

ÉTAPE 33:

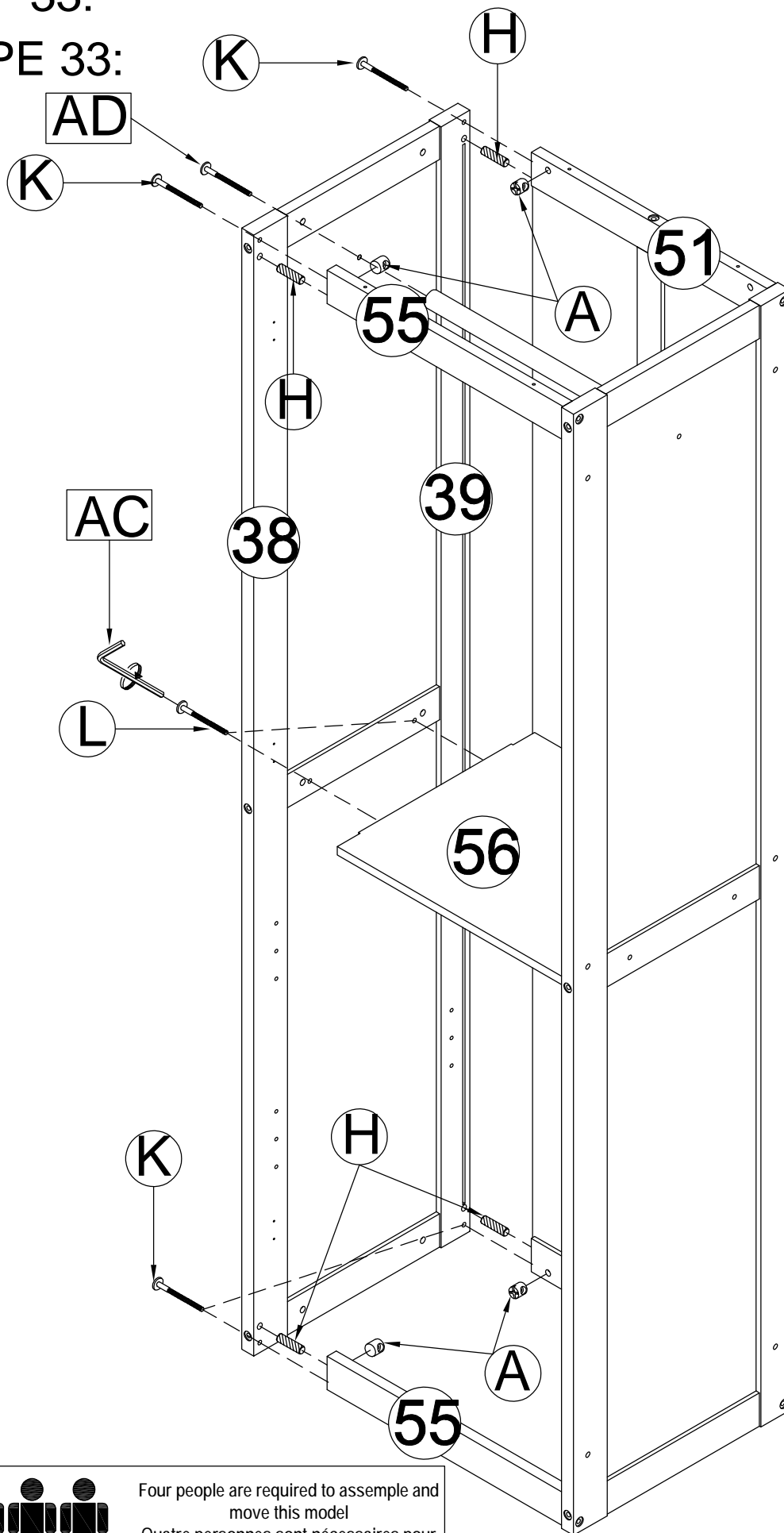

Ø6x13 mm



Ax4

Ø10x40mm

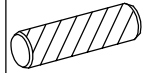

Hx4

Ø6x70mm

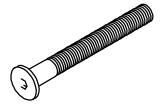

Kx4

Ø6x30mm

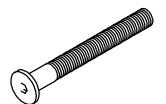

Lx2

Ø6x20mm

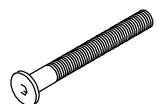

ADx1







ACx1

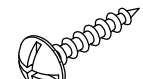

Four people are required to assemble and move this model
Quatre personnes sont nécessaires pour assembler et déplacer ce modèle

STEP 34:
ÉTAPE 34:

	$\text{\O}6 \times 40 \text{mm}$ 	$\text{\O}4 \times 20 \text{mm}$ 	$\text{\O}6 \times 30 \text{mm}$ 
ACx1	Mx4	Cx2	Lx1

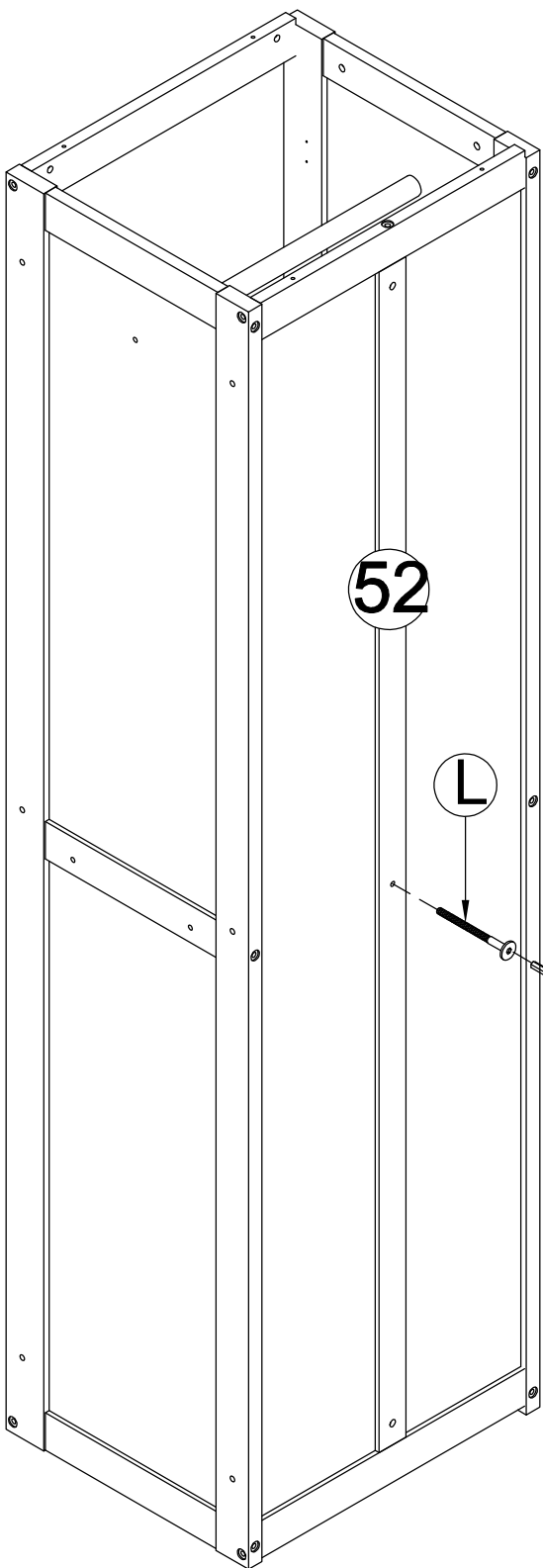

Back View
Vue arrière

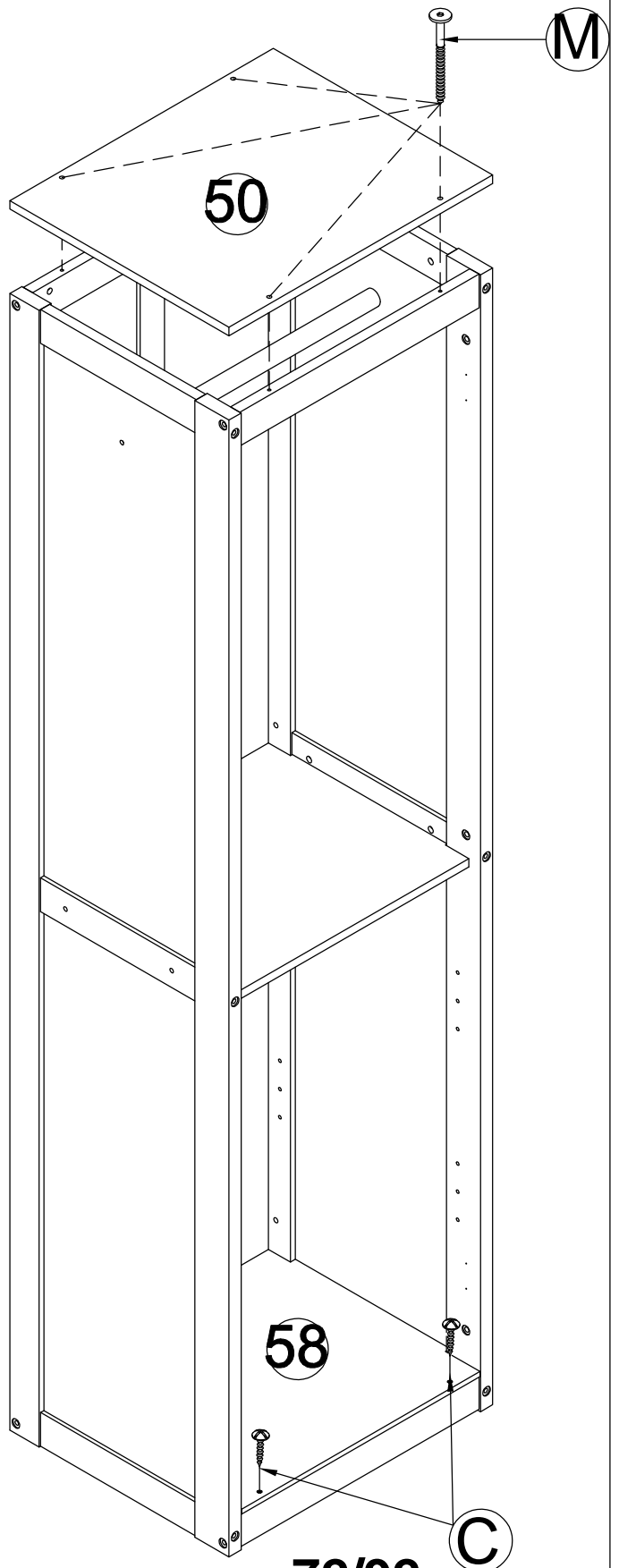

STEP 35:
ÉTAPE 35:

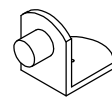

AEx8

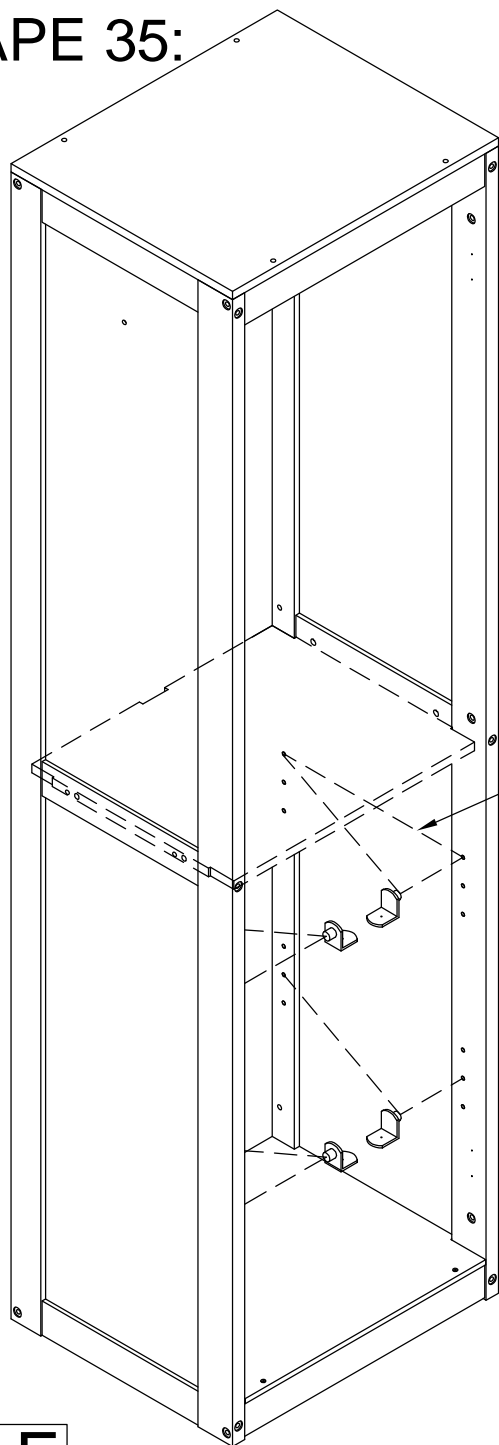

straight/droite

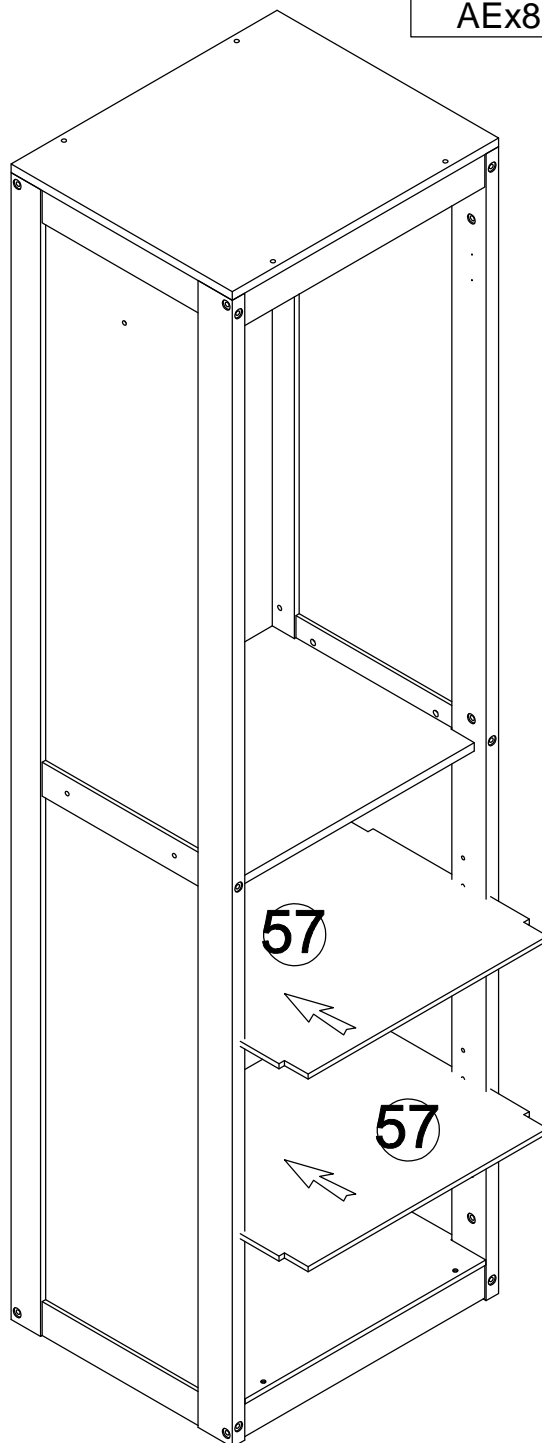

AE

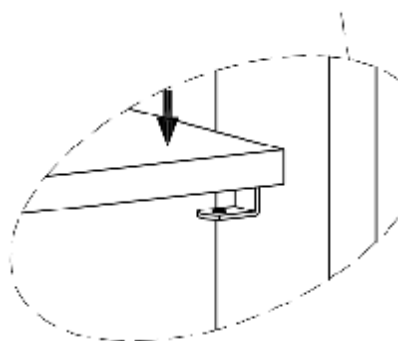
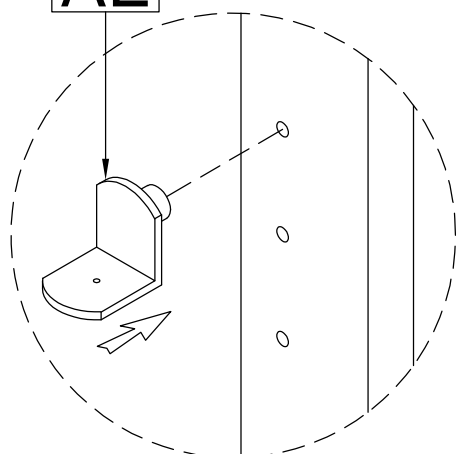

STEP 36:
ÉTAPE 36:

Ø6x70mm

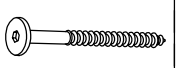

AFx6



ACx1

AF

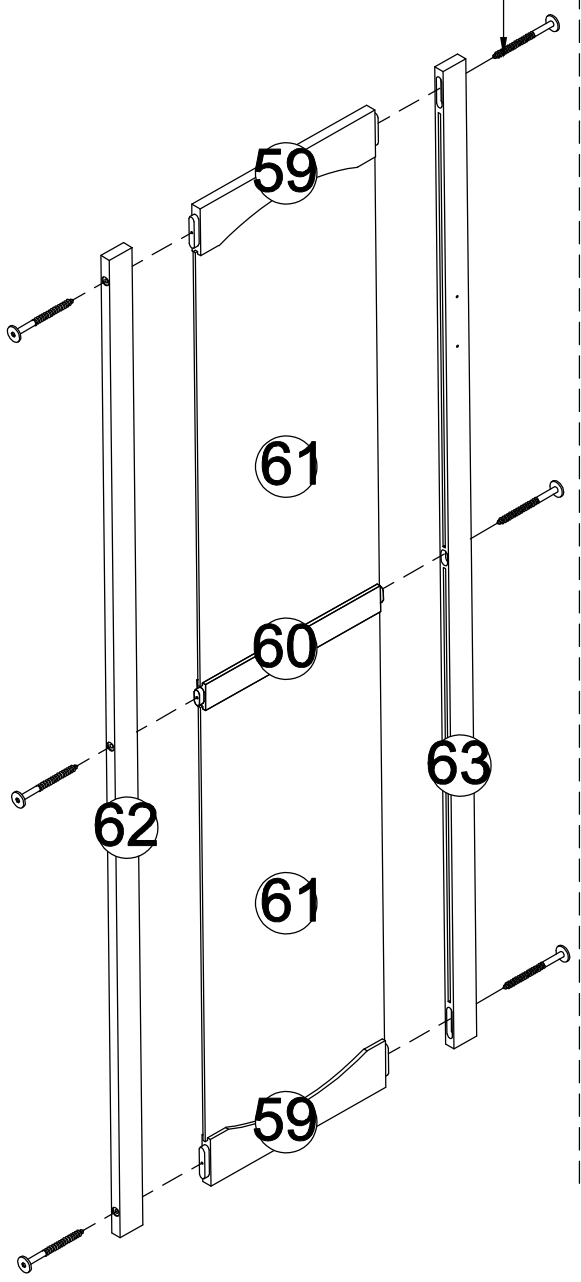

M3.5x12



AHx4



AGx2

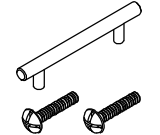

Rx1

Ø4x15mm

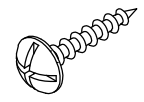

Gx6

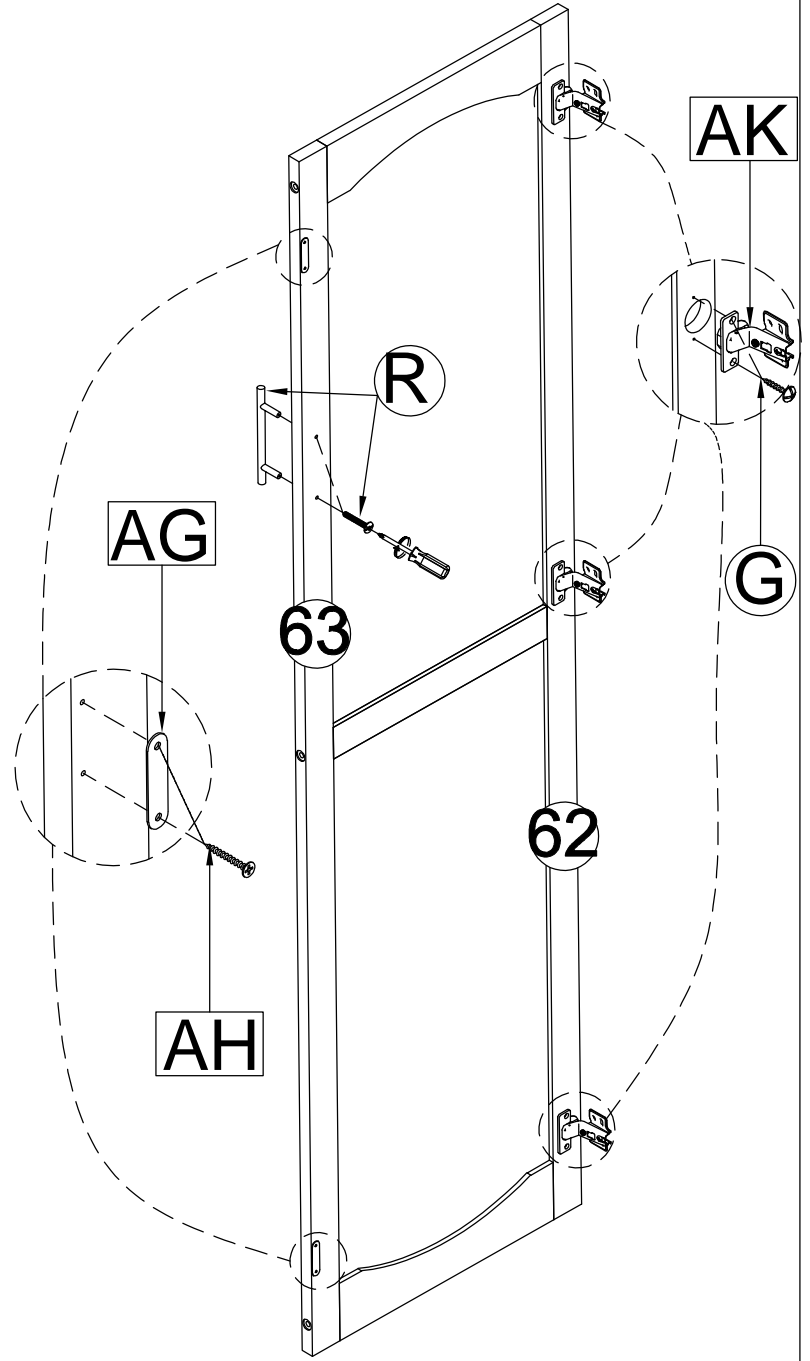

AK

R

AG

63

G

62

AH

STEP 37:
ÉTAPE 37:

Ø4x15mm

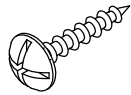

Gx4

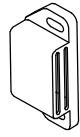

ALx2

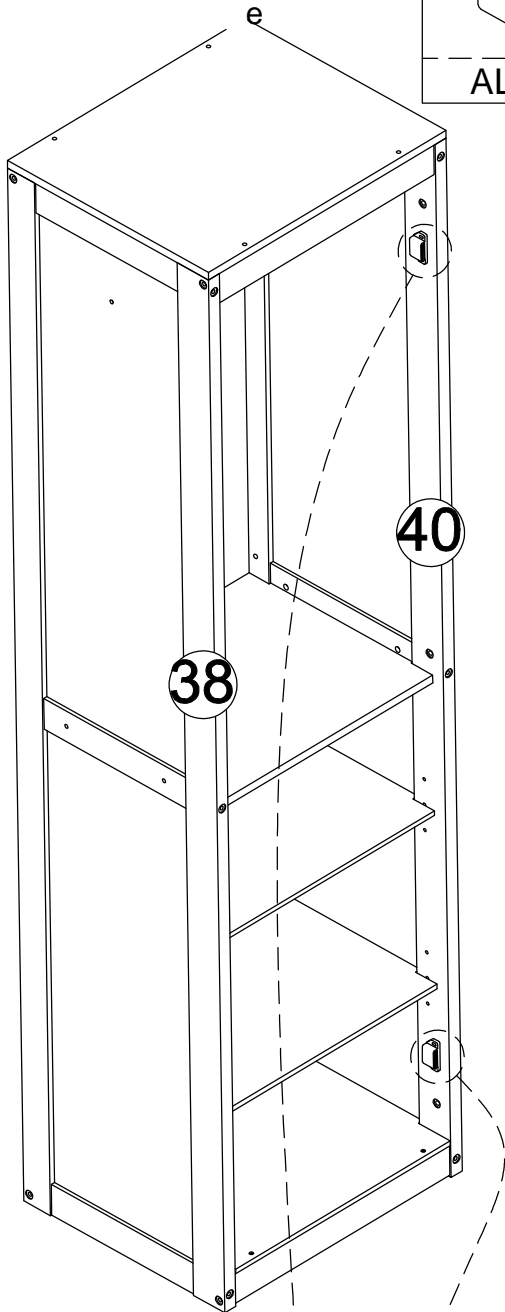

STEP 38:
ÉTAPE 38:

Ø4x20mm

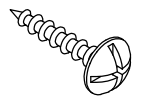

Cx12

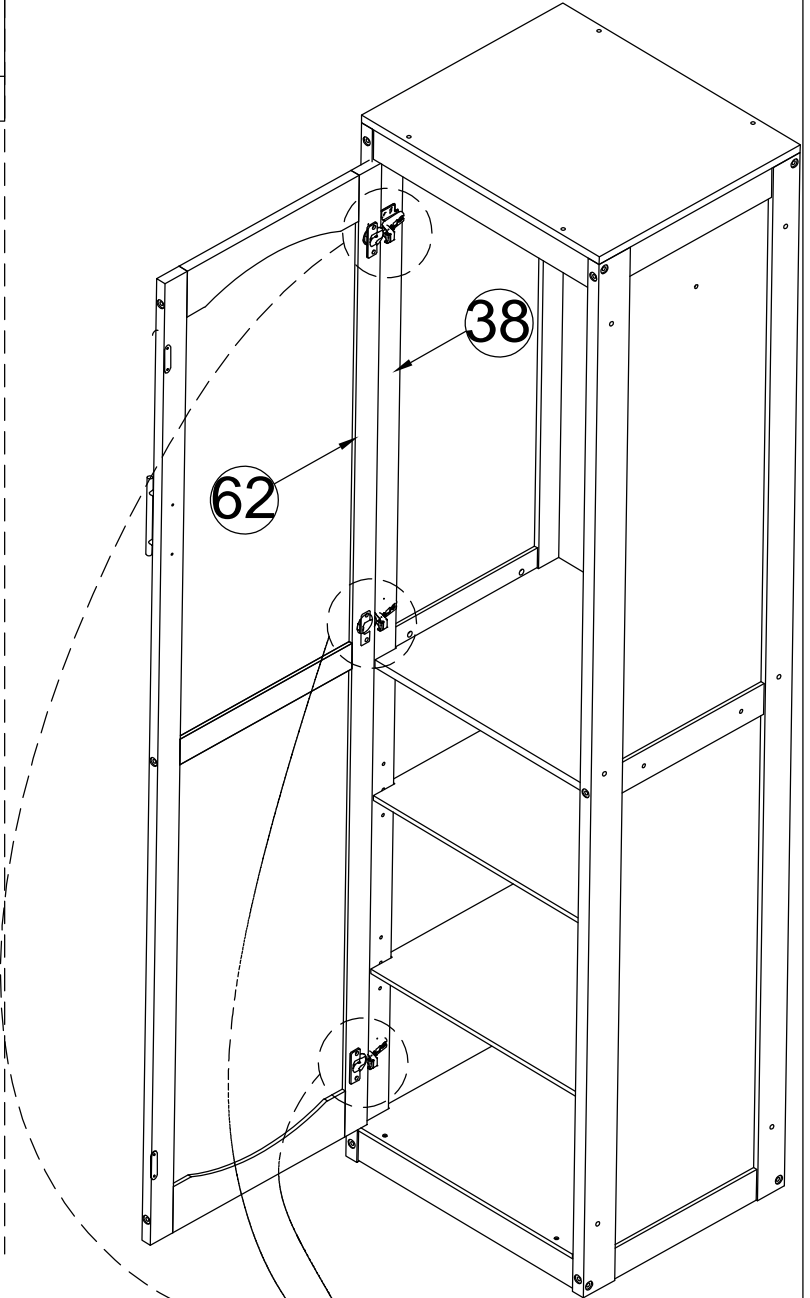

AL

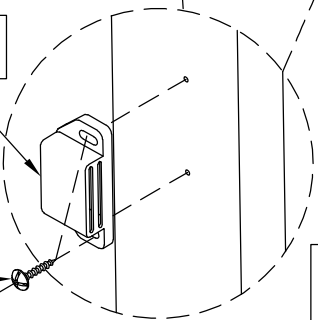

C

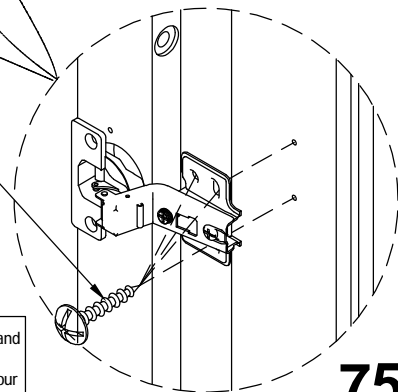

Four people are required to assemble and move this model
Quatre personnes sont nécessaires pour assembler et déplacer ce modèle

STEP 39-1:

ÉTAPE 39-1:

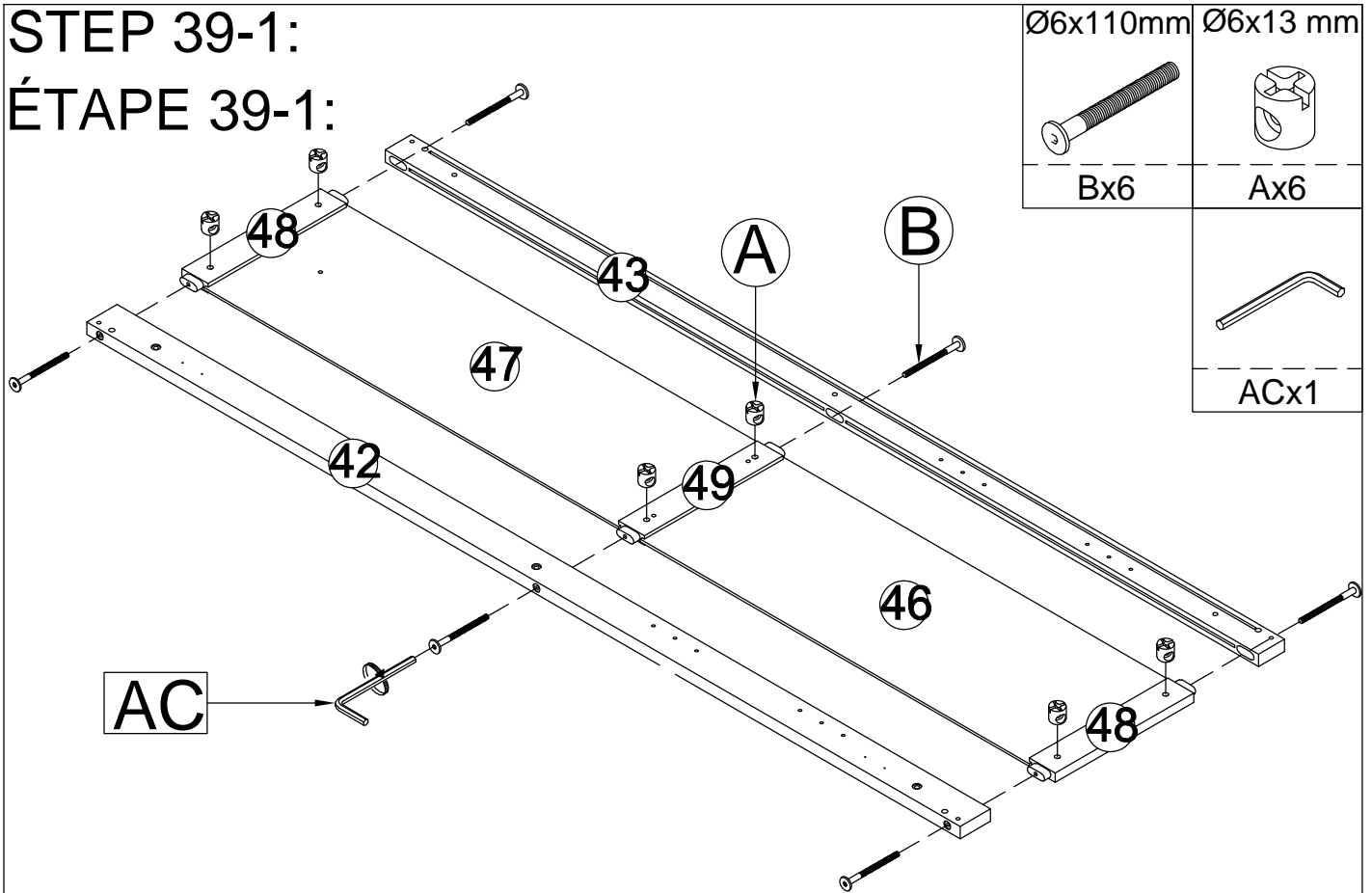



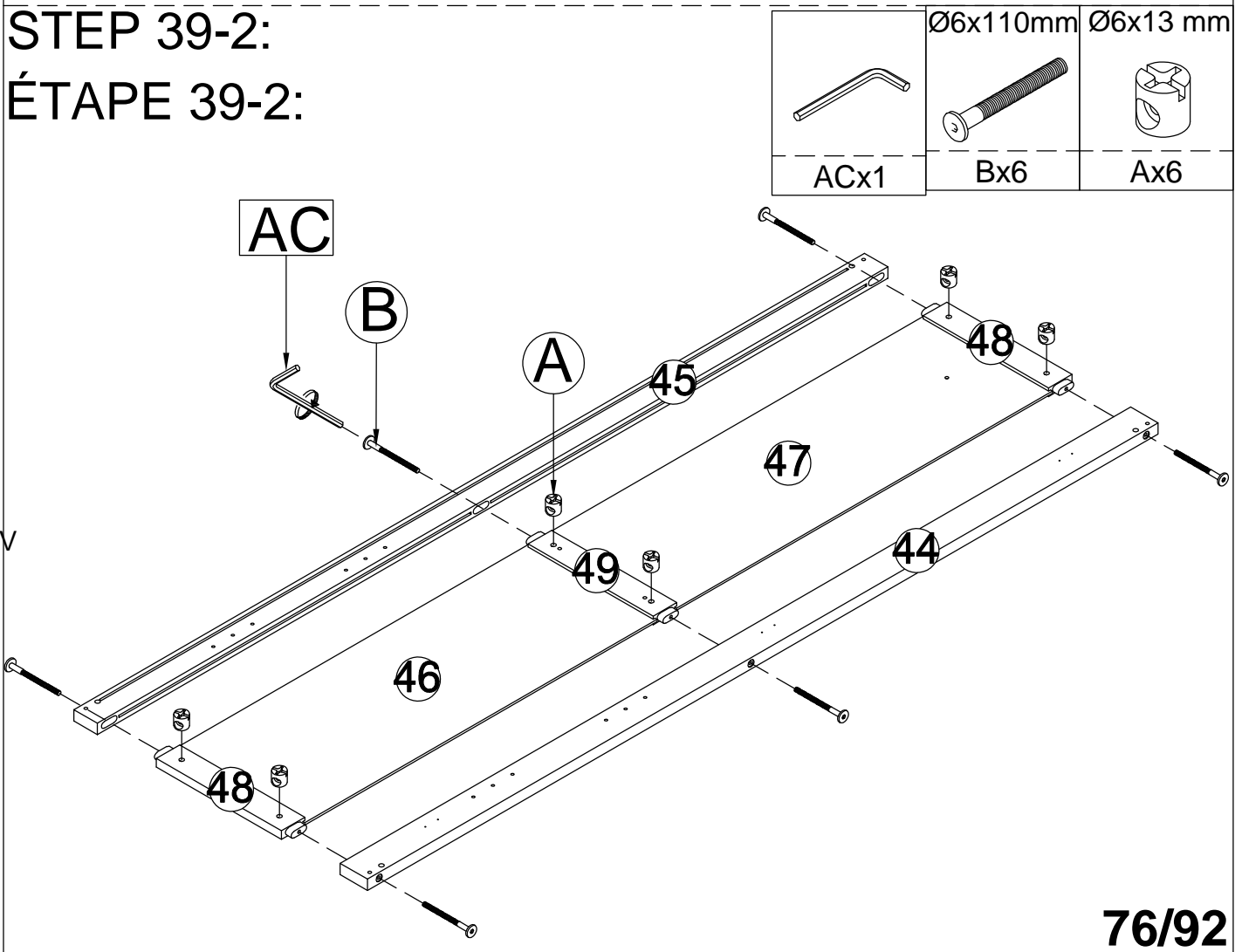

STEP 39-2:

ÉTAPE 39-2:

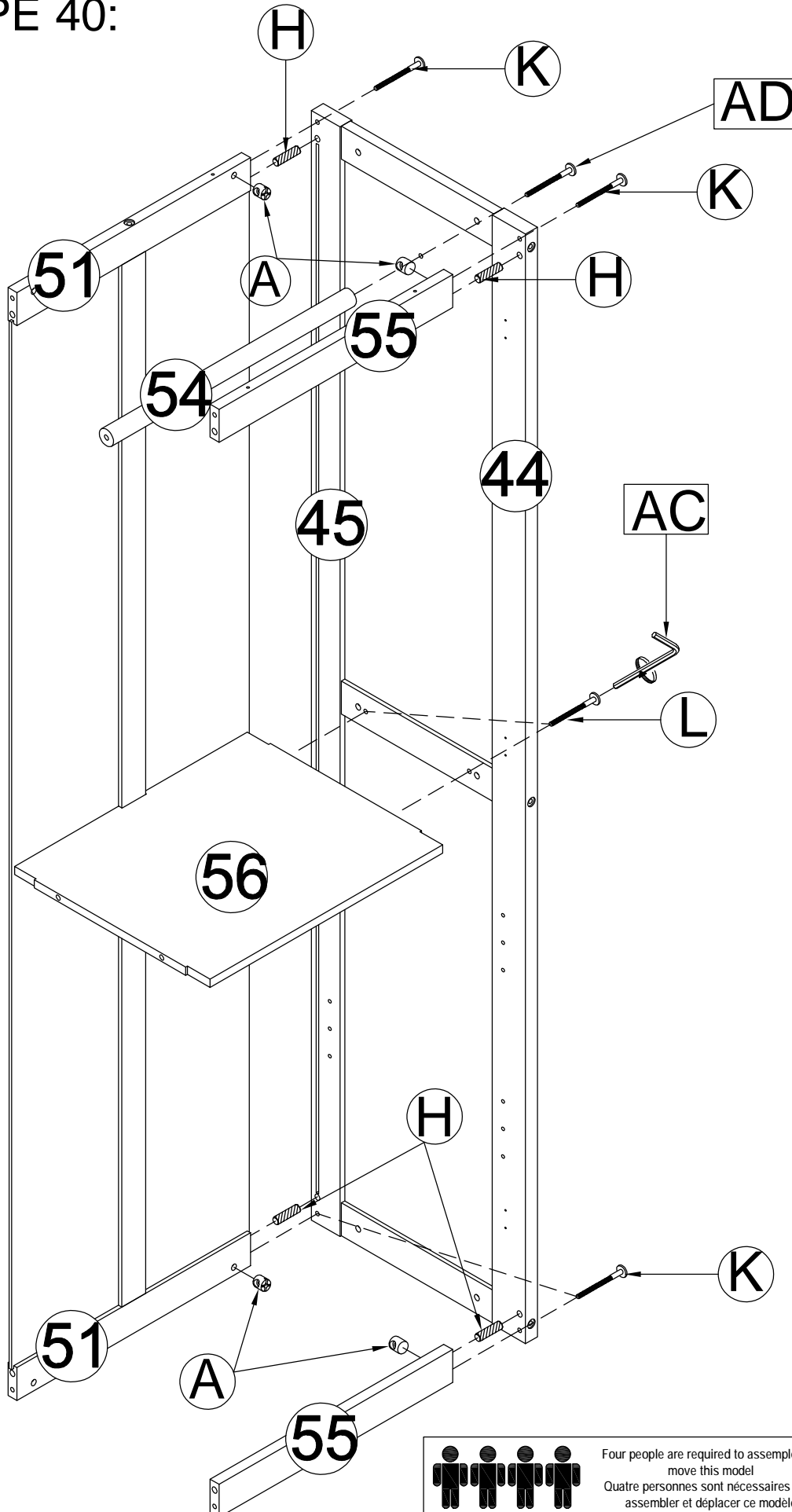

STEP 40:
ÉTAPE 40:

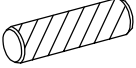
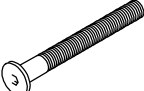
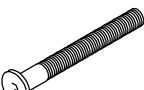
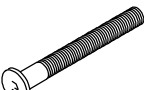

Ø6x13 mm	
Ax4	
Ø10x40mm	
Hx4	
Ø6x70mm	
Kx4	
Ø6x30mm	
Lx2	
Ø6x20mm	
ADx1	
ACx1	



Four people are required to assemble and
move this model
Quatre personnes sont nécessaires pour
assembler et déplacer ce modèle

STEP 41:

ÉTAPE 41:

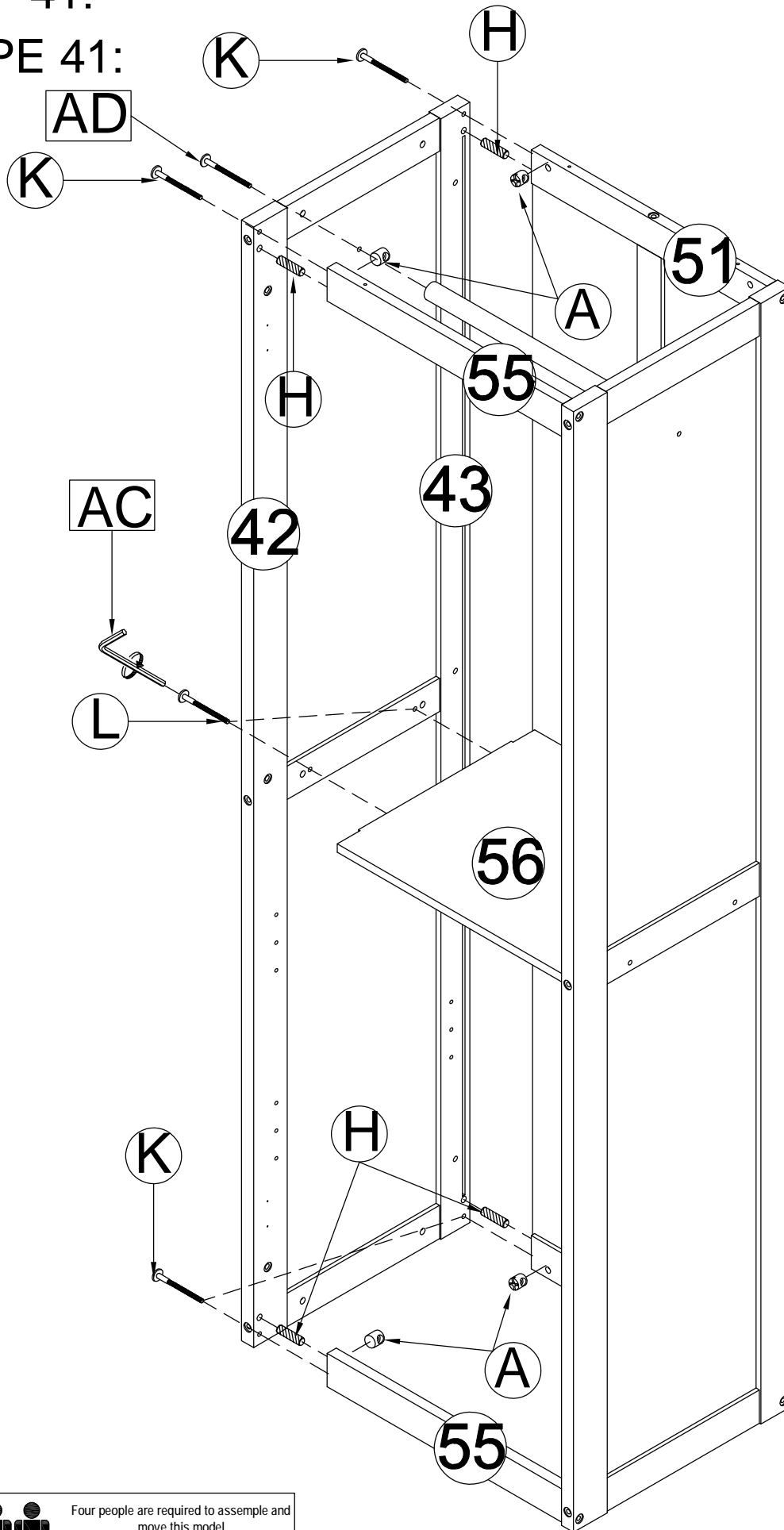

Ø6x13 mm



Ax4

Ø10x40mm

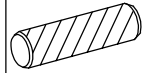

Hx4

Ø6x70mm

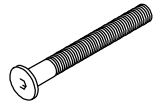

Kx4

Ø6x30mm

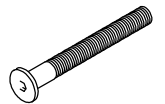

Lx2

Ø6x20mm

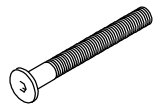

ADx1







ACx1



Four people are required to assemble and move this model
Quatre personnes sont nécessaires pour assembler et déplacer ce modèle

STEP 42:
ÉTAPE 42:

	$\text{Ø}6 \times 40 \text{mm}$ 	$\text{Ø}4 \times 20 \text{mm}$ 	$\text{Ø}6 \times 30 \text{mm}$ 
ACx1	Mx4	Cx2	Lx1

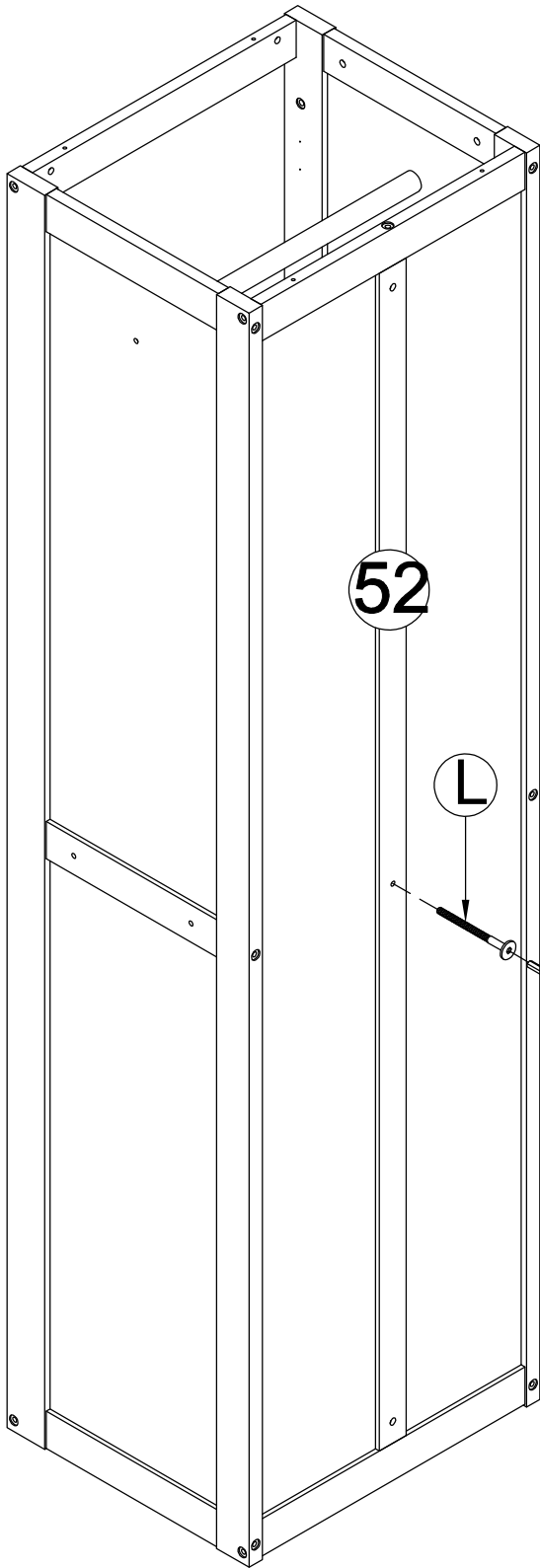

Back View
Vue arrière

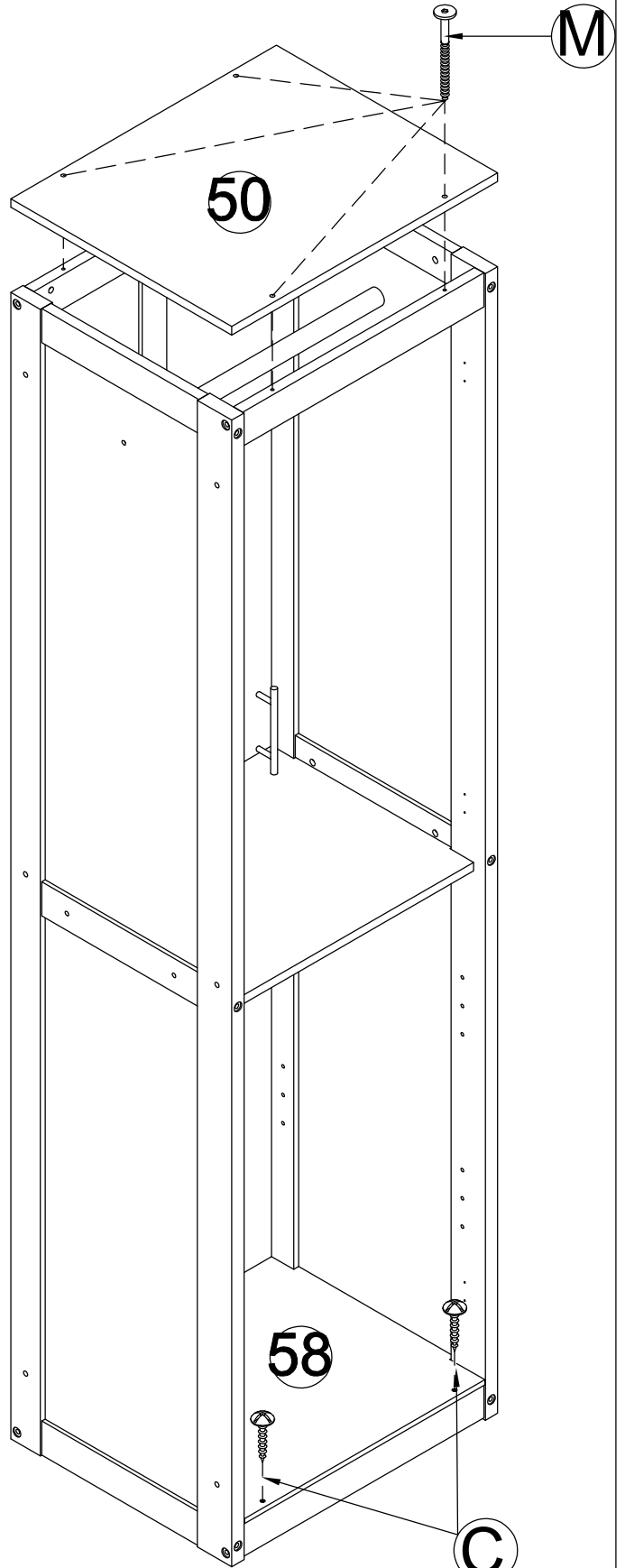

STEP 43:
ÉTAPE 43:

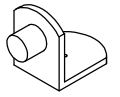

AE8

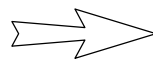
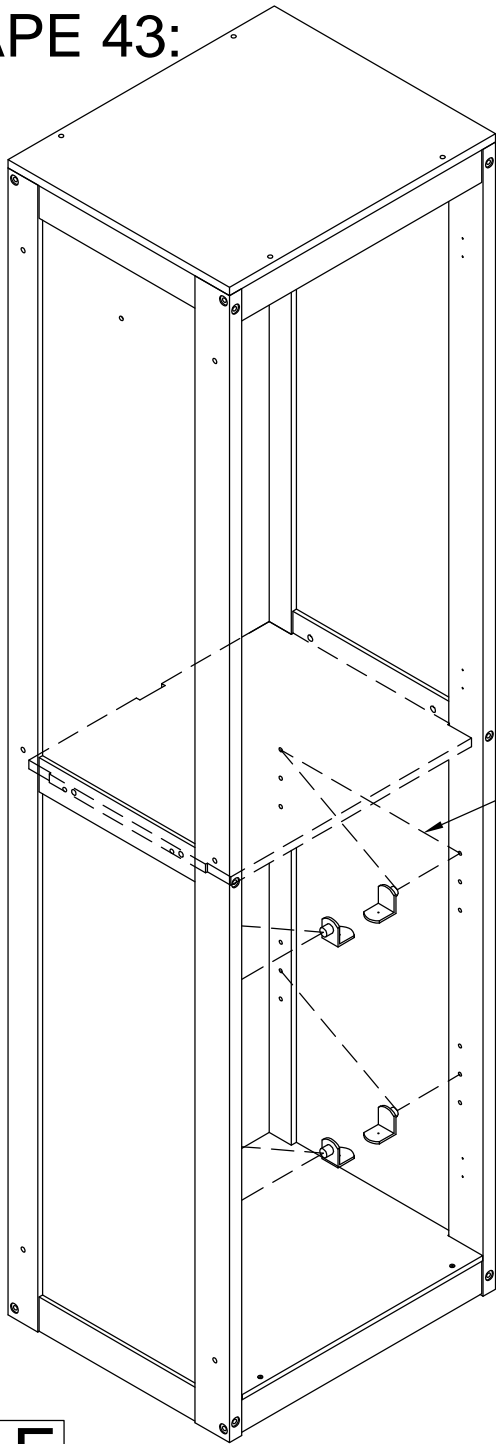

straight/droite

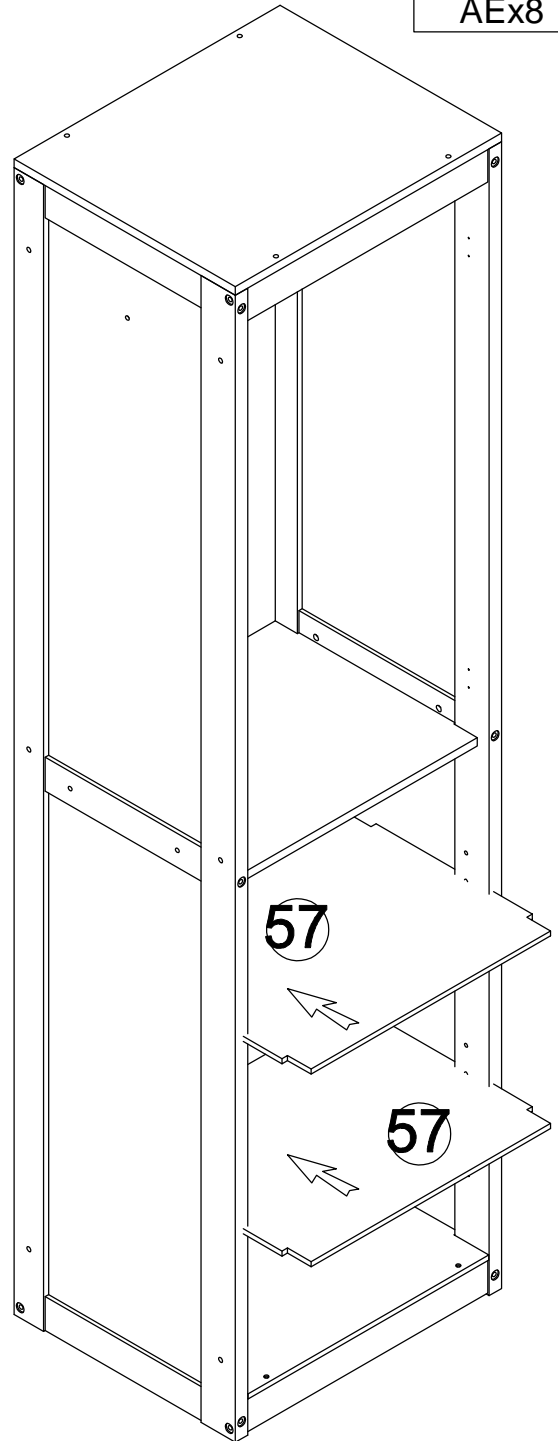

AE

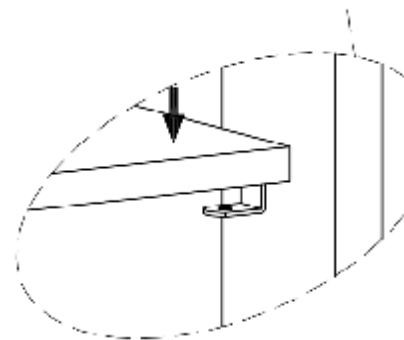
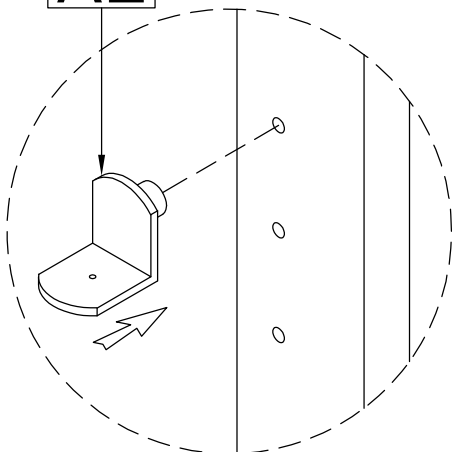

STEP 44:
ÉTAPE 44:

Ø6x70mm



AFx6

M3.5x12

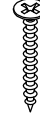

AHx4



AGx2



Rx1

Ø4x15mm

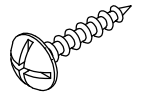

Gx6

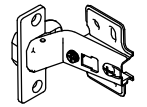

AKx3

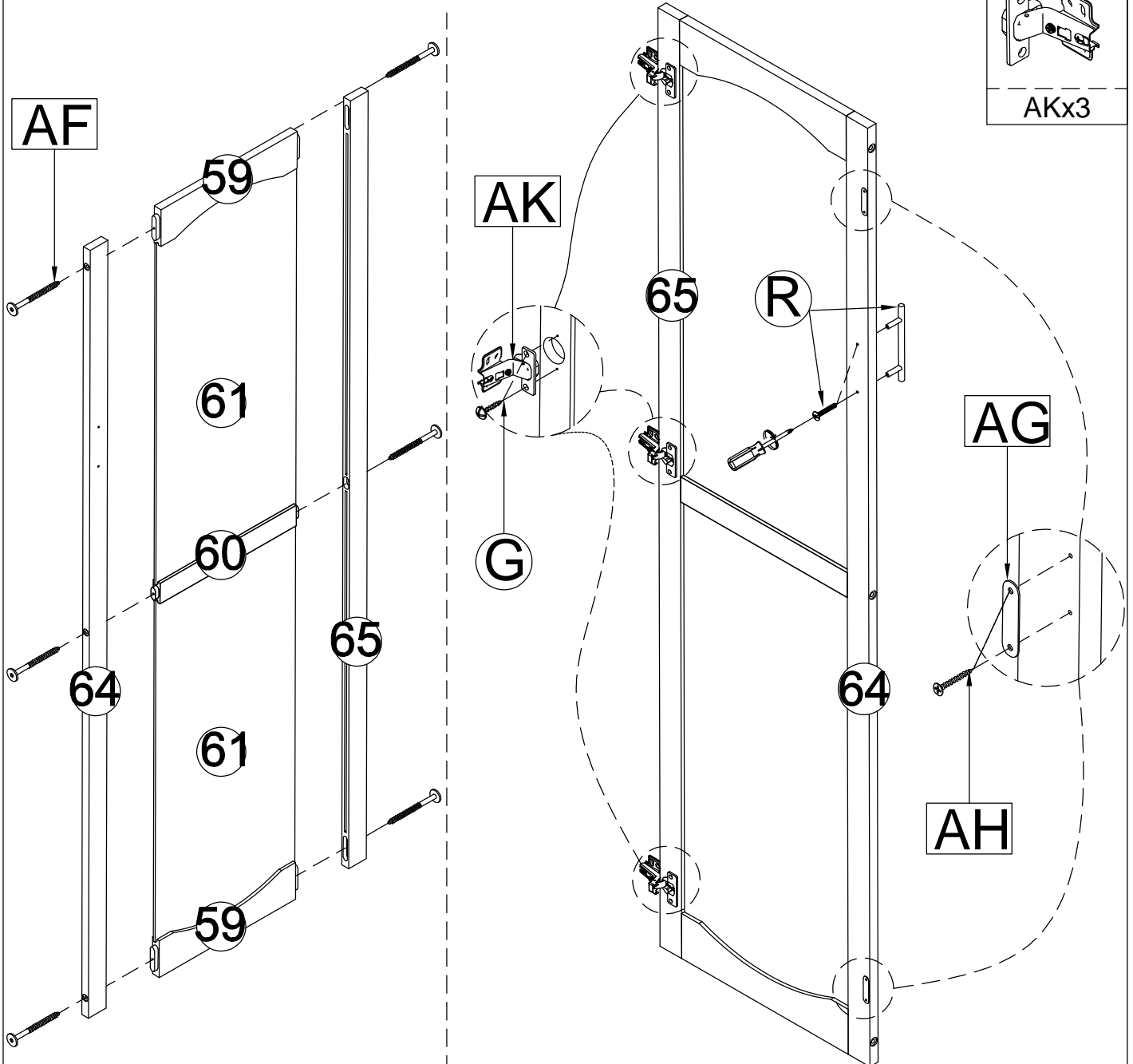

STEP 45:
ÉTAPE 45:

Ø4x15mm

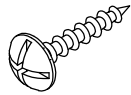

Gx4

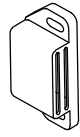

ALx2

STEP 46:
ÉTAPE 46:

Ø4x20mm

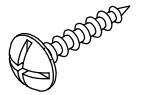

Cx12

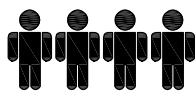
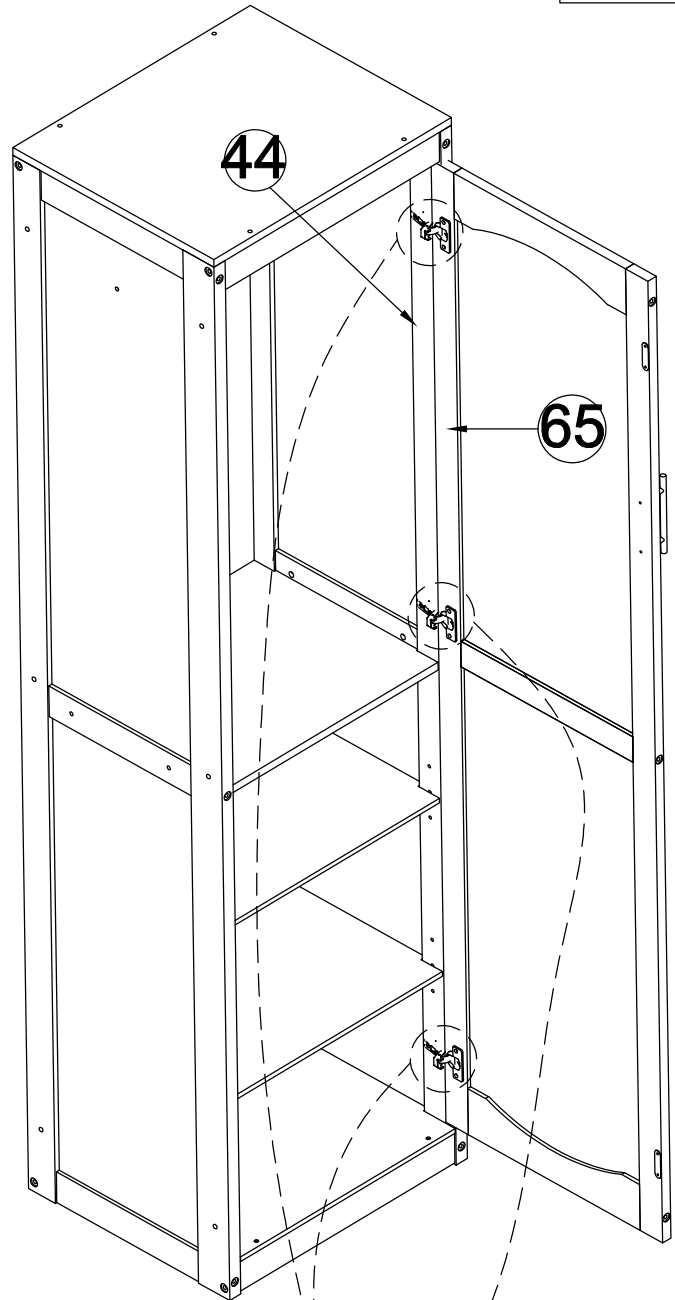
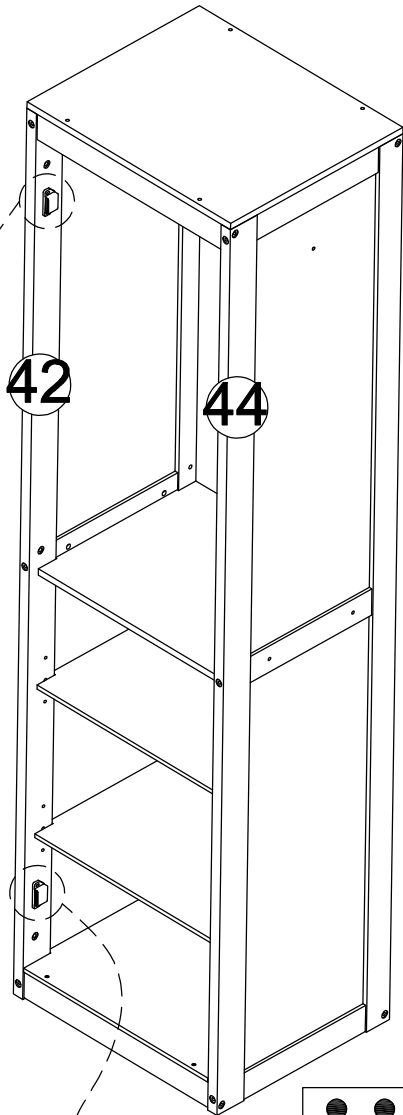

Four people are required to assemble and move this model.
Quatre personnes sont nécessaires pour assembler et déplacer ce modèle.

AL

G

C

STEP 47:
ÉTAPE 47:

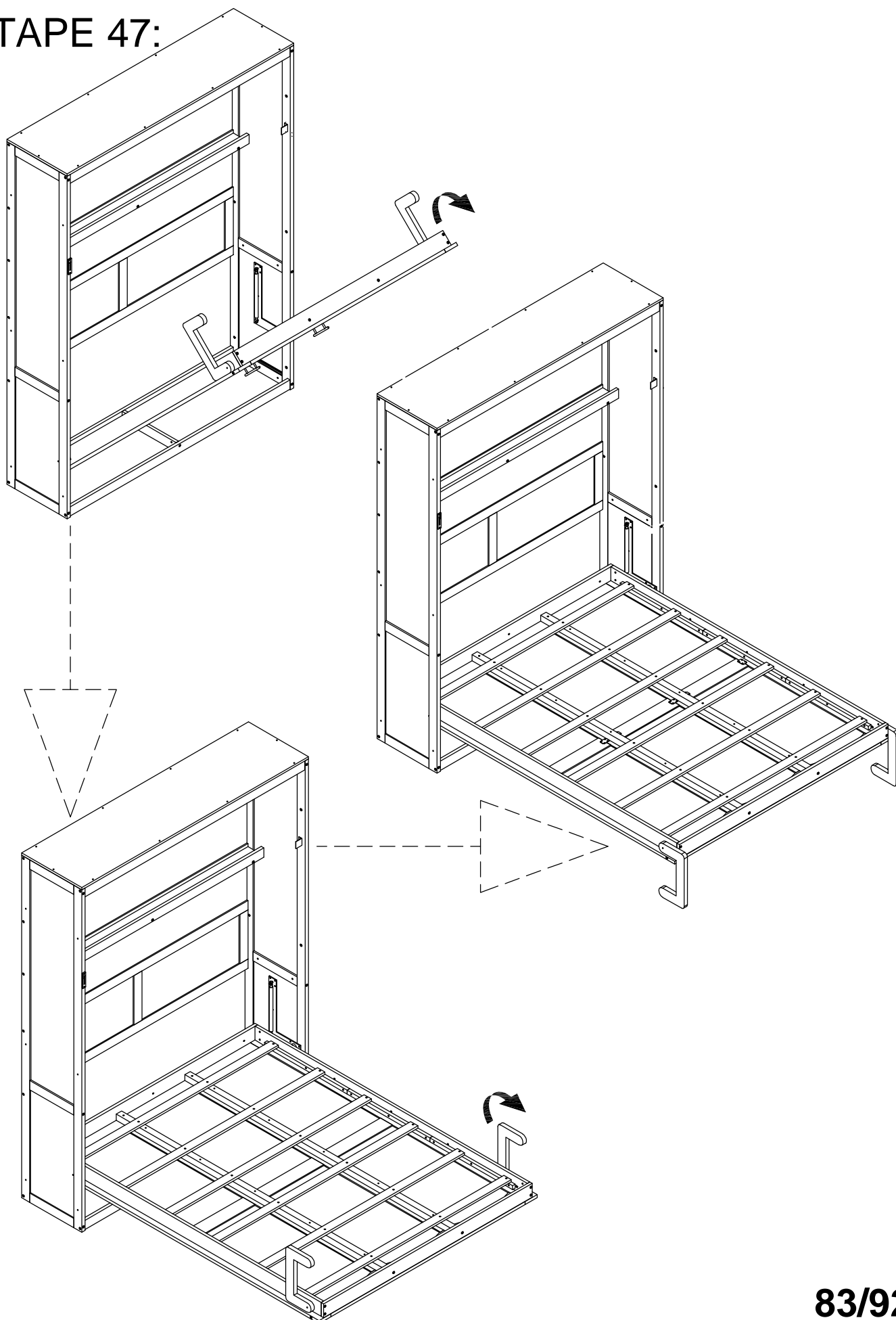

STEP 48:
ÉTAPE 48:

Attach the cabinets to the bed
Fixez les armoires au lit

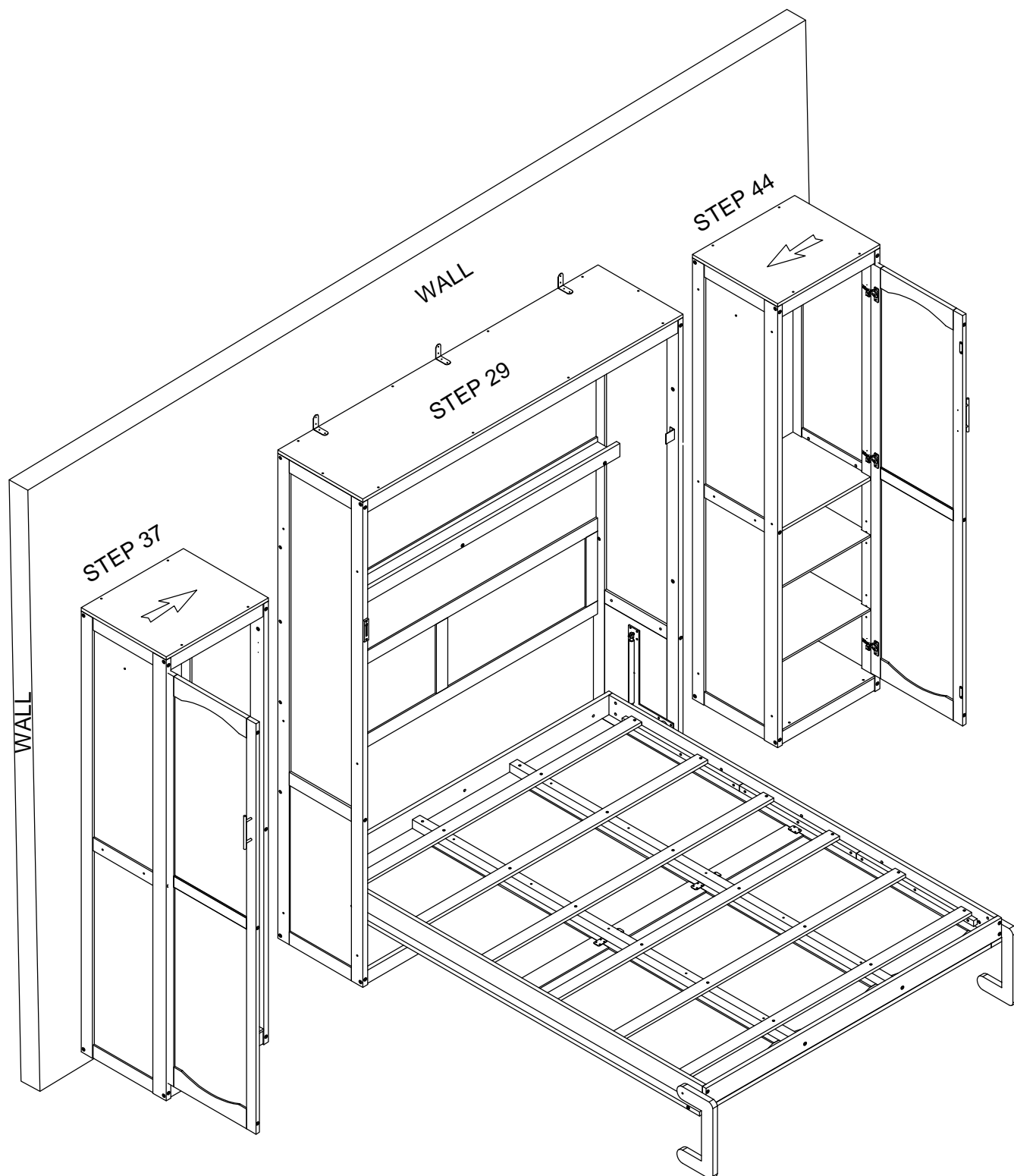

Four people are required to assemble and
move this model
Quatre personnes sont nécessaires pour
assembler et déplacer ce modèle

STEP 49:
ÉTAPE 49:

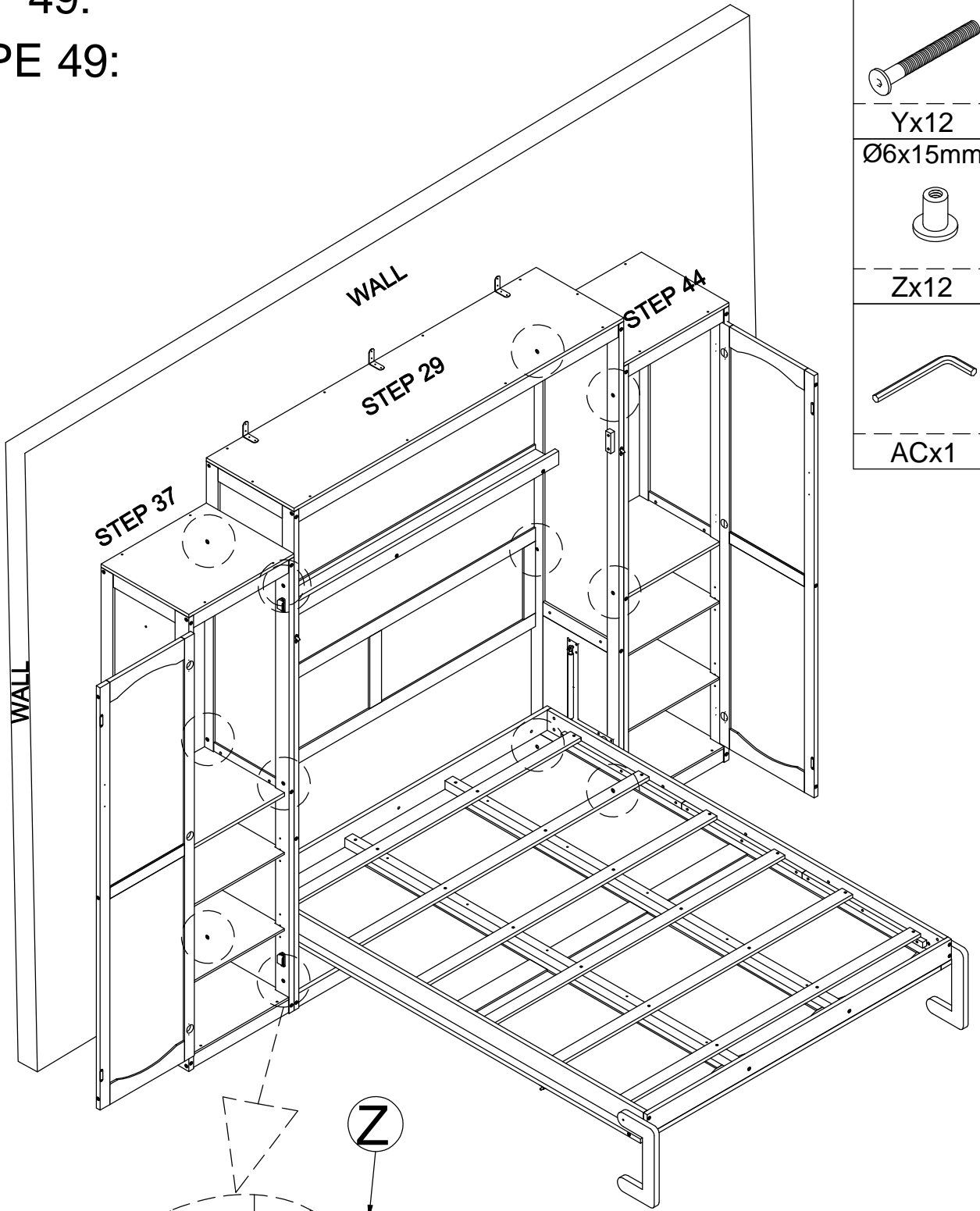

Ø6x40mm

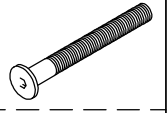

Yx12

Ø6x15mm



Zx12



ACx1

AC

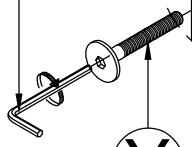

Y

X12

Z



Four people are required to assemble and
move this model
Quatre personnes sont nécessaires pour
assembler et déplacer ce modèle

STEP 50:
ÉTAPE 50:

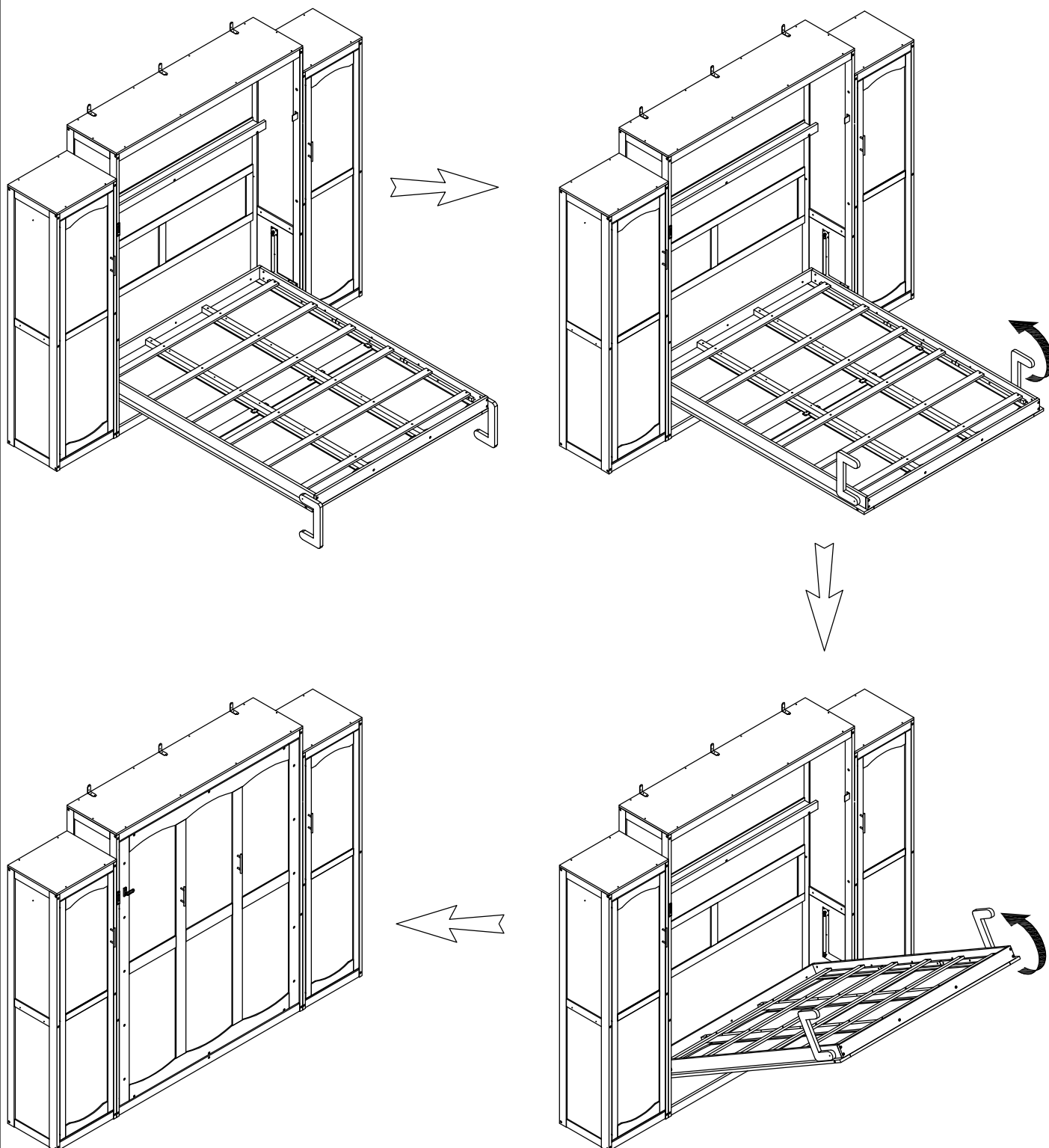

WALL ANCHORING INSTRUCTIONS

INSTRUCTIONS DE FIXATION MURALE

- ① Place part W at the wall-mounted position on top of the cabinet., and mark 4 holes on the 2 corresponding patts.
Placez la pièce W en position de montage mural sur le dessus de l'armoire et marquez 4 trous sur les 2 pattes correspondantes.

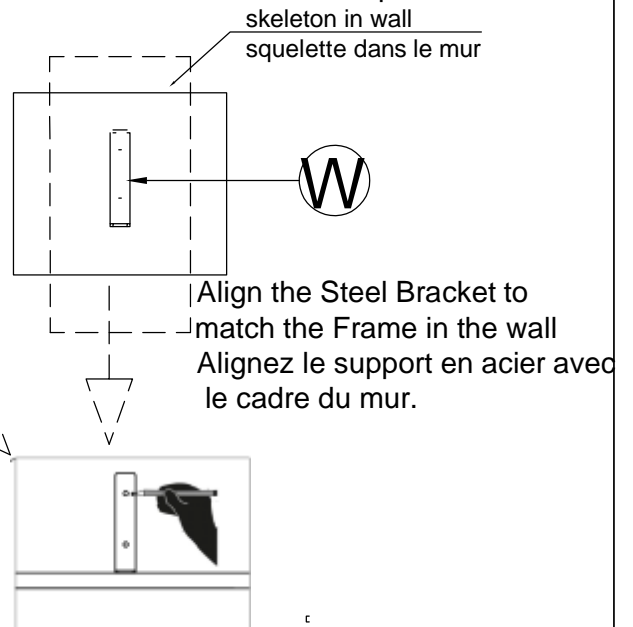
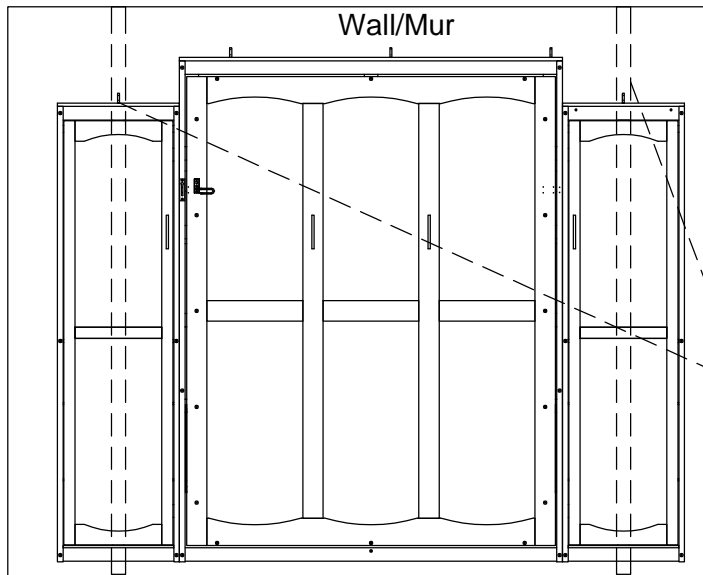

- ② Move the part to another position, then use a wall drill with an 8mm drill bit to drill into the marked positions, ensuring the hole depth exceeds 90mm.
Déplacez la pièce vers une autre position, puis utilisez une perceuse murale avec un foret de 8 mm pour percer les positions marquées, en vous assurant que la profondeur du trou dépasse 90 mm.

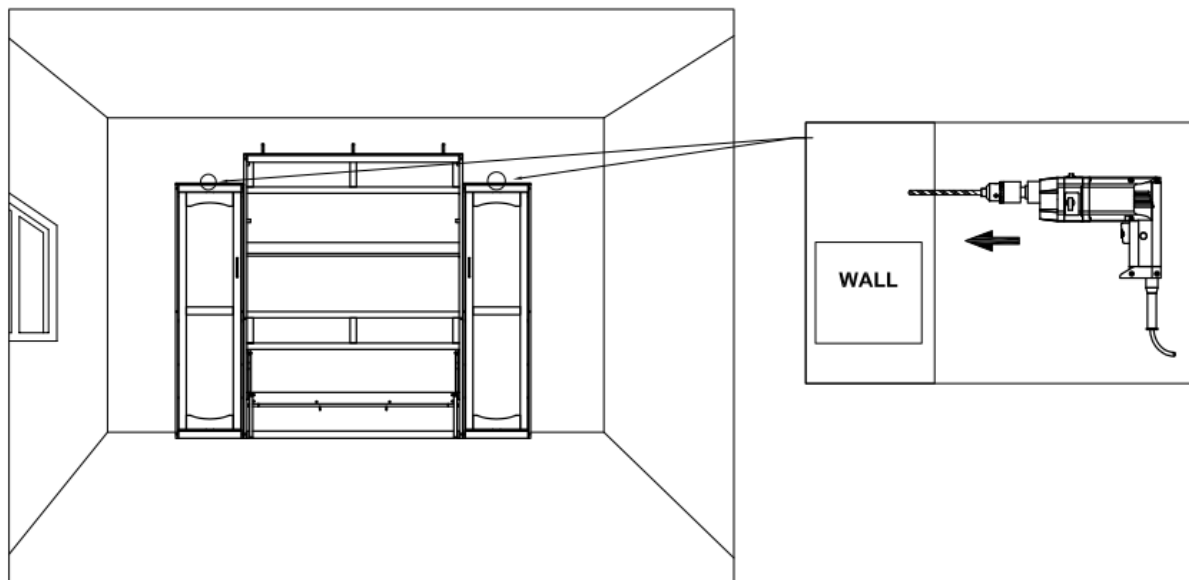

STEP 51:

*-Position on the wall to align the plastic stopper (AA) with the hole positions on the part (W) at the bed's location

ÉTAPE 51:

*-Positionner sur le mur pour aligner le bouchon en plastique (AA) avec les positions des trous sur la pièce (W) à l'emplacement du lit

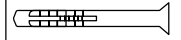

AAx4

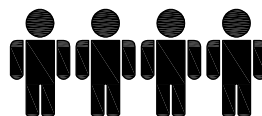
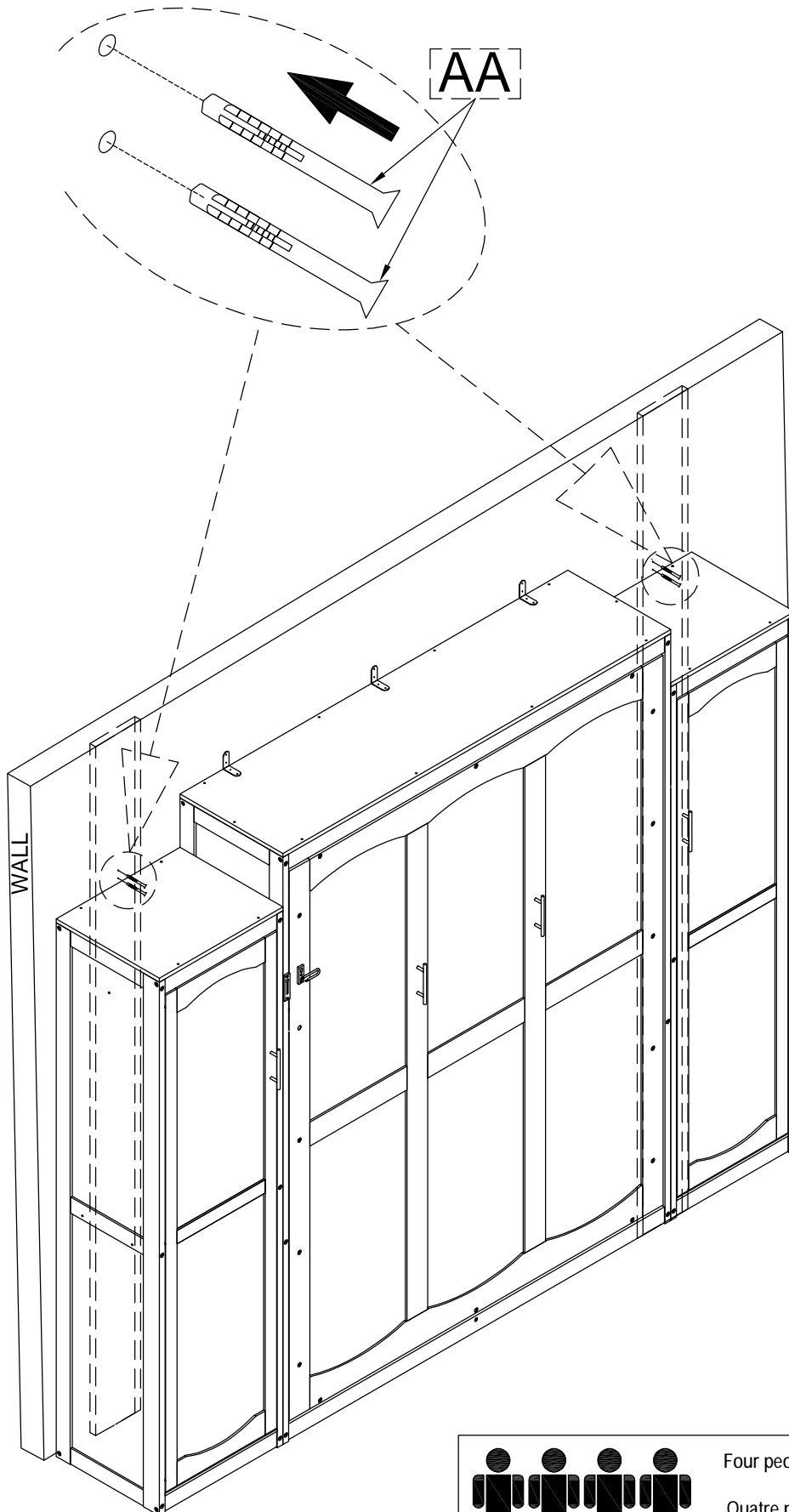

Four people are required to assemble and move this model
Quatre personnes sont nécessaires pour assembler et déplacer ce modèle

STEP 52:
ÉTAPE 52:

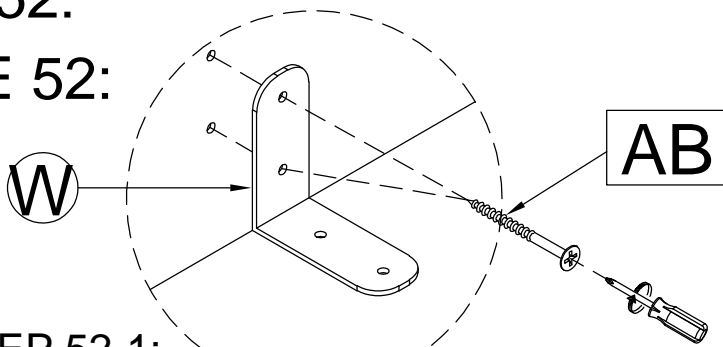

STEP 52-1:
ÉTAPE 52-1:

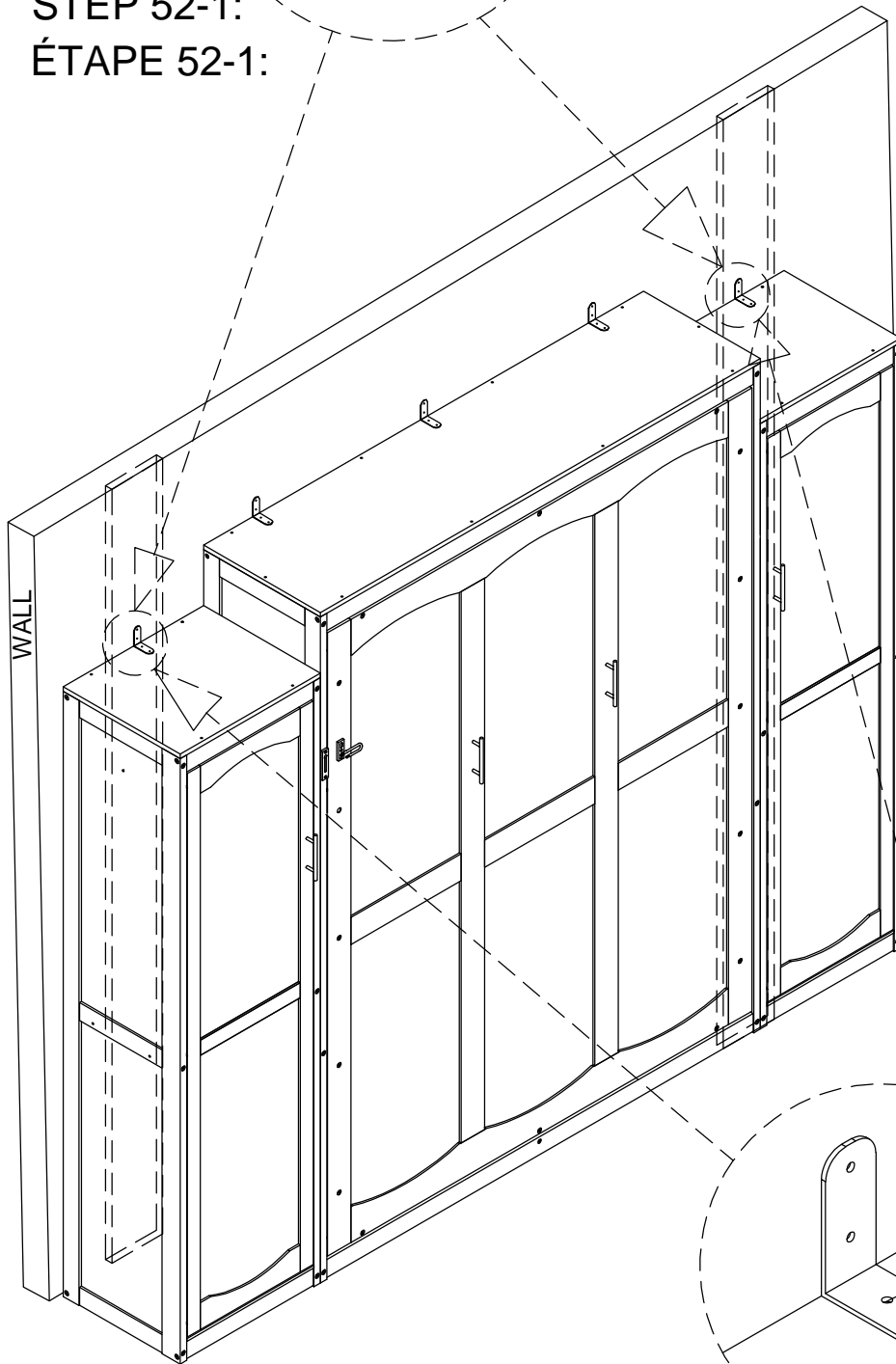

Ø4x15mm

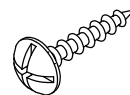

Gx4

M5x80mm

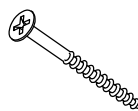

ABx4

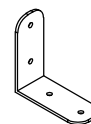

Wx2

G

STEP 52-2:
ÉTAPE 52-1:



Four people are required to assemble and move this model
Quatre personnes sont nécessaires pour assembler et déplacer ce modèle

OPTION 1

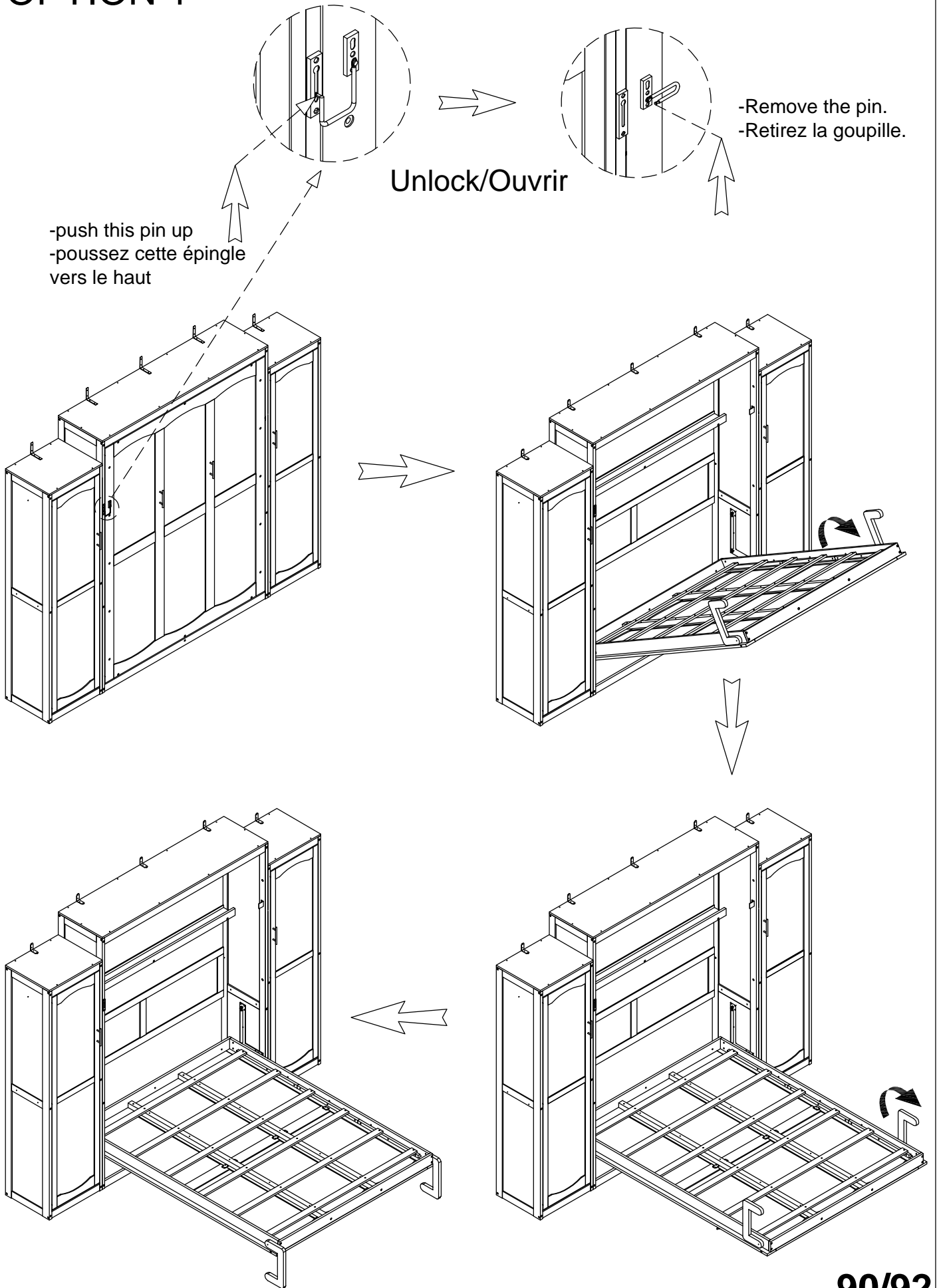

OPTION 2

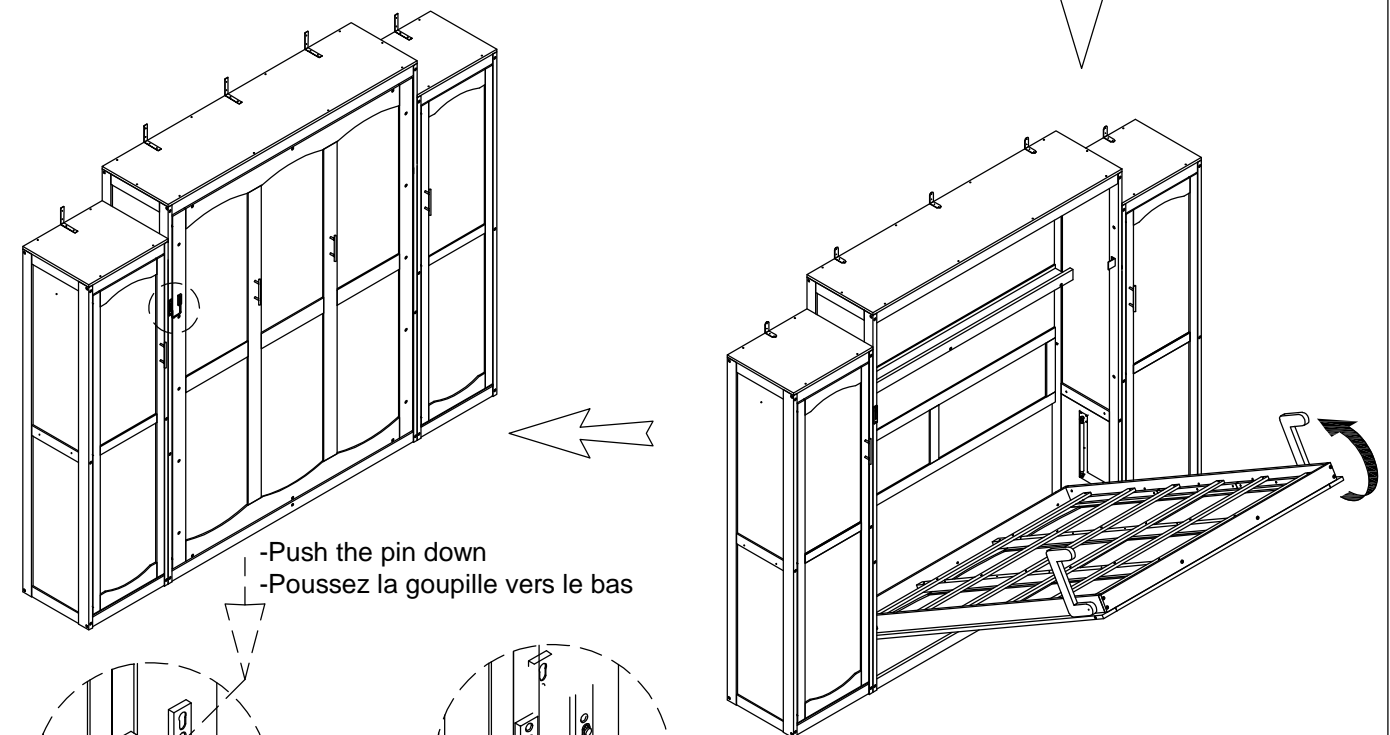
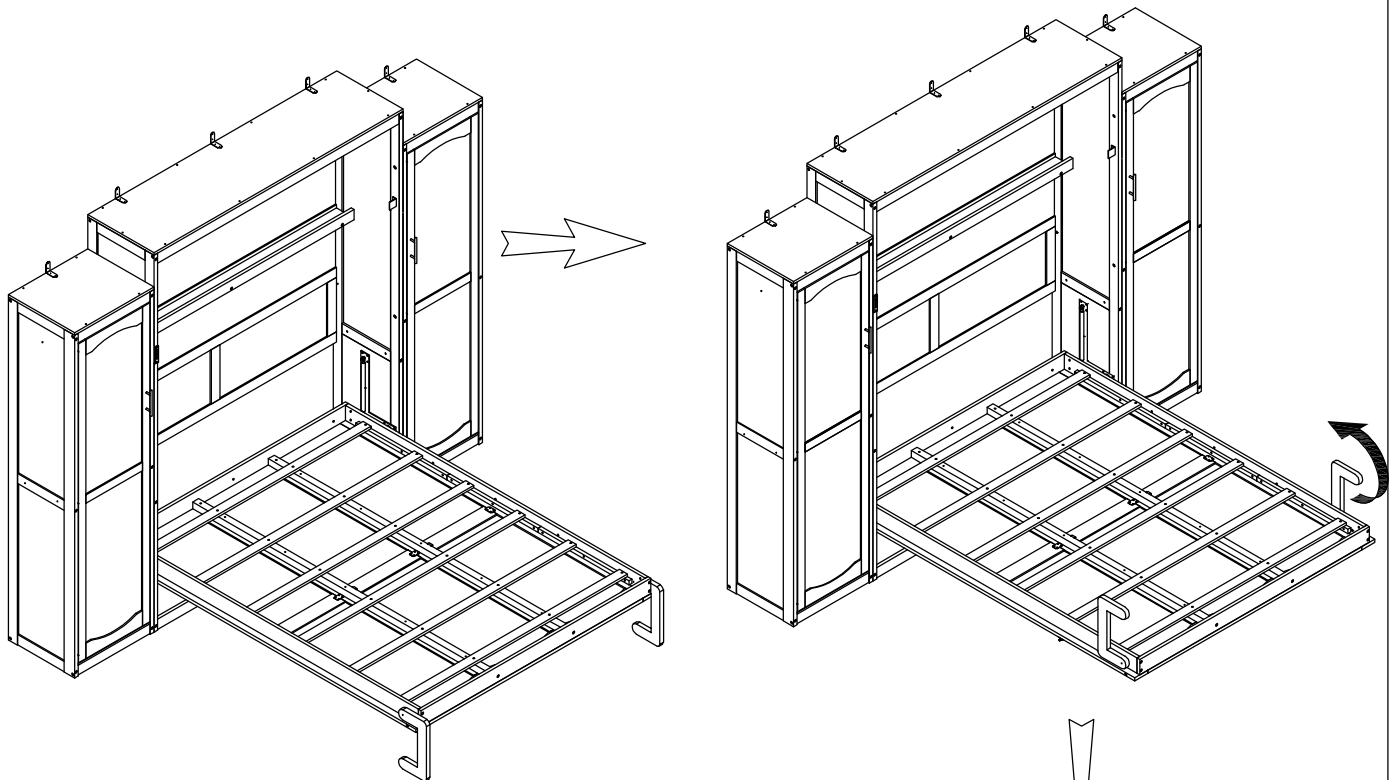

-Push the pin down
-Poussez la goupille vers le bas

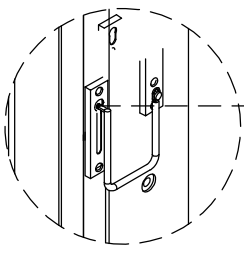
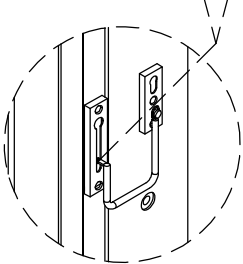

-Push the pin into the groove
-Enfoncer la goupille dans la rainure

Lock/Verrouillage

CONGRATULATION. YOU HAVE COMPLETED THE BED
FÉLICITATION. VOUS AVEZ TERMINÉ LE LIT

