

INSTALLATION GUIDE

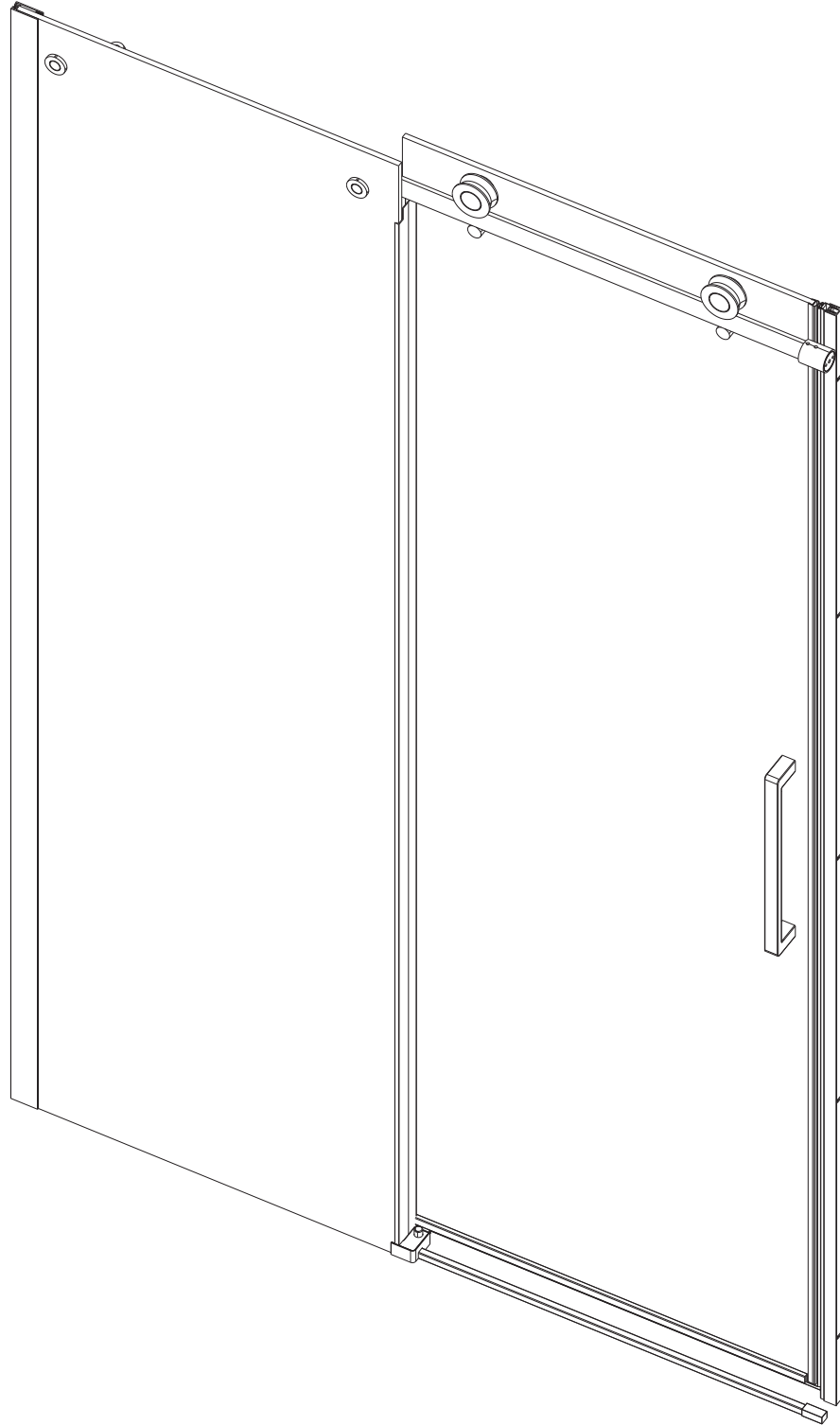

Sliding Frameless Shower Door
Shower Door (doors only) 25/64" glass (10mm)

CAUTION: To reduce the risk of breakage, keep the corner protectors on glass while installing.

Keep corner protectors for use in case future adjustments are needed. Consult your local plumbing codes before installation.

Recommended clearance heights for installation: 78 inches (198 cm)

Recommended width for installation:

60-inch enclosure:

56-60 inches (142.2 - 152.4 cm)

48-inch enclosure:

44-48 inches (111.8 - 121.9 cm)

REQUIRED TOOLS

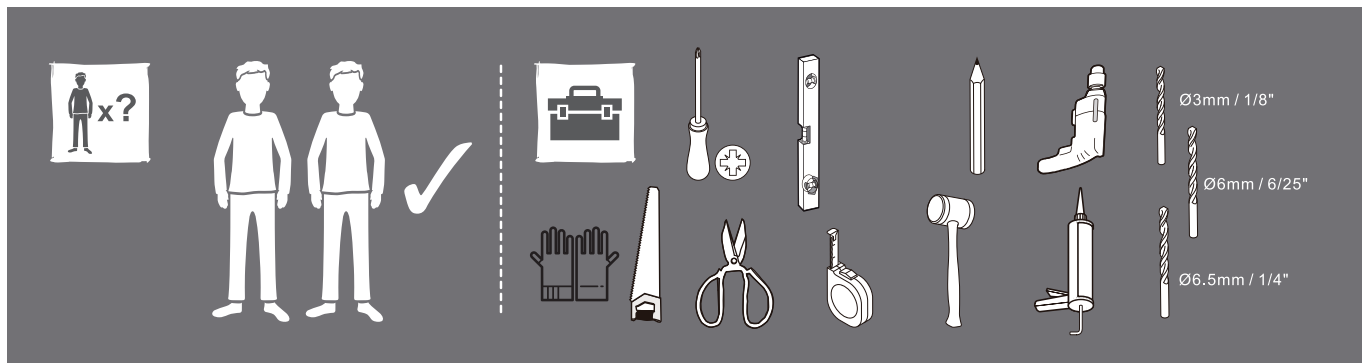

IMPORTANT: To install your shower door unit, you must:

- (1) Completely read all instructions, warnings, cautions, and care and maintenance information;
- (2) Purchase the correct water supply components.

CAUTION: Failure to install this product according to installation instructions may result in personal injury, property damage, or product failure, and may void the warranty.

CAUTION: When cutting or drilling metal components or when handling glass, to reduce the risk of personal injury, protective eye-wear, gloves, and closed-toe shoes are required.

BEFORE YOU START

CAUTION: Risk of injury or product damage. During installation, tempered glass should not come in direct contact with metal parts or hard surfaces (such as tile/concrete flooring), or it may shatter. Gaskets and bushings must always be used between glass and metal.

CAUTION: Risk of injury or product damage. Do not touch the edges of tempered glass with tools. Do not attempt to cut tempered glass, or it will shatter.

CAUTION: Once installed, glass panels must be clear of all shower environment obstructions to avoid the risk of personal injury, property damage, or product failure. Ensure appropriate clearances exist before beginning the installation process.

CAUTION: Door installation requires at least two people.

NOTICE: Tempered safety glass is stronger than normal glass, but it is not unbreakable. A scratch to the glass or contact with a hard surface (such as a screw head or a concrete telephone floor) can cause it to break or weaken. This could happen immediately or even at a later time cause the glass panes to shatter into many small pieces without apparent cause. When it does break, it loudly explodes into thousands of smaller pieces (the smaller pieces reduce the risk of personal injury).

NOTE:

- Shower opening dimensions:
 - 48" Shower: 44" minimum-48" maximum
 - 60" Shower: 56" minimum-60" maximum
- Walls must be within 3/8" of plumb (vertical). Dimensions at the top and bottom of the shower should be within 3/8" of each other.
- Cover the tub or shower drain with a rag or tape to avoid loss of small parts.
- Limited 5-Year Warranty; conditions may apply

CARE AND CLEANING

For regular cleaning, use only mild detergents or warm, soapy water. Use only a non-abrasive cloth or sponge. Always rinse surfaces after cleaning. Before cleaning this product with cleaning products, test a small, inconspicuous area.

CAUTION: The manufacturer does not recommend the use of cleaning products that contain any of the following chemicals. Use of products containing these chemicals can cause the products to discolor and will void the warranty.

*Naphtha

*Hydrogen Peroxide Solution (common household peroxide)

*Toluene

*Ethyl Acetate

*Lye (common in drain cleaner)

*Acetone

For optimal maintenance, it is recommended that the glass panels be squeegeed on a regular basis after the shower is used. For further inquiries, contact customer service.

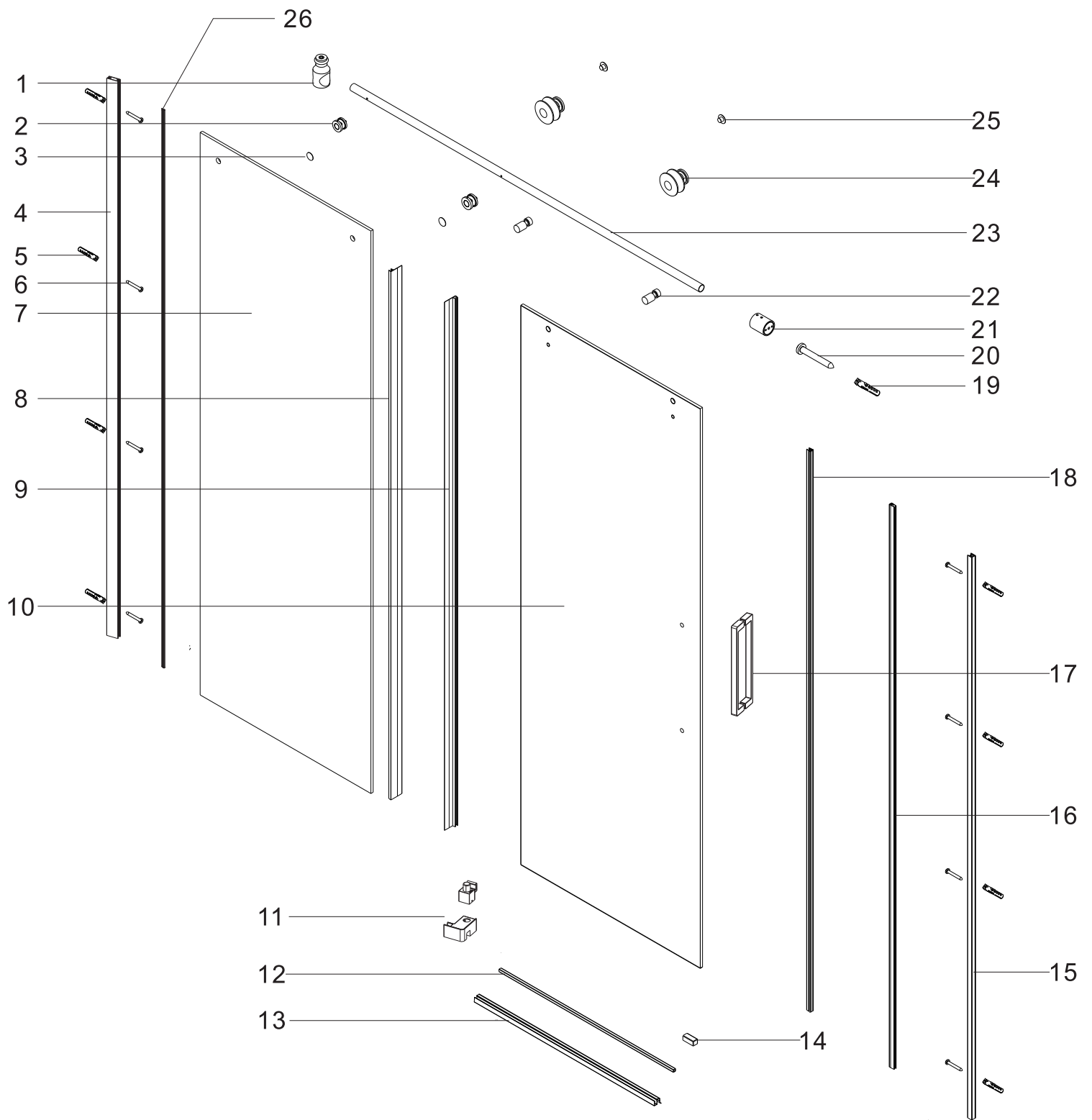

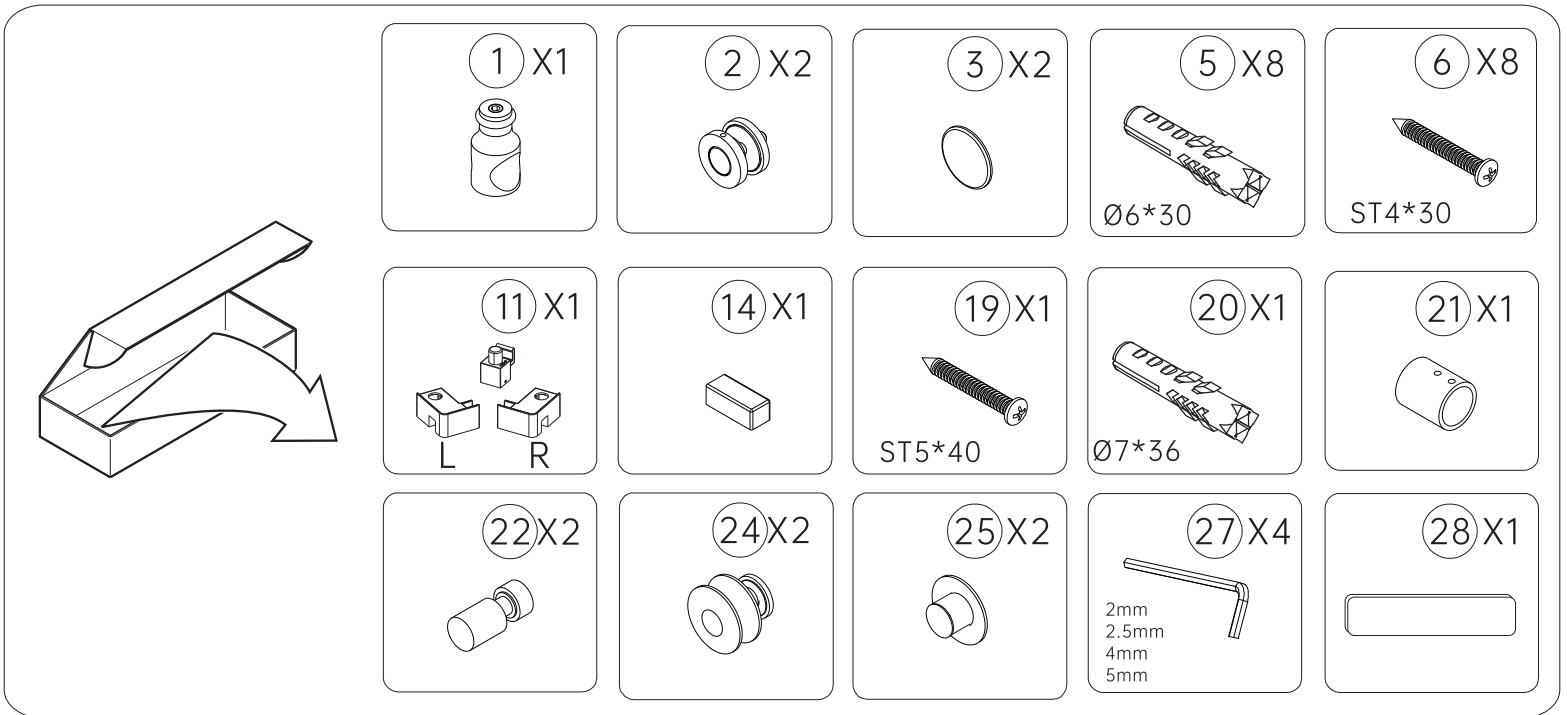
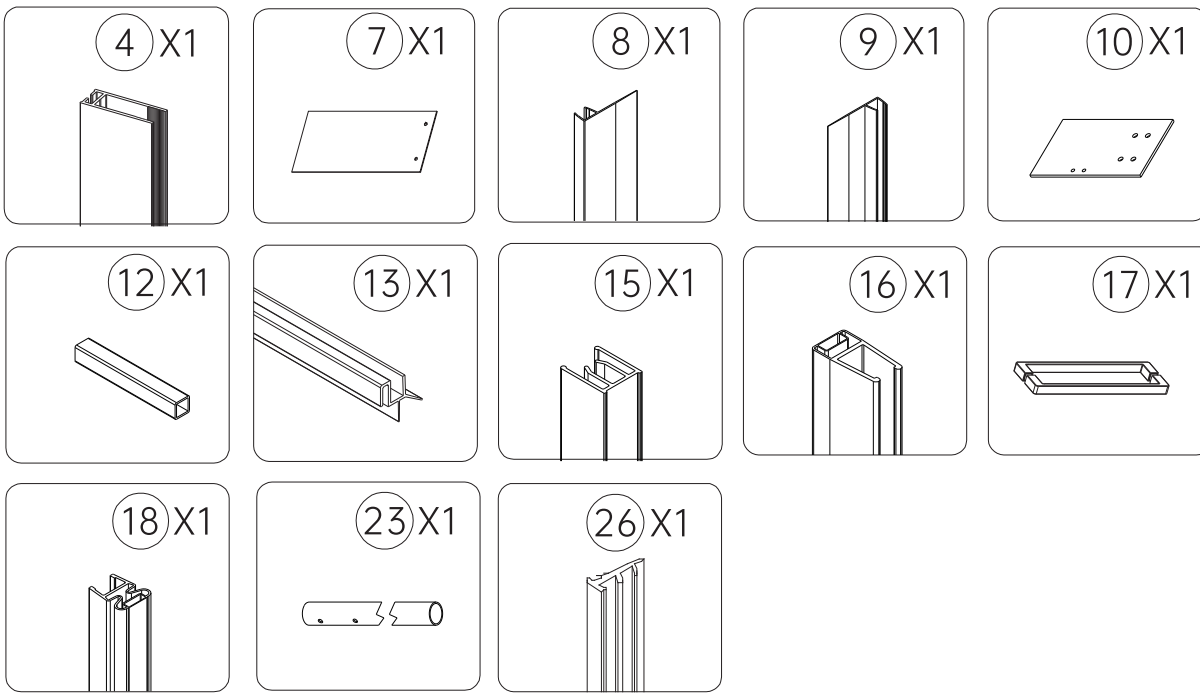

1 Door Stopper

2 Fixed Glass Bolt Assembly

3 Cover A

4 Vertical Channel

5 Expansion Bolt 6*30mm

6 Screw ST4*30 mm

7 Fixed Glass

8 Door Seal A

9 Door Seal B

10 Sliding Door

11 Door Threshold End Cap Set

12 Door Threshold Bar

13 Bottom Door Seal

14 Seal Caps

15 Sliding Wall Post

16 Post

17 Handle

18 Magnetic Seal

19 Screw ST5*40 mm

20 Expansion Bolt 7*36mm

21 Rail End

22 Anti-Drop Nail

23 Top Rail

24 Roller Assembly

25 Cover B

26 Door Seal C

27 Hexagonal Wrench

28 Auxiliary Mounting Plate

01

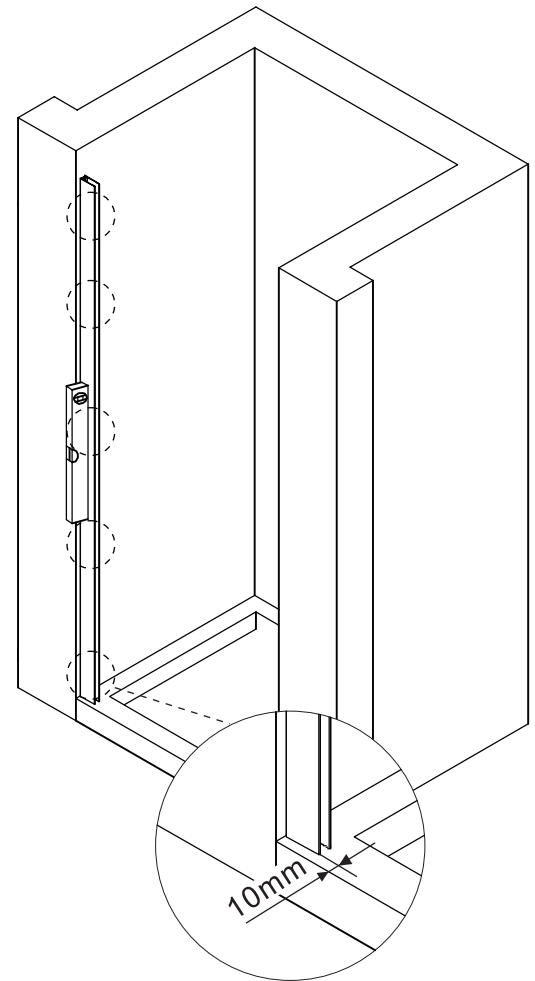
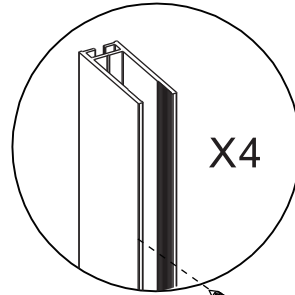
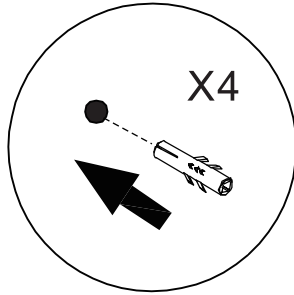
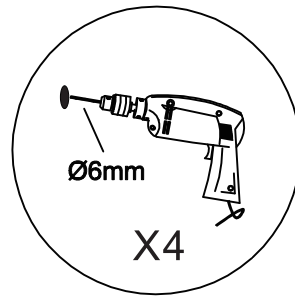
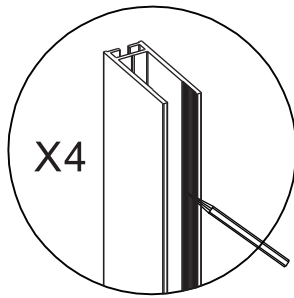
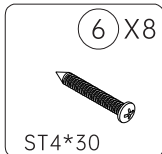
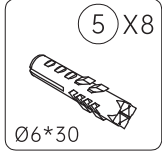
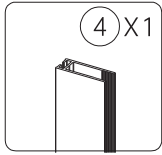

A.Before installation, ensure that the distance between the Vertical Channel(4) and the bottom edge is 10mm, and use a level ruler to measure the level.

B.After confirming the level, use a pencil to mark the hole position in the groove of the Vertical Channel(4).

C.Remove the Vertical Channel(4) and use a 6mm drill bit to drill.

D.After drilling, place the Expansion Bolt 6*30MM(5) into the hole.

E.Then align the Vertical Channel(4) with the drilled hole and use an electric drill or screwdriver to screw the Screw ST4*30 MM(6) into the hole and tighten it clockwise.

NOTE:

1.Before installation, ensure that the distance between the vertical Channel(4) and the bottom edge is 10mm.

2.When drilling, make sure to wear a mask, work gloves and goggles.

3.If you encounter any resistance when inserting the Expansion Bolt 6*30MM(5) into the hole, you can use a rubber hammer to knock it.

02

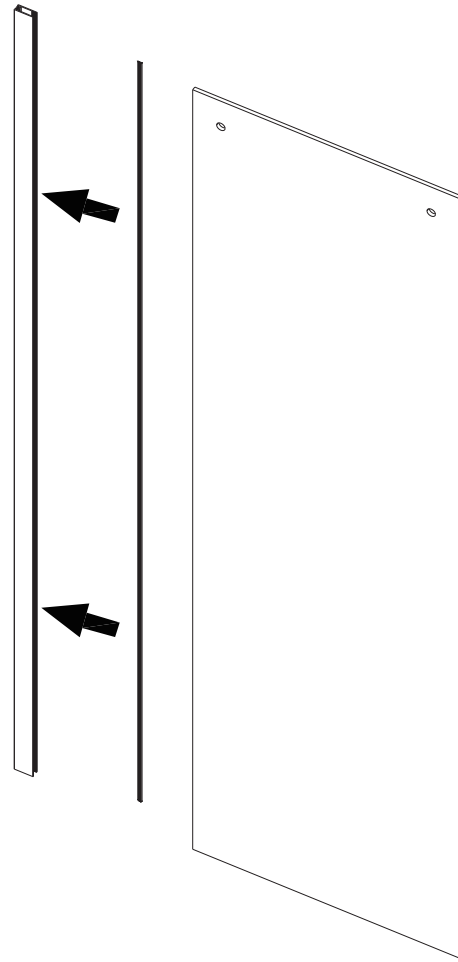
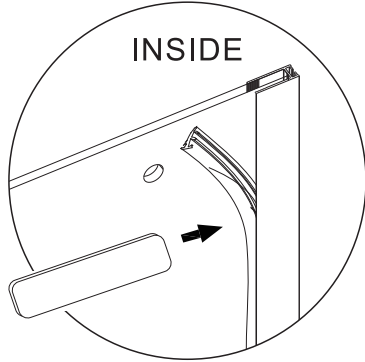
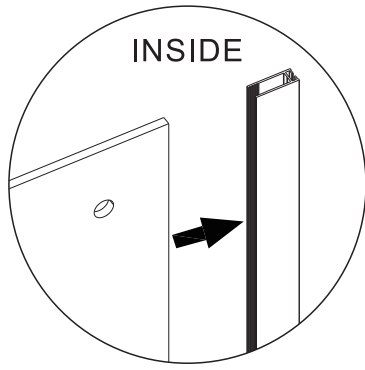
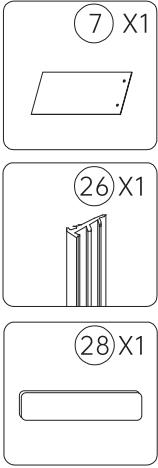

A. After completing the installation of step 1, insert the fixed glass(7) into the groove of the vertical channel(4) as shown in the installation picture.

B. Then insert the door seal C(26) from the gap inside the bathroom as shown in the picture. You need to use the exclusive tool "auxiliary mounting plate(28)" in our accessories to assist in the operation.

NOTE:

1. When installing the fixed glass(7), you need to ensure that two people are working on it.
2. You need to confirm again and again that the door seal C(26) is inserted from the inside of the bathroom. If it is inserted from the outside, it will affect the overall waterproofing.
3. If you do not find the auxiliary mounting plate(28) when inserting the door seal C(26), you can contact us to obtain the accessories or use other tools for assistance.

03

(23)X1

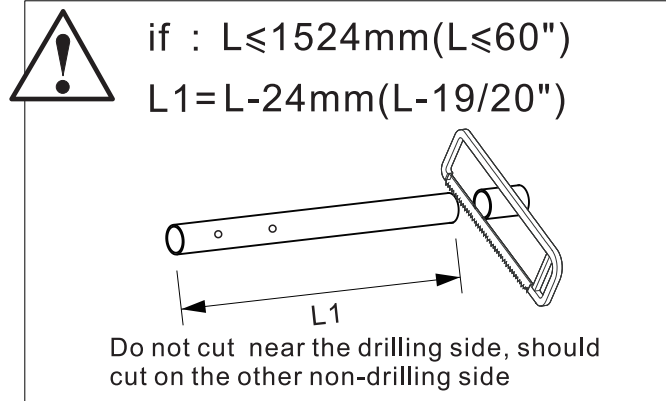
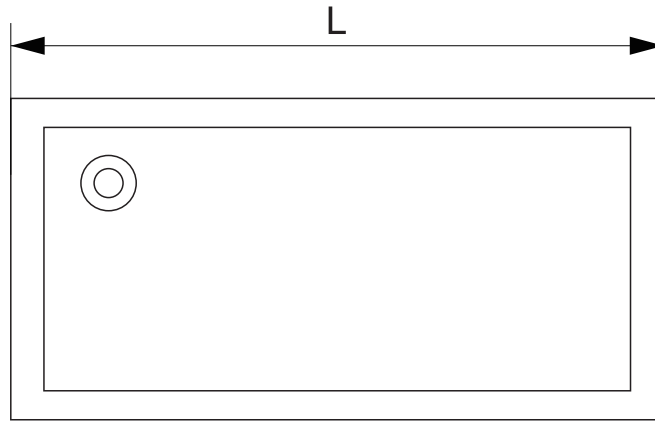
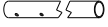

This step requires confirming the length of the top rail(23):

A.First, measure the distance of the installation location.As shown in the figure,"L"refers to the distance of the shower door installati on. According to the formula in the figure, we need to confirm that t he distance is less than or equal to 1524mm.

B.After measuring the size of L, measure the top rail(23) according to the formula in the figure.

NOTE:

- 1.When measuring, you need to confirm the size of L again and again to avoid inaccurate cutting distance of the top rail (23).
- 2.Do not cut near the drilling side, should cut on the other non-drilling side.
3. Make sure to wear a mask, goggles and work gloves when cutting.

04

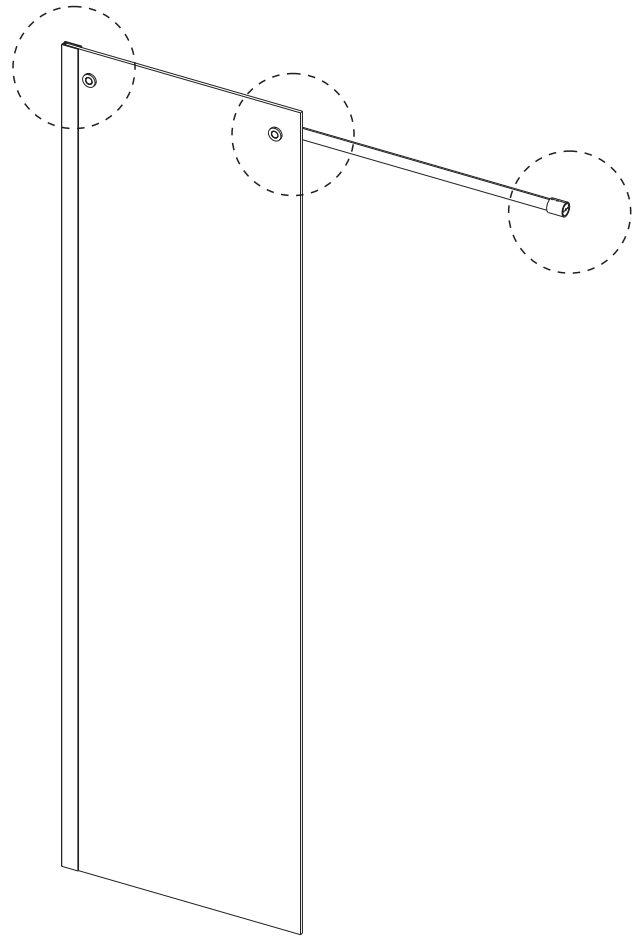
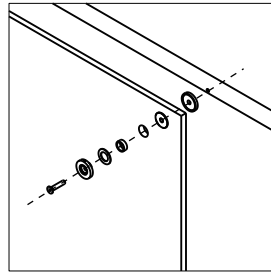
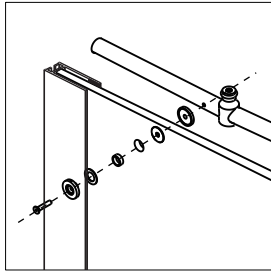
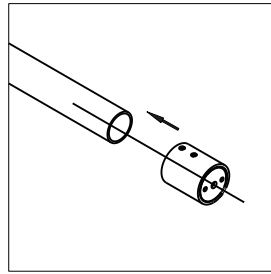
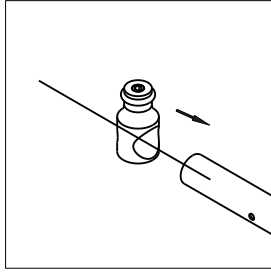
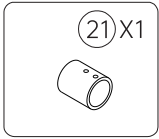
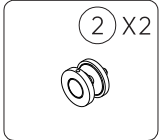

A. After completing step 3, slide the door stopper (1) along the hole in the top rail (23) as shown in the picture.

B. Then slide the rail end (21) in from the other side.

C. Align the top rail (23) with the hole in the fixed glass (7).

After disassembling the fixed glass bolt assembly (2), tighten the bolts in the order shown in the picture.

NOTE:

1. Each operation in this step must be performed by two people.

2. This step involves a large number of metal parts. During installation, be sure to avoid metal parts hitting the glass door.

05

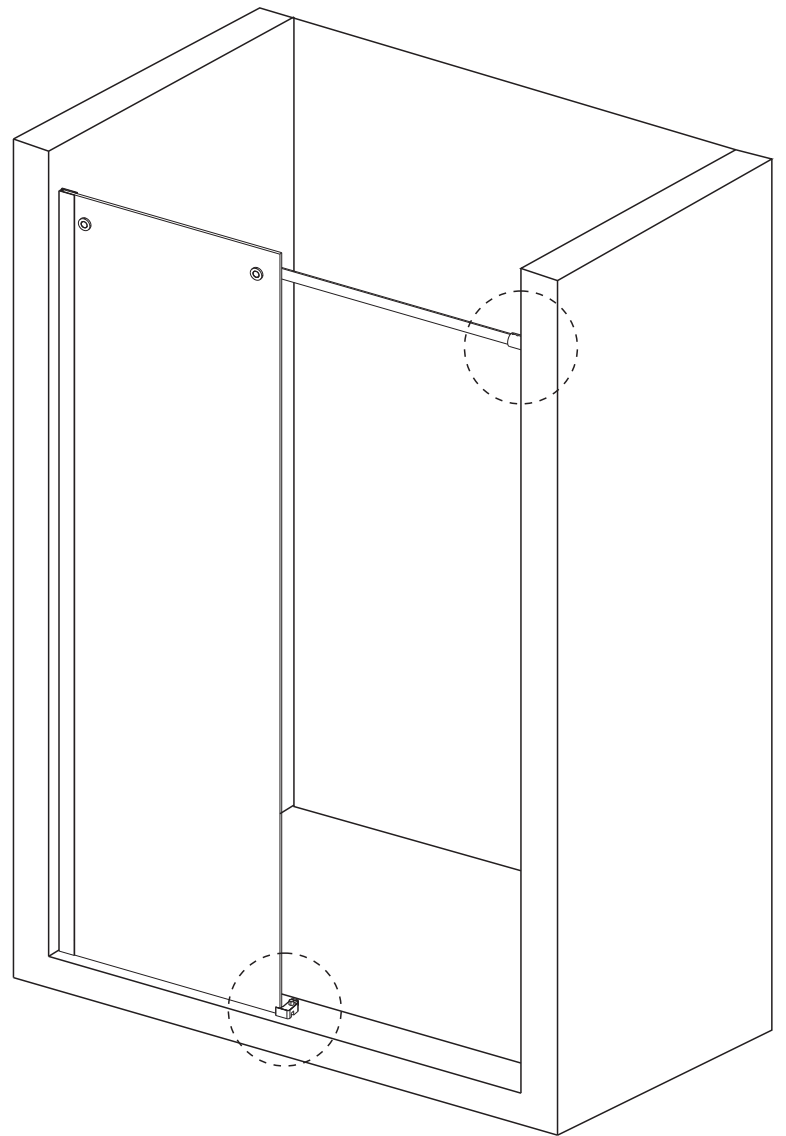
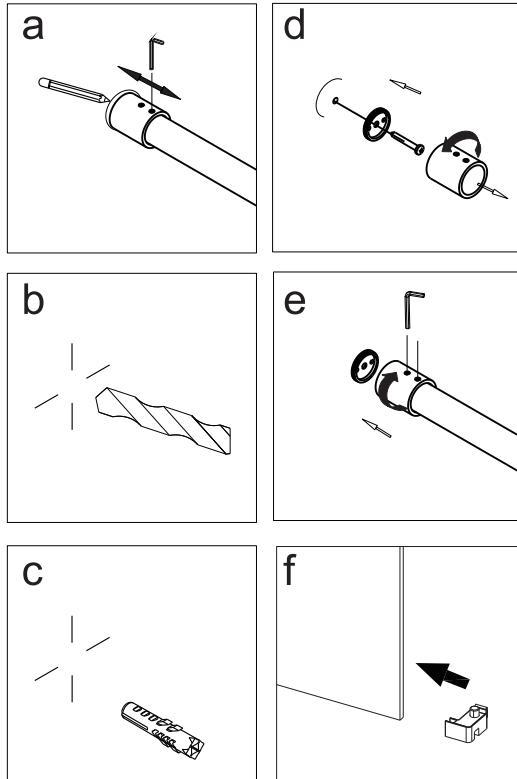
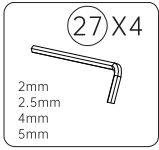
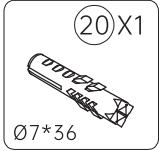
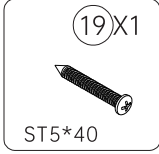
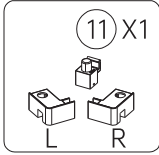

- A. After completing step 4, we need to confirm the punching point on the other side. Use a pencil to draw a circle around the rail end (21) to mark the punching point. The punching point is the center of the circle.
- B. After marking the center of the circle with a pencil, use an electric drill to drill the hole and then insert the expansion bolt (20).
- C. After completing the drilling, use an electric drill and screw (19) to tighten the fixing point on one side of the rail end (21) to the wall.
- D. After fixing, align the rail end (21) and then turn the knob clockwise until the entire top rail (23) is stable.
- E. Finally, fix the door threshold end cap set (11) to the bottom edge of the fixed glass (7) as shown in the picture.

NOTE:

1. When performing the drilling operation, make sure to wear a mask, work gloves and goggles.
2. If you encounter resistance when inserting the expansion bolt (20), you can use a rubber hammer to assist.
3. If the fixed glass (7) is installed on the left side, use the left door threshold end cap set (11). Otherwise, use the right door threshold end cap set (11).

06

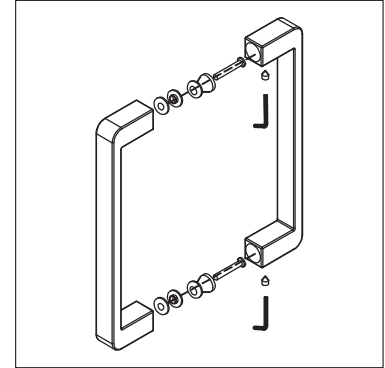
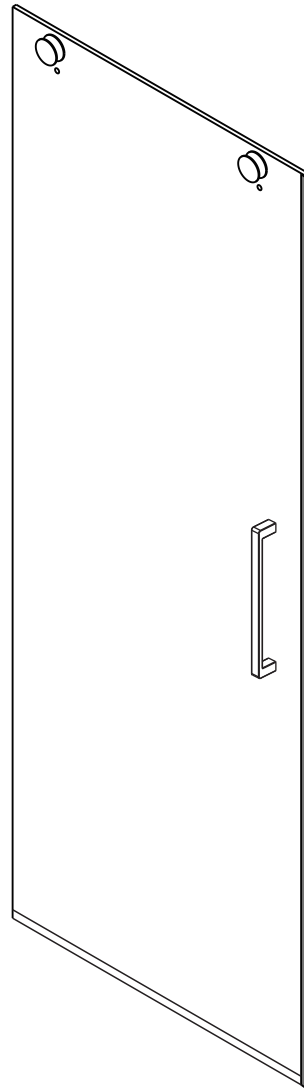
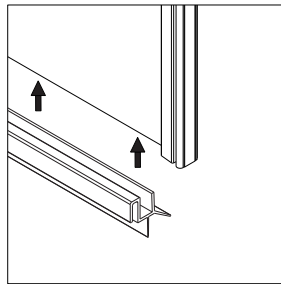
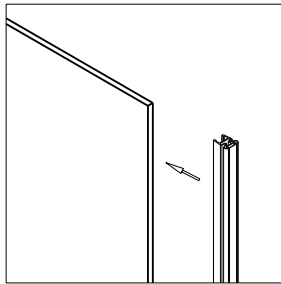
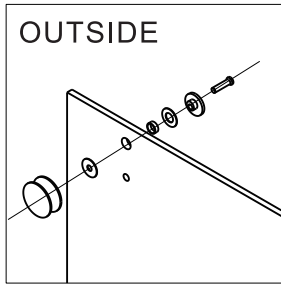
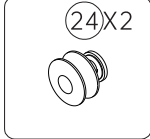
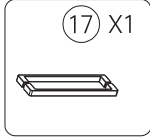
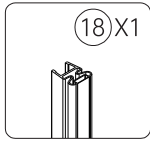
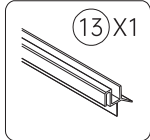
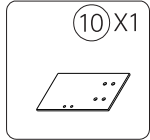

A. First, install the roller assembly (24) on the sliding door (10) as shown in the picture, then install the magnetic seal (18) on the side and the bottom door seal (13) on the bottom.

B. Install the handle (17) on the sliding door (10) using the hexagonal wrench (27) as shown in the picture.

NOTE:

1. During installation, ensure that the magnetic seal (18) and the bottom door seal (13) fit perfectly with the glass door. Otherwise, the door may not close smoothly or there may be a gap.
2. When installing the roller assembly (24), ensure that the metal parts do not fall on the glass door and cause damage.

07

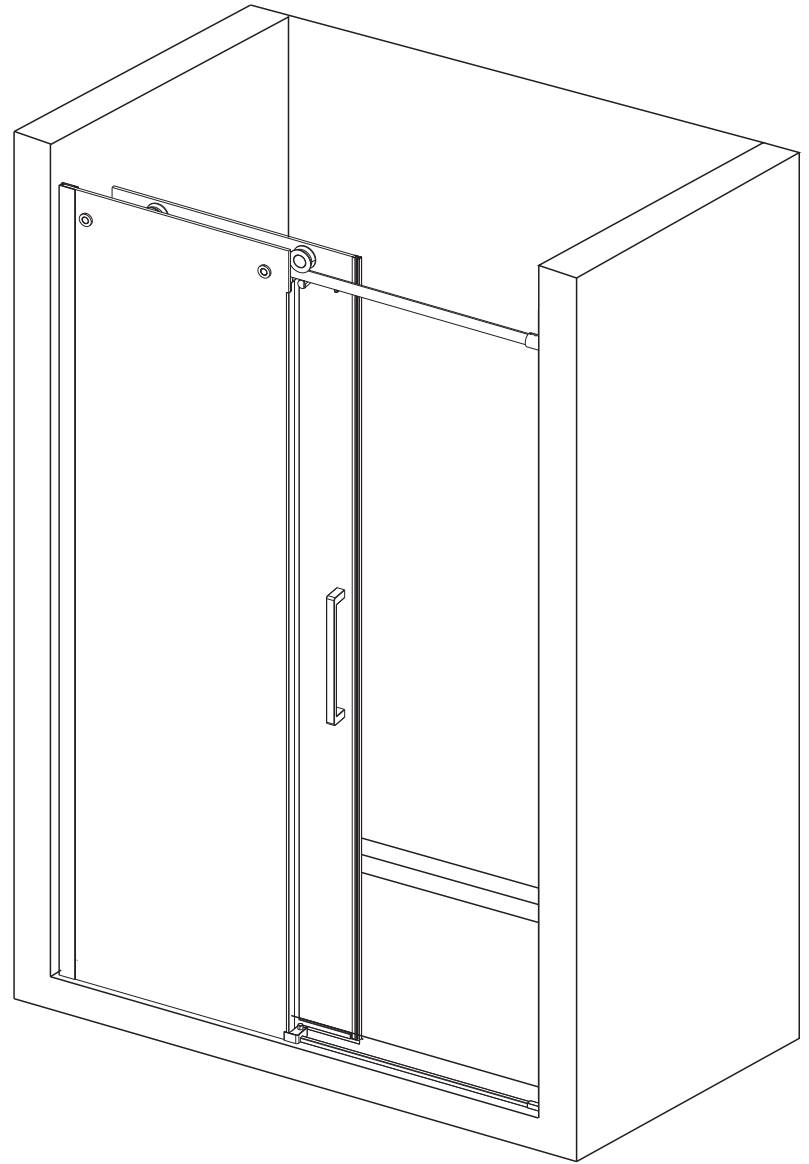
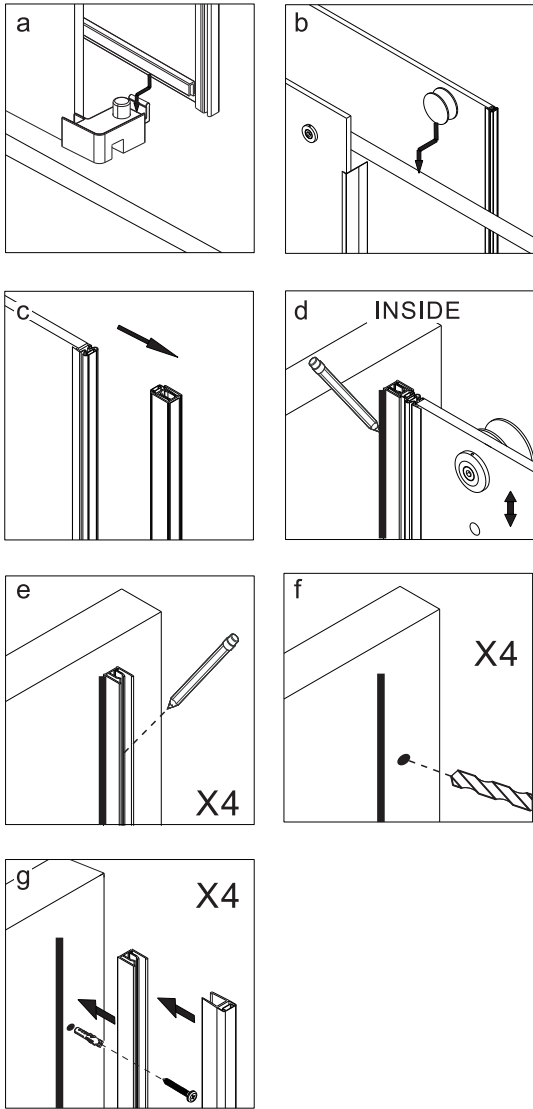
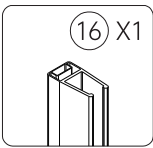
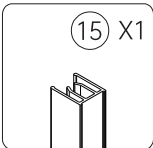
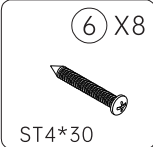
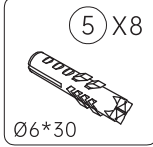

A. After completing the installation in step 6, we need two people to work together to install the sliding door (10) on the top rail (23) as shown in the picture.

B. Attach the magnetic strip on the sliding wall post (15) to the edge of the glass, put on post (16) and then slide the door close to the wall.

C. After it is close to the wall, use a pencil to draw an arc on the inside of the bathroom. At the same time, remove post (16), adjust it horizontally along the drawn position, and then punch along the middle hole.

D. After completing the drilling, insert the expansion bolt (4), then re-align post (16) with the drilling position and tighten it with an electric drill and screw (6).

NOTE:

1. Make sure to wear labor protection gloves, goggles and a mask when drilling.
2. Make sure to draw a line on the inside of the bathroom when confirming it, otherwise the installation position of post (16) will be deviated.

08

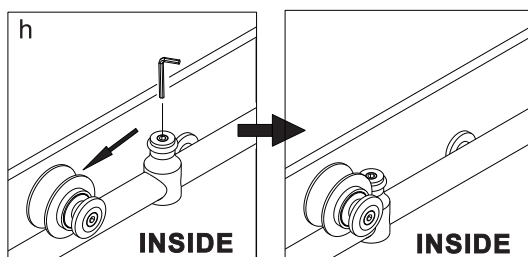
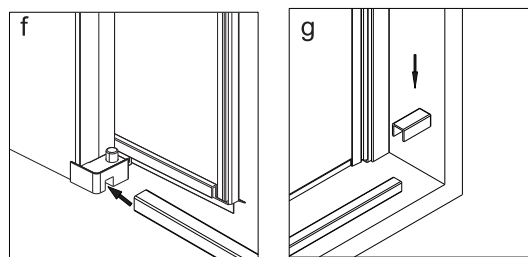
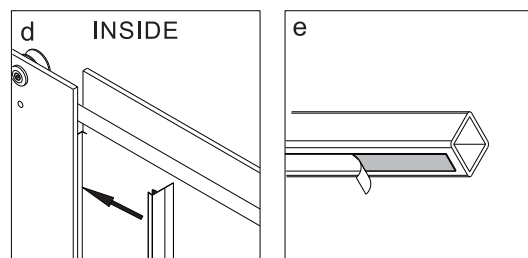
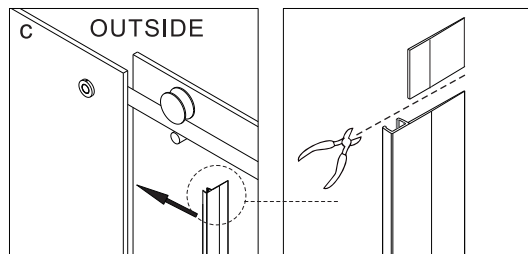
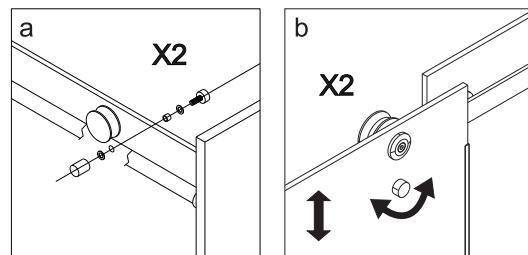
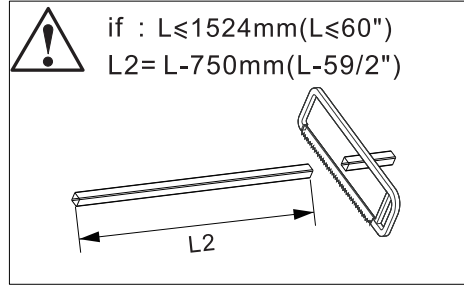
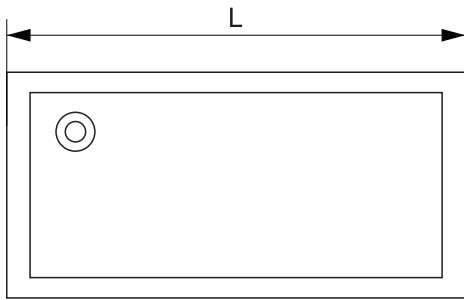
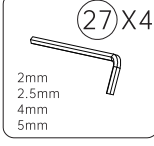
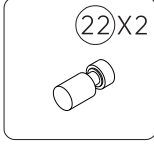
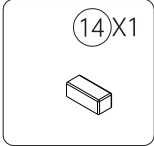
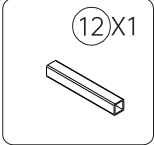
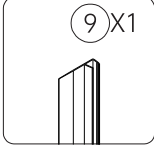
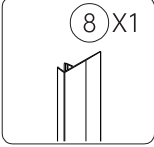

A. In step 3, we confirmed the length of L. Before installing the door threshold bar (12), we need to confirm whether it needs to be cut. According to the formula $L2=L-750\text{mm}$ shown in the picture, use a pencil to mark and cut the excess part.

B. After cutting the door threshold bar (12), install it according to figure f. At the same time, on the other side, install the seal caps (14) according to figure g.

C. Install the anti-drop nail (22) according to figure a. All tightening operations are clockwise.

D. As shown in figure c, door seal A (8) needs to be installed on the outside and door seal B (9) on the inside.

NOTE:

1. During installation, it is necessary to ensure the required cutting length of the door threshold bar (12). If necessary, you can measure and confirm multiple times.
2. The anti-drop nail (22) should be installed on the inside. The installation position can be adjusted according to actual needs.

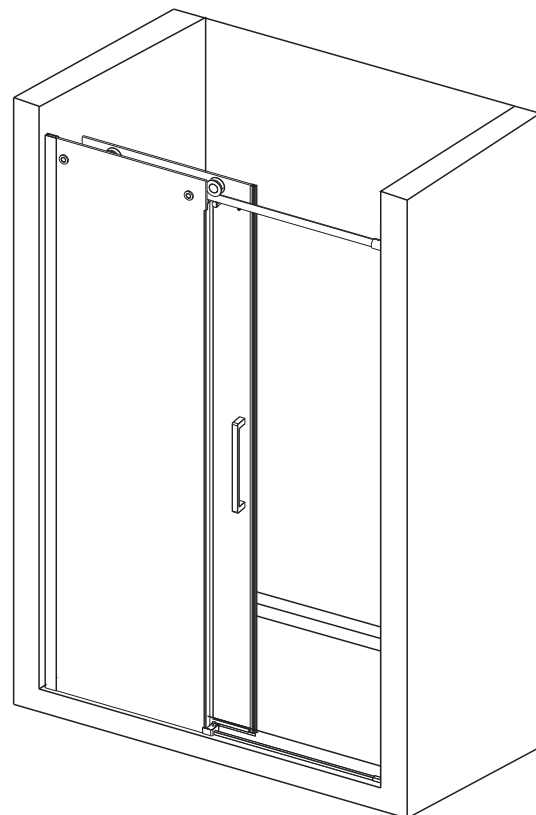

09

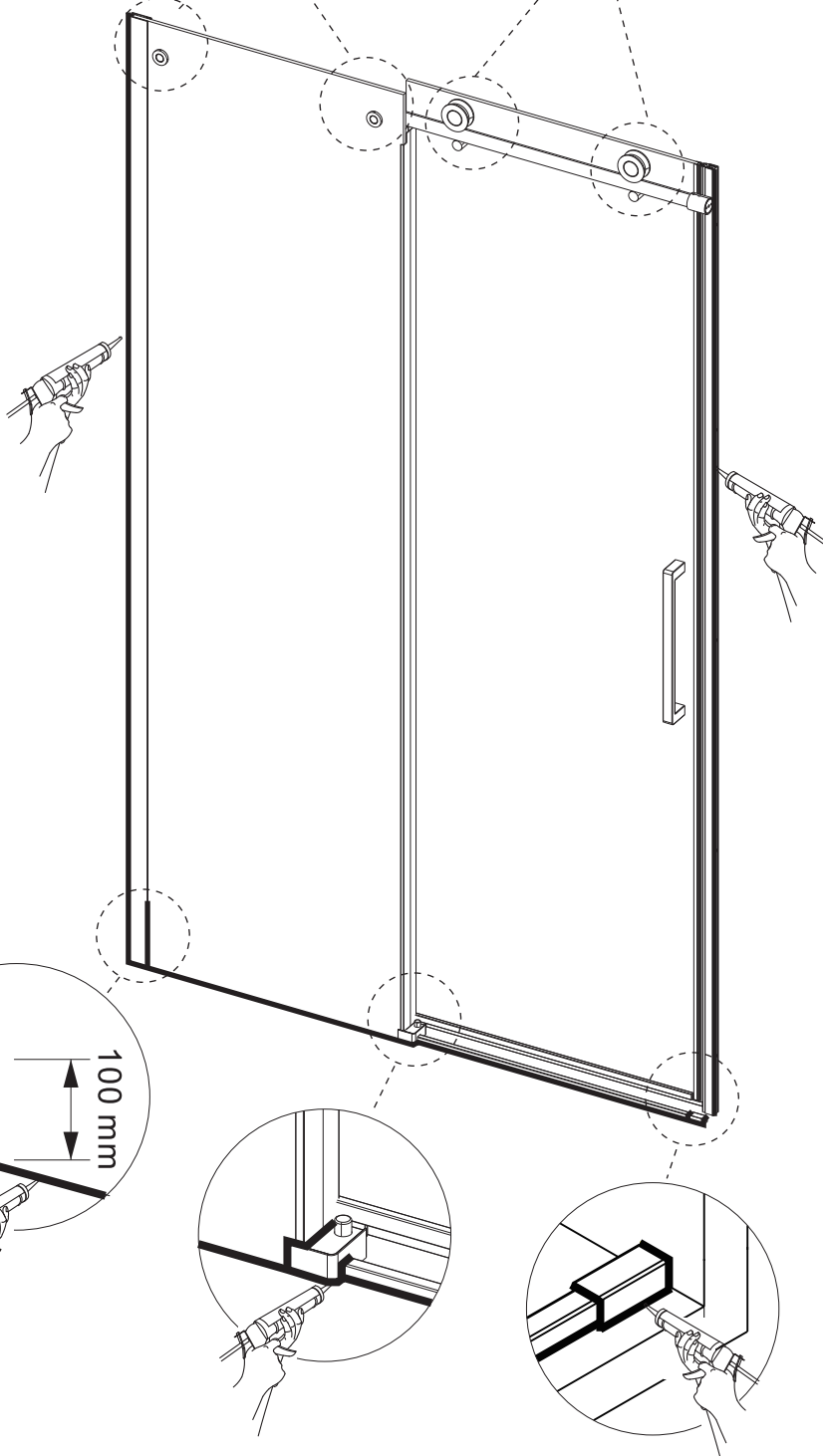
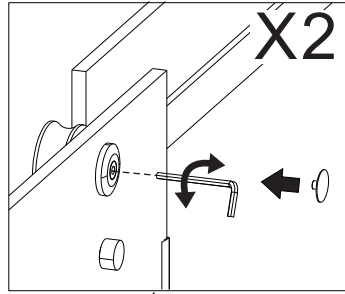
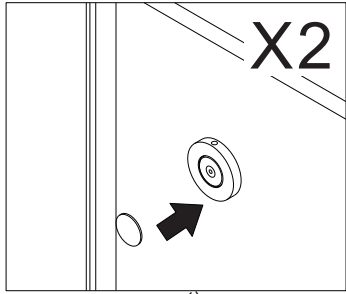
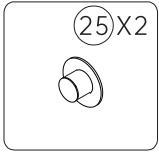
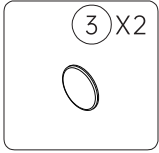

A. After completing the previous eight steps, you need to adjust the entire door. If you feel that there is a gap in the door or it cannot be closed, or the sliding door is tilted, you need to use the hexagonal wrench (27) to adjust the height as shown in the figure.

B. After ensuring that the shower door is fully installed, you need to install the last two parts, cover A (3) and cover B (25), on the fixed glass bolt assembly (2) and roller assembly (24) respectively.

C. After completing all steps, you can apply glue to the entire edge of the shower door.

NOTE:

1. Make sure to wear labor protection gloves, goggles and a mask when applying glue.
2. Remember not to use the shower door within 24 hours after applying glue, otherwise the glue will become ineffective.

TROUBLESHOOTING GUIDE AND NOTE

If not installed correctly, the following issues may arise.

- **Water leaks in the door overlap areas**

Solution: Make sure the side anti-water strip, where the double doors overlap, is flush with the bottom glass to prevent water from flowing out of the overlap.

- **Water leaks in the door bottom areas**

Solution: Please confirm anti-splash threshold silicone seals well without leaking, then the following adjustment may need to be done.

1. Adjust the angle of the shower head so that the shower water from directly wash the bottom of the sliding glass and the glass body.

2. Regular Inspection: In order to prolong the lifetime of the shower door, please check the glass and all hardware regularly for shifting/damage/noisy sliding/screws loose, to avoid incorrect installation that causes damage beyond control. If you have any questions, please contact us.

- **The sliding door panel is difficult to move**

Solution: It is necessary to check whether the bottom of the door panel and the bottom guide are installed correctly. If they are not installed properly, the door panel may become loose or even difficult to move.