

# Assembly Instruction

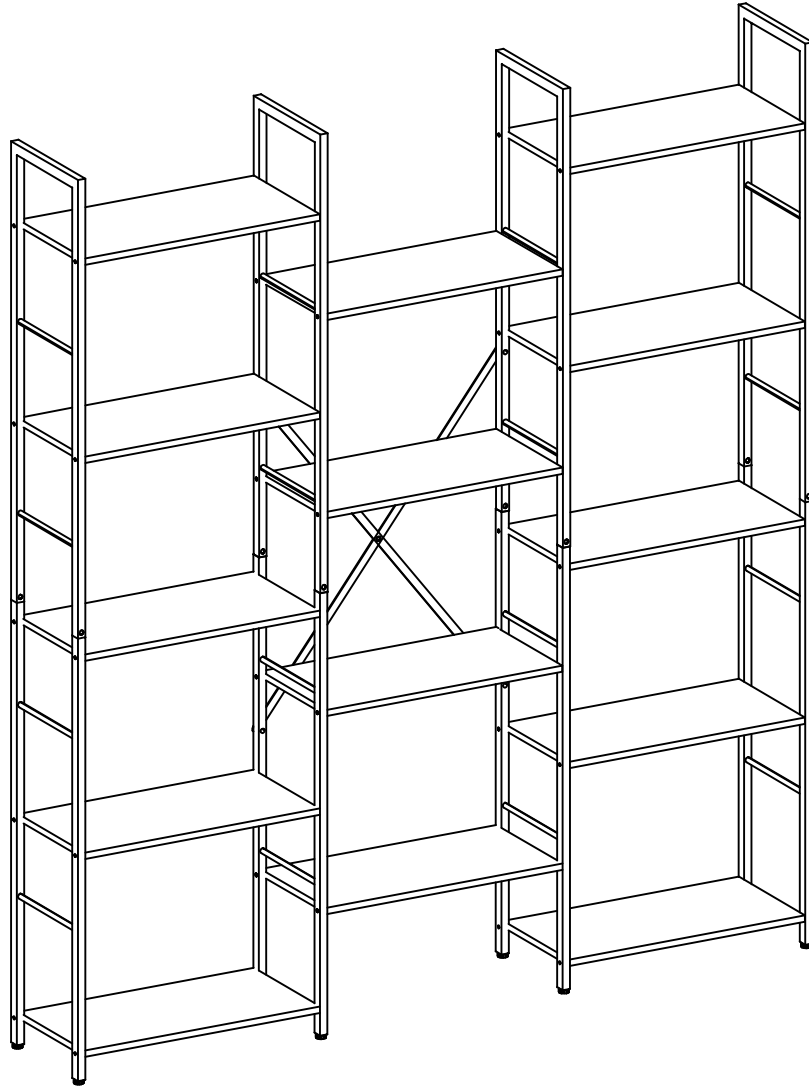

## Instruction Manual

Thank you for shopping with us!

We appreciate your purchase and are ready to be at your service!

if you find parts missing, broken, or hard to put together or when you are not satisfied or have any valuable suggestions, please do not hesitate to contact us first!

We will definitely give you a satisfactory solution or answer then!

Contact us at our after-sales service email.

**COMPONENTS ID Nr.**

Part Nr.	Qty	Part Nr.	Qty	Part Nr.	Qty
A	14pcs				

T01	2pcs	T02	2pcs	T03	2pcs
T04	2pcs	T05	2pcs		

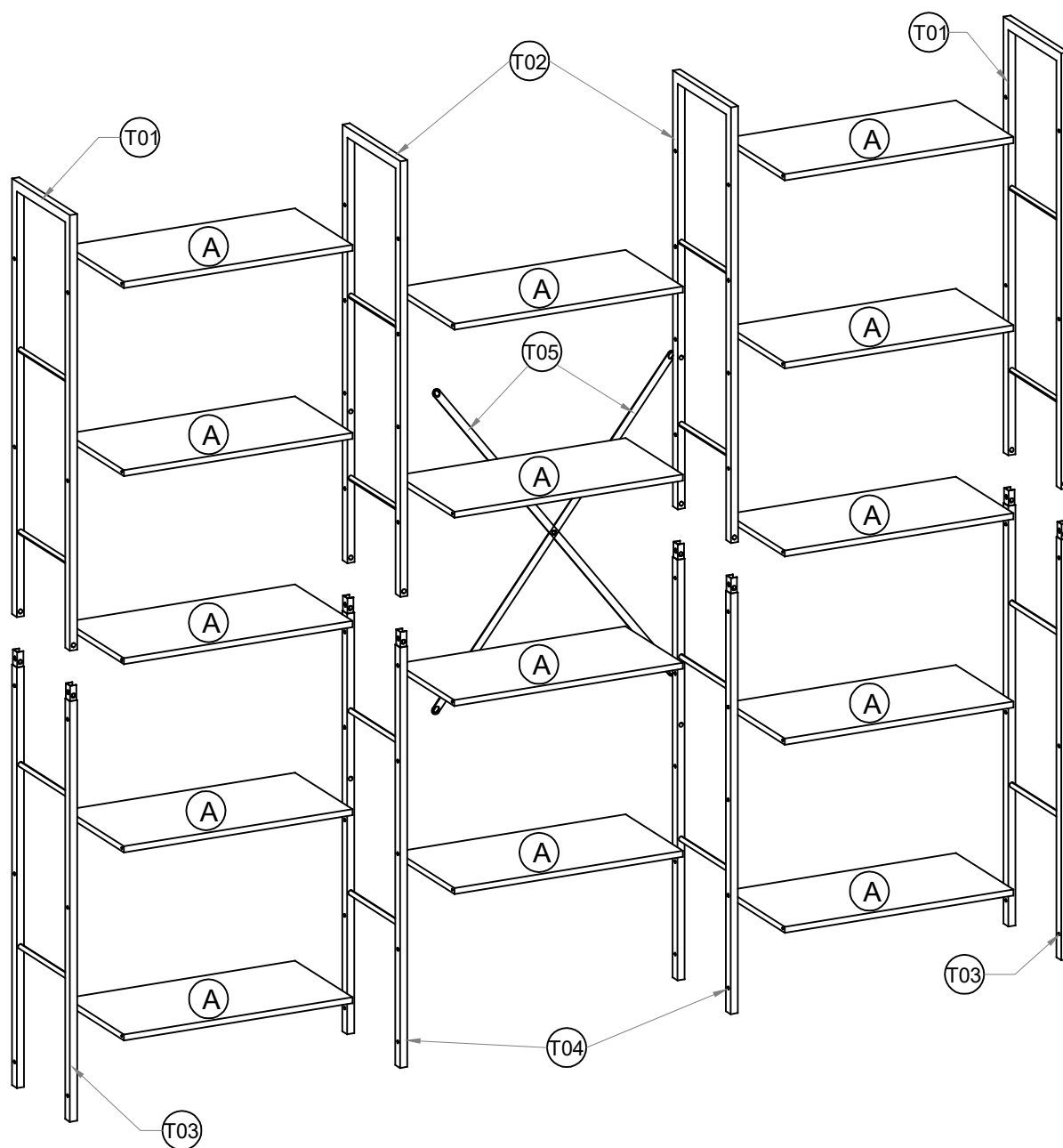

# PRODUCT ASSEMBLY

A x 14

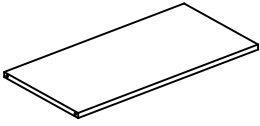

T01 x 2



T02 x 2

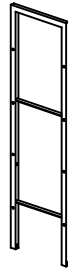

T03 x 2

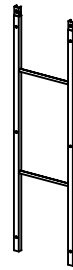



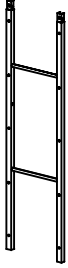

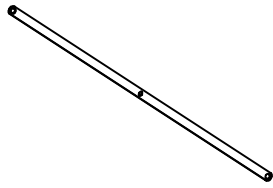

T04 x 2

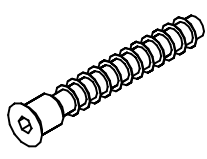

T05 x 2

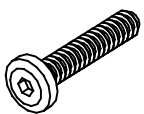
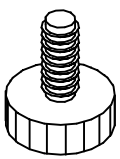

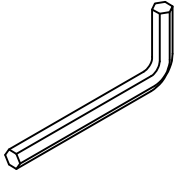
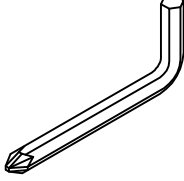
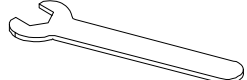
# HARDWARE LIST

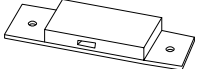
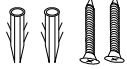
<p>① x 56</p>  <p>D5x40mm</p>	<p>② x 1</p>  <p>M6x10mm</p>	<p>③ x 12</p>  <p>M6X30mm</p>	<p>④ x 8</p>  <p>M6x25mm</p>
<p>⑤ x 13</p>  <p>M6</p>	<p>⑥ x 1</p>  <p>3#</p>	<p>⑦ x 1</p>  <p>4#</p>	<p>⑧ x 1</p>  <p>10MM</p>
<p>⑨ x 2</p>   			

1



Note: Two holes are here at the same side.

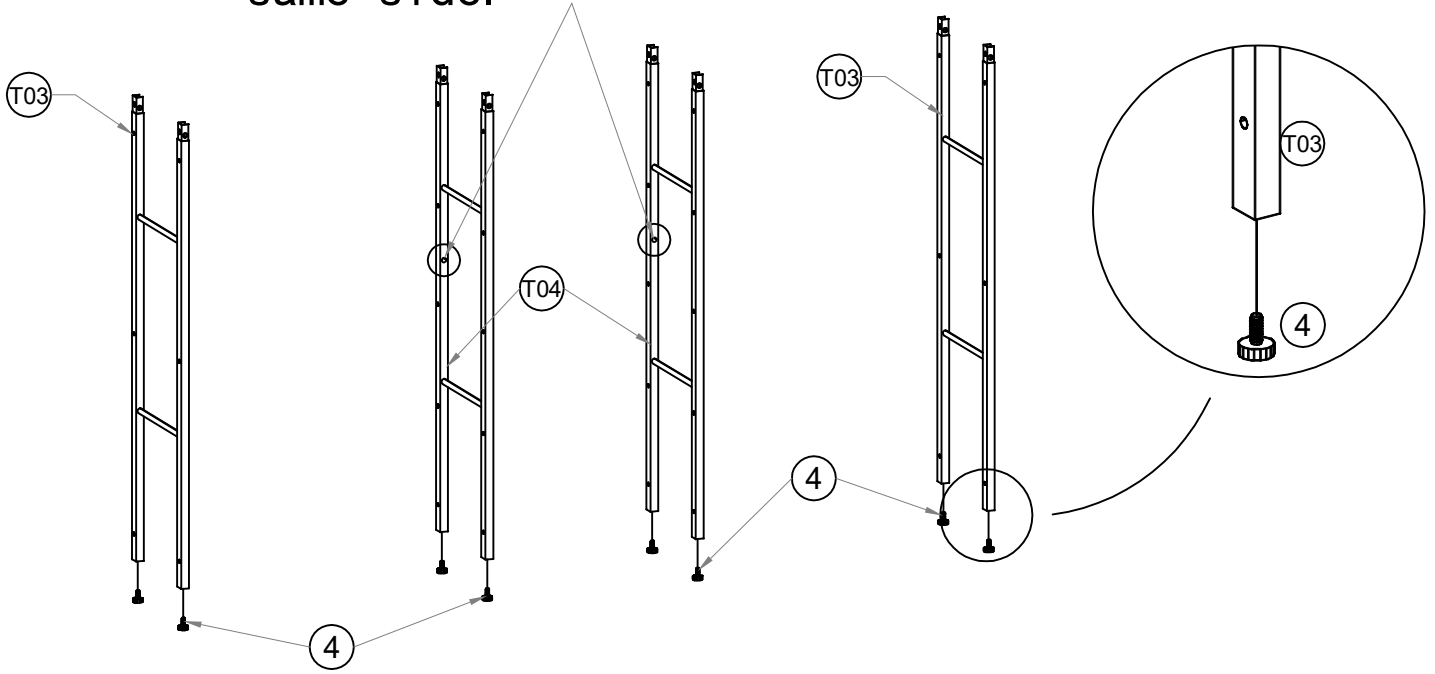

2

D5x40mm

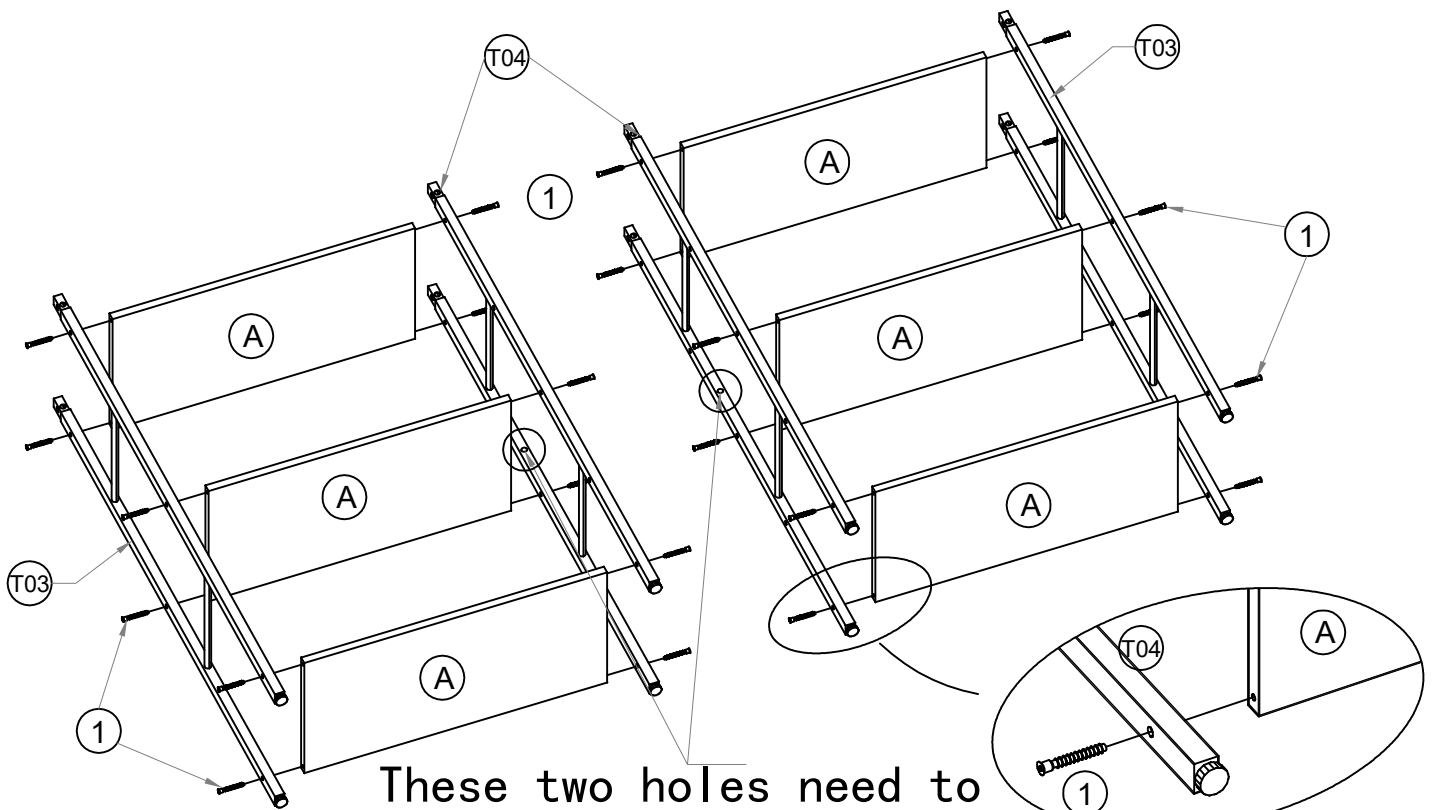
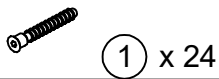

These two holes need to be at the same side.

3

M6x30mm

M6



3 x 8



5 x 8

These four holes need to be at the same side.

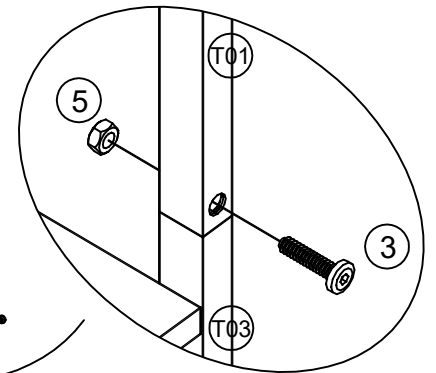
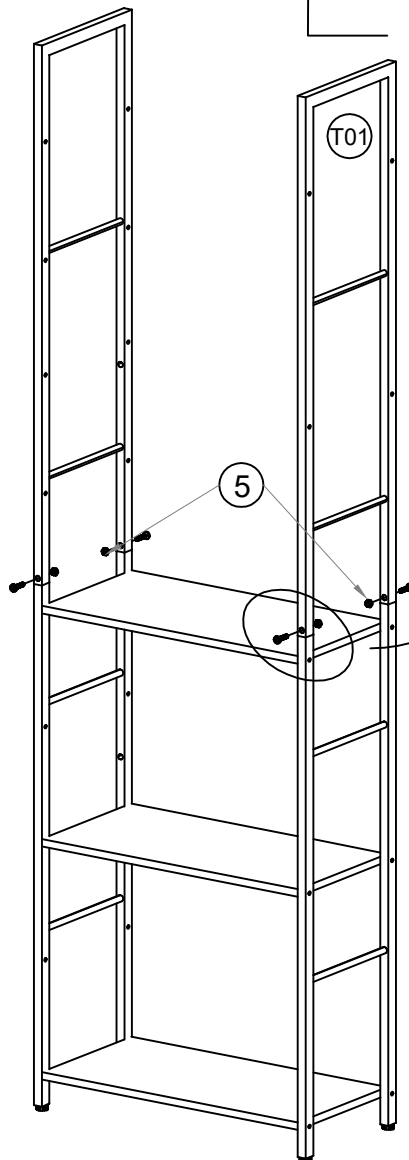
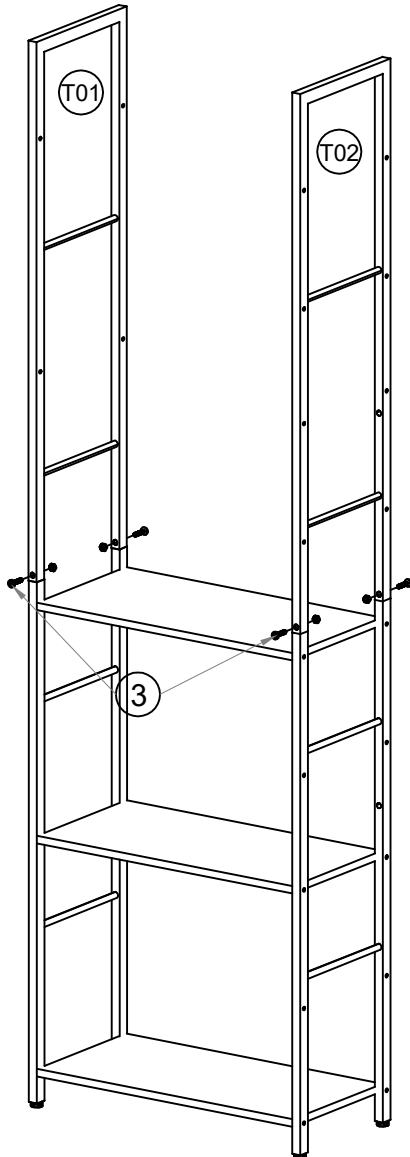
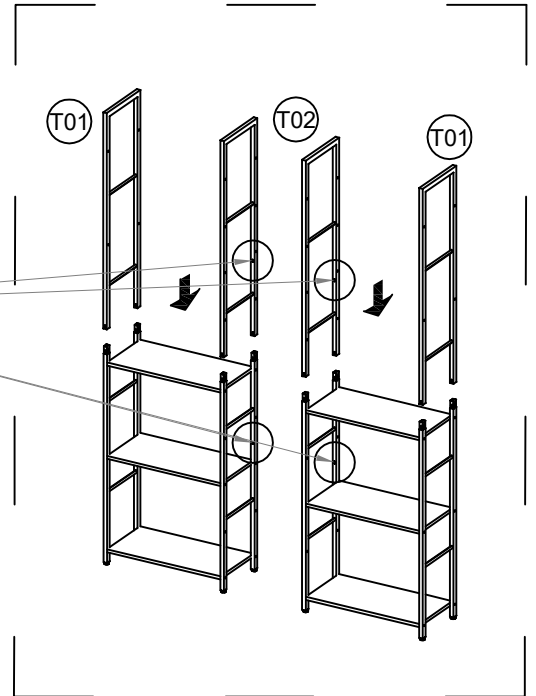

4

D5x40mm



① x 16

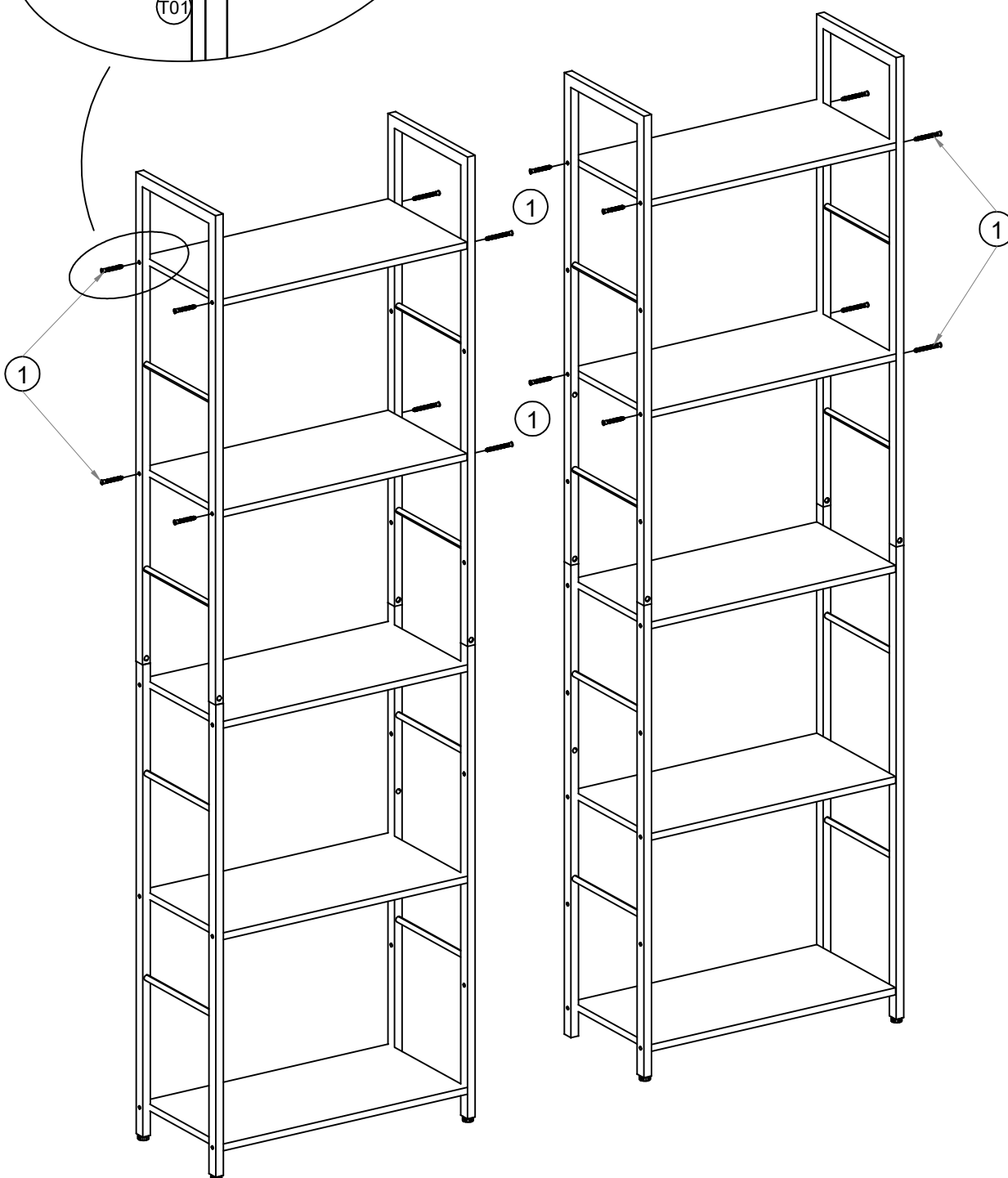
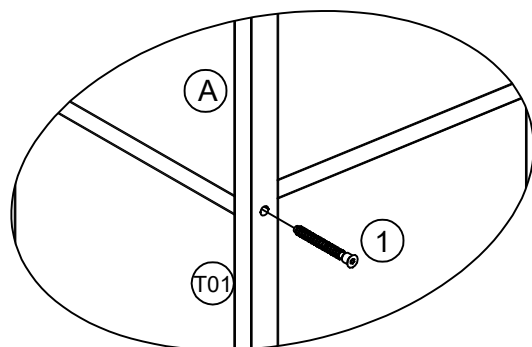

5

D5x40mm



① x 16

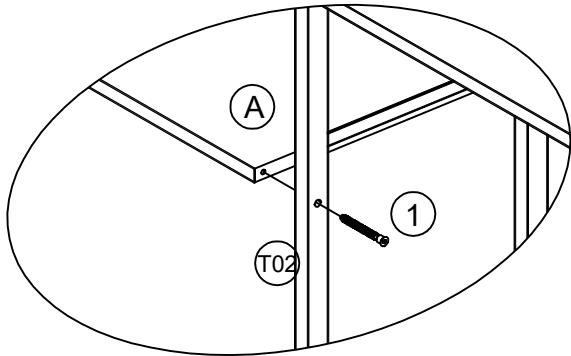

These four holes face back.

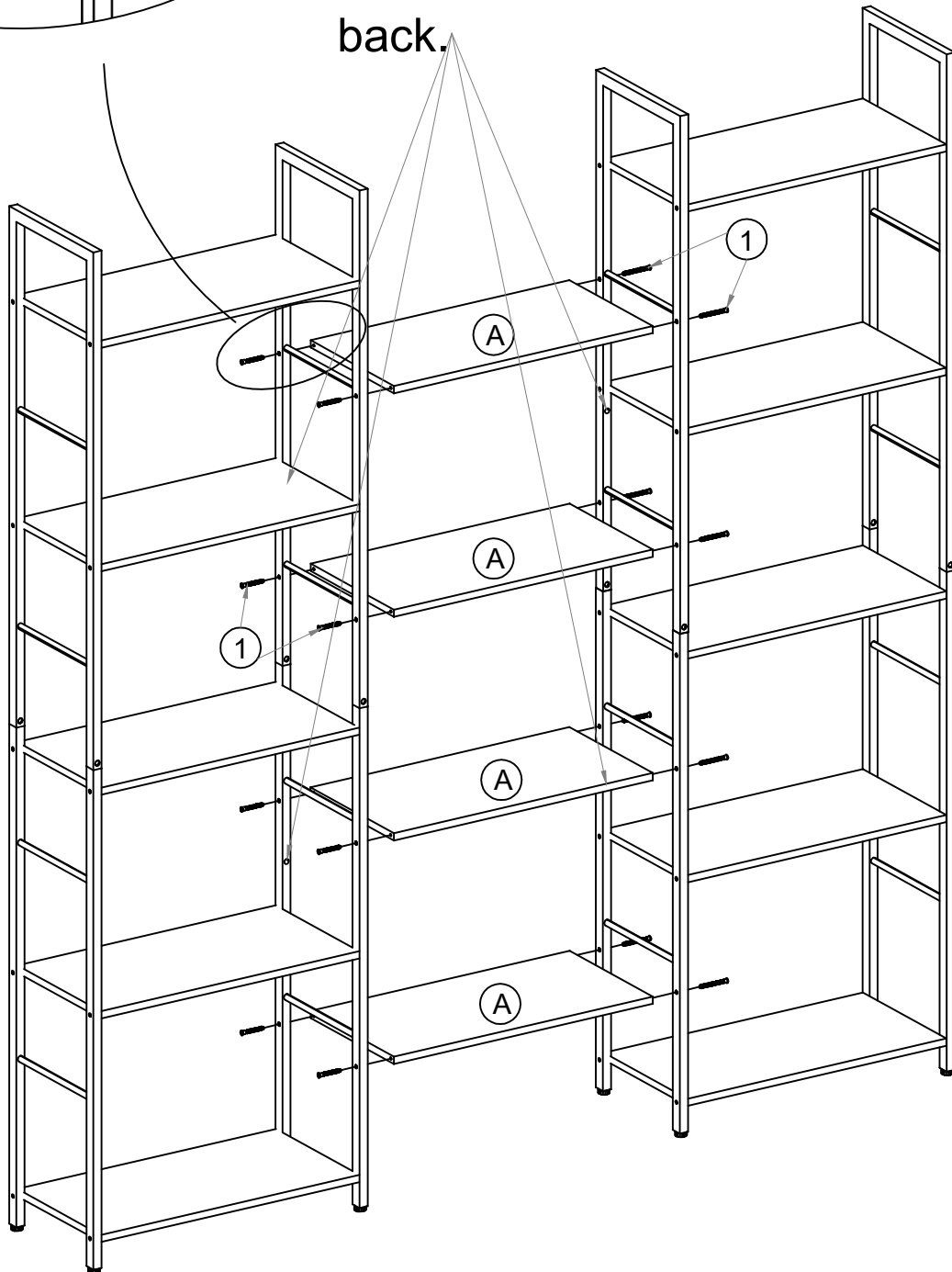

6

M6x30mm

M6x10mm

M6



3 x 4



2 x 1



5 x 5

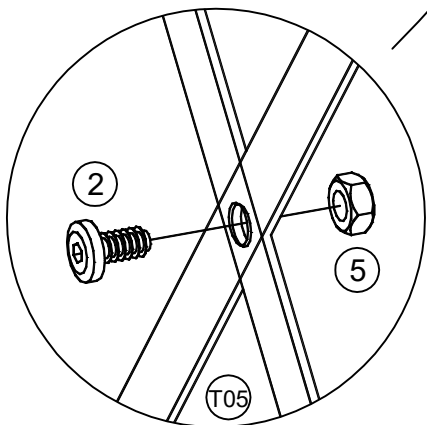
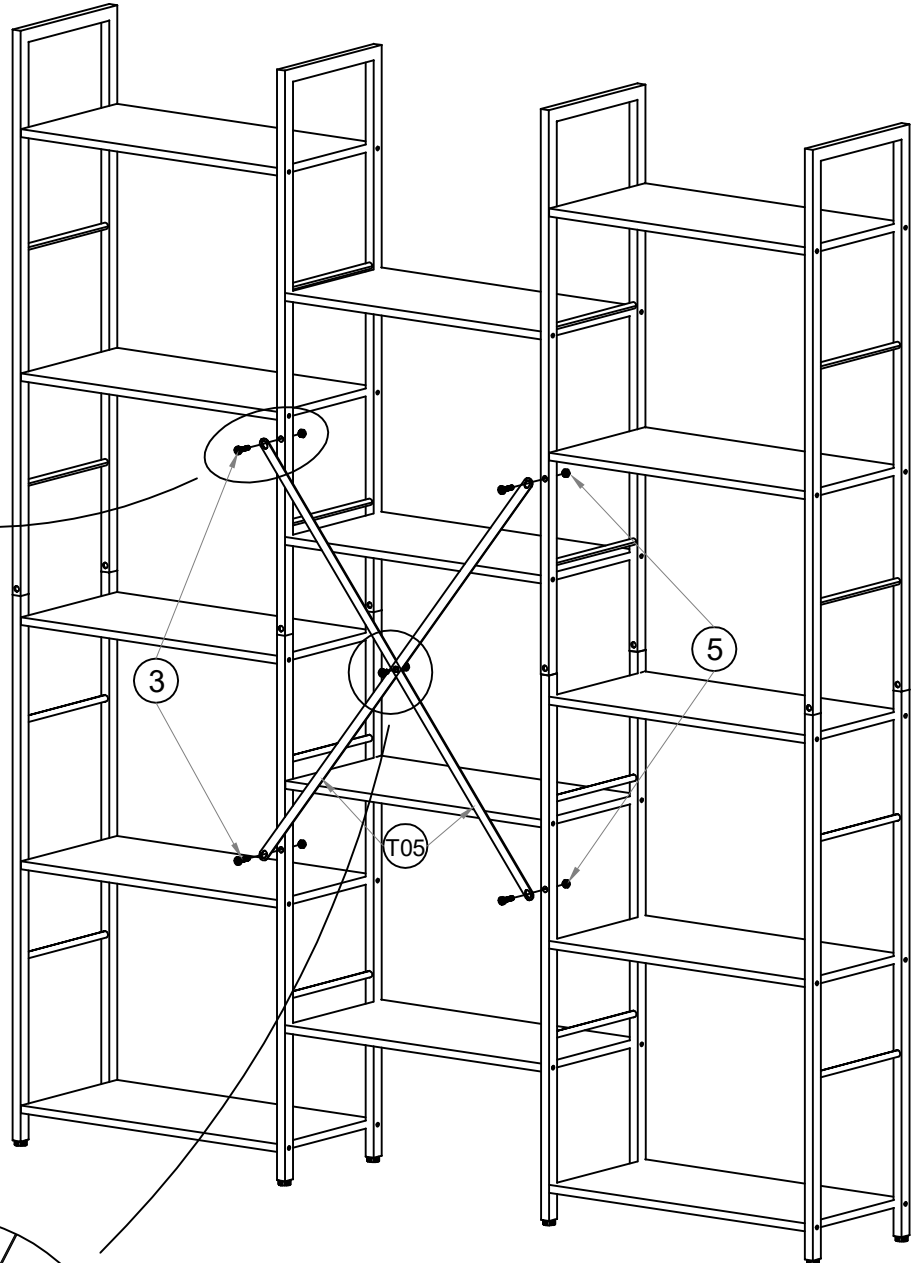
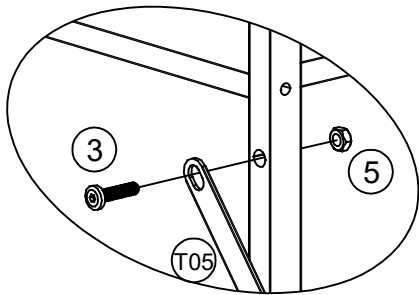

7



WALL

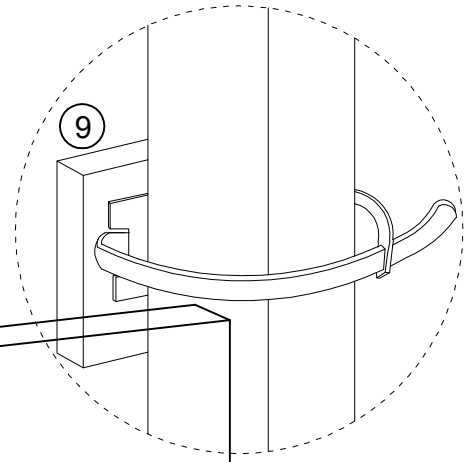
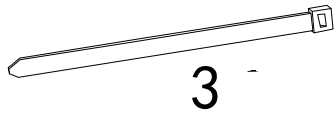
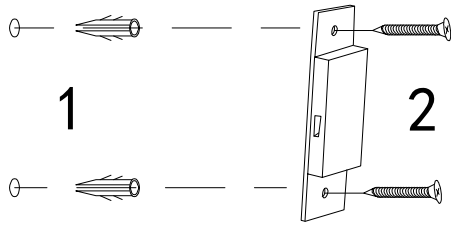

WALL

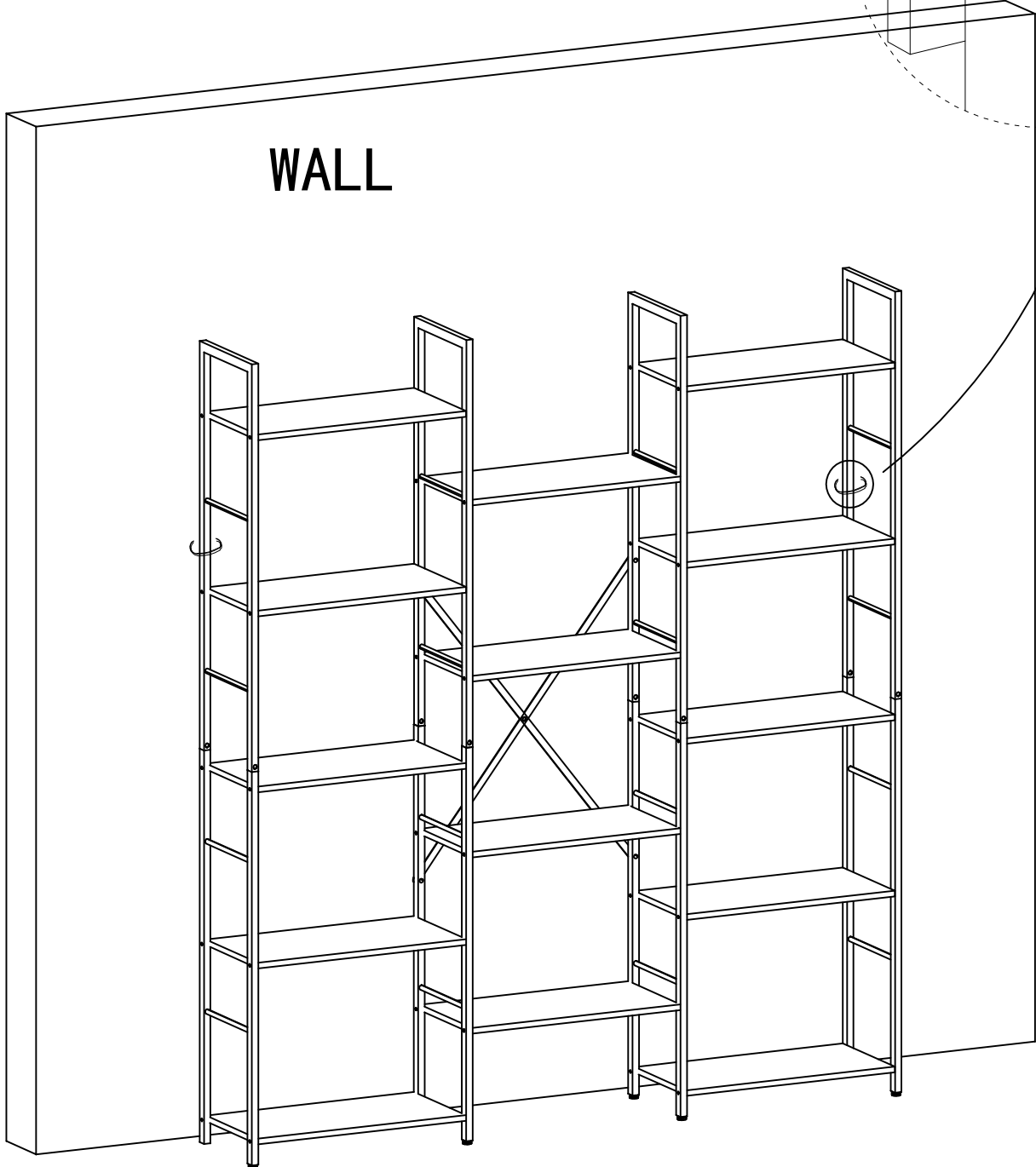

# 8

## Finished assembly

