

INSTALLATION INSTRUCTIONS

Storage Shed

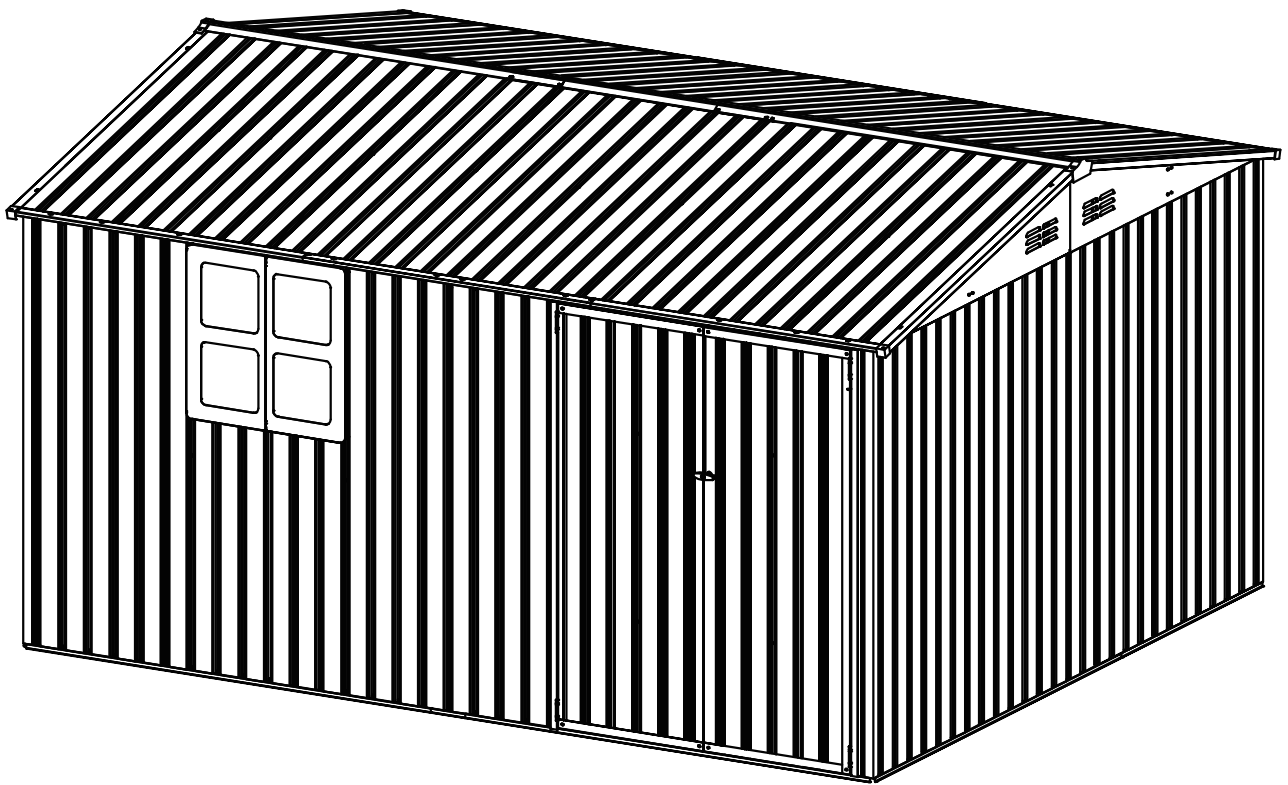

 VIWATCustomerService@gmail.com

Our team is available 24/7 to help with any product questions. Contact us anytime!

REQUIRED TOOLS

Tools			
	Gloves	Table	Ladder
			
	Power drill	Screw drive	Tape Measure







ASSEMBLY TIPS

1. Clear a working area to allow access on all four sides. A raised work surface will make assembly easier. It is easier to install the wall panel on the table.
2. All parts are identified, so when working through the instructions page by page, the diagrams show where each part is positioned.
3. Before starting, to avoid any accidental injury, we recommend the use of gloves to protect your hands.
4. Please keep children away from your construction site.
5. Most assembly can be completed by one person, but assistance may be needed when you reach the erection stage.
6. Please note: Some local government authorities have rules & regulations on shed installation, and you may need approval to erect this shed.

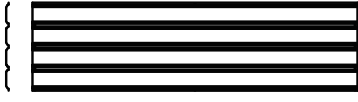





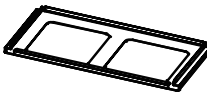

















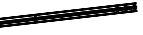

ASSEMBLY STEPS

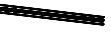











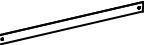

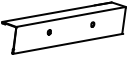









1. Unpack all components from the carton and lay them out beside your work area. Check parts against the parts list.
2. Work through the assembly instructions page by page.
3. Once assembly is completed, place the shed in position and fix the anchor to the ground.
4. Clean up all metal pieces and screws.

F1209parts list(A)

PART	NO.	QTY.
	W5-D	21
	F1209-7L	2
	F1209-7M	12
	F1209-7R	2
	W5-G	1
	W5-KD	2
	TCH	2

F1209parts list(B)

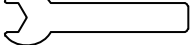
PART	NO.	QTY.
	W5-CD	4
	W3-D	1
	W3-G	1
	W2-HLD	1
	W2-HRD	1
	F1209-7MM	2
	K810-1	2
	K810-1R	2
	K810-2	2
	F1209-2R	2
	K810-3L	2
	K810-3	2
	K810-4	2
	F1209-4R	2
	F1209-5L	2
	F1209-5R	2
	K812-6L	6
	K812-6R	6
	K812-6M	6
	F1209-8	4
	F1209-9L	2
	F1209-9M	2
	F1209-9R	2
	K812-10	2
	K812-10M	1
	UAG	2

PART	NO.	QTY.
	DAG	2
	DLAD	1
	DRAD	1
	DDA	4
	DBD	4
	C3	4
	K1012-11	8
	TCH3	1
	TCH5	1
	TCH6	1
	TCH7	1
	GC	4
	GE	2
	T-F	4
	DC	2
	C2	4
	DJ	4
	F1	581
	F2	101
	F4	4
	V2	196
	GL	1
	SL	110
	M20	1
	ST	2

Sort By Splicing

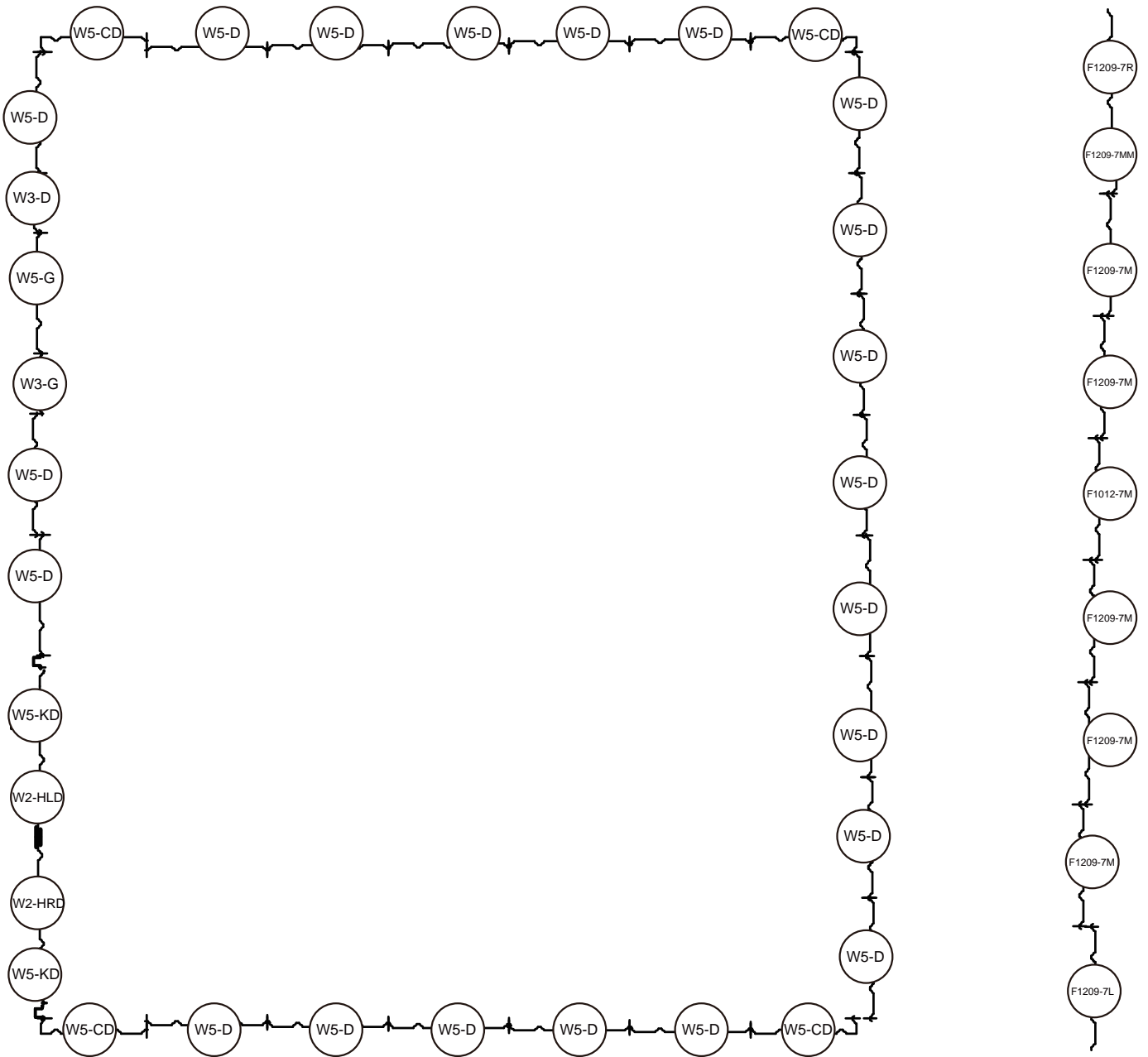

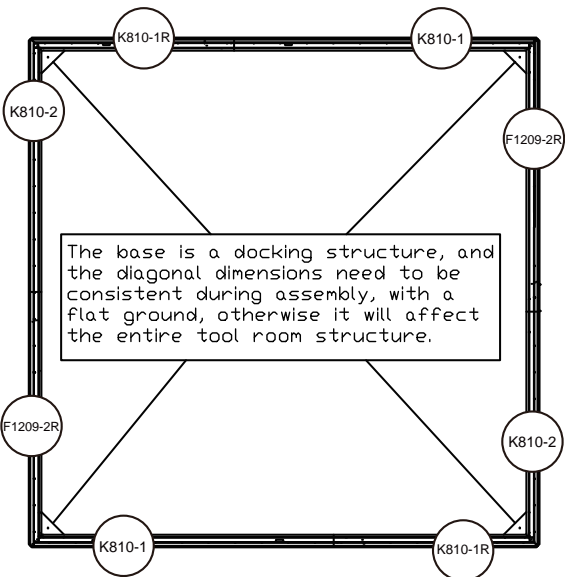
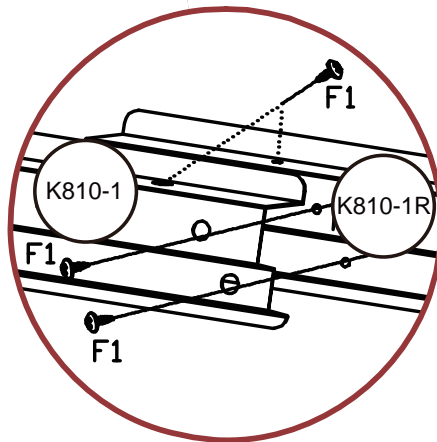
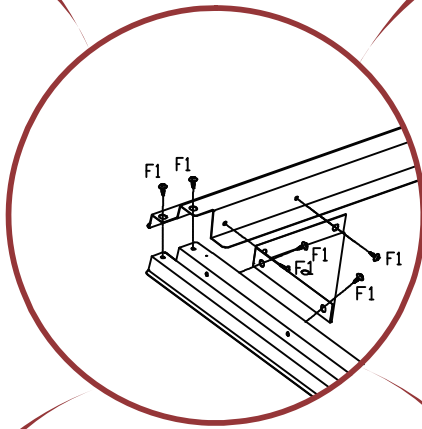
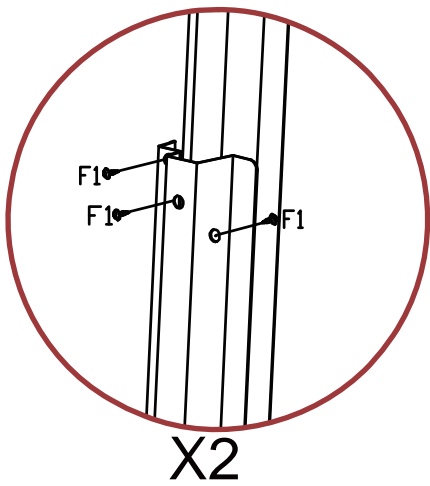
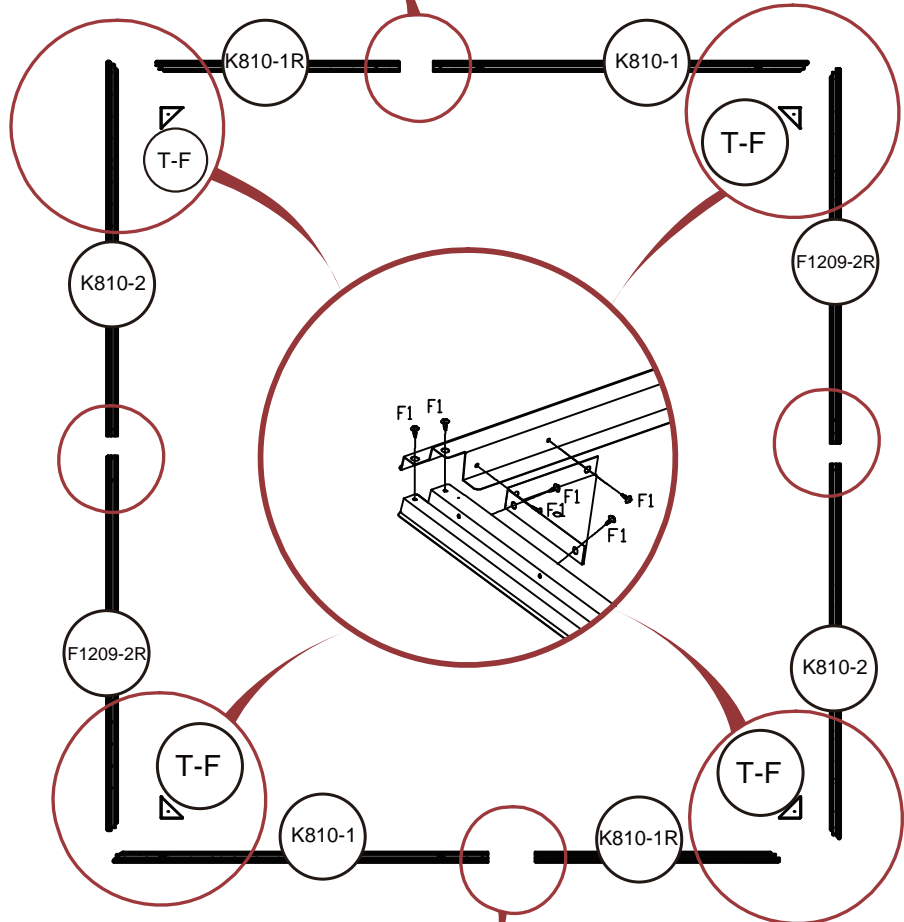
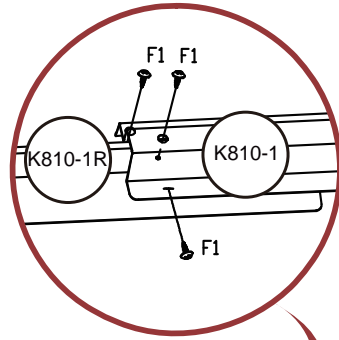

STEP 1

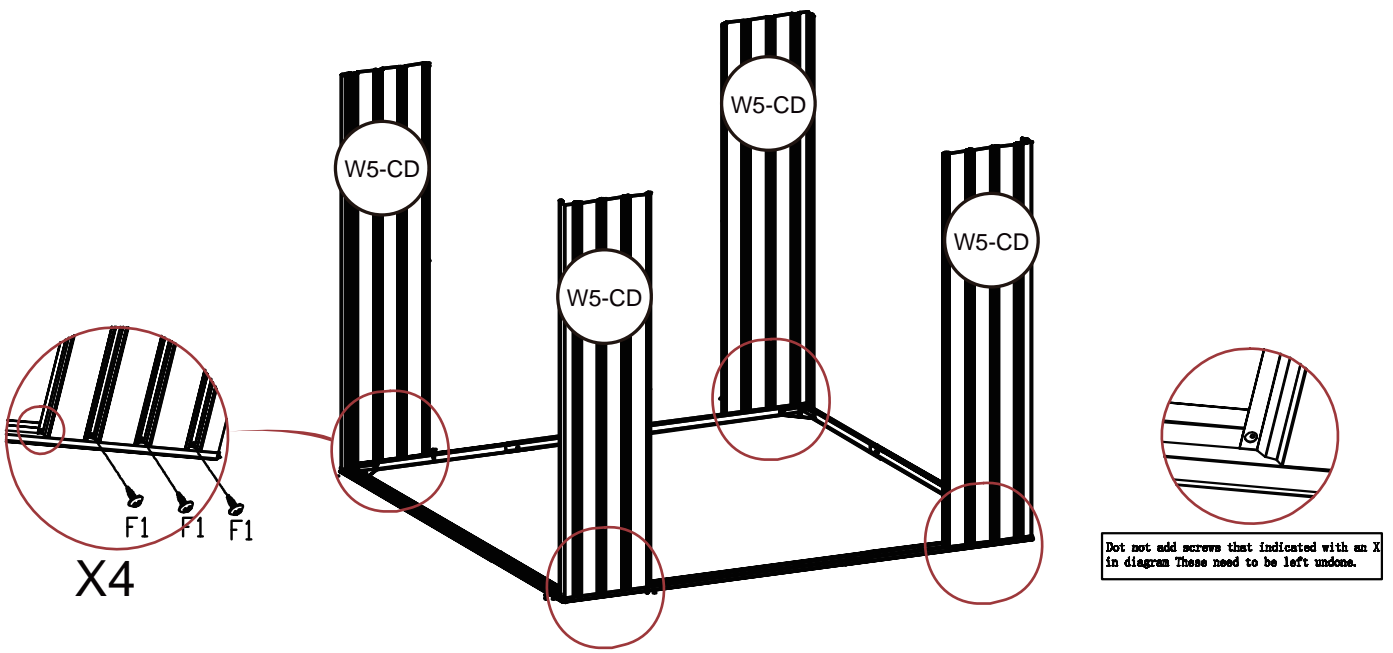
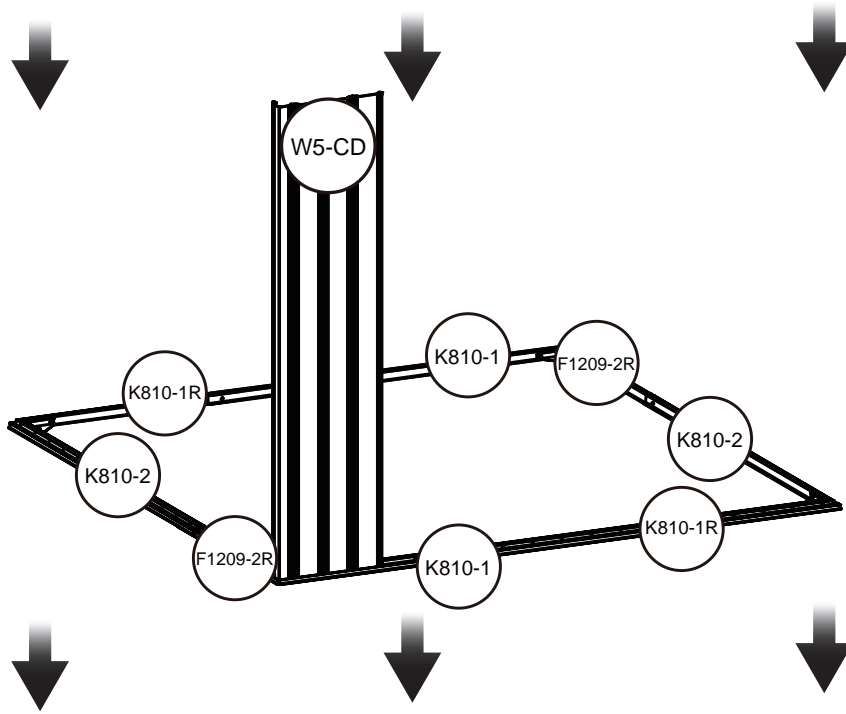
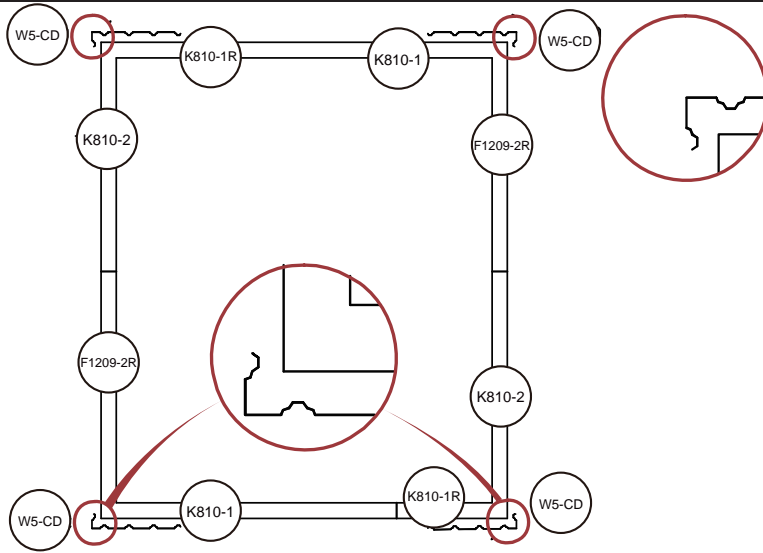

	F1	36
---	----	----

STEP 2



	F1	12
---	----	----

STEP 3

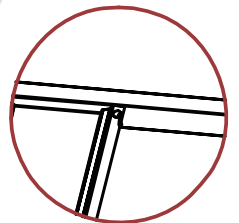
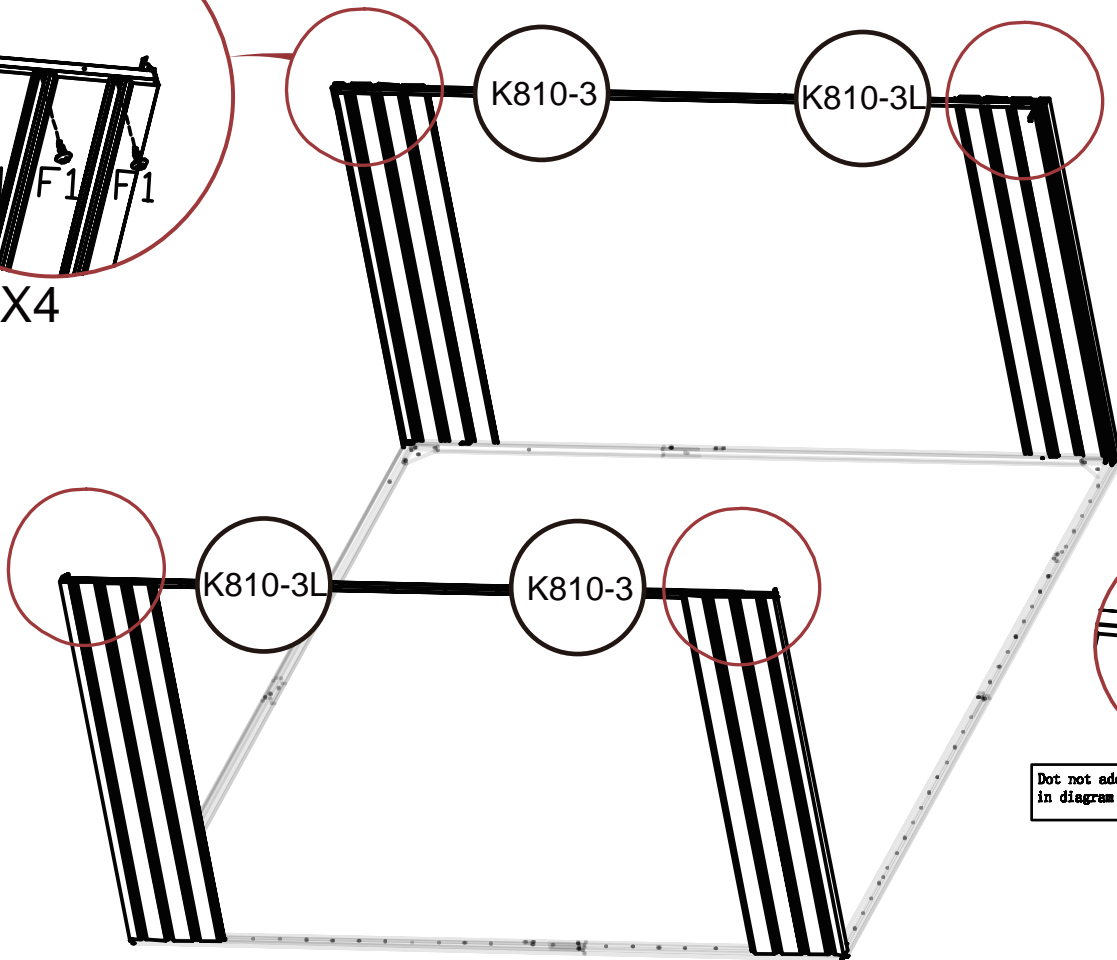
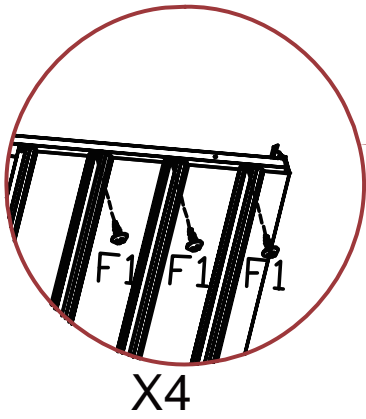
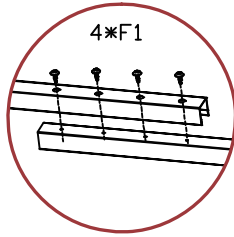
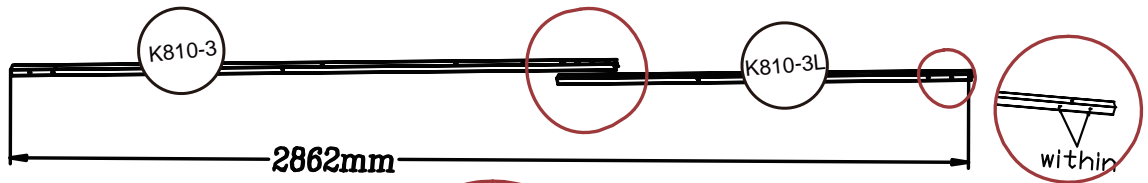

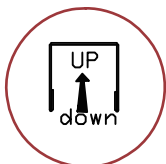
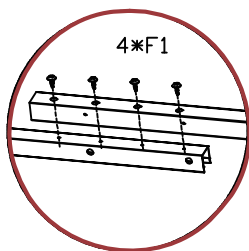

Do not add screws that indicated with an X in diagram. These need to be left undone.

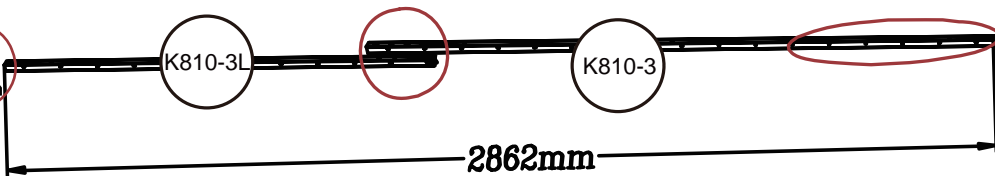

UP

down



	F1	20
---	----	----

STEP 4

X2

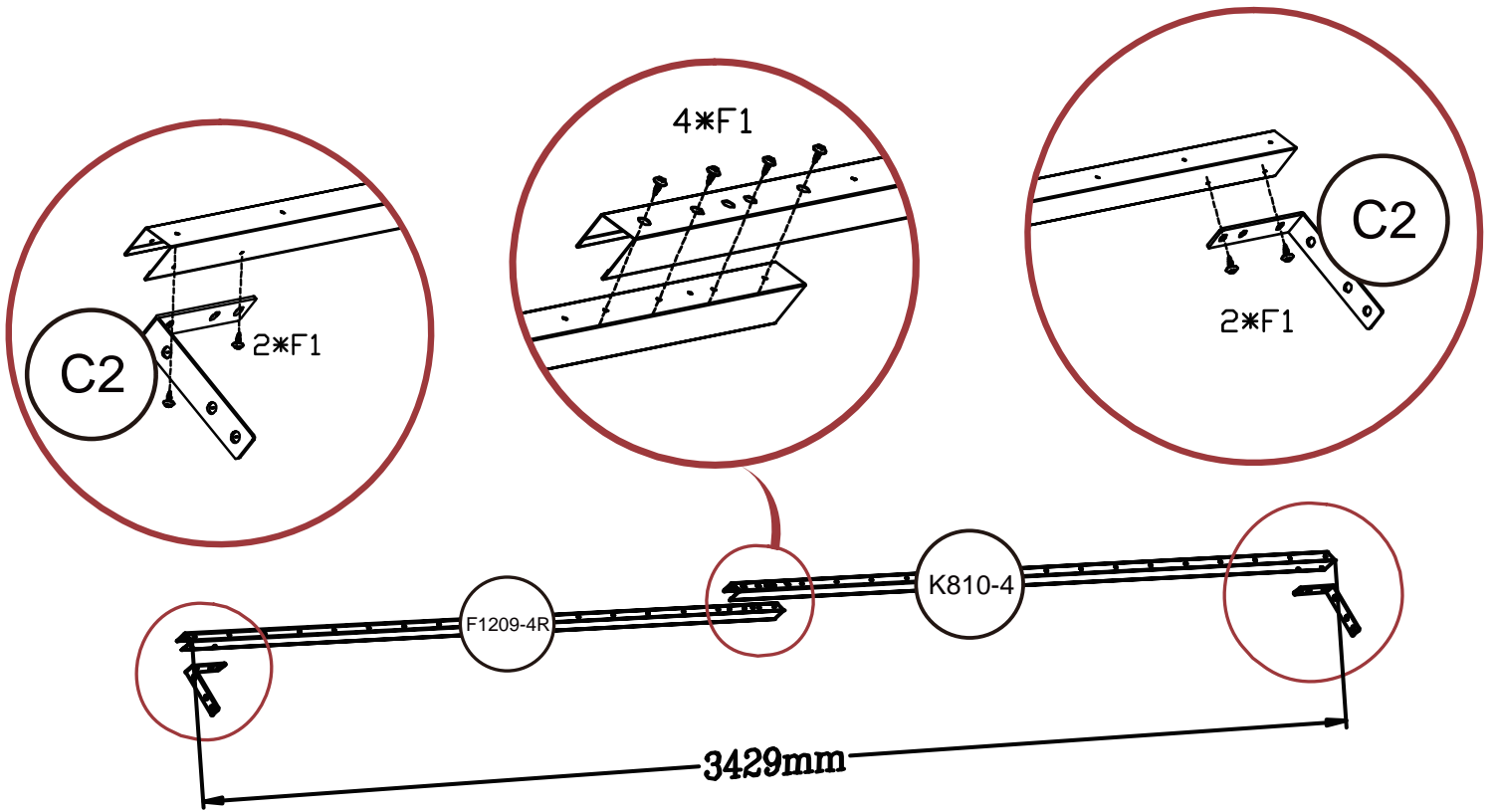

	F1	16
---	----	----

STEP 5

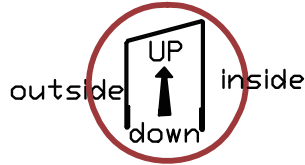
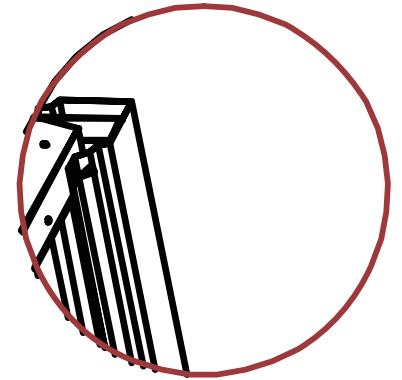
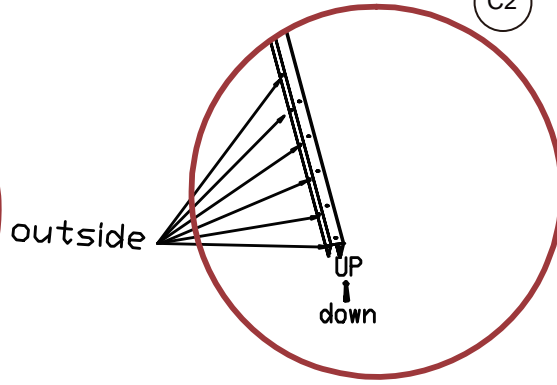
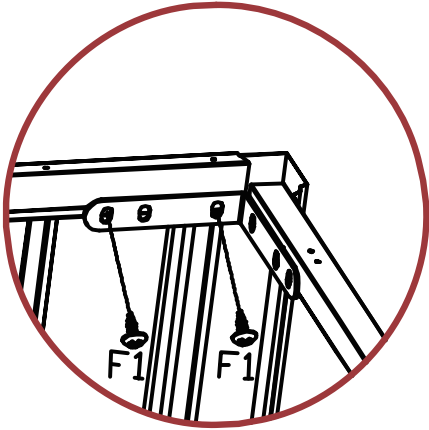
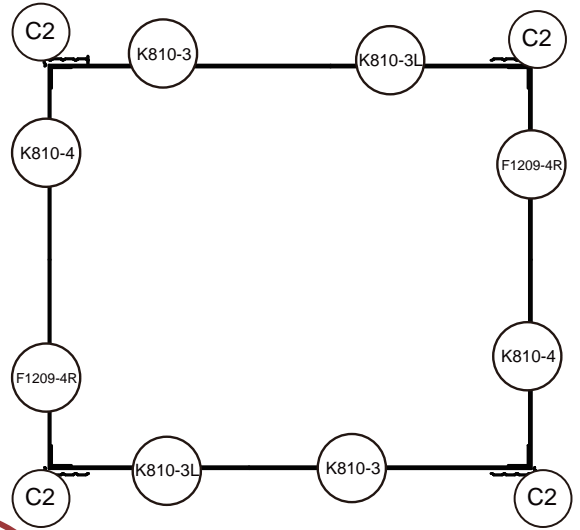

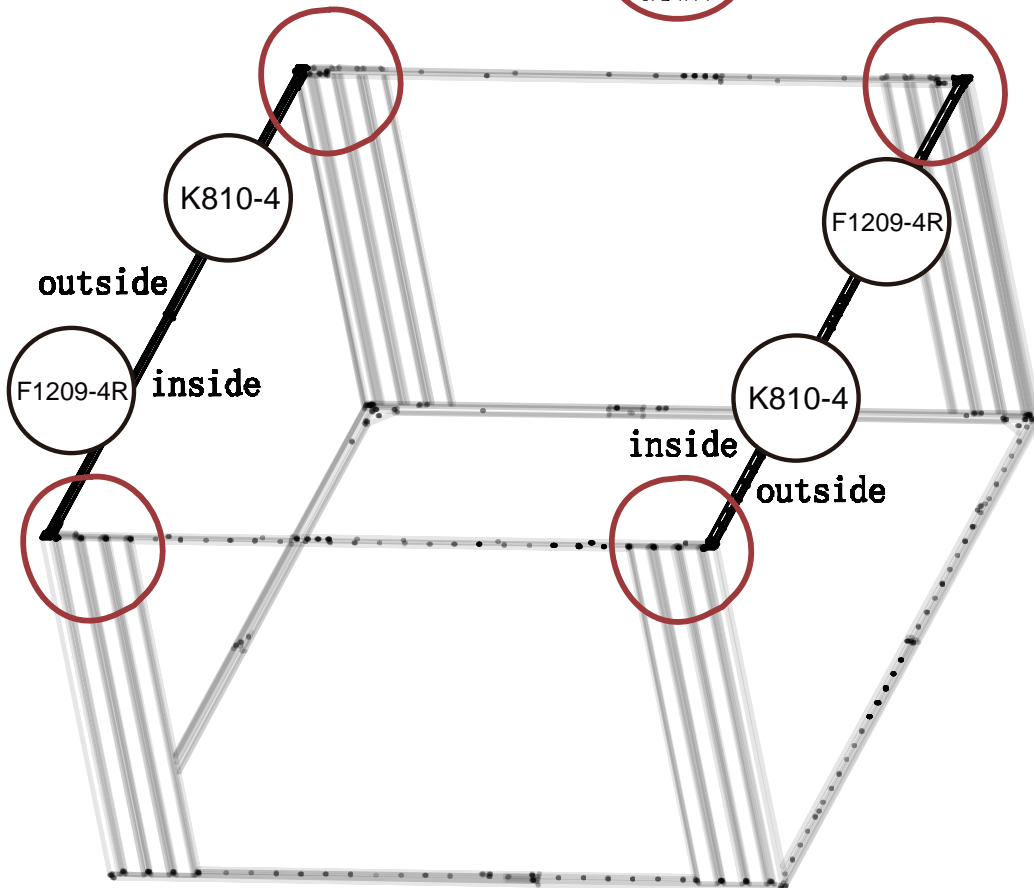

Do not add screws that indicated with an X in diagram. These need to be left undone.



	F1	8
---	----	---

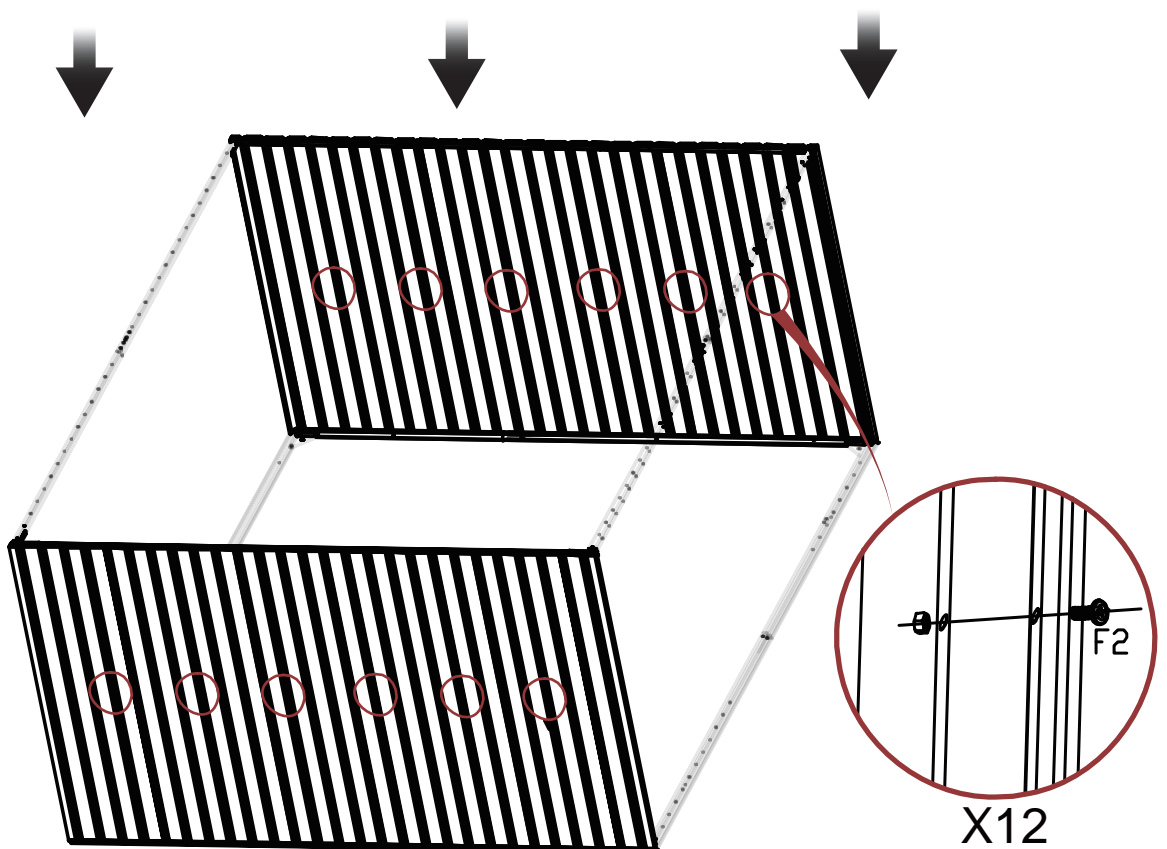
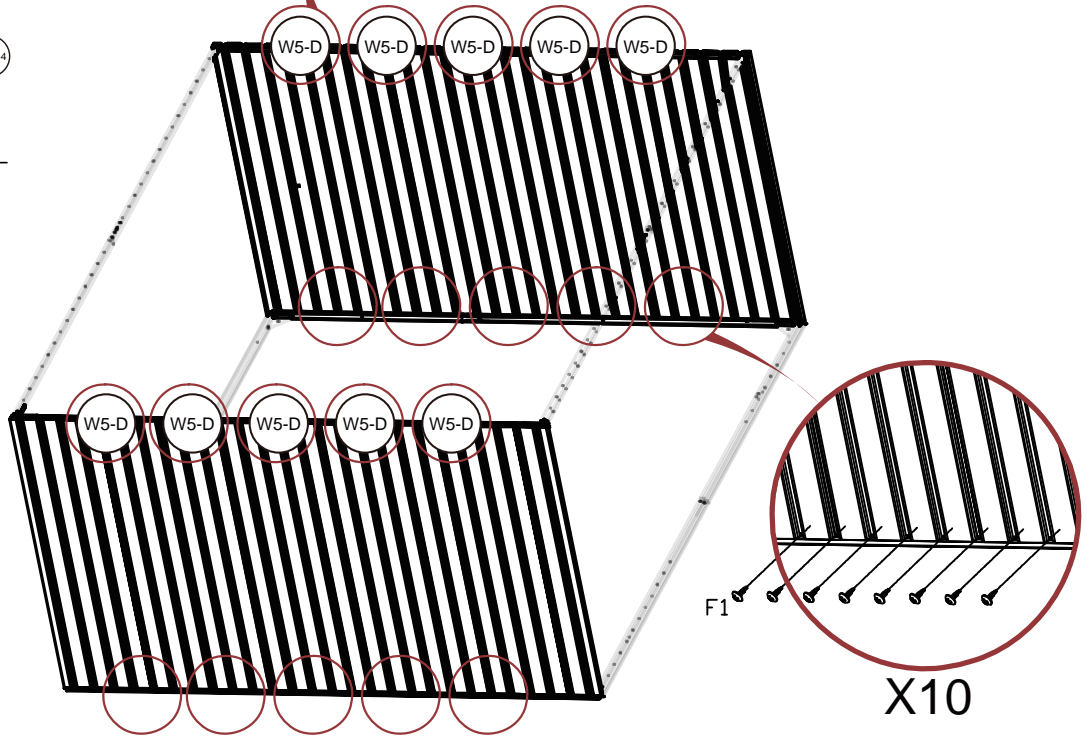
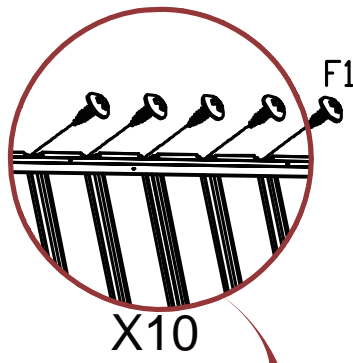
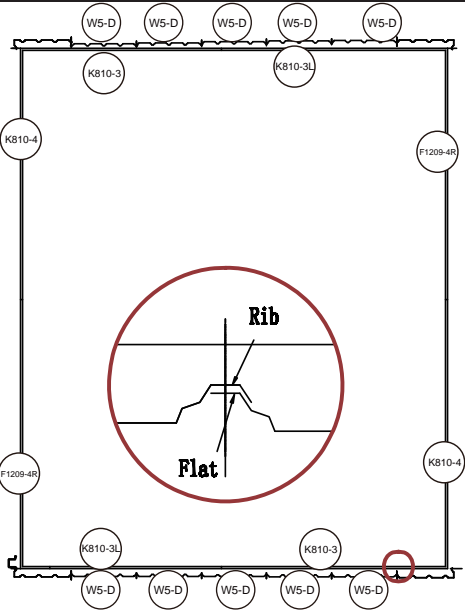

STEP 6

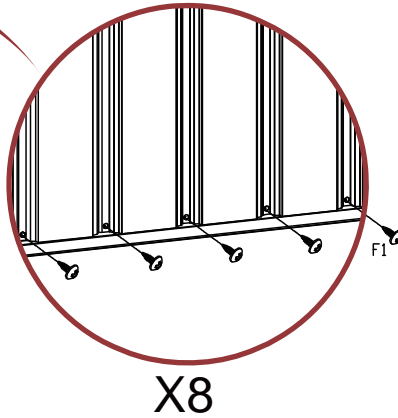
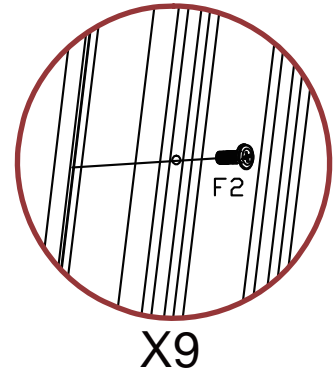
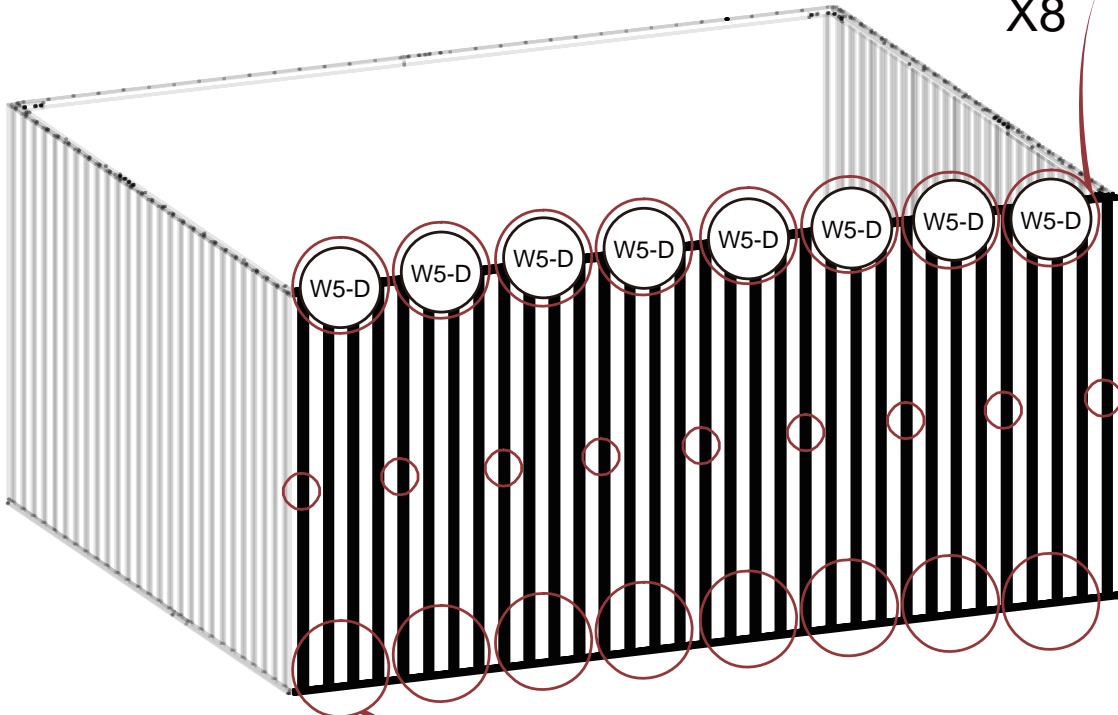
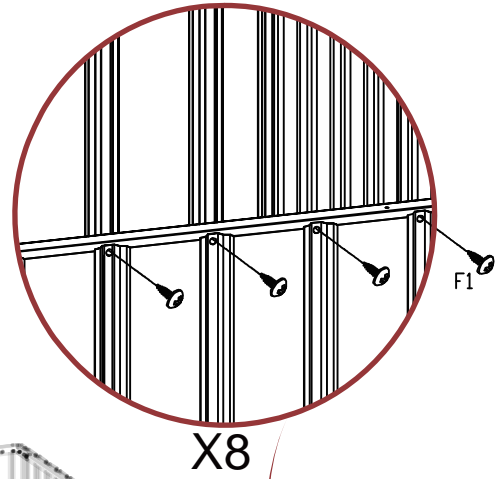
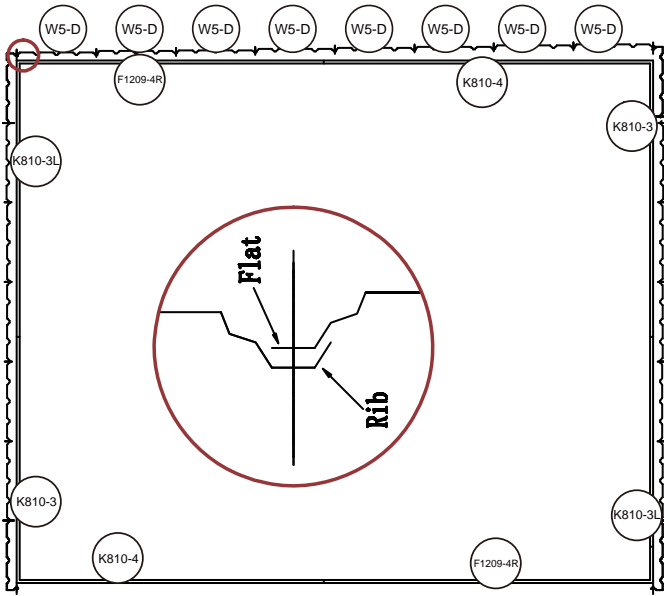

	F1	84
	F2	12

STEP 7



	F1	66
	F2	9

STEP 8

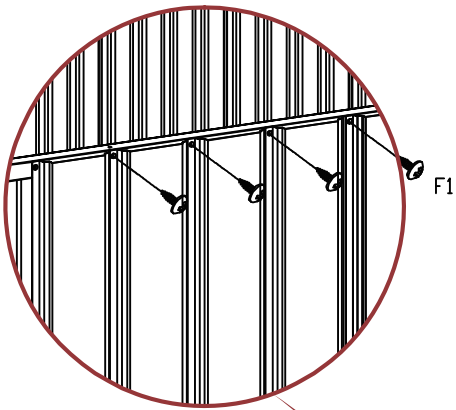
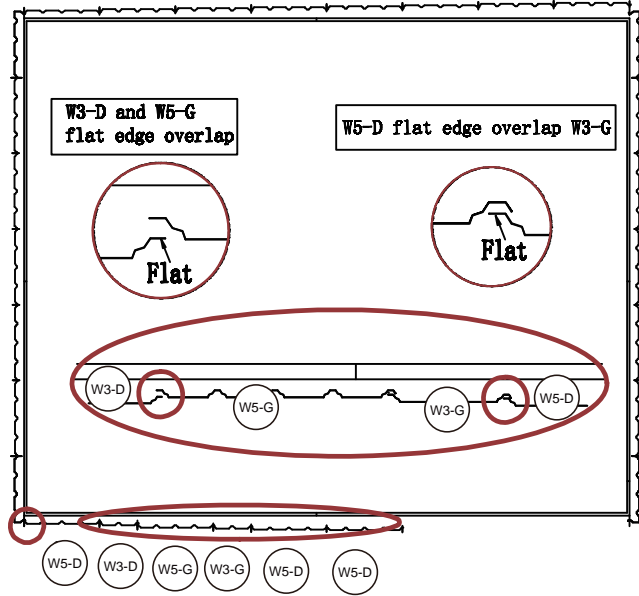

X2

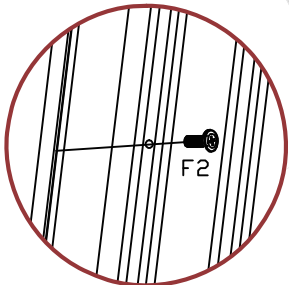
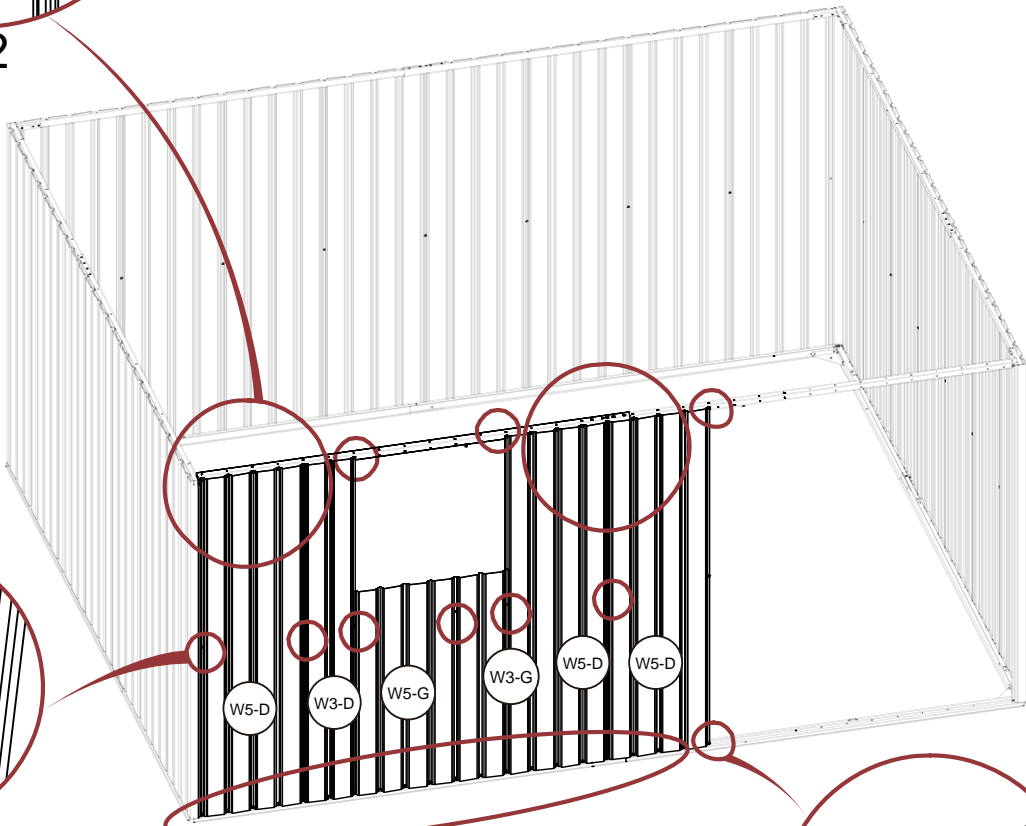
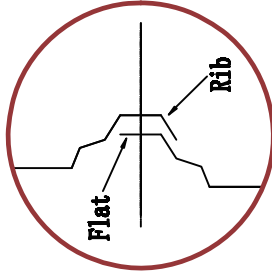

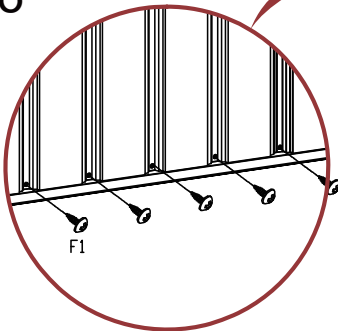

X6

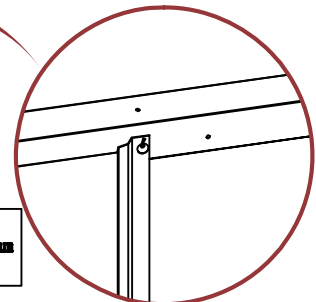

Do not add screws that indicated with an X in diagram These need to be left undone.



X4

	F1	33
	F2	6

STEP 9

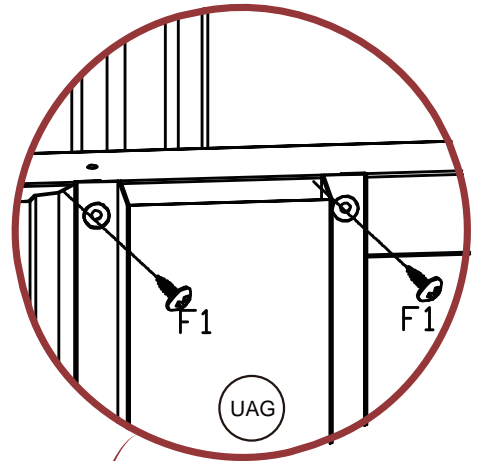
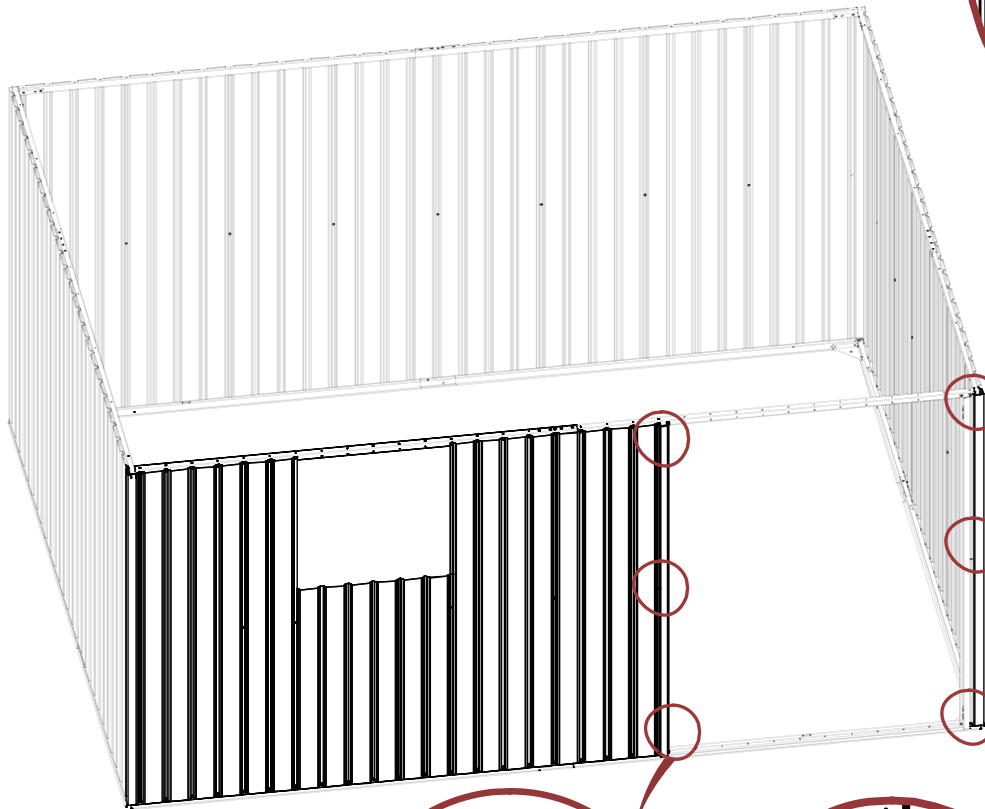
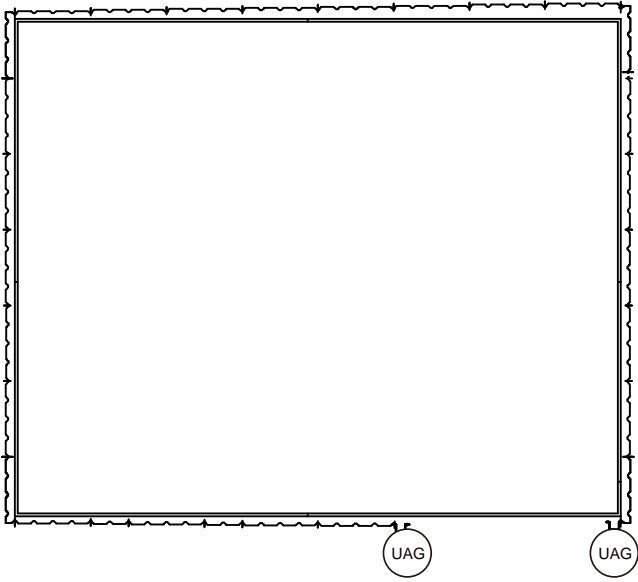

X2

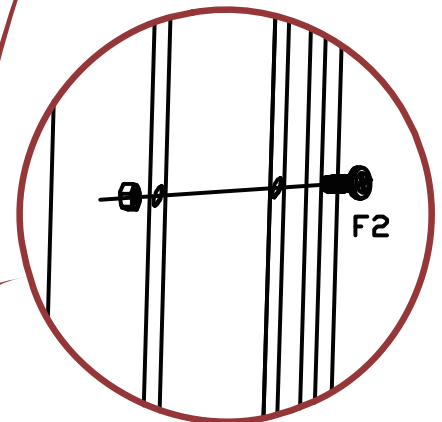

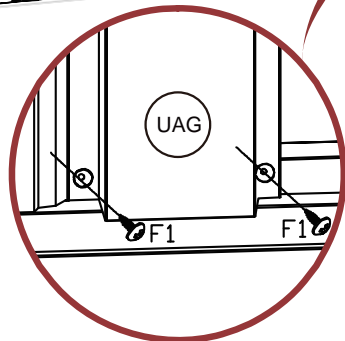

X2

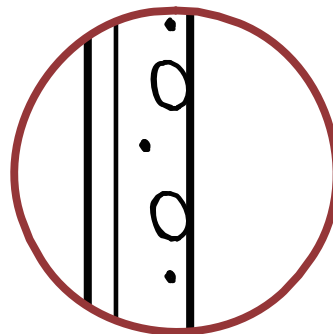

X2



The inner side is a hinge installation hole.

	F1	8
	F2	2

STEP 10

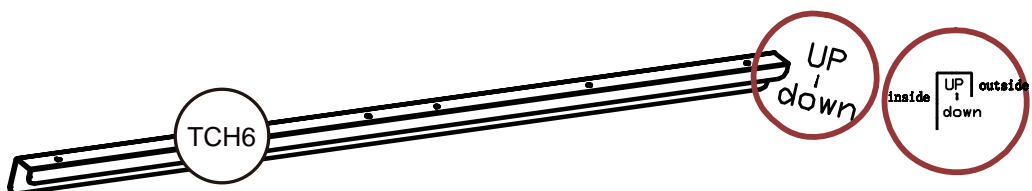
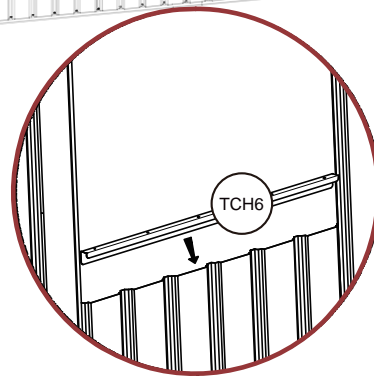
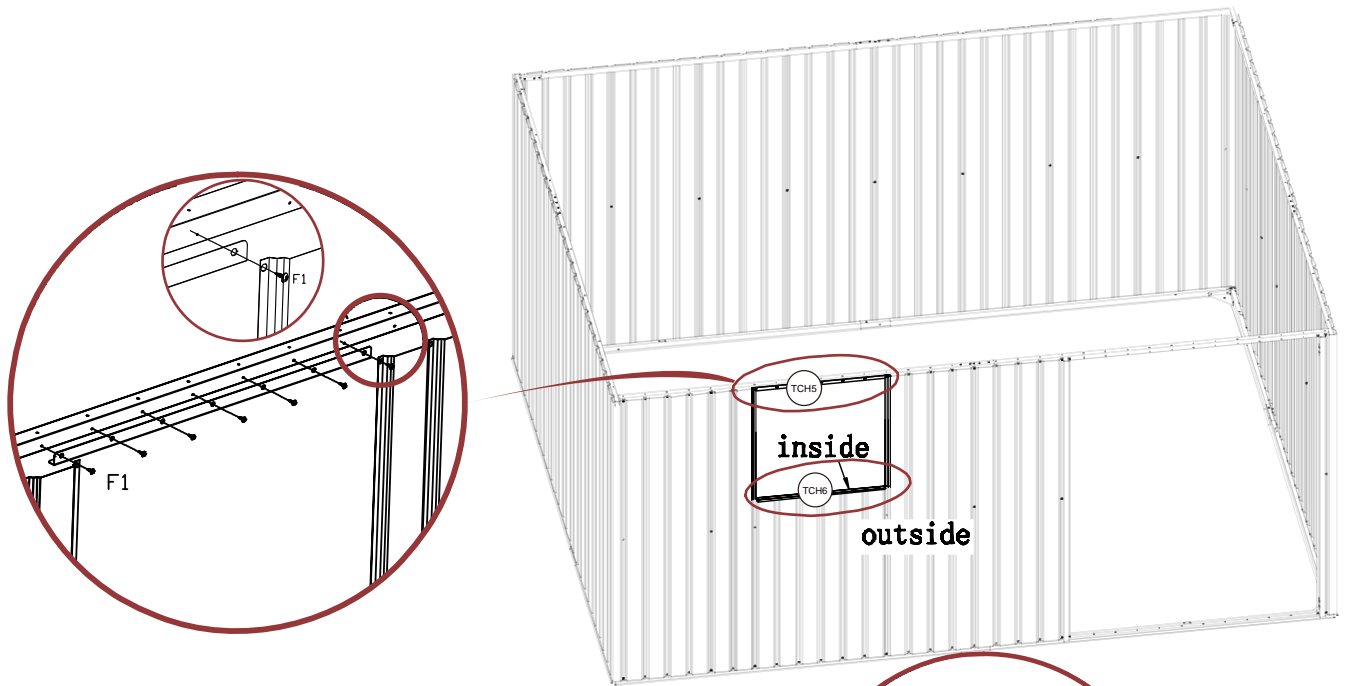
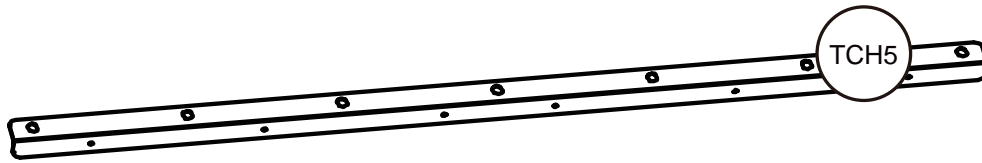

Installation method: Clip the TCH6 slot onto W5-F and W3-F, with the long side facing inward, without the need for screws to secure.

STEP 11

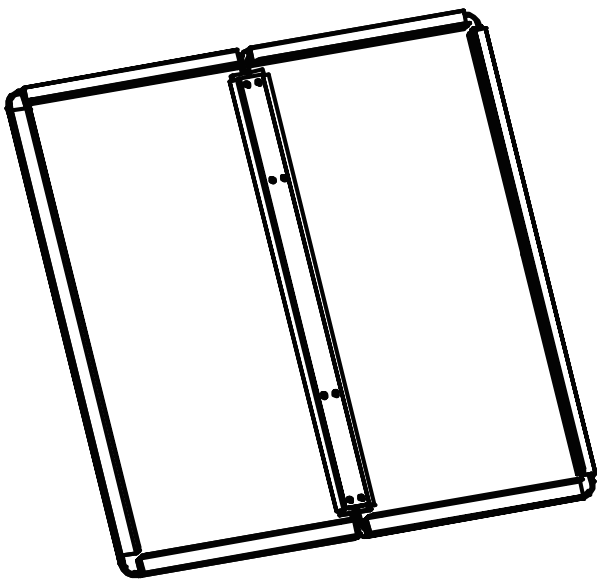
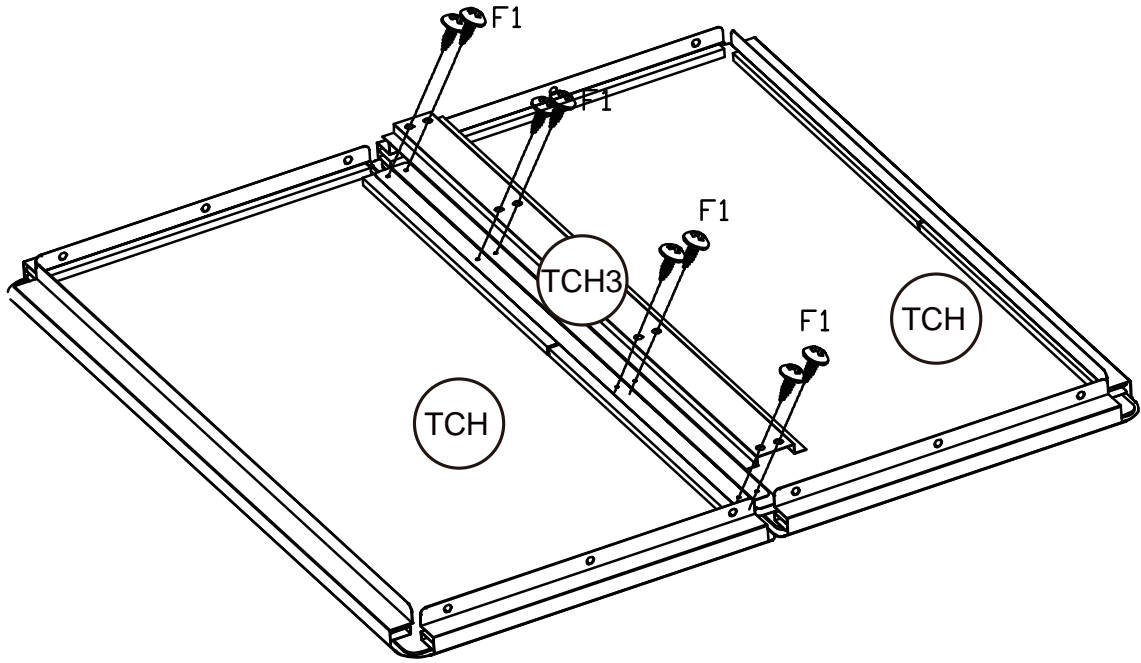

back

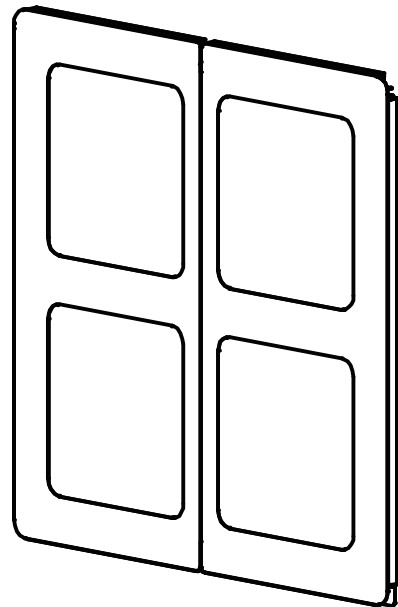

positive

	F1	8
---	----	---

STEP 12

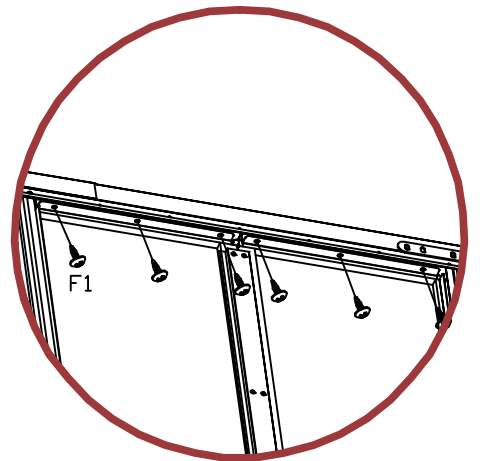
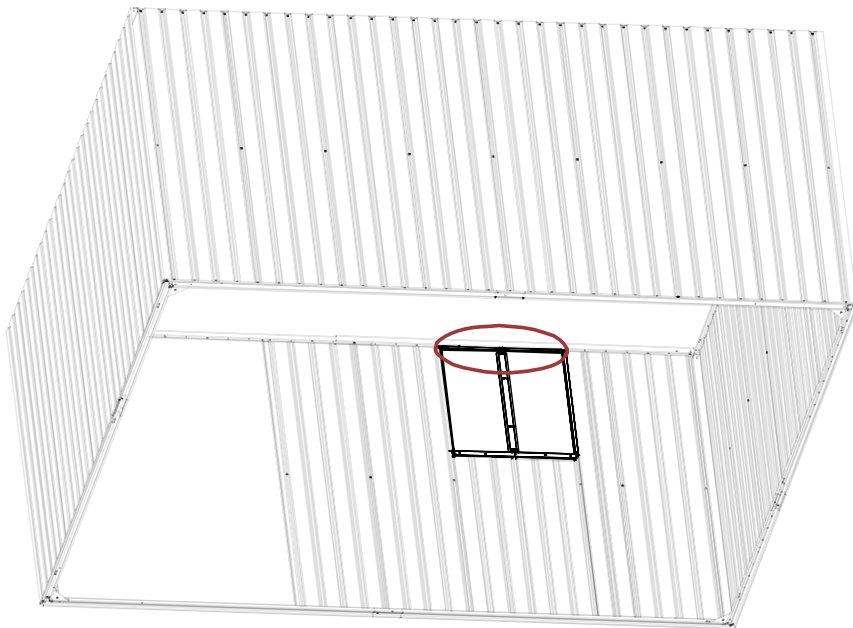
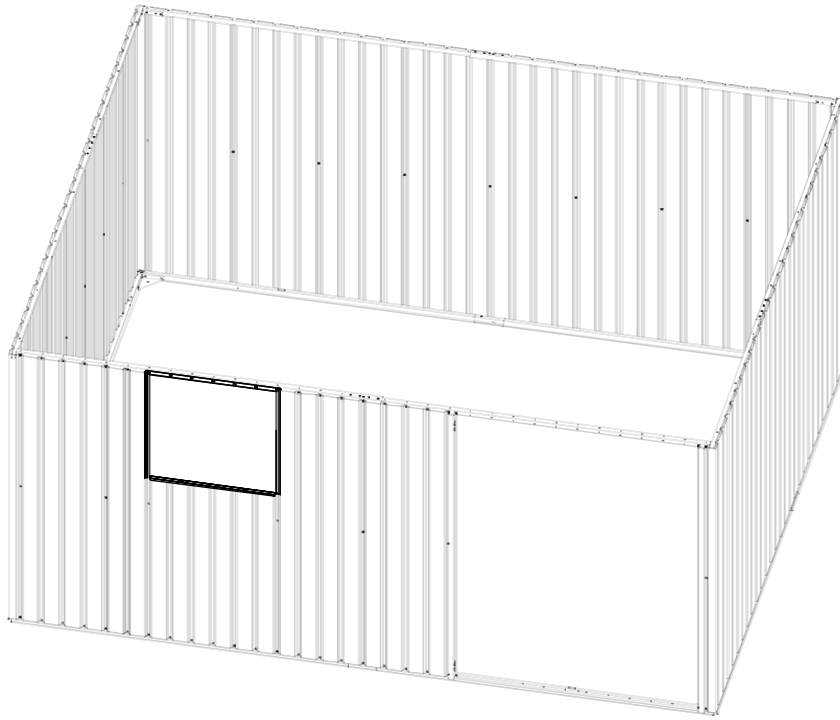
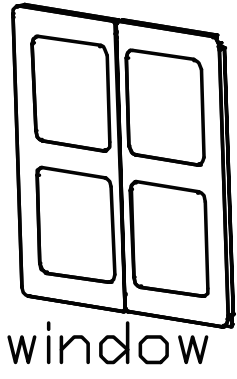

	F1	6
---	----	---

STEP 13

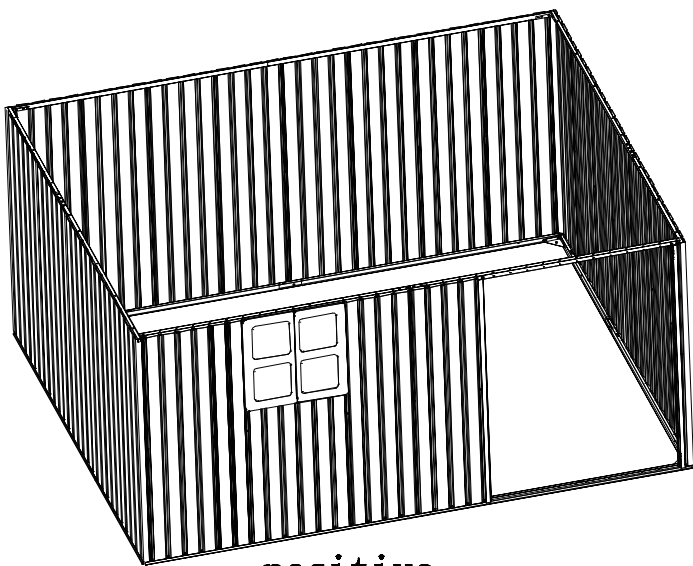
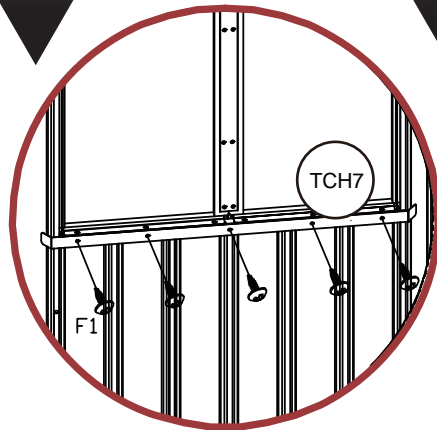
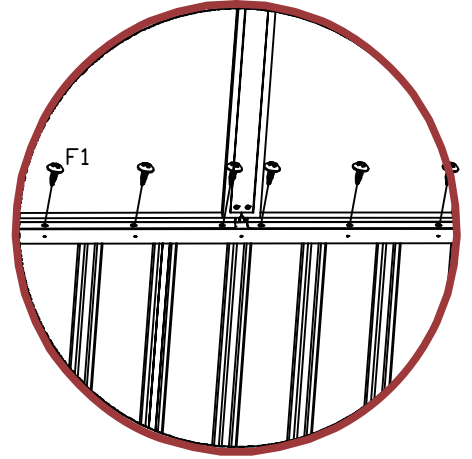
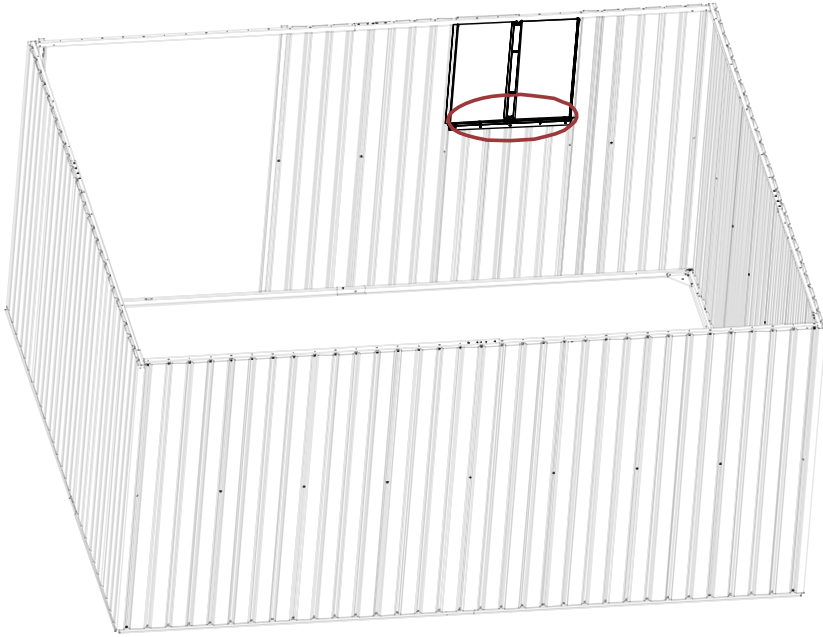

positive

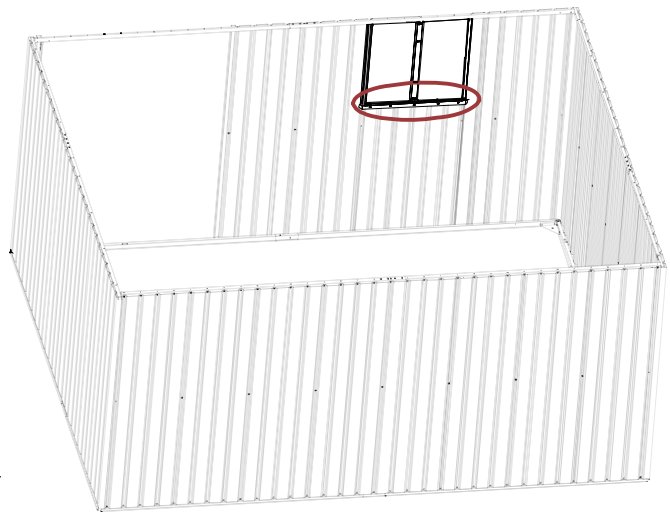

back

	F1	11
---	----	----

STEP 14

Attention: Assemble the ventilation board screws in the order shown in the diagram, Install the middle hole first to avoid misalignment.

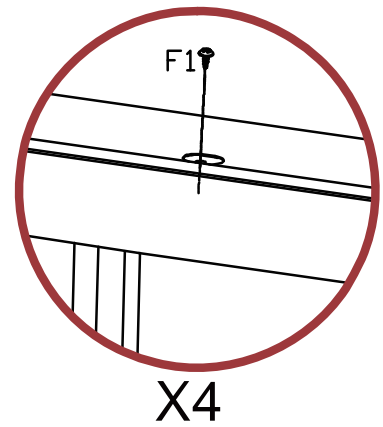
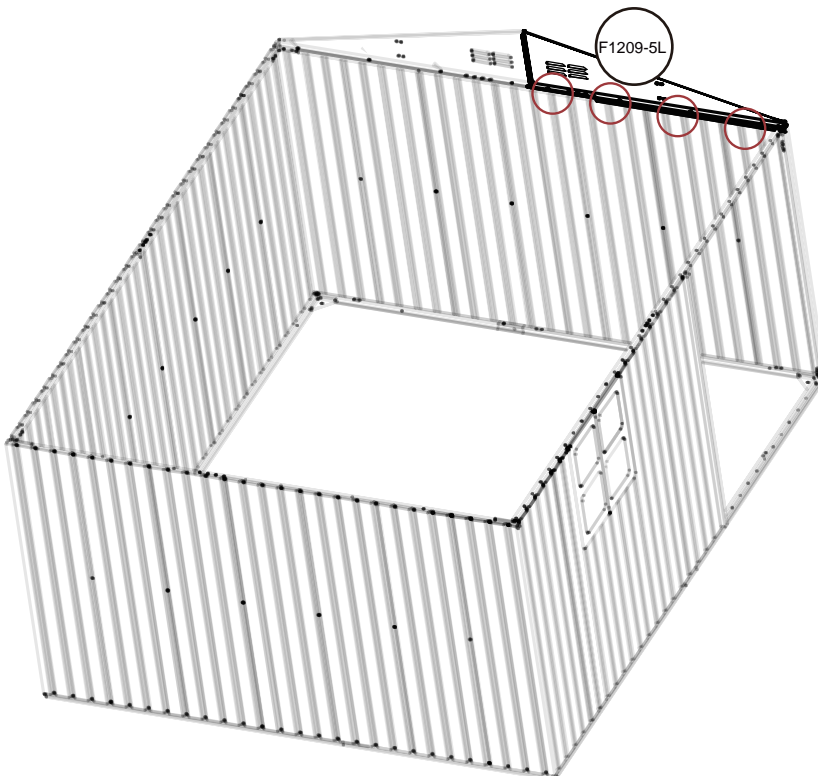
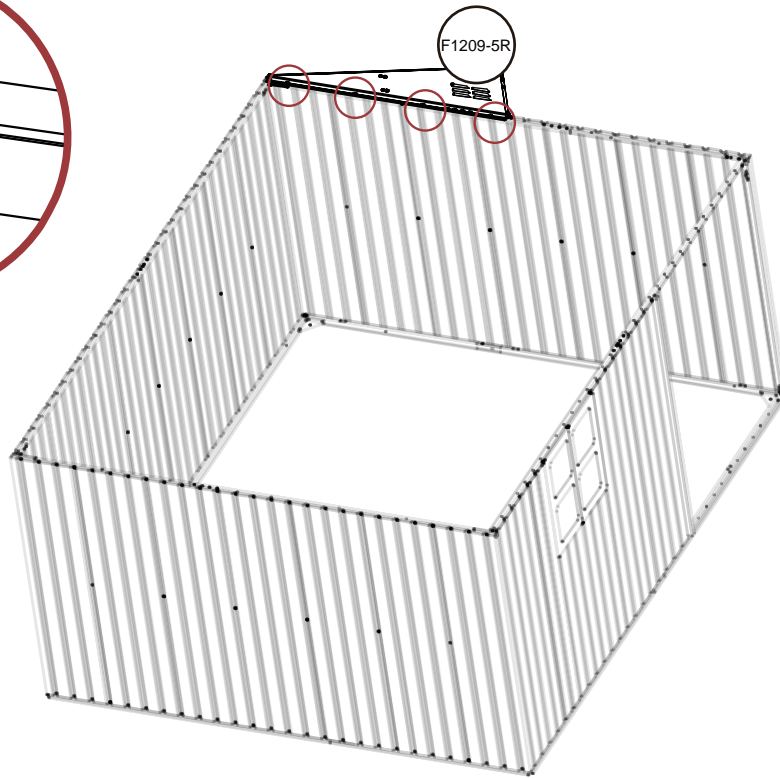
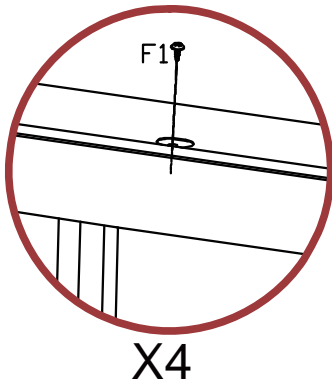

	F1	8
---	----	---

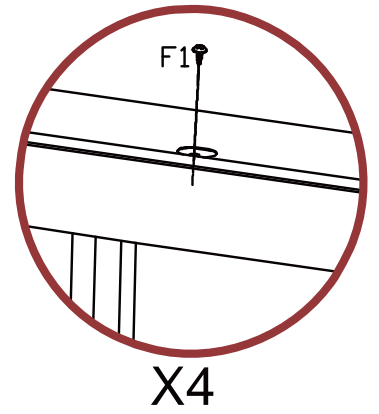
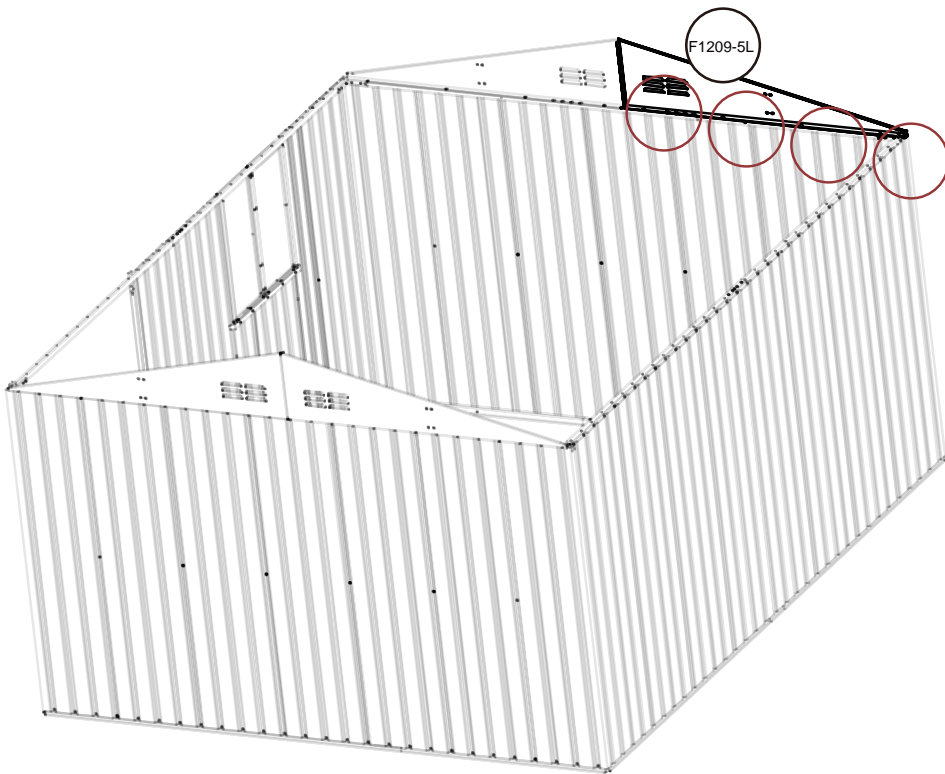
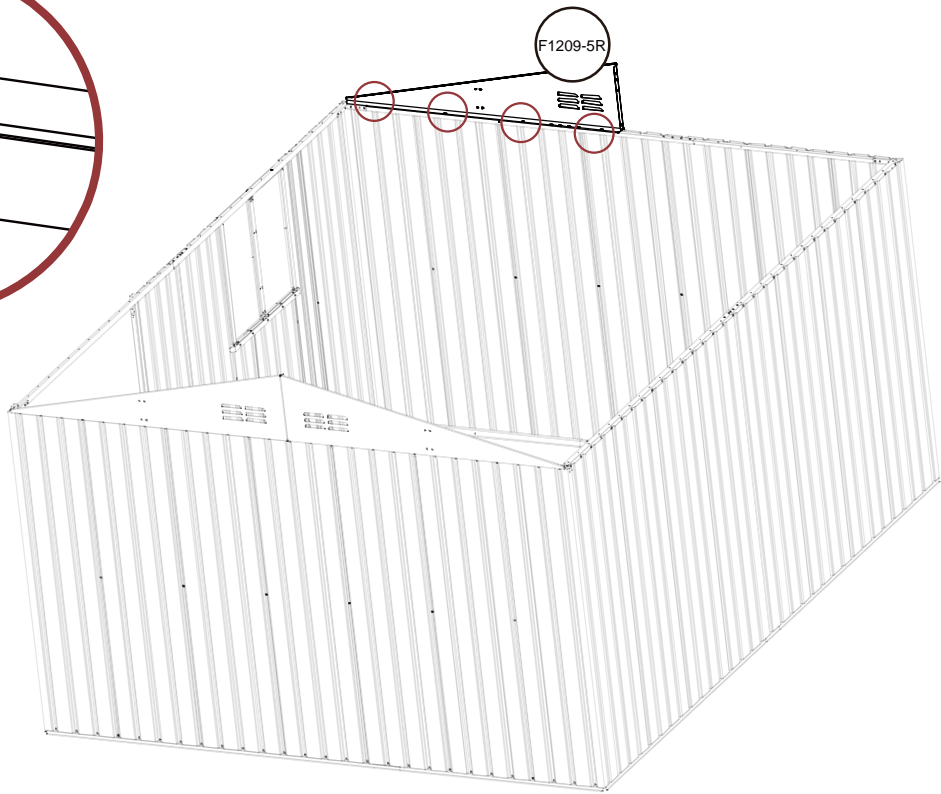
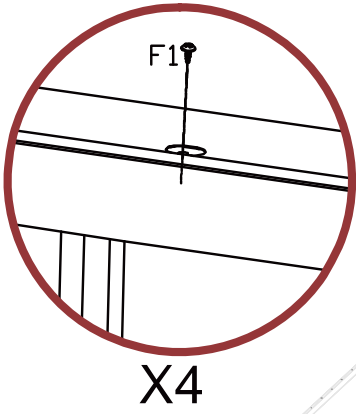

STEP 15

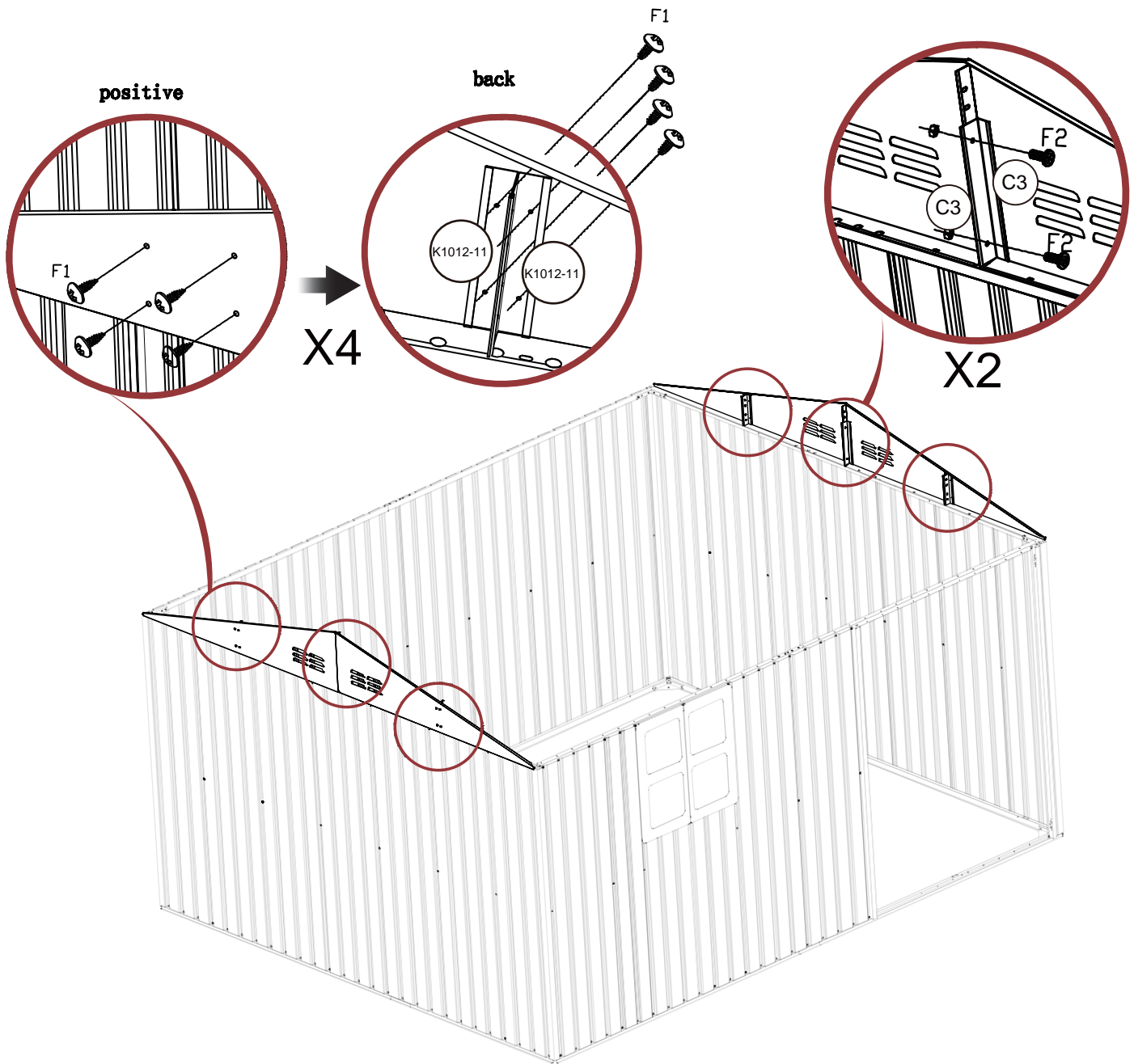

	F1	8
---	----	---

STEP 16



	F1	16
	F2	4

STEP 17

X3

K812-6M has a smaller width and can be fitted into K812-6L. Align the holes with K812-6R.

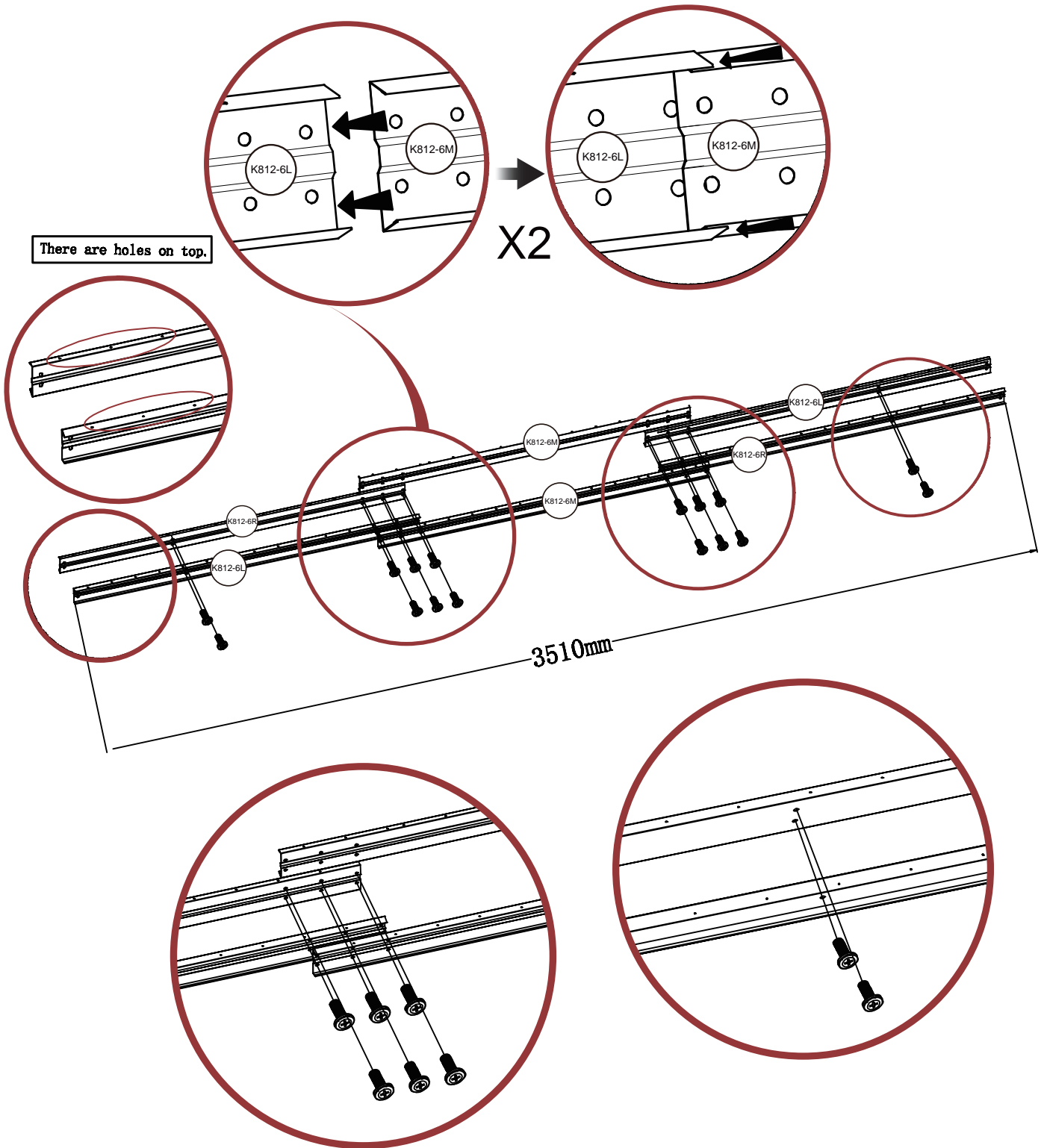

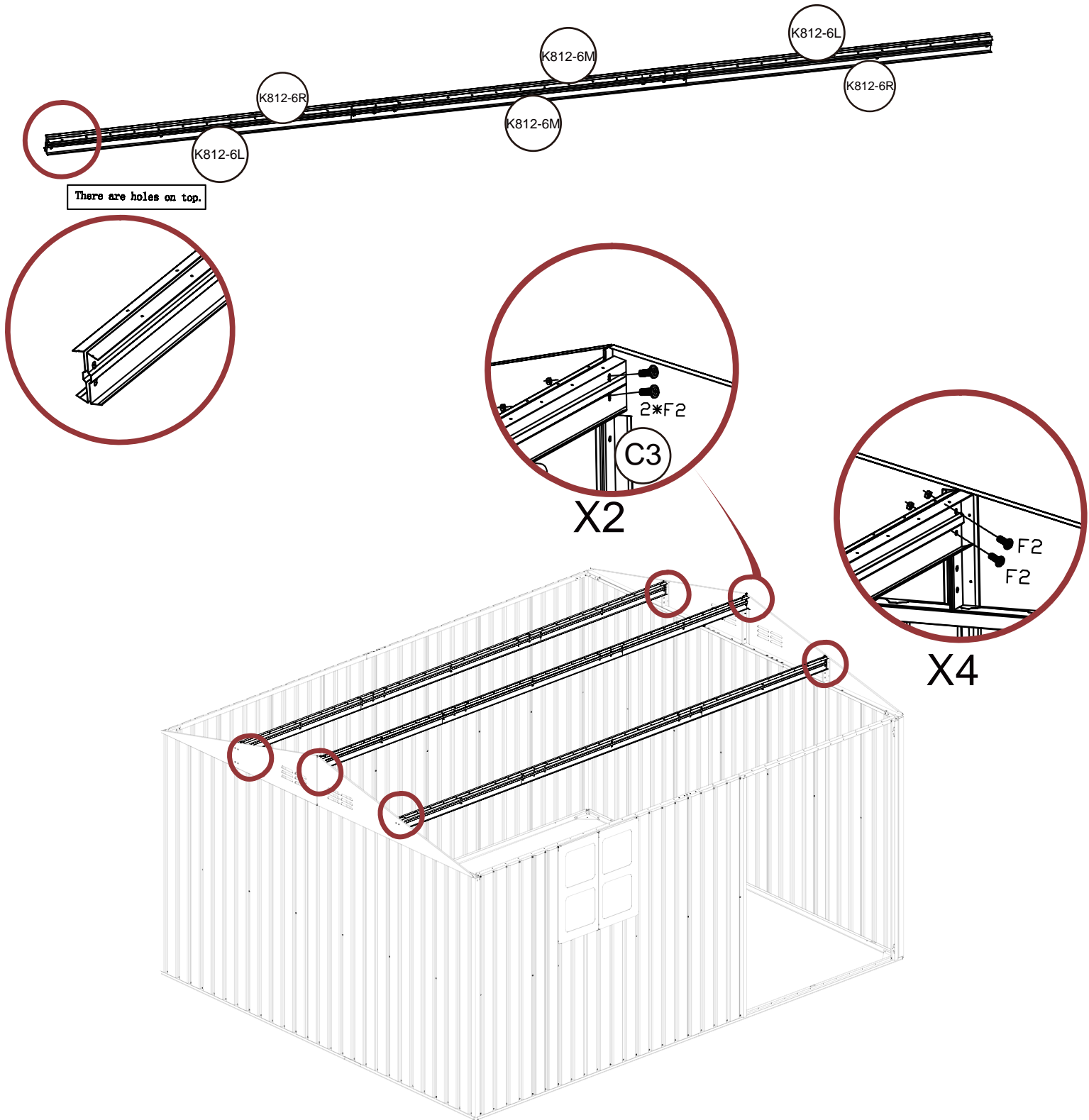

STEP 18

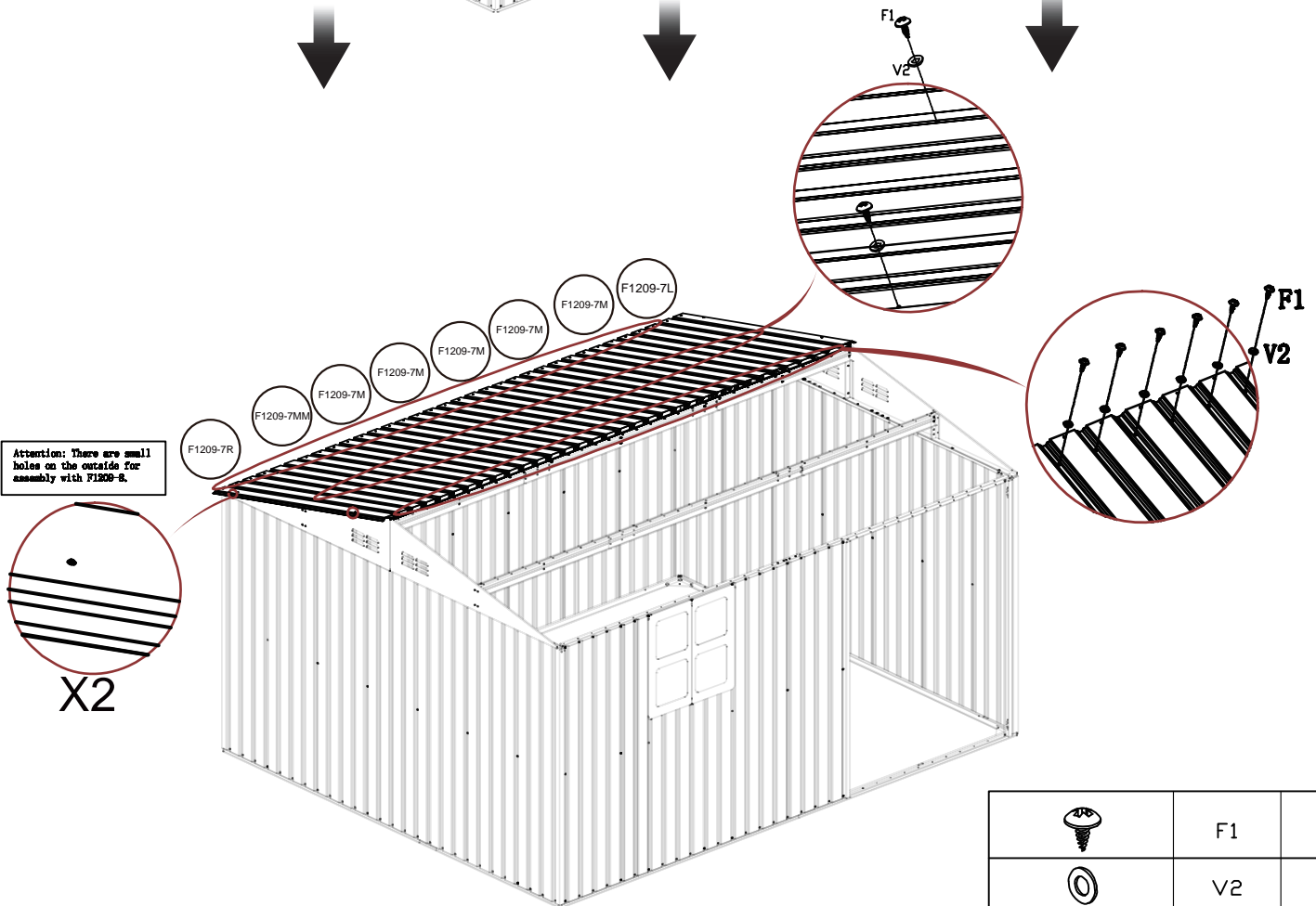
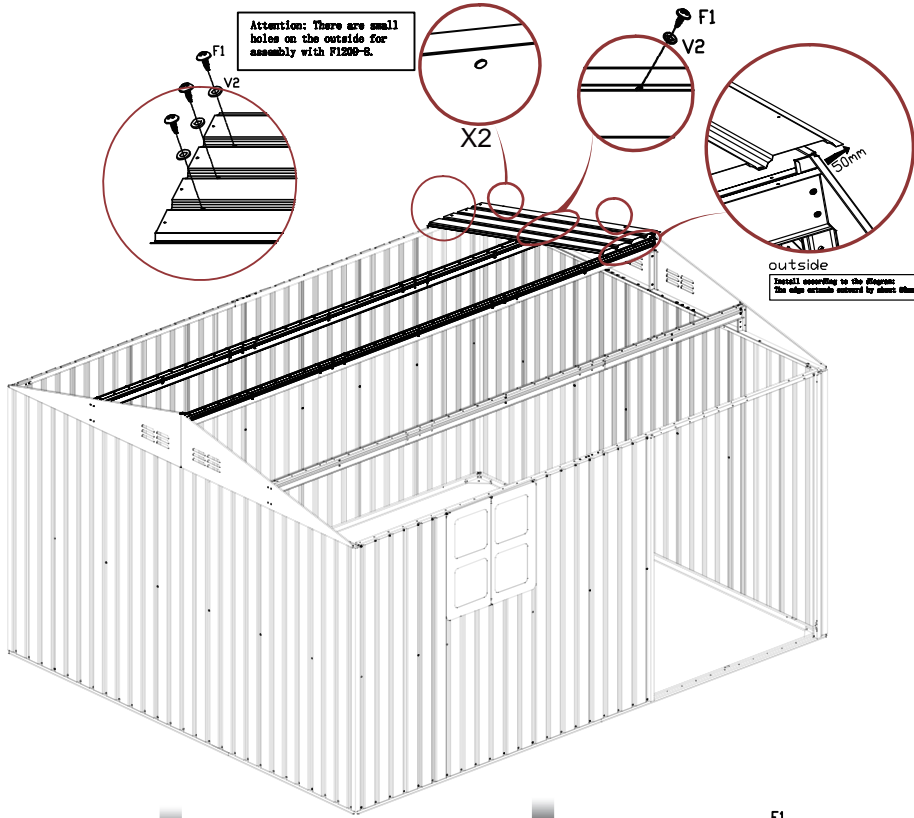
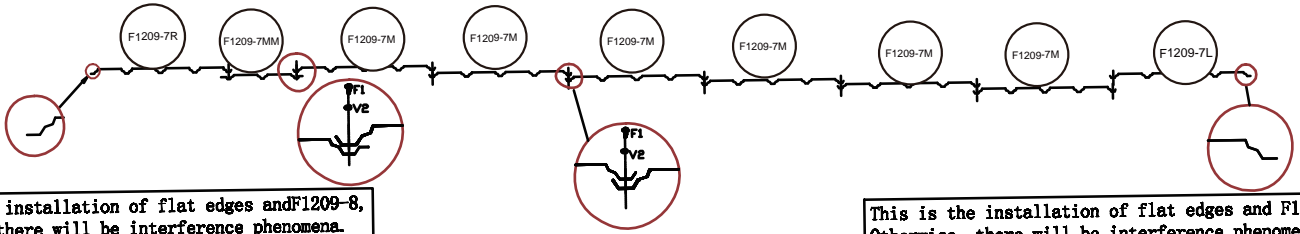

	F2	12
---	----	----

STEP 19



	F1	74
	V2	74

STEP 20

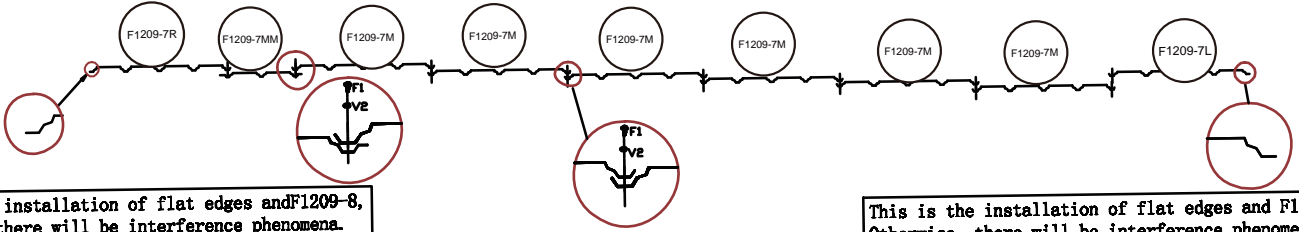

This is the installation of flat edges and F1209-8, Otherwise, there will be interference phenomena.

This is the installation of flat edges and F1209-8, Otherwise, there will be interference phenomena.

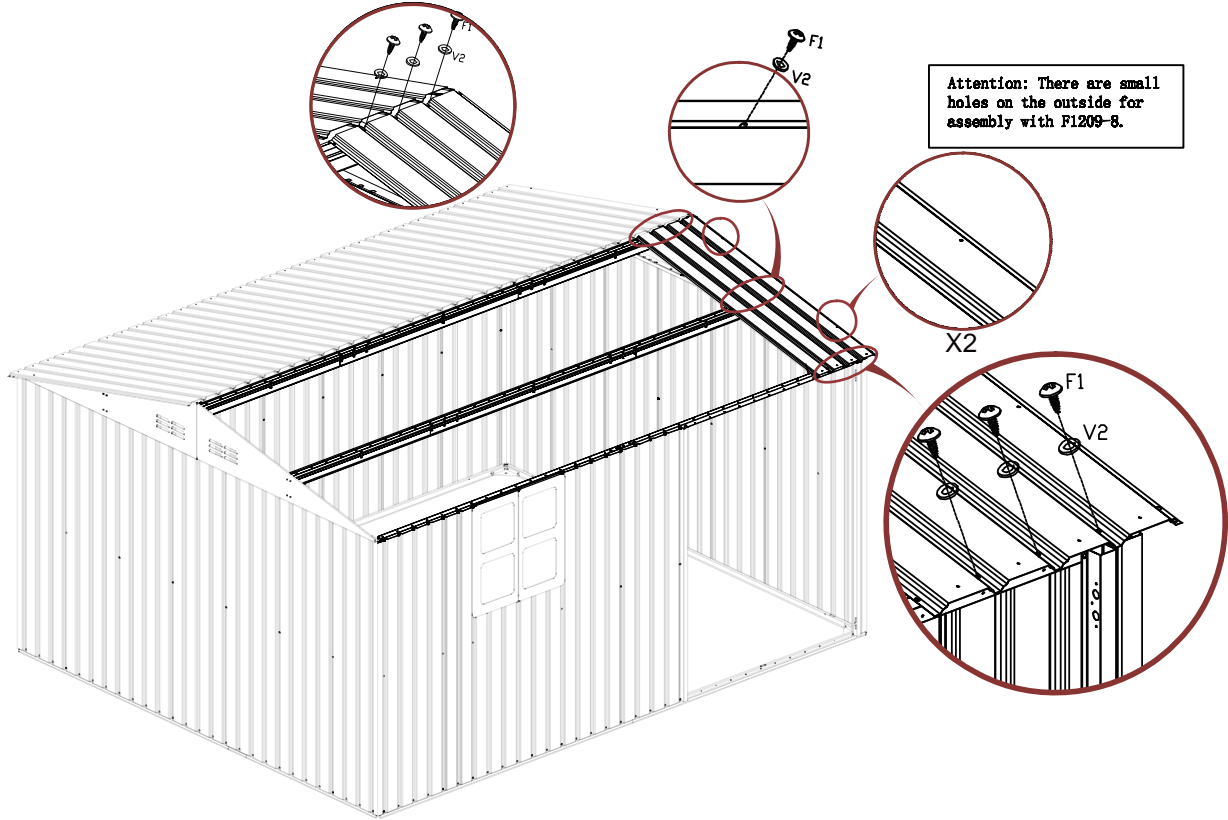



Attention: There are small holes on the outside for assembly with F1209-8.

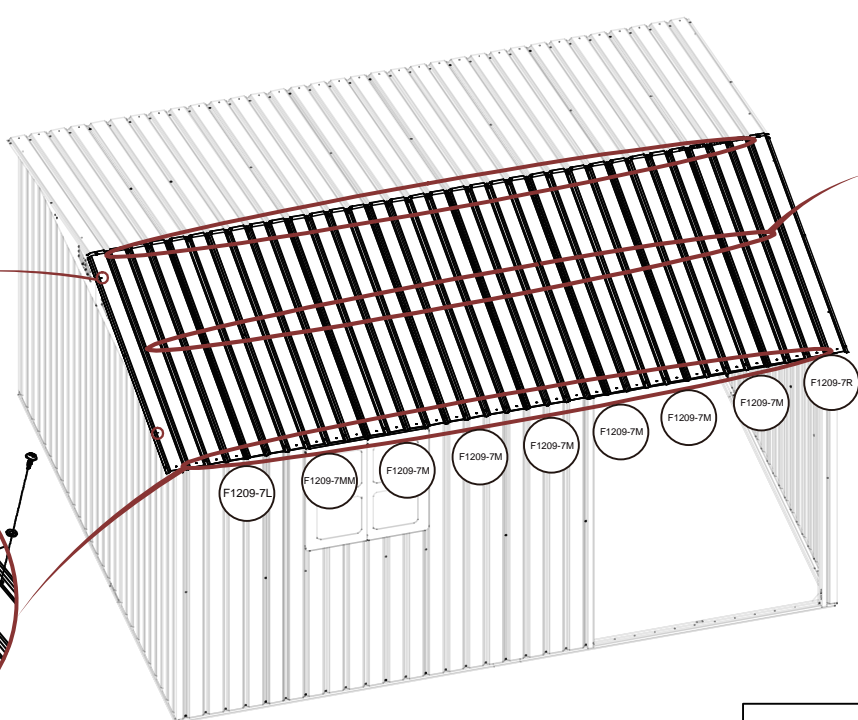
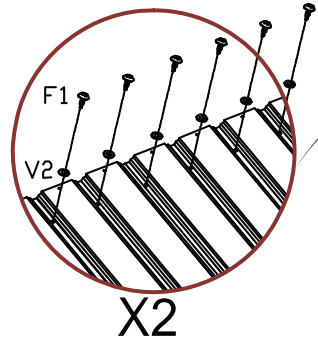
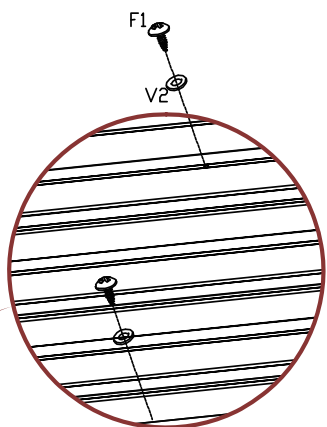
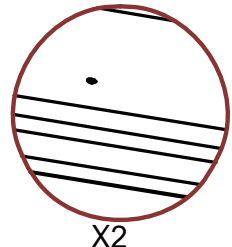

Attention: There are small holes on the outside for assembly with F1209-8.



	F1	74
	V2	74

STEP 21

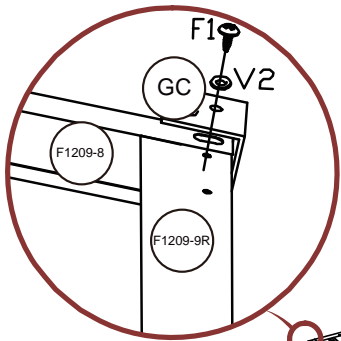
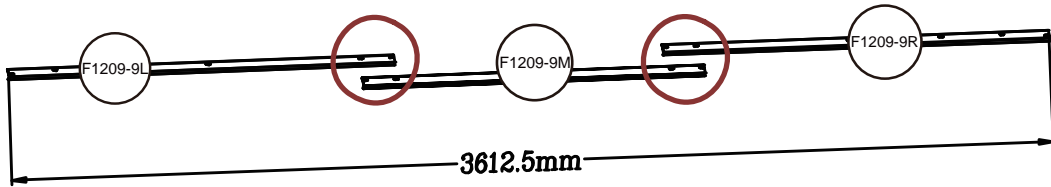
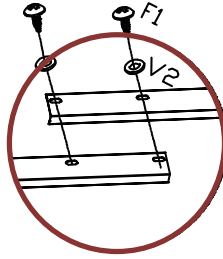
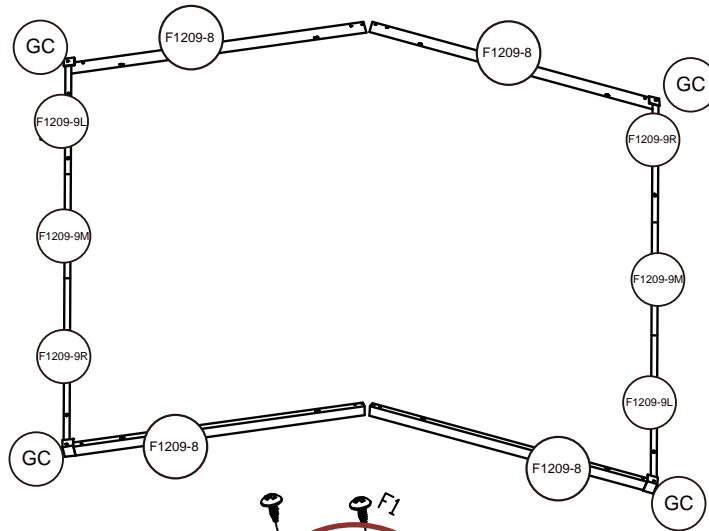

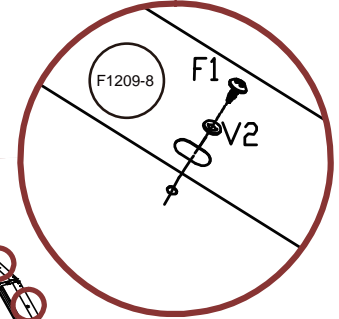

X4



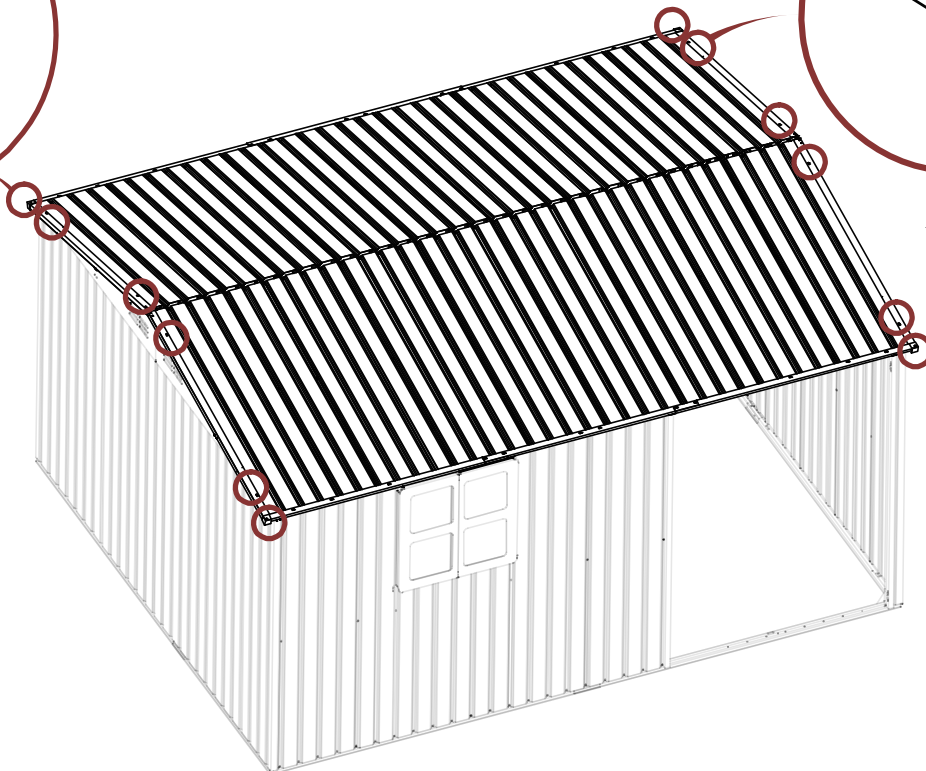

X8



	F1	36
	V2	36

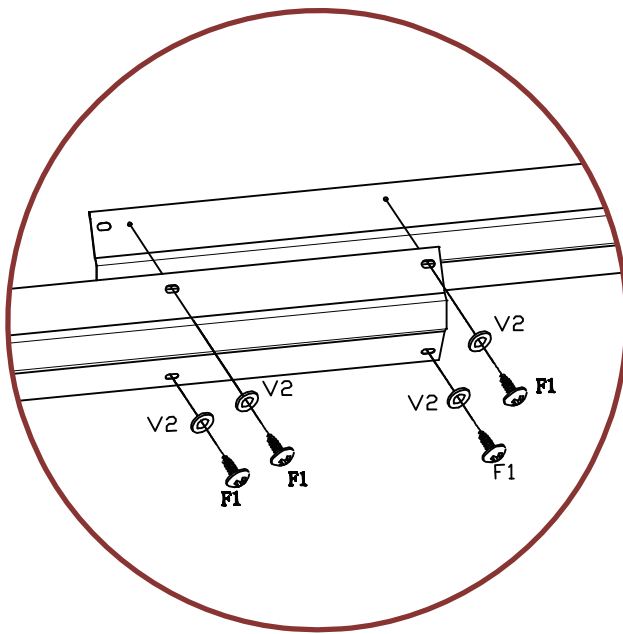
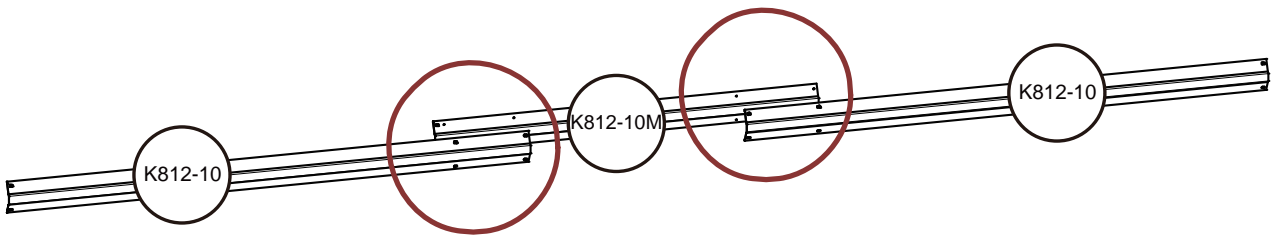
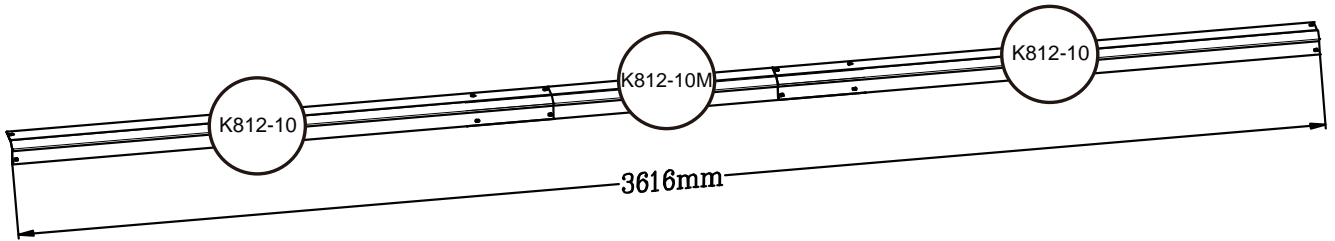

STEP 22

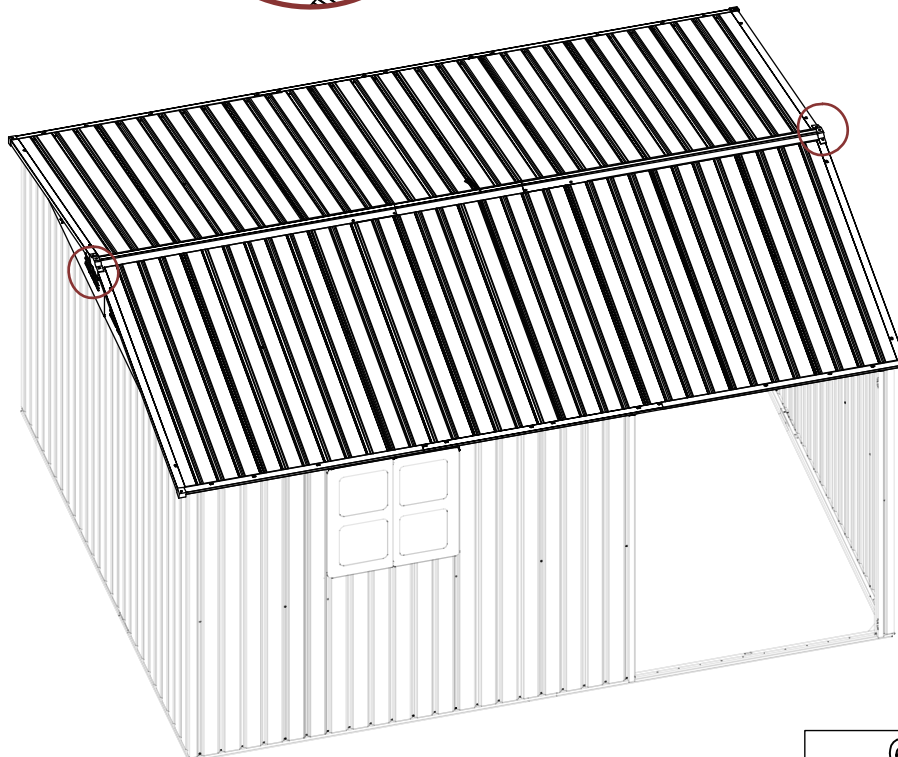
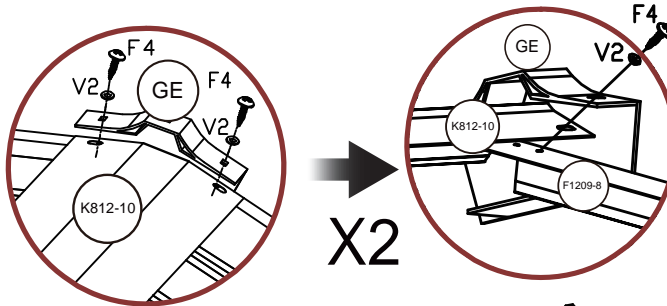
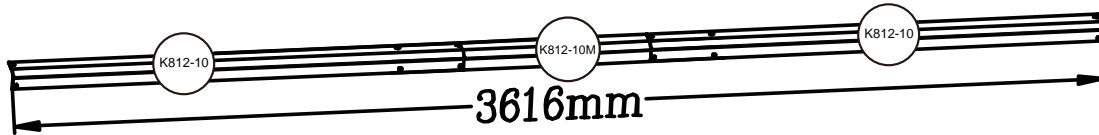
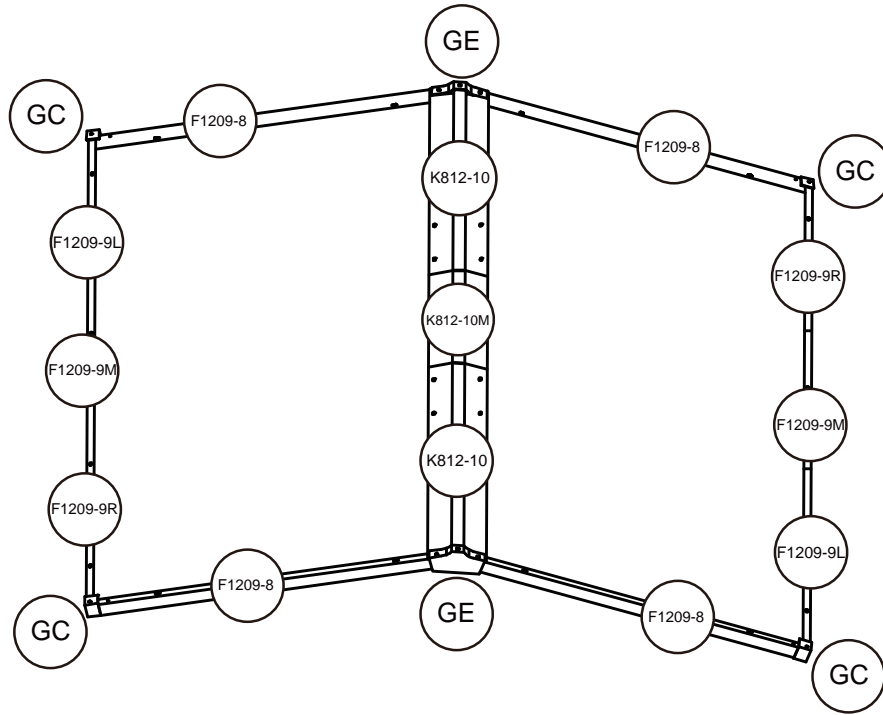

	F1	8
	V2	8

STEP 23



	V2	4
	F4	4

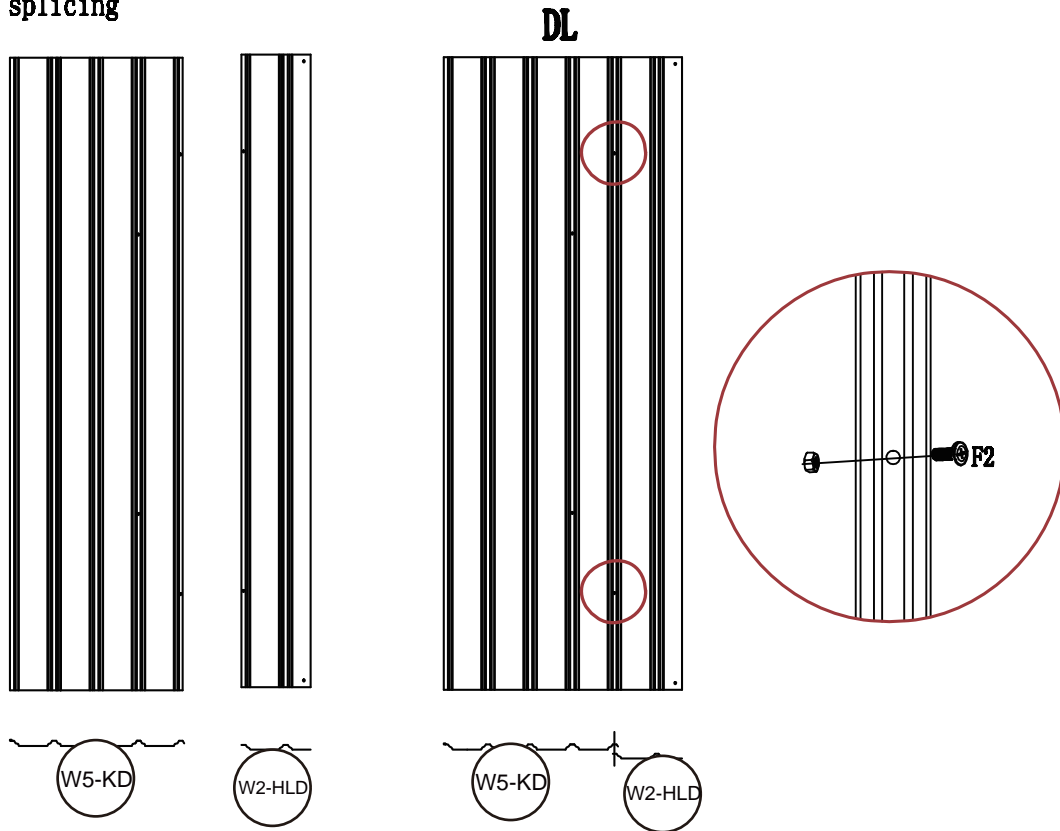

STEP 24

Left door panel splicing



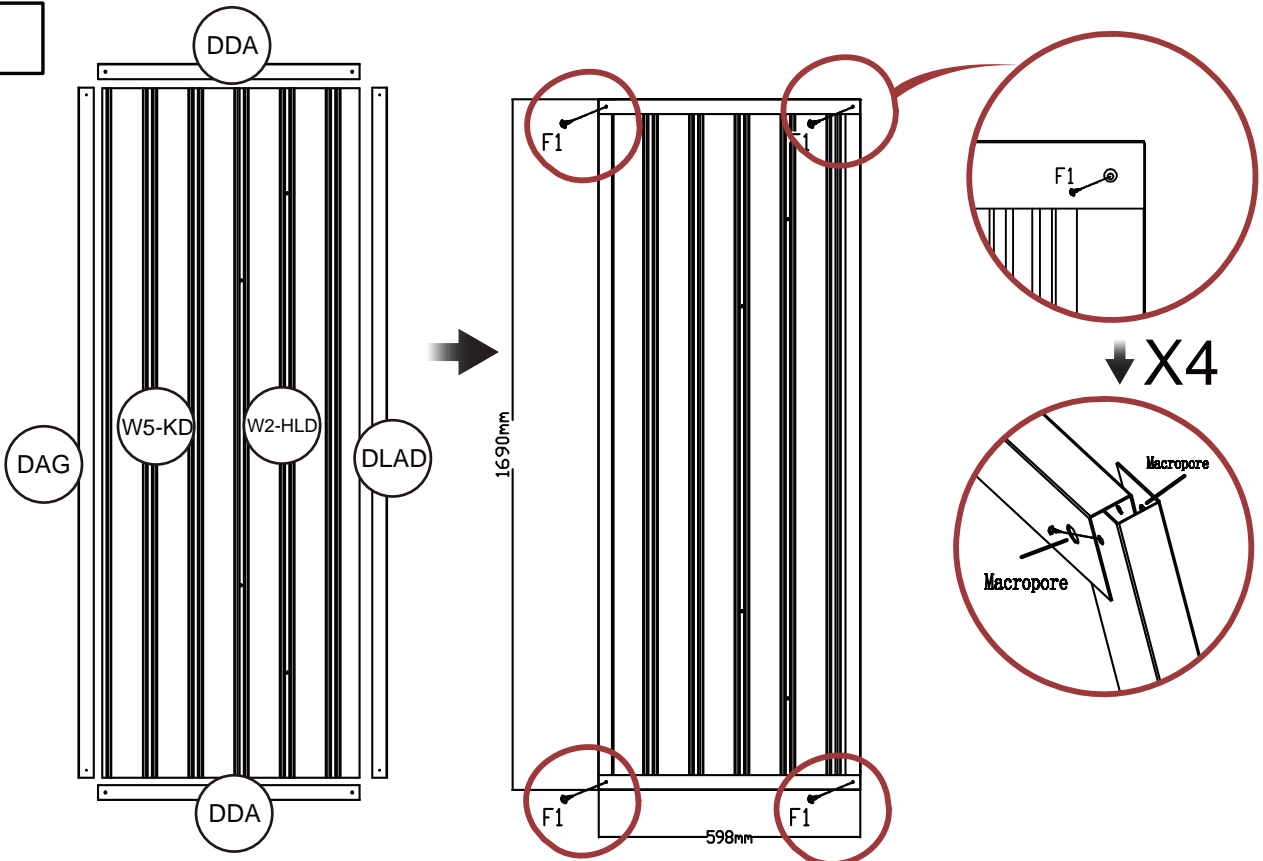

positive

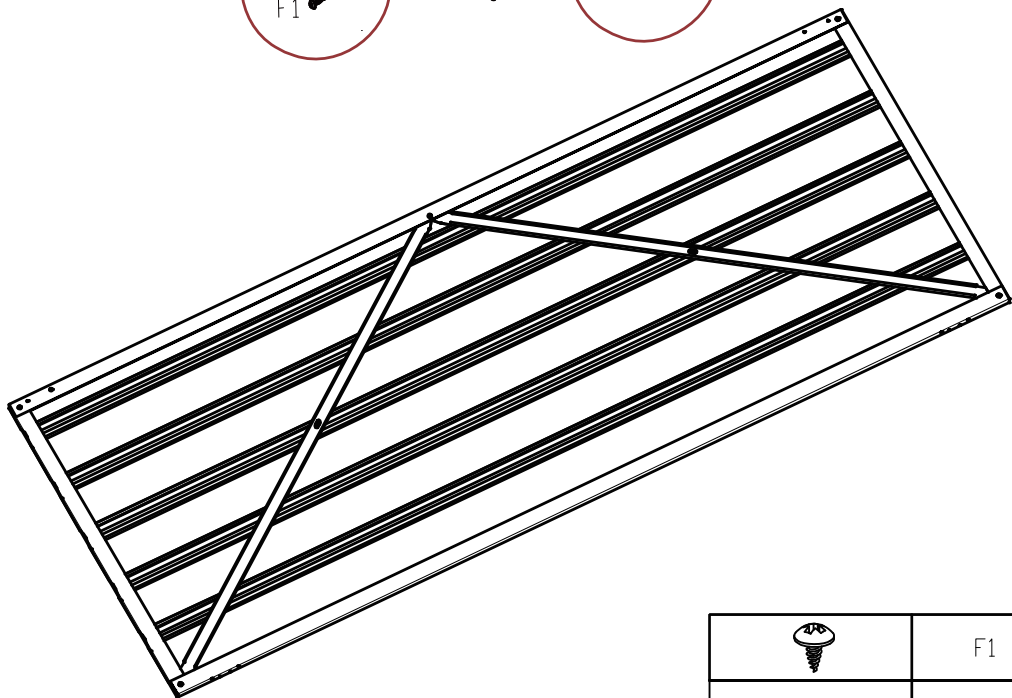
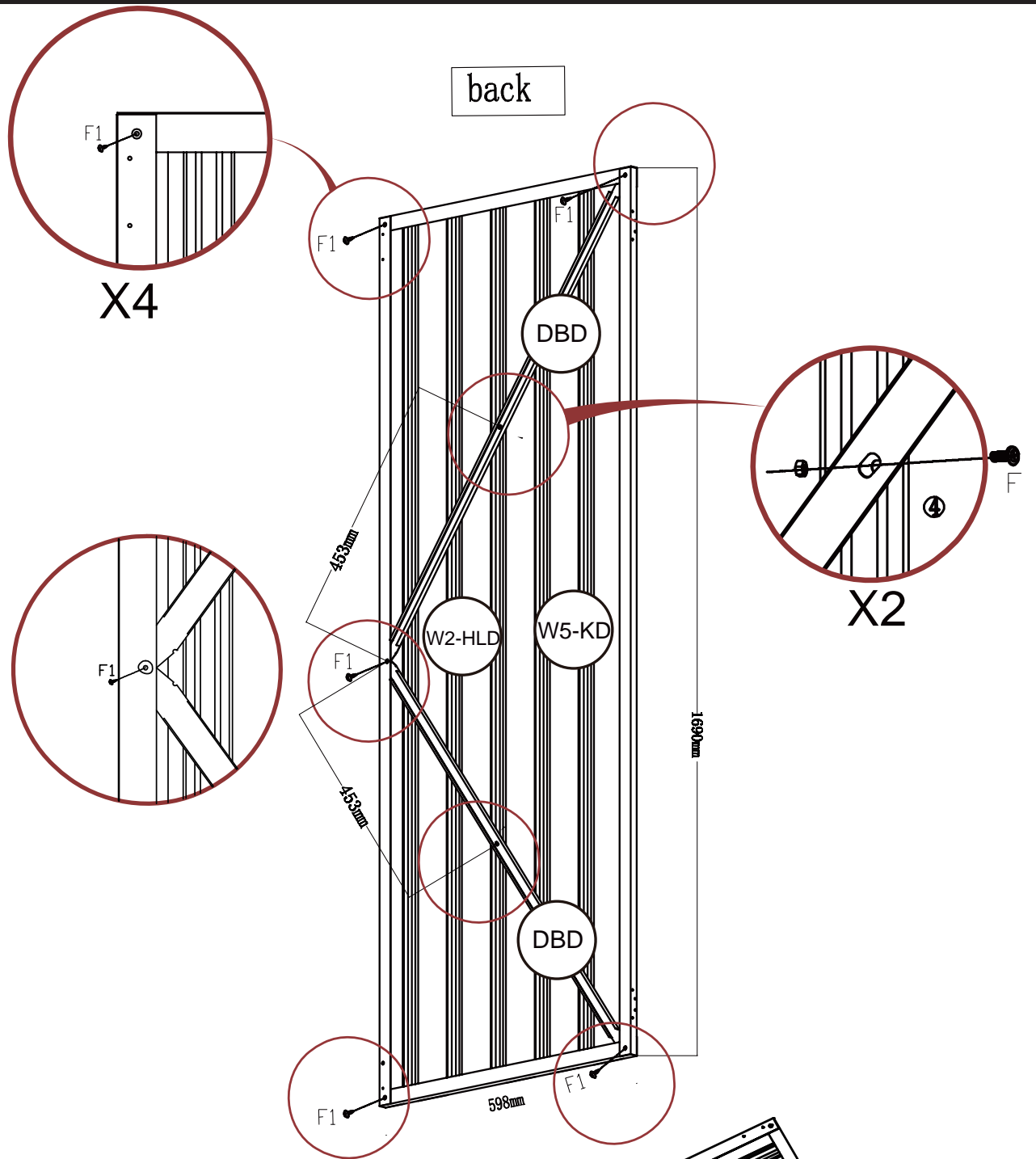

	F1	4
	F2	2

STEP 25



	F1	5
	F2	2

STEP 26

DR

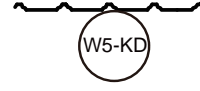
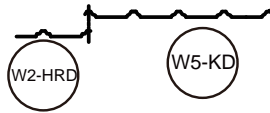
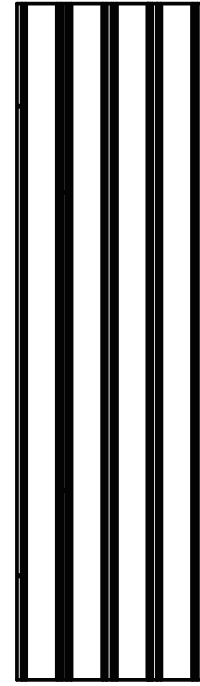
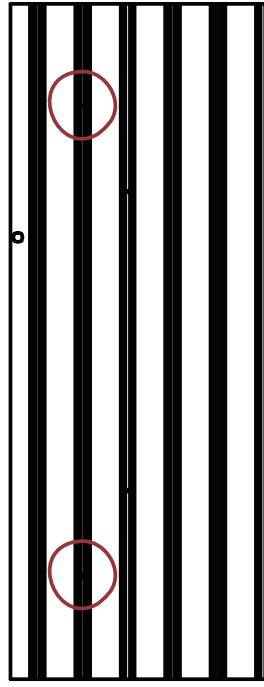
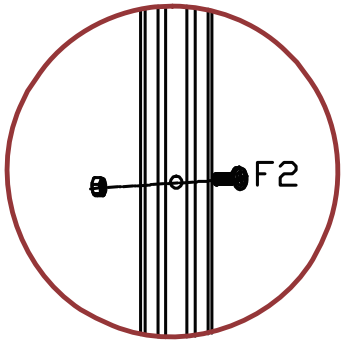

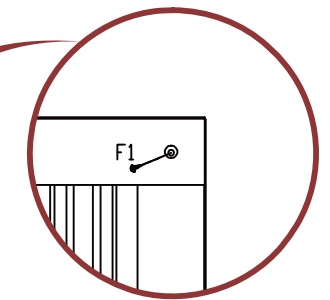
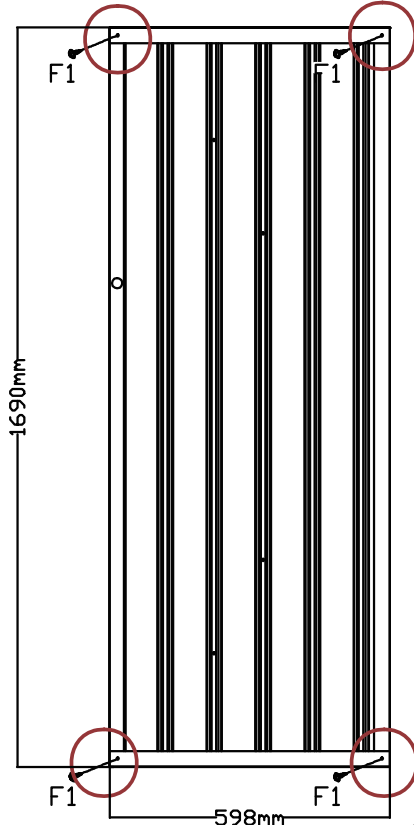
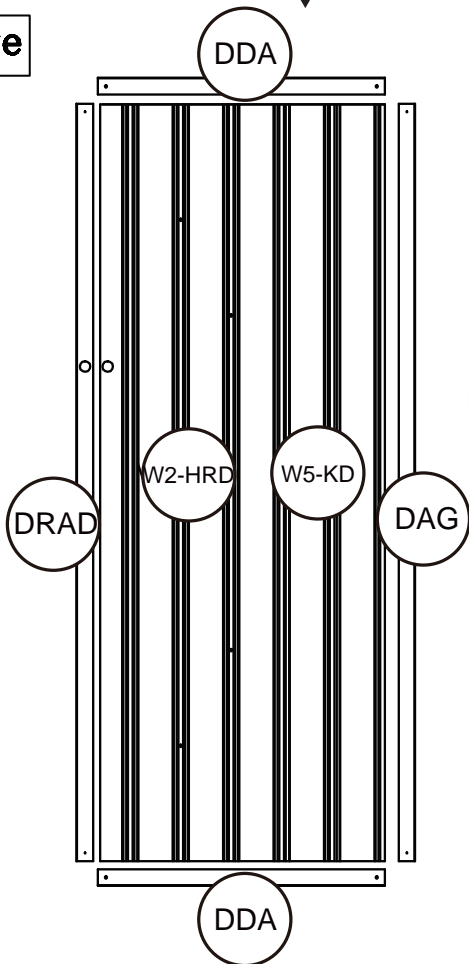

positive

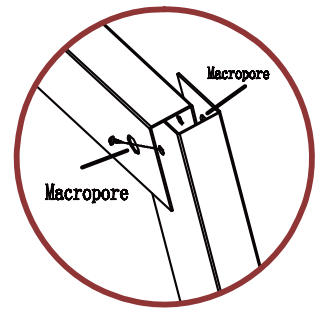

X4



	F1	4
	F2	2

STEP 27

Right door panel splicing

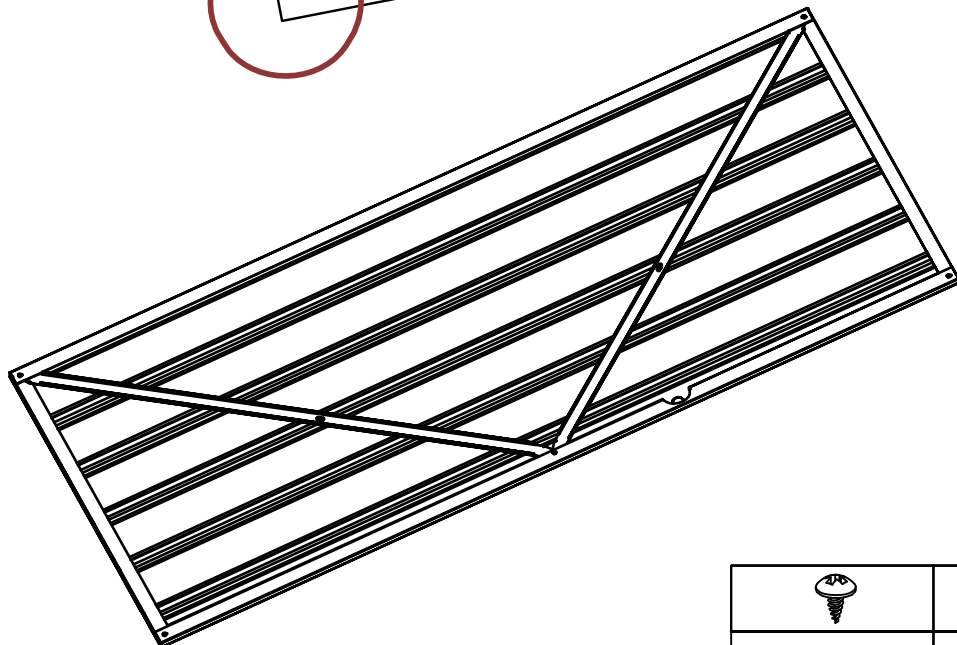
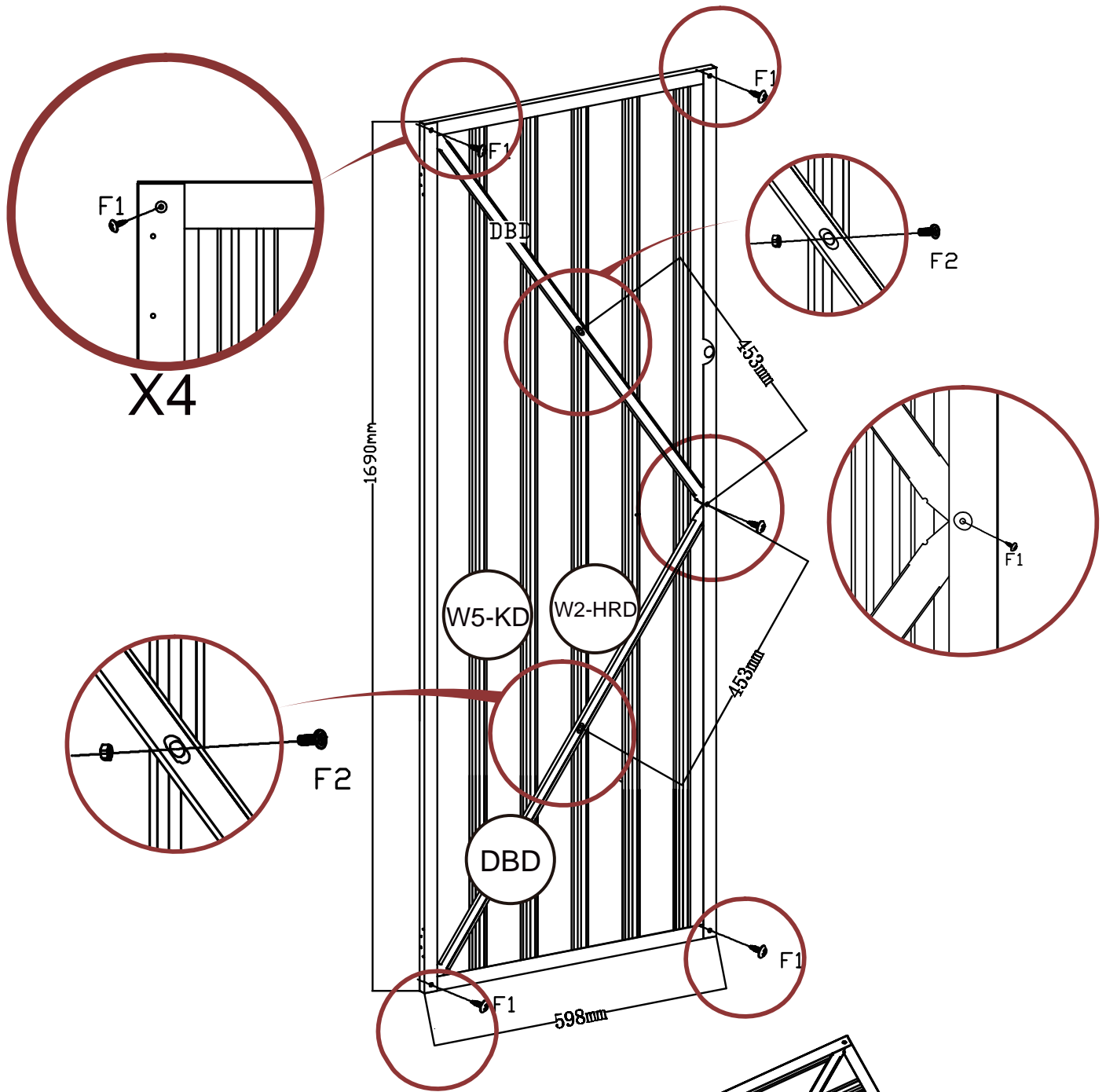



	F1	5
	F2	2

STEP 28

DL

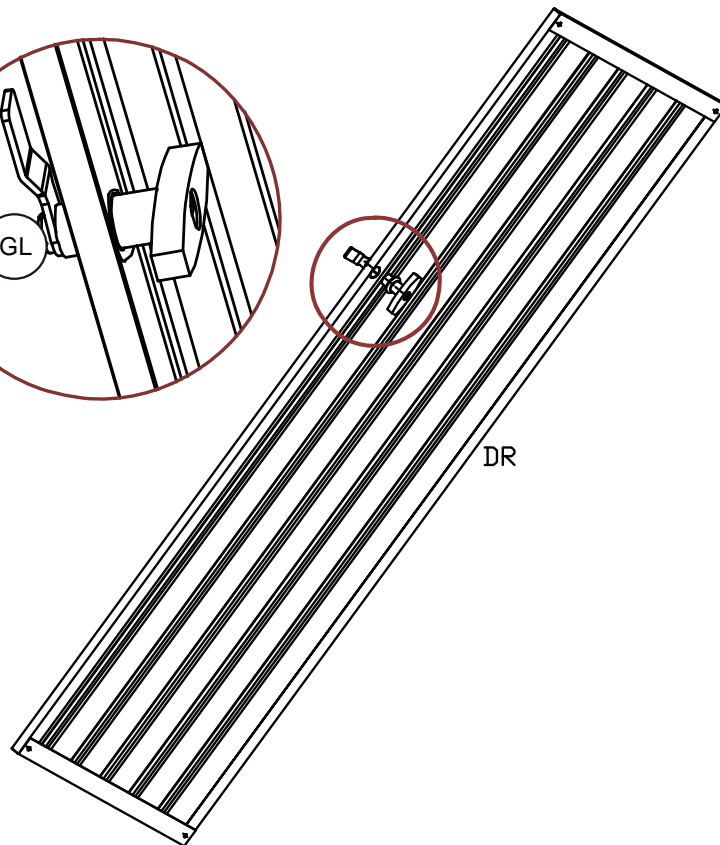
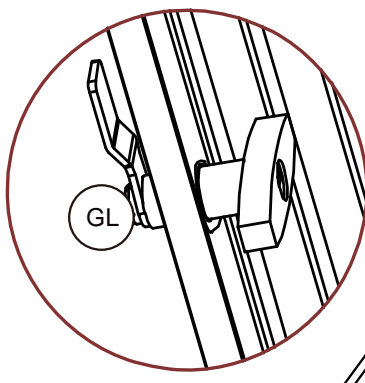
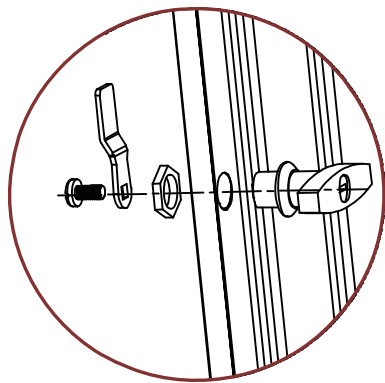
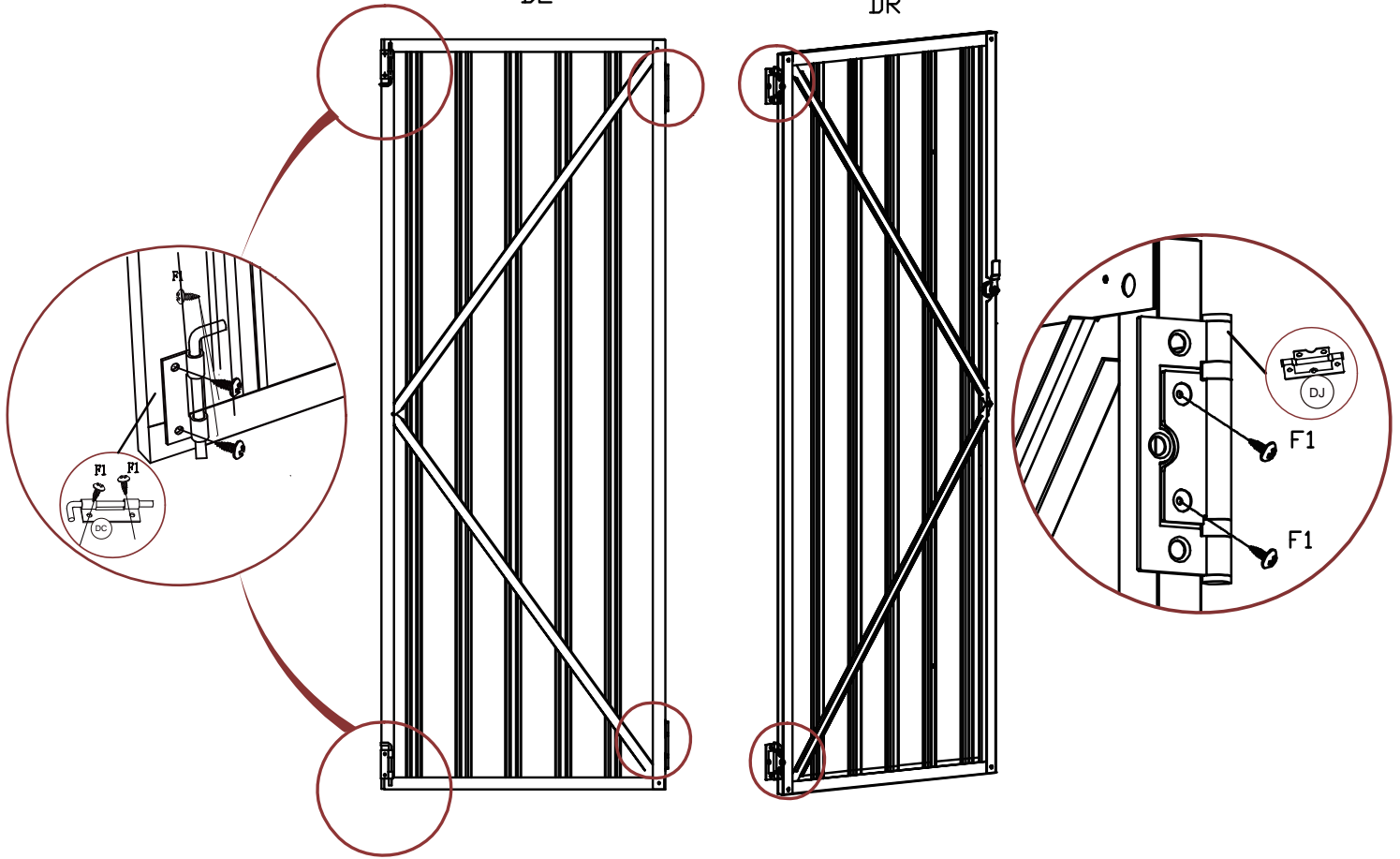
DR



	F1	12
---	----	----

STEP 29

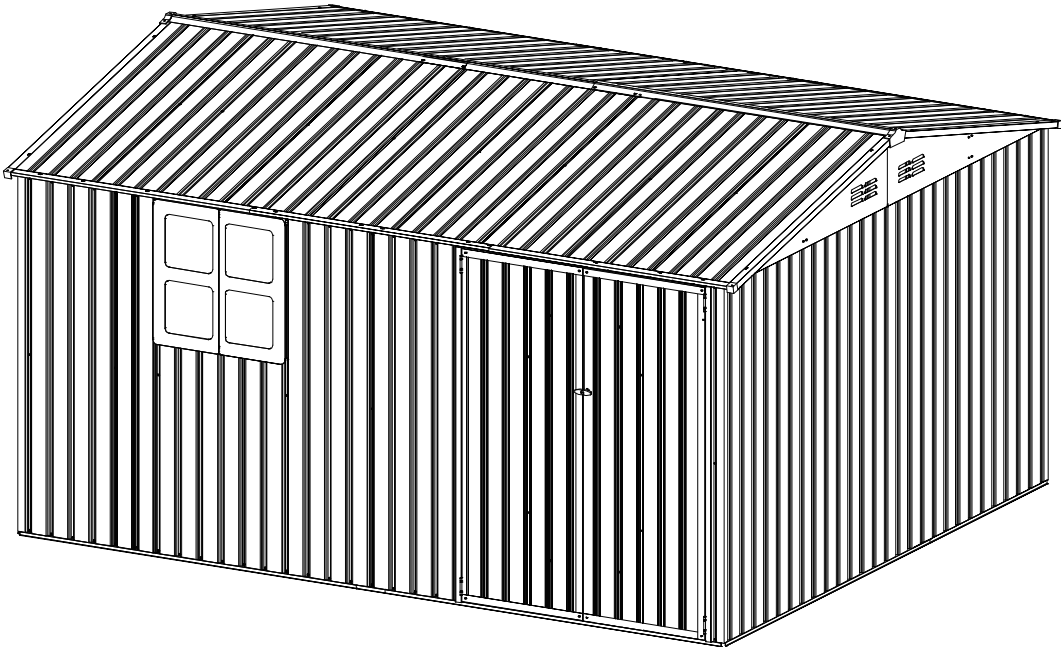
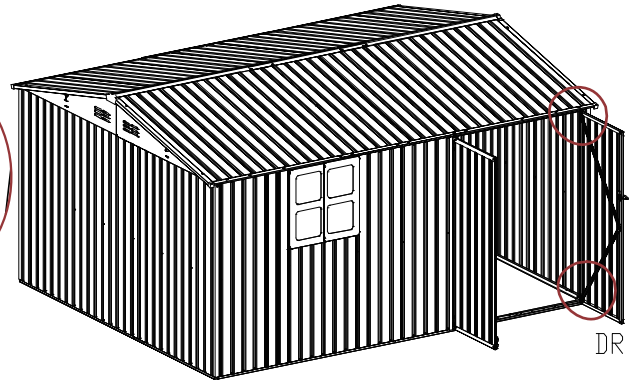
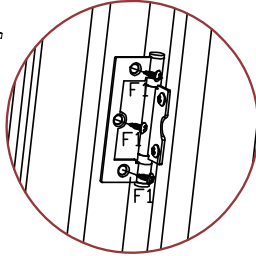
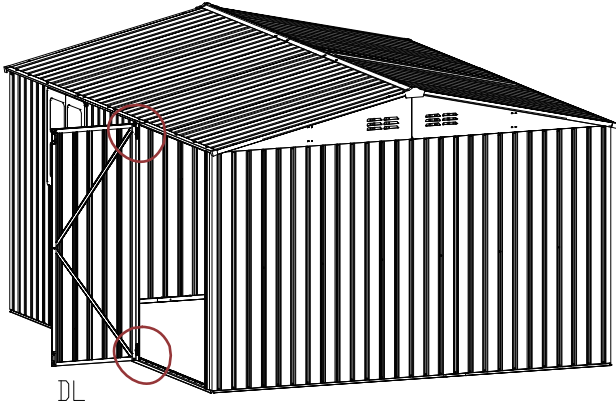

	F3	16
---	-----------	-----------

STEP 30

The exposed part of the assembly screw of the upper crossbeam support rod K1012-11 needs to be covered with a plastic protective cap.

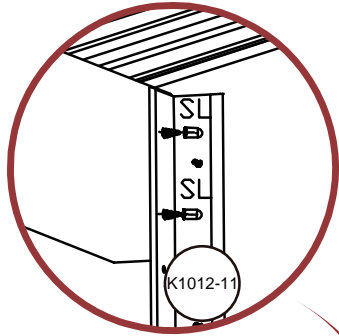

X4

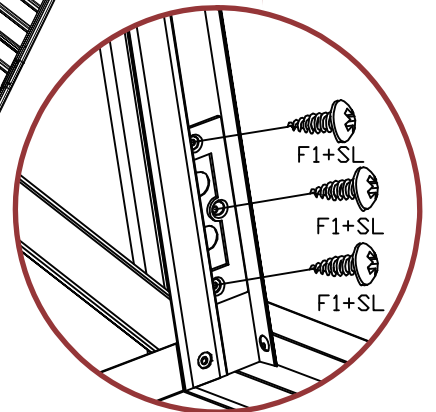
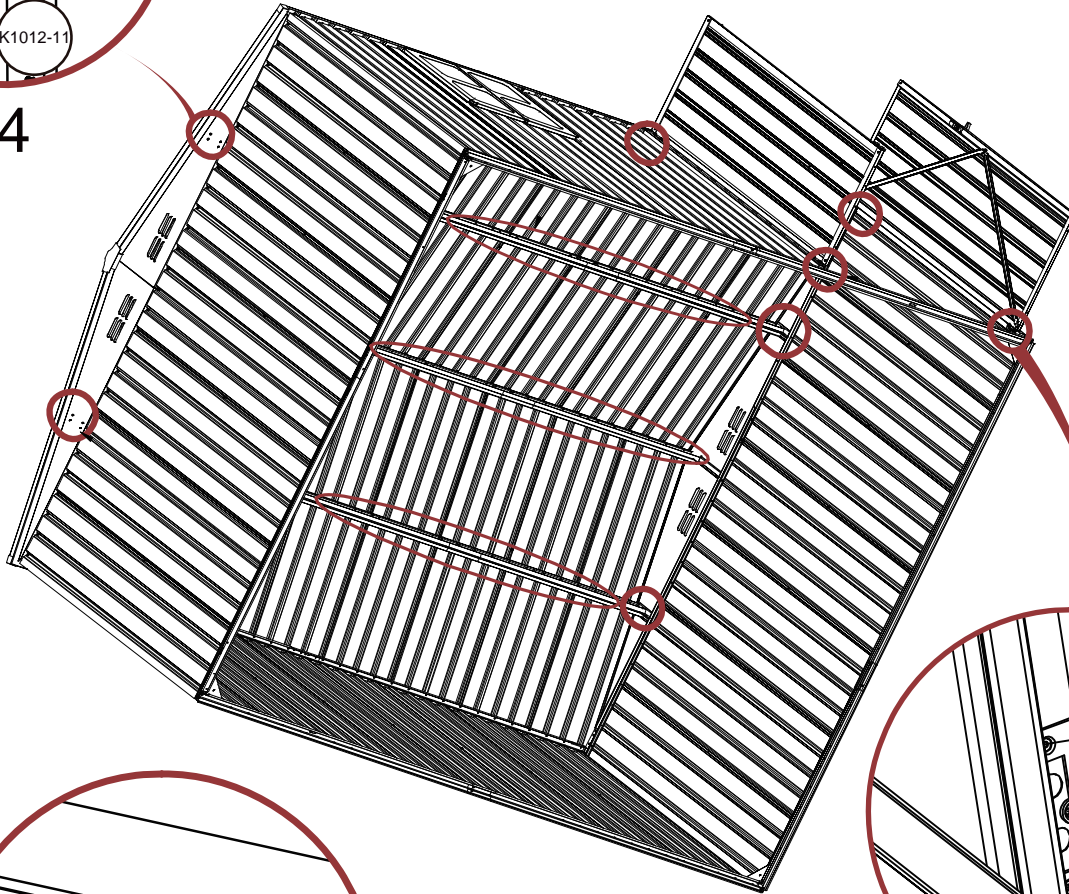

X4

The exposed part of DJ assembly screws needs to be covered with a plastic protective cap.

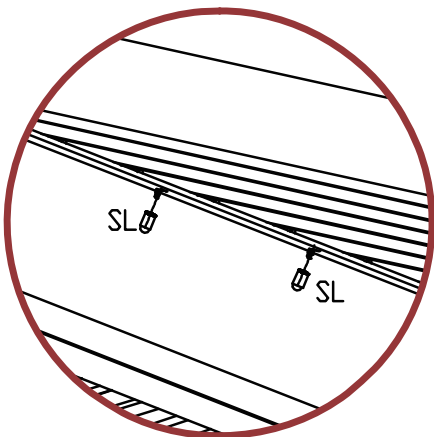

X3

The exposed parts of the assembly screws for the upper crossbeam K812-6L, K812-6M and K812-6R need to be covered with plastic protective caps.