

Assembly Instructions

Caution: You must read this before you proceed

Please look in the Leg Frame for Hardware packs

Barstool

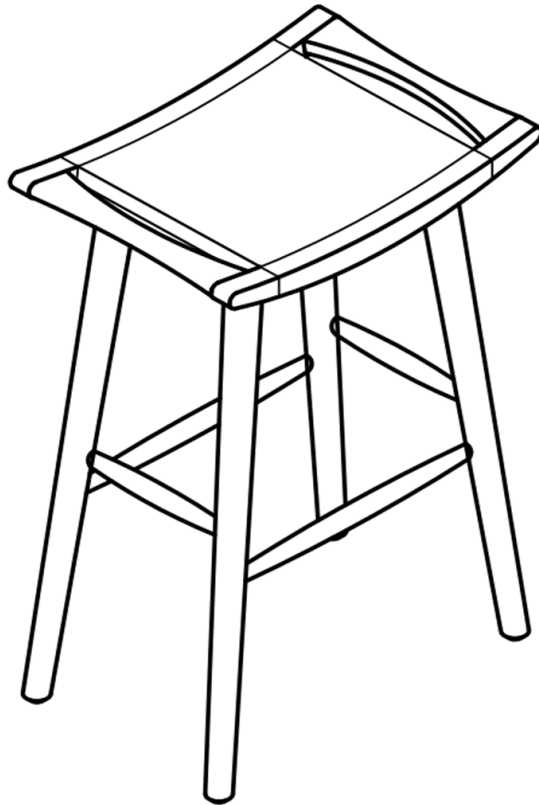



Caution: This Barstool is NOT a TOY.



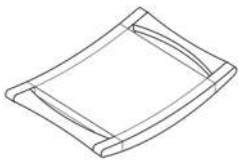

Keep your child/children at bay during the assembly process.

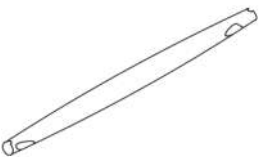
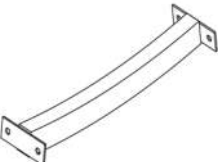
Whenever moving/lifting the Barstool and to prevent any possible damage to it, two adults are required to execute these actions.

Part List

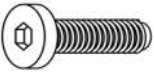
Label	Picture	Description	QTY
A		Seat Panel	1
B		Leg Frame	2
C		Leg Support Bar	2
D		Seat Support Bar	1

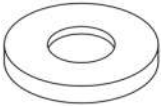
Hardware

Label	Picture	Description	QTY
①		Screw (M6x45mm)	5
②		Bolt (M6x15mm)	5
③		Bolt (M6x45mm)	5
④		Washer (M6.5/16x1mm)	5
⑤		Allen Key	1

Assembly Preparation

Before Beginning Assembly:

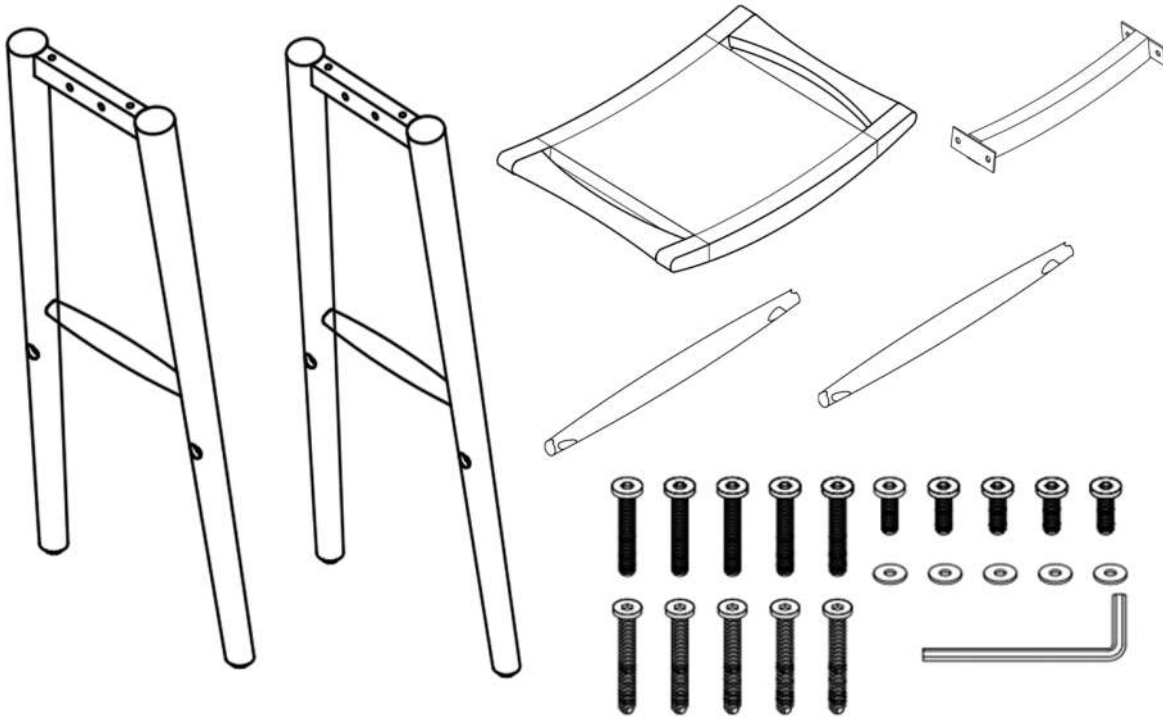

- Read instructions, cover to cover-



- Have 2 adults on hand for assembly-



- Do not assemble on flooring or carpet-



- Assemble on a clean non-marring surface (packing foam)-



- Save all packaging until finished-

Assembly Steps

Overview

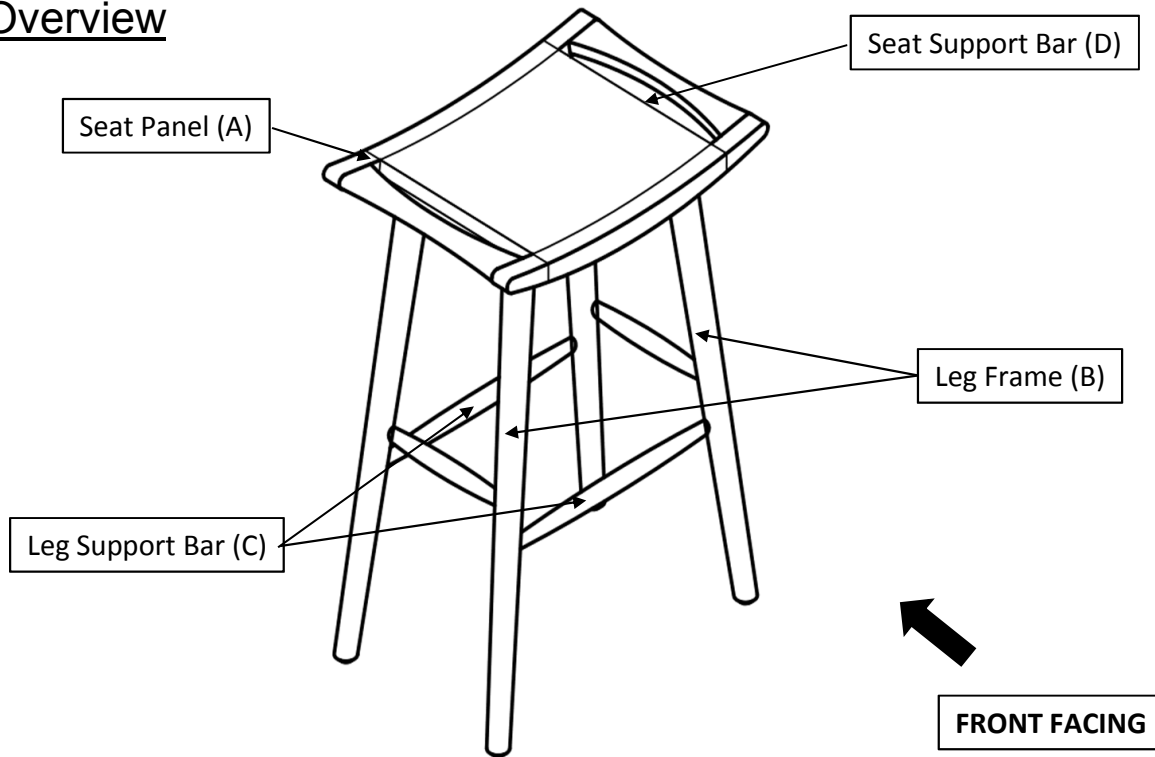

This Barstool has multiple parts and may require up to 30 minutes to assemble. To give you an overview of the Barstool parts, the above picture is to help you put the various parts into perspective. Please read through the instructions below to familiarise yourself with the parts and steps before assembly.

Step 1

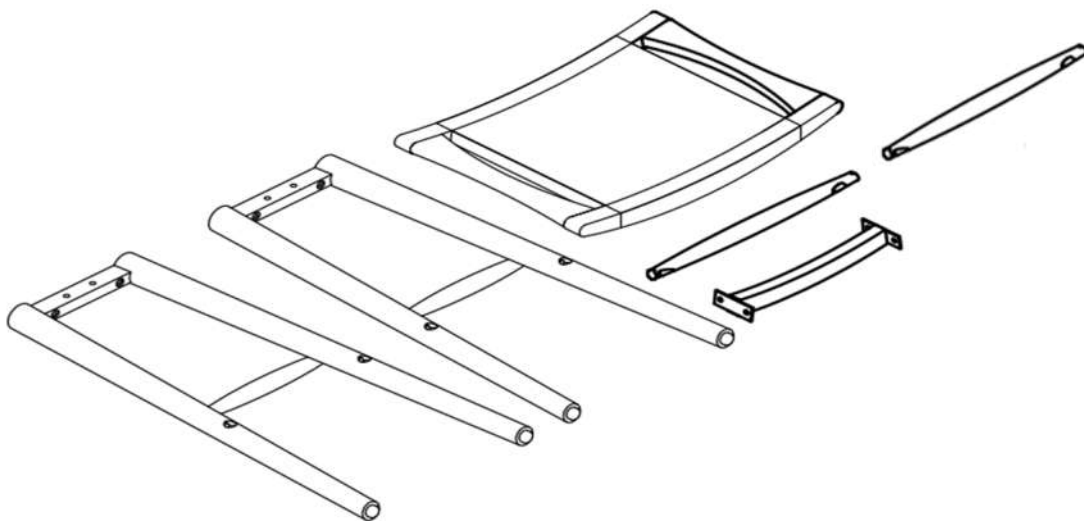

Unpack and place all parts on a clean, non-marring surface.

Step 2

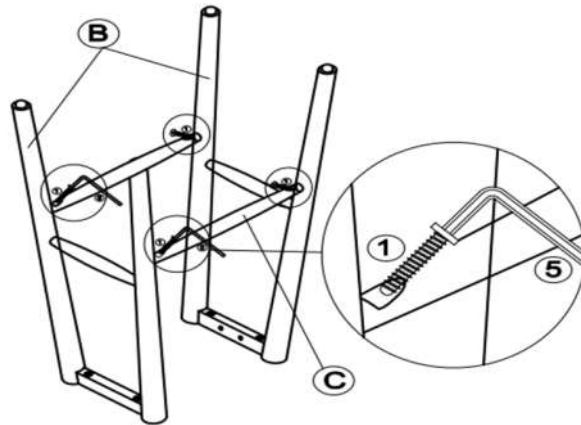

With assistance from your adult partner, attach the Leg Support Bar(C) to the Leg Frame(B) using 4 Screws(①) and the Allen Key(⑤) as shown in the above picture.

Do not fully tighten Screws.

Step 3

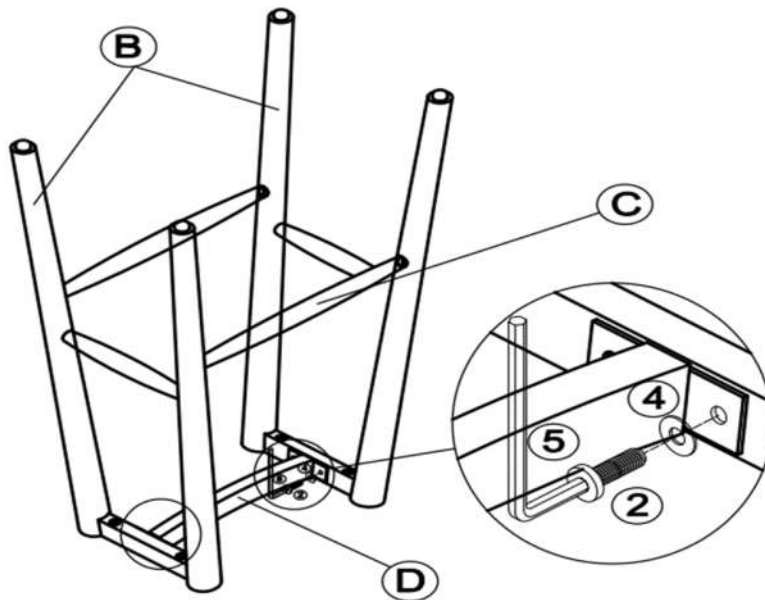

Align the Leg Support Bar(D) to the Leg Frame(B) as shown in the above picture.

Attach the Leg Support Bar(D) to the Leg Frame(B) using 4 Bolts(②), 4 Washers(④) and the Allen Key(⑤) as shown in the above picture.

Do not fully tighten Bolts.

Step 4

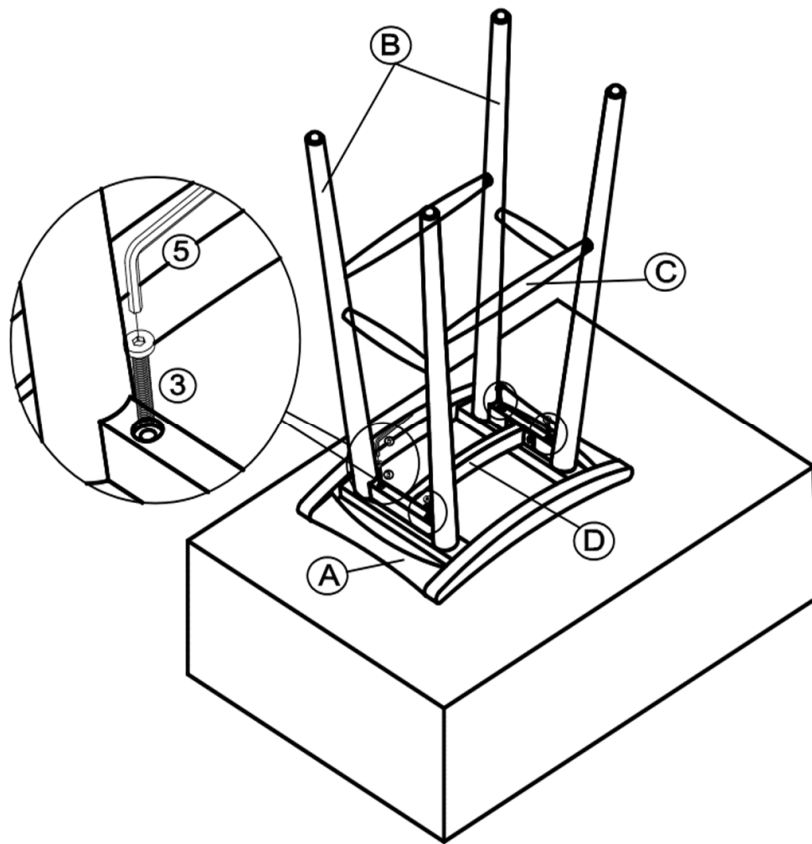

Place the Seat Panel(A) onto a table or a box as shown in the above picture. You will have the Barstool bottom and legs facing up. Attach the Leg Frame(B) to the Seat Panel(A) using 4 Bolts(③) and the Allen Key(⑤) as shown in the above picture.

Do not fully tighten Bolts.

Step 4

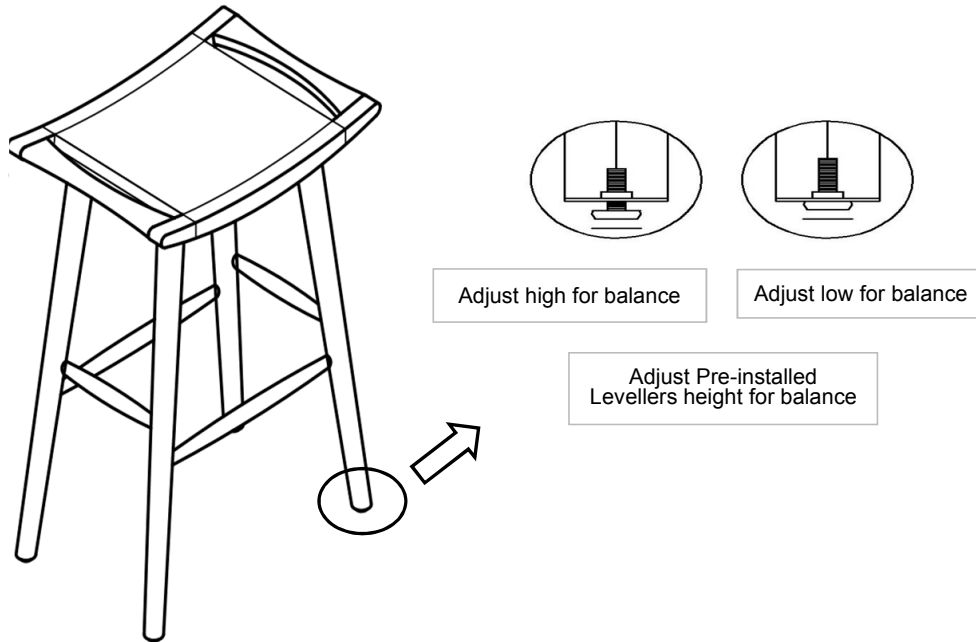

With the assistance from your adult partner, stand the Barstool up.

Inspect it and make sure all parts are adequately connected.

Carefully sit onto the Barstool. This pressure will help align all parts at all joints. Then get off the Barstool and proceed to tighten the Bolts and Screws in a sequential manner.

When tightening the Bolts and Screws tighten sequentially.

DO NOT tighten any Bolt or Screw fully and then move on towards the next one.

If there are any wobbles after tightening, loosen the Bolts and Screws and execute this same process.









Adjust the Levellers until the Barstool is level with the ground.

To adjust the Levellers, get assistance from an adult partner to lift/lean and hold the Barstool while you are working.

Your Barstool is ready for use.

This Barstool can only be used on a flat, level surface.

Care & Maintenance

-  Do not put hot items directly on furniture surface
 -  Do not clean furniture with harsh cleansers or polish.
 -  To obtain the longest lifespan of your outdoor products, minimizing exposure to direct sunlight is recommended.
 -  Children should not climb or jump on the furniture.
 -  Do not write on furniture without a padded barrier to protect the surface.
 -  To obtain the longest lifespan of your outdoor products, avoid extended and lengthy exposure to rain, snow, and direct sunshine. Whenever possible cover the product and /or place under patio or awnings.
 -  Not for commercial use. For residential use only .
 -  Stains may be removed with mild soap solution and damp cloth.
-
-  Dust and pick-up spills using a clean, non-colored, lint-free cloth .