

ADAPTABLE WASTE PUMP FOR TOILET

MACERATOR PUMP

HEBEANLAGE

Installation and Utilization Instructions



WARNING!!!

1. Please read the manual carefully before installation
2. Avoid chemical solvents, strong acids and alkali entering the machine
3. Only toilet paper, fecal matter and waste water can be disposed Do not throw any other kinds of waste into the toilet
4. Shower waste can be disposed without a cutter
5. Avoid too much hair into the machine
6. When installing the device, placing a check valve is necessary
7. Make sure that waste water flowing from equipment automatically enters the pump
8. Keep the device dry and away from humid environments
9. Do not let children play with the machine
10. Maintenance should only be performed by qualified professionals
11. Disable electrical power and remove the plug from the socket before performing repairs on the device
12. Install a leakage protector socket & earthing conductor

Technical

Power:	600W	Voltage:	110~120V /60Hz
Horizontal discharge:	90M	Vertical discharge:	9M
Max. Water temperature:	65'C(80'C in 1 hour)	Thermal protection:	90'C
Max. flow rate:	145L/Min	IP rate:	IPX4

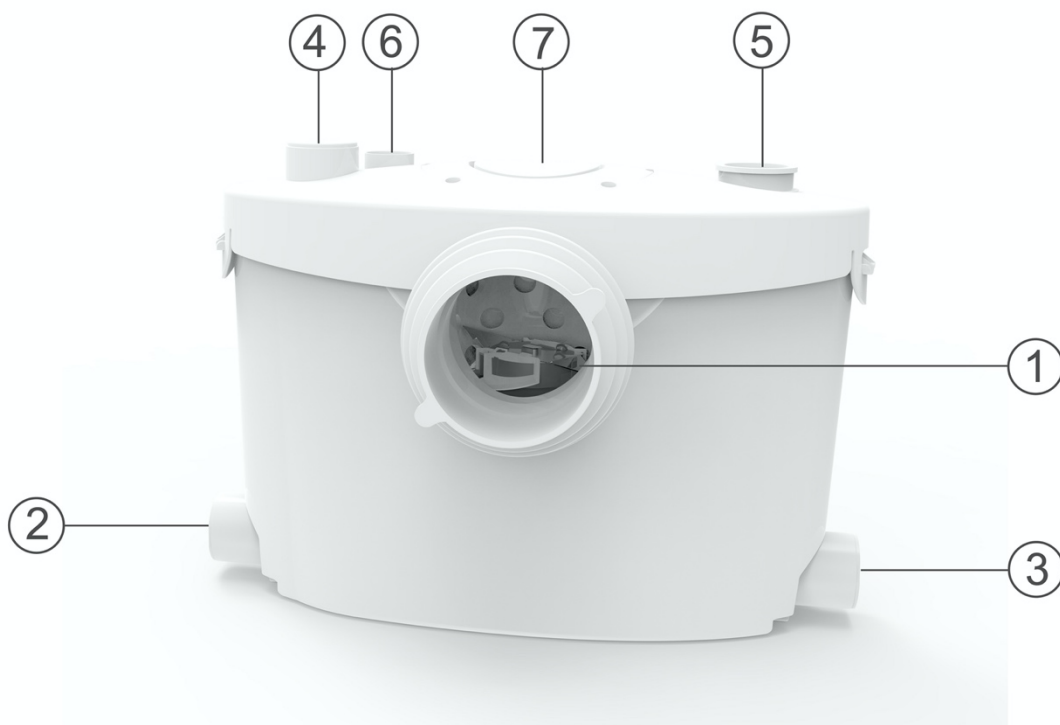

① Inlet for Toilet ϕ 100mm	② Inlet ϕ 40mm
③ Inlet ϕ 40mm	④ Inlet ϕ 40mm(Optional)
⑤ Outlet ϕ 23/28/32/44mm	⑥ Air-Vent/Carbon Filter
⑦ Repair Panel	

Fig1: Size

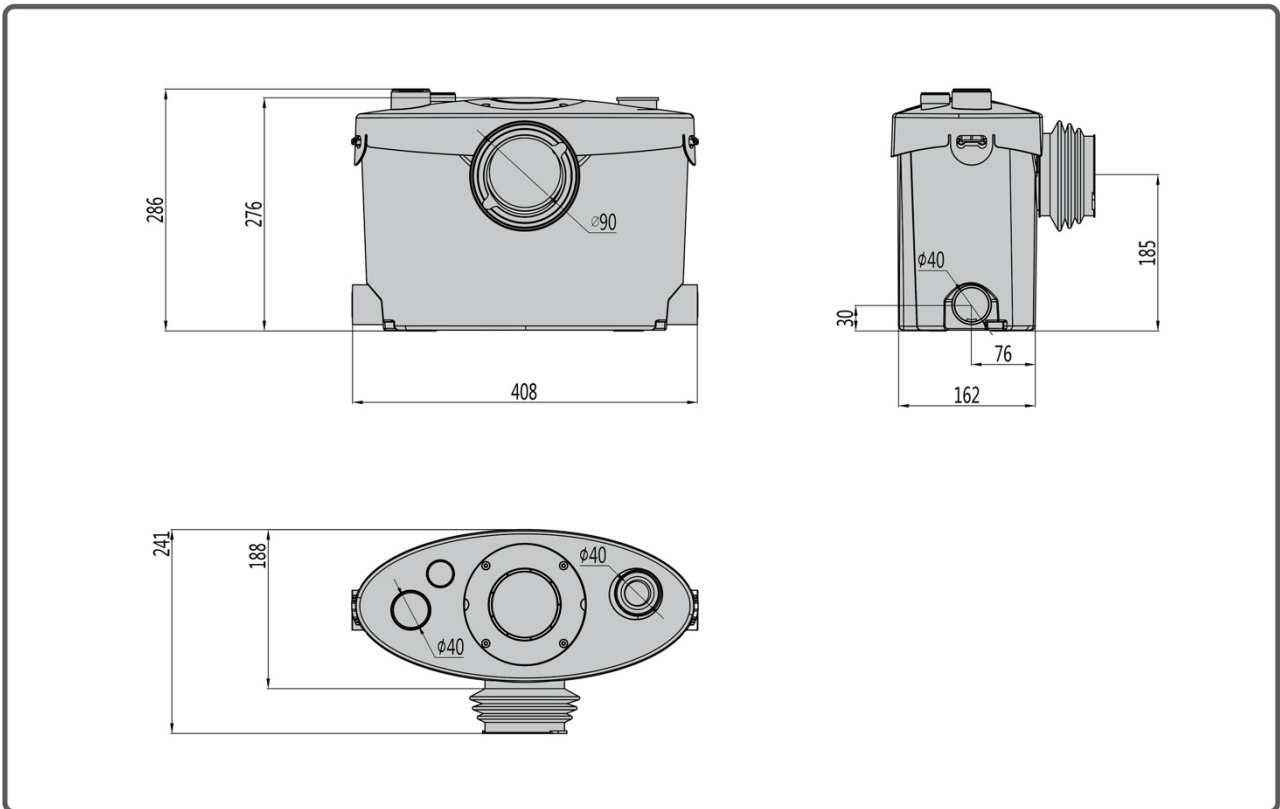

Fig2: Spare parts

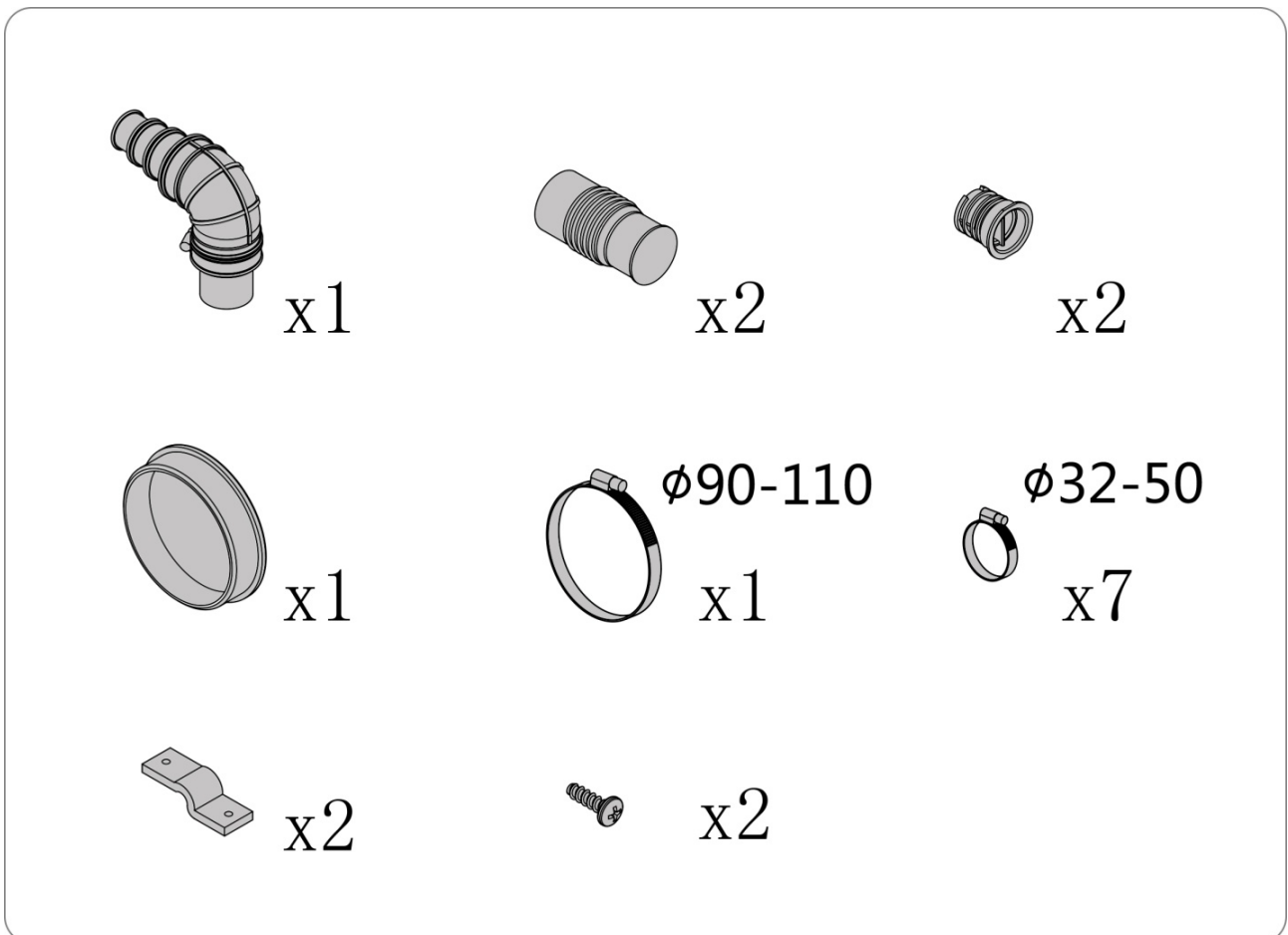

Fig3: Equipment

1, Outlet check valve is necessary

2, Install an extra manual check valve for repair (Suggestion)

3, Lift the shower 14cm high, when you connect the side inlet

4, Using filter in shower & lavatory to reduce hair come into machine

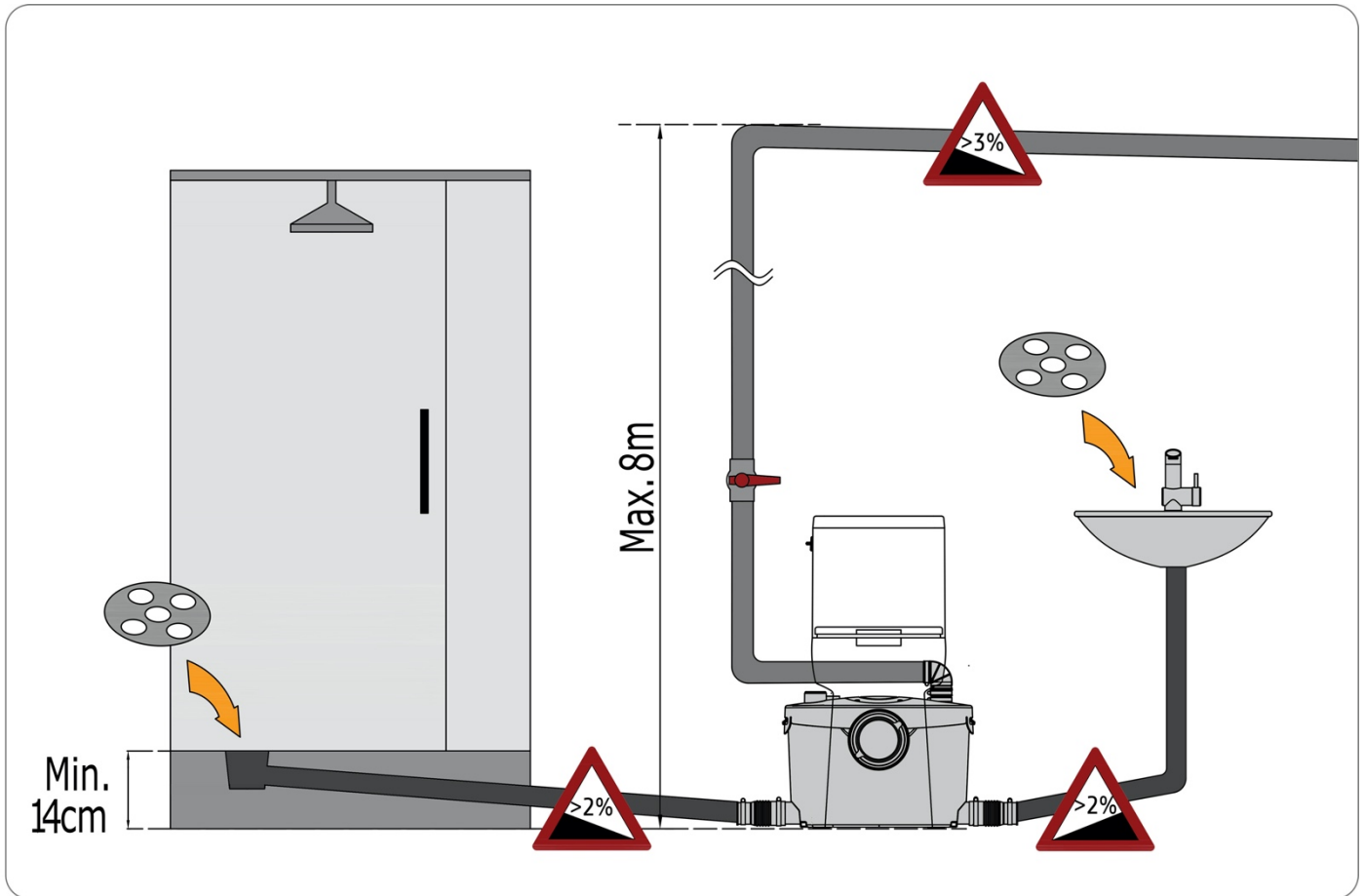

Fig4: Connection

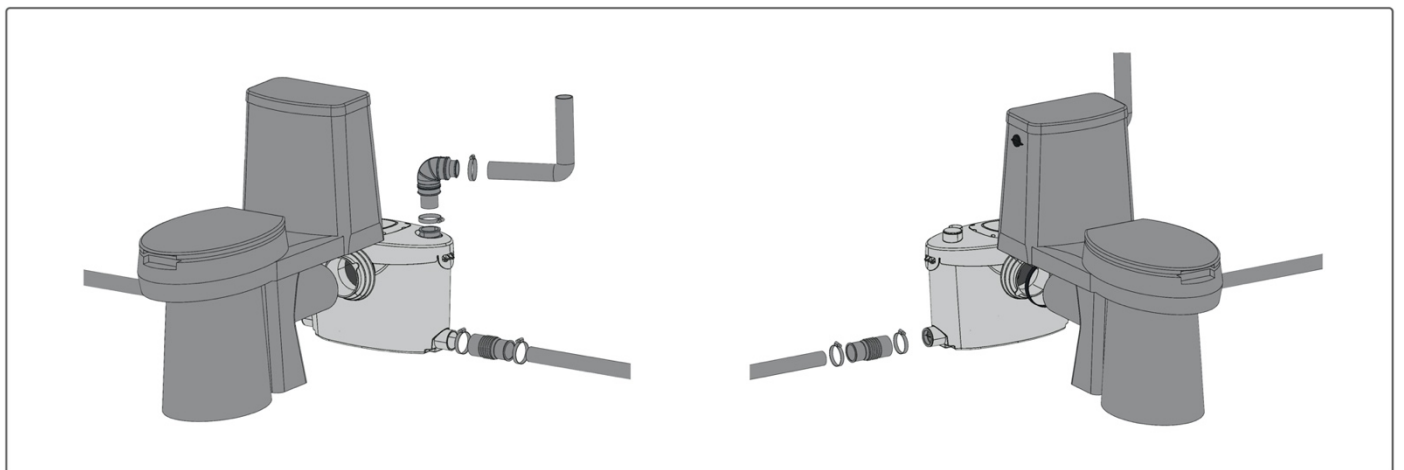

Fig5: Optional inlet for extra Equipment

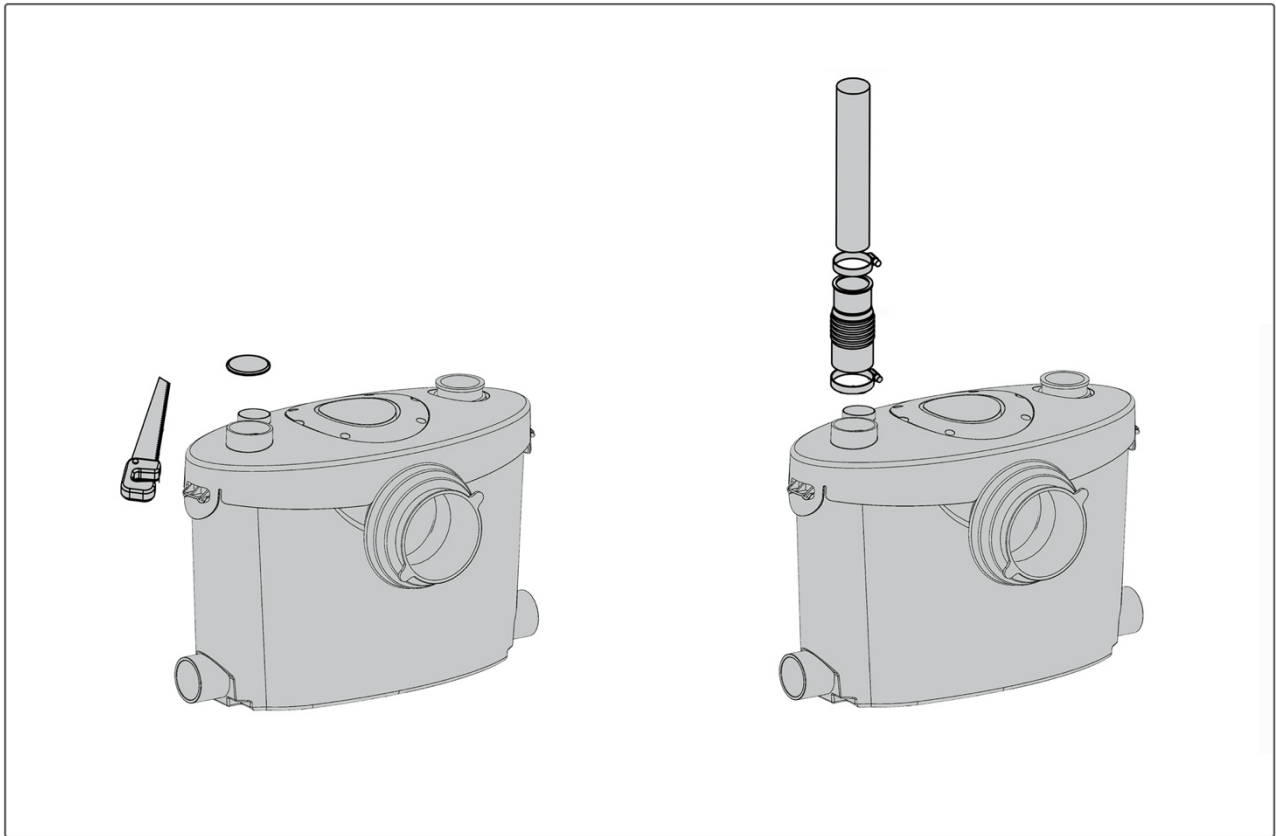

Fig6: Inlet cover (Cover the inlets for unused)

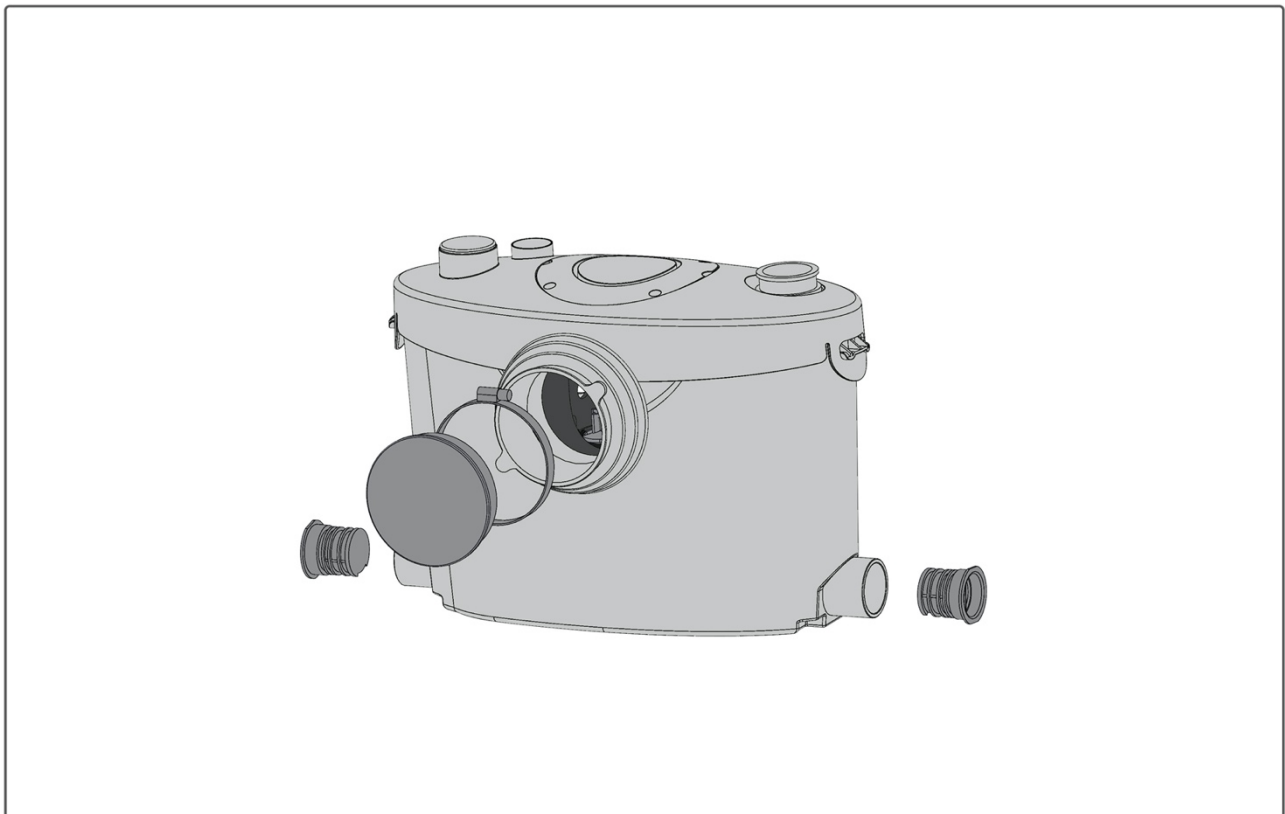

Fig7: Fixation

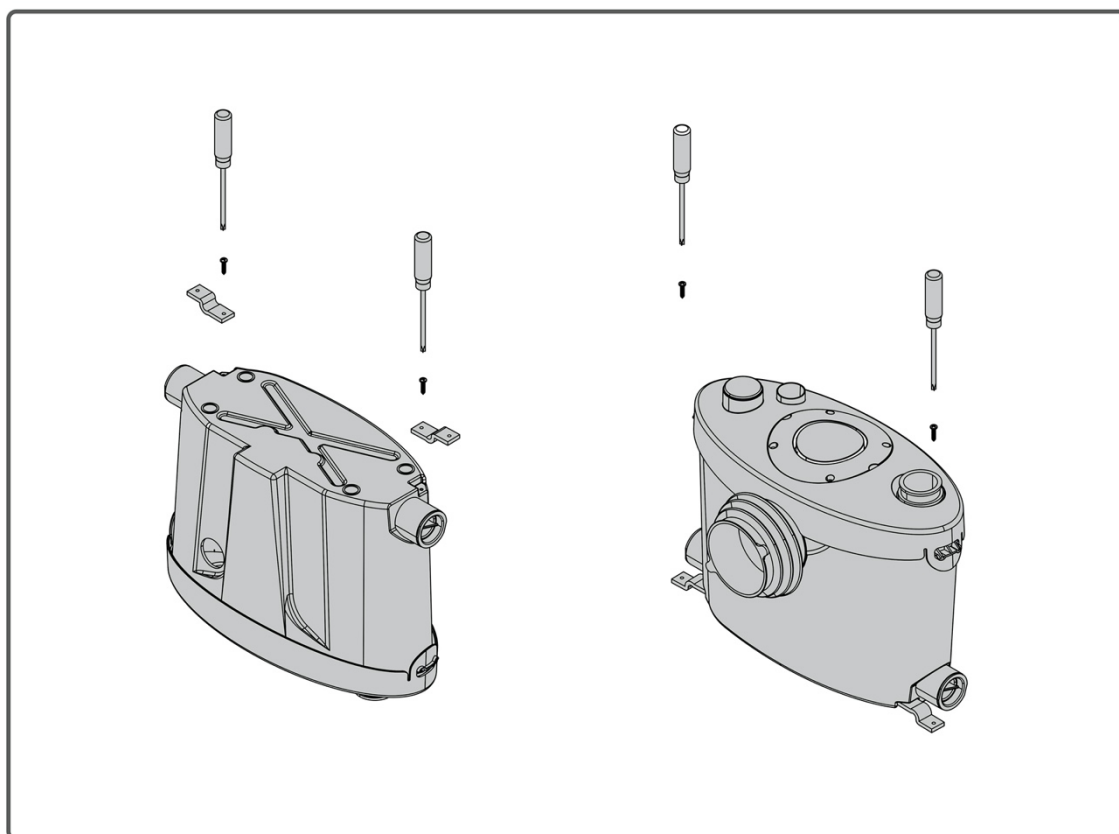

Fig8: Outlet (Check Valve)

Discharge pipe insert the check valve is only 1~2CM, avoid too much insert

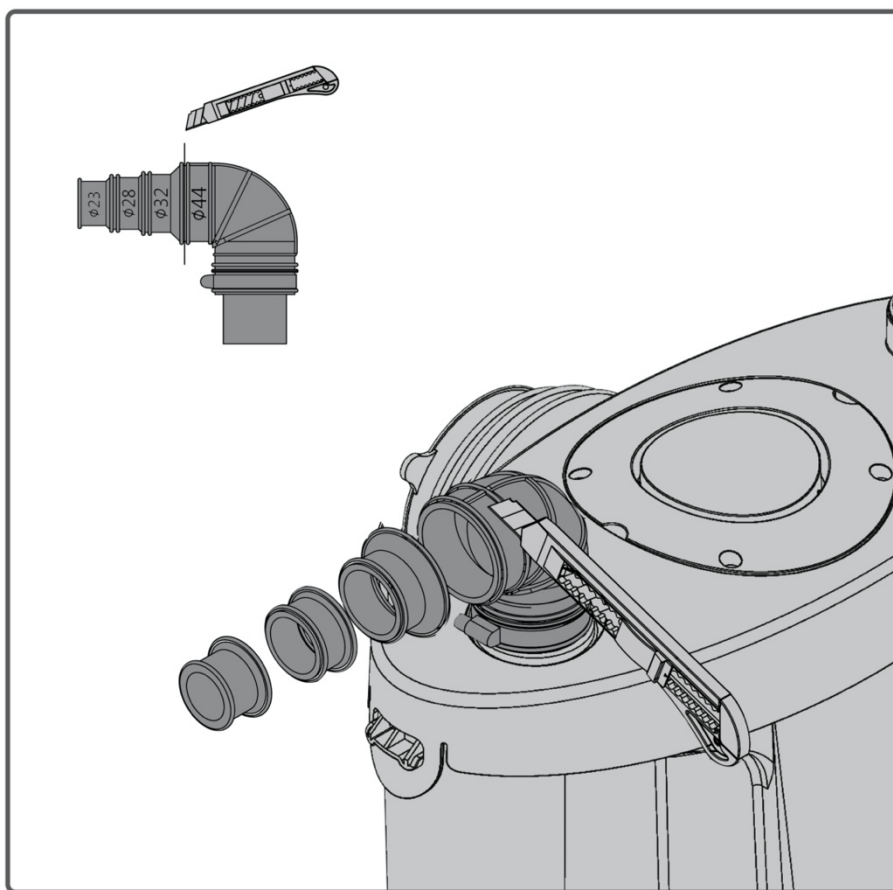

Fig9: Repair Panel

Open the top repair panel, you can easy to take out the block near the blade

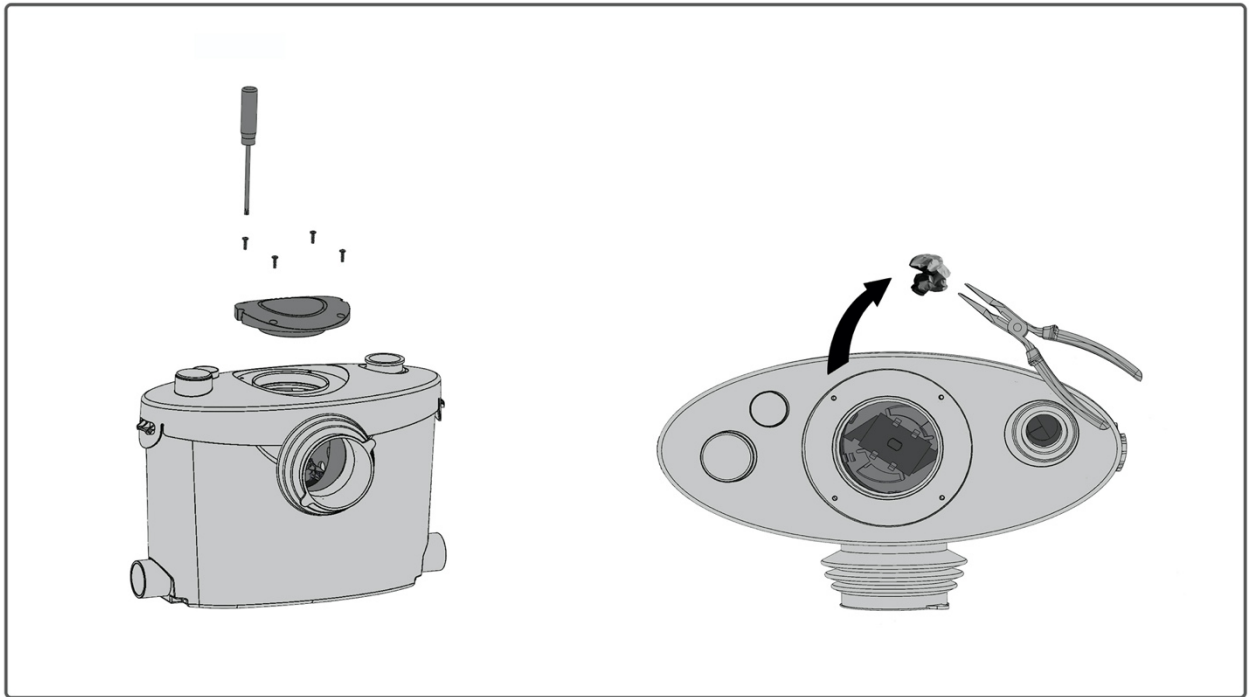

Fig10: Pumping head

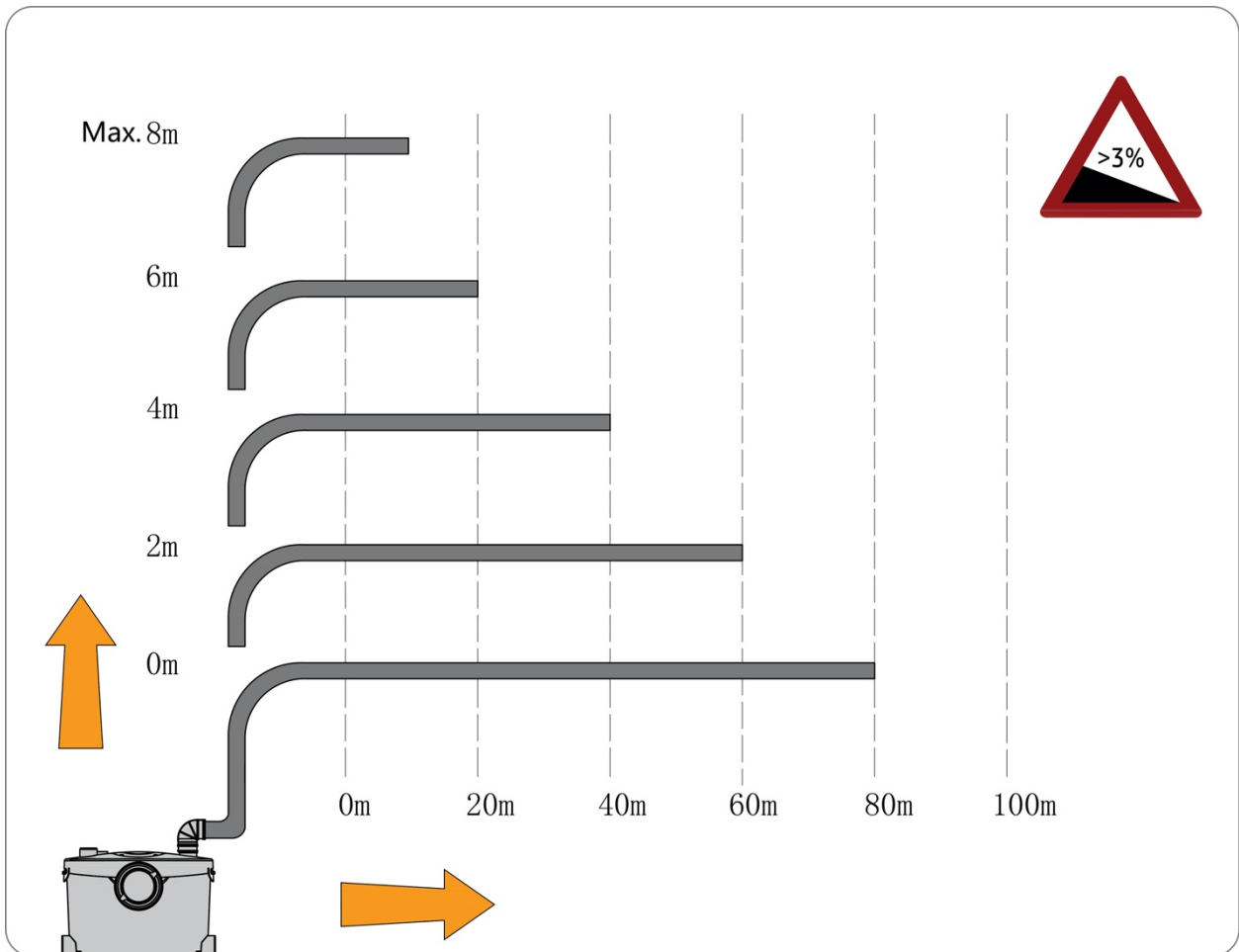

Fig11: Flow Rate

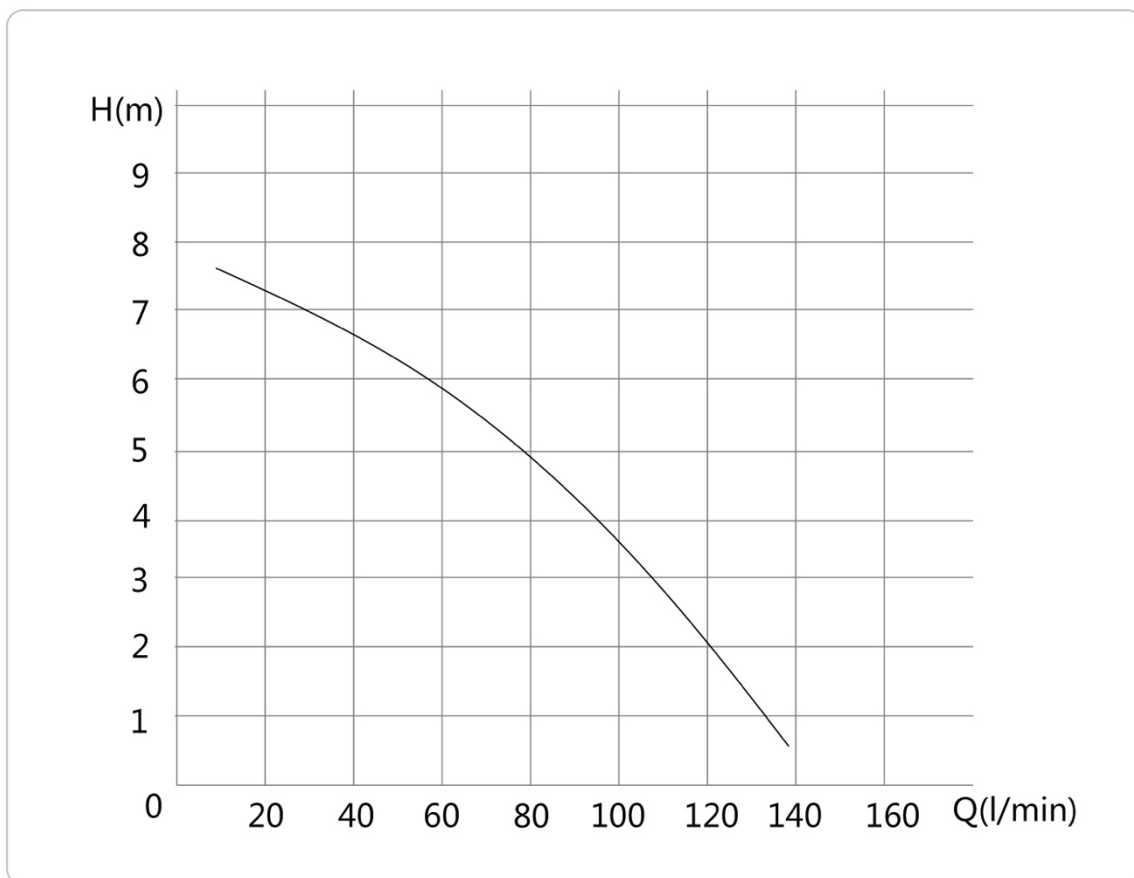

Fig12: Min Size from toilet outlet to rear wall is 245mm

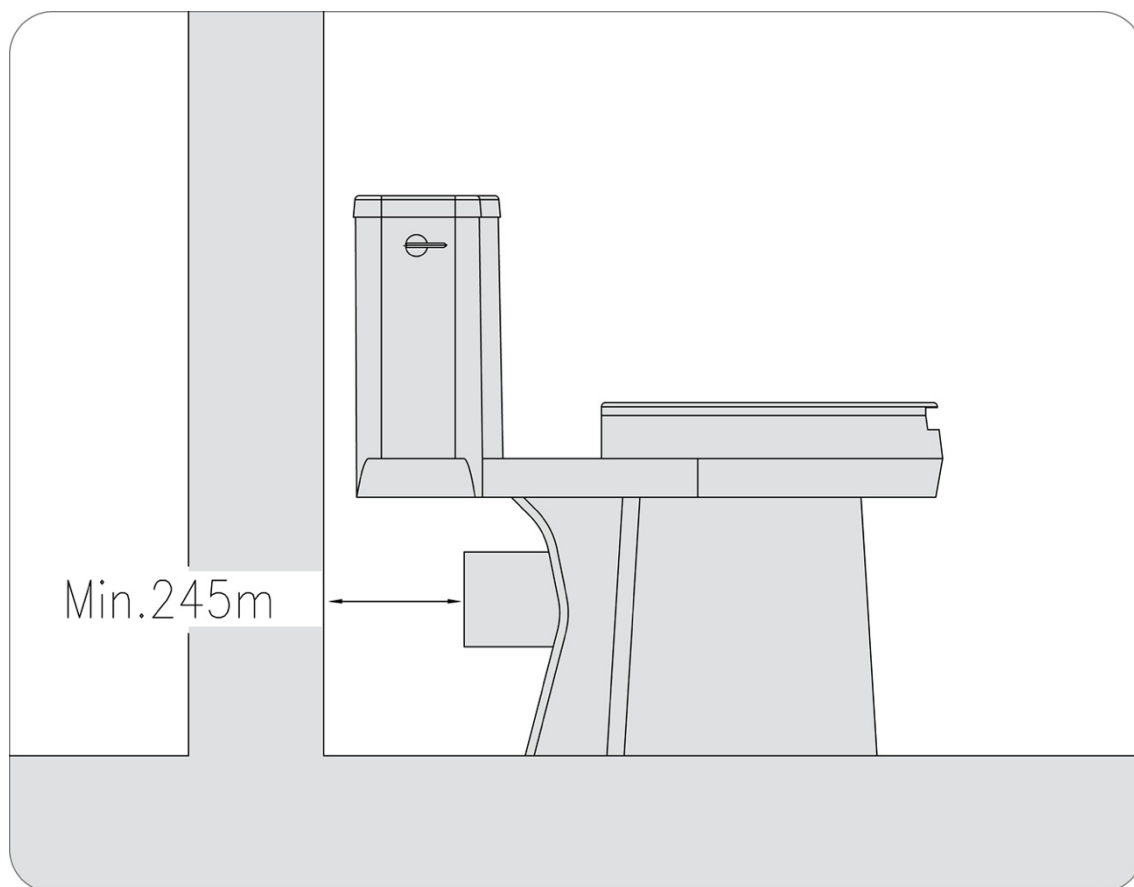

Fig13: angle

We suggest to using 2pcs 45' elbow to instead of 1pc 90' elbow

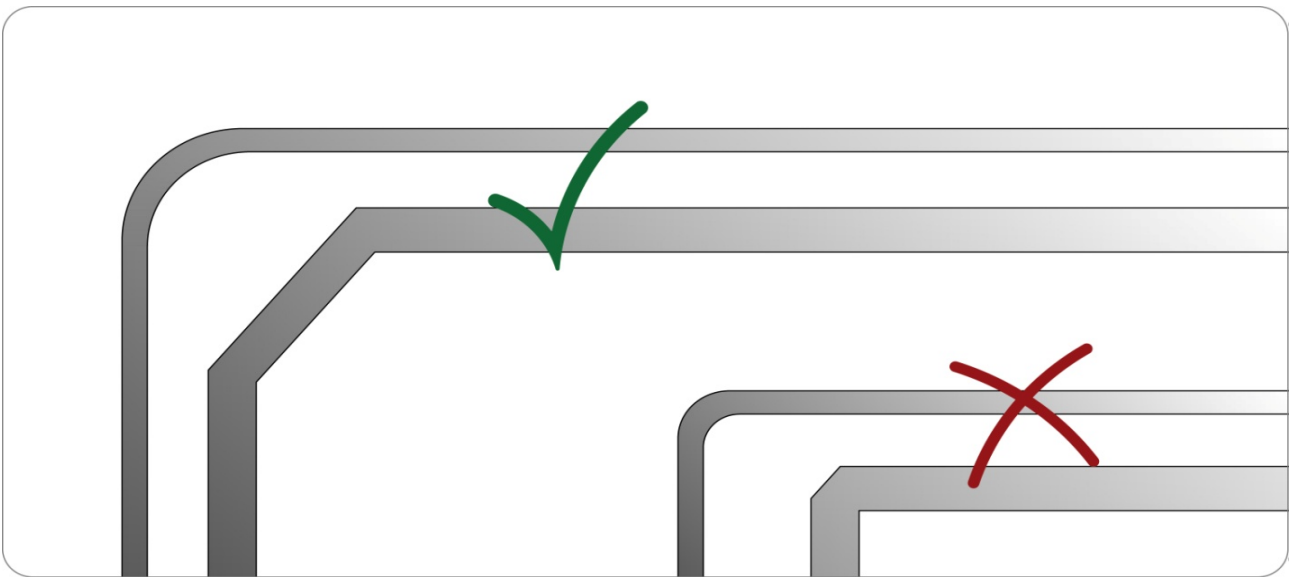
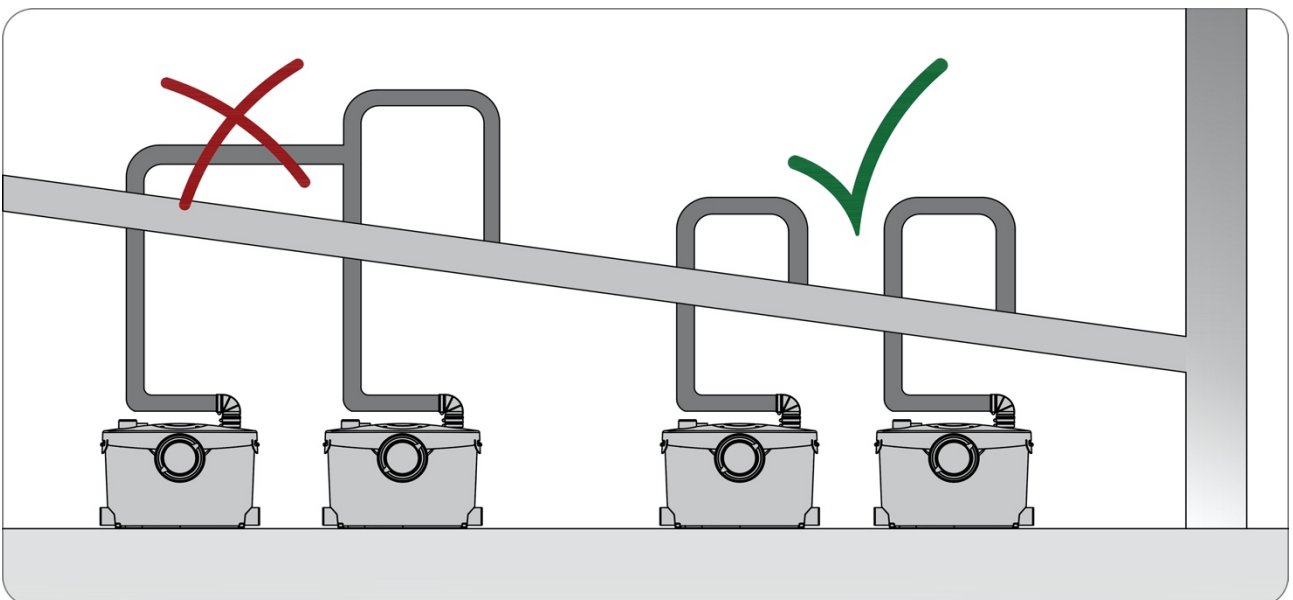
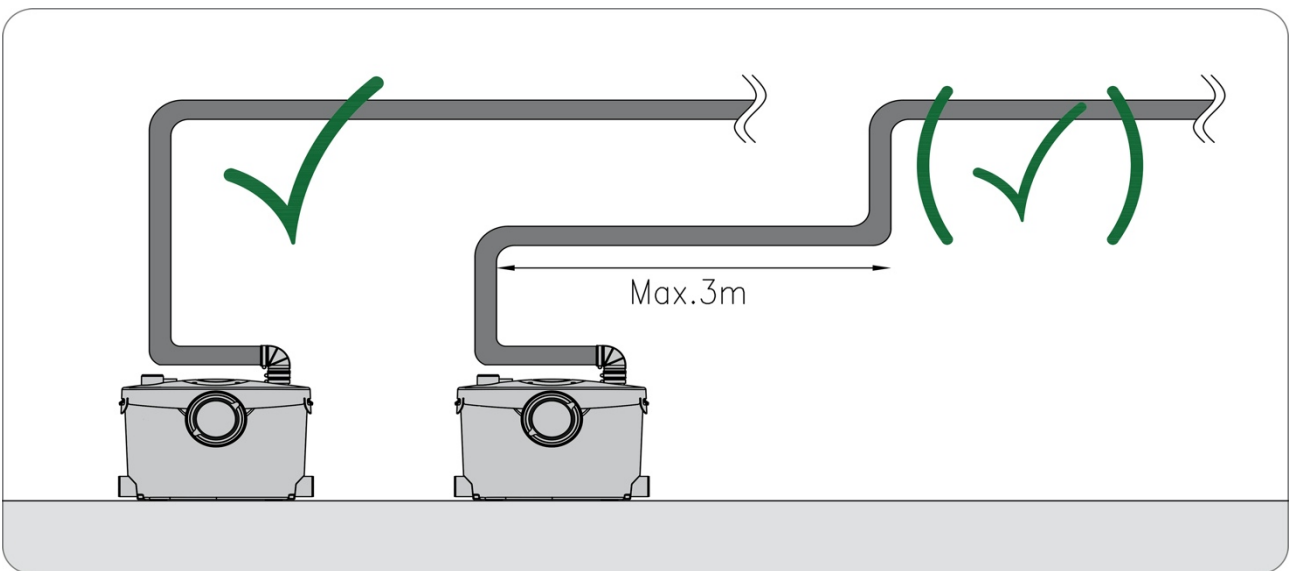

Fig14&15: Discharge Pipe connection



1. Warning

- The appliance is only ready for use after installation.
- The appliance must be supplied through a residual current device (RCD) having a rated residual operating current not exceeding 30mA.
- If the supply cord is damaged, it must be replaced by the manufacture or its service agent or a similarly qualified person in order to avoid a hazard.
- This appliance is not intended for use by persons (including children) with reduced physical, sensory or mental capabilities, or lack of experience and knowledge, unless they have been given supervision or instruction concerning use of the appliance by a person responsible for their safety.
- Children should be supervised to ensure that they do not play with the appliance.
- This appliance is of domestic use only

2. Operating principle

The pump has been designed to pump away the waste from toilet and other sanitary appliances. The pump for toilets comprises an electric pump(D) that is automatically controlled by a float switch(C).

The discharge action is triggered when the flushing system is actuated, as with a conventional toilet. See picture.

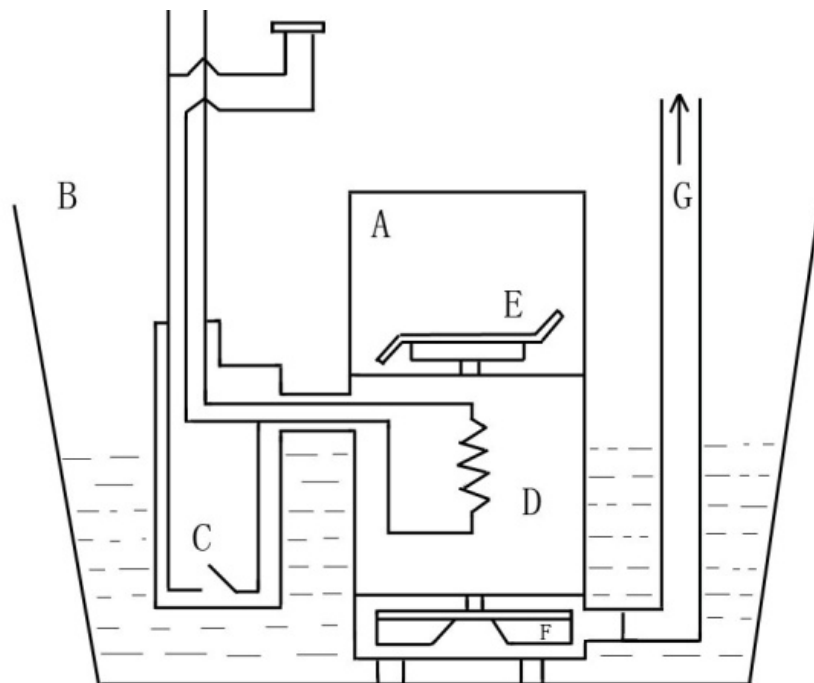

3. Installation

3a Toilet CONNECTION

- First, put some silicon or liquid soap on the toilet spigot
 - Fit the collar supplied on the bowl outlet
 - Pull the flexible sleeve over the pan spigot
 - Position the jubilee clip over the edge of the flexible sleeve, and tighten with a screwdriver
 - Once the appliance has been positioned, fix it to the floor using the 2 screws supplied.
- If using the two floor fixing lugs, secure them to the floor before positioning the unit.

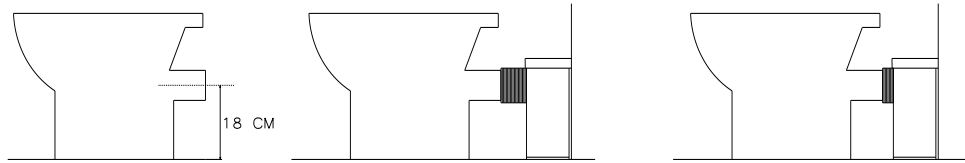

WARNING !!!

There should be no dripping of water from the toilet cistern or any other sanitary appliances. If there is, this will cause the unit to activate repeatedly as it pumps the water away.

3b CONNECTION OF DISCHARGE PIPEWORK

Insert the discharge elbow into the rubber discharge pipe, turn to the desired direction and secure with the metal jubilee clip provided (36-50mm). Then connect the hose to it using the 20-32mm metal jubilee clip, making sure the hose is not kinked. A 22-32mm plastic reducer is supplied if 32mm discharge pipework is to be installed.

3c TECHNICAL ADVICE FOR DISCHARGE PIPEWORK

- Horizontal pipe runs must have a minimum fall of 1:200 (5mm per metre) to the soil stack,
- If a vertical lift is required, it must be made before the horizontal run at the start of the piperun,
- We would recommend that a drain-off point is installed to allow the discharge pipework to be drained down before any service work
- If the discharge pipework runs to a level considerably lower than the unit, the resultant syphoning effect can suck out the water seal in the unit. Fitting an air admittance valve (BBA approved) at the high point of the pipe run will overcome this problem,
- The discharge pipework must be connected • to the soil stack using an appropriate strap on boss, Ensure all external pipework is adequately lagged to avoid the possibility of freezing.

N.B.: Any elbow on the discharge pipe of the unit will create friction loss (roughly 50 cm per elbow to be deducted from the vertical pumping spec.)

Always use smooth bends (OR 2 X 45 degree bends together) and not 90 degree elbows.

3d CONNECTION TO THE ELECTRICAL SUPPLY



The electrical installation should be carried by a qualified person.
The unit should be connected to a fully earthed electrical supply.

4 COMMISSIONING THE UNIT

Once electrical and pipe connections have been made, flush the toilet once. The motor should run from 5 to 10 seconds to clear the waste (depending on the height of the pipe run). If it runs for more than 20 seconds, check that the pipework is clear, and that the discharge hose is not kinked. Flush the toilet checking that all seals, and connections are watertight. Check both the discharge pipework from the unit and the other sanitary appliances connections.



The electrical installation should be carried by a qualified person.
The unit should be connected to a fully earthed electrical supply.

5 USAGE AND WARNING

WARNING !!!

If away for a long periods (eg holidays) we recommend that you turn off the water supply to the WC served by the unit.

Toilet connected to this unit can be used like any normal toilet, and requires minimum maintenance. The unit will operate automatically as soon as the required level of water enters the case.

The motor thermal protector will operated once the motor is overheat, unplug the plug from the socket-outlet, then plug again, the appliance will work normal after waiting about 30-60minutes.

WARNING !!!

Only the disposal of toilet papers, faecal matter, and waste water will be under guarantee. Any damage due to foreign bodies such as cotton, condoms, sanitary towels, wet wipes, food, hair, metal, wood or plastic objects, will not be under guarantee. Solvents, acids and other chemicals can also cause damage to the unit, and will invalidate the guarantee.

6 MAINTENANCE



DISCONNECT THE ELECTRICAL POWER SUPPLY, BEFORE ATTEMPTING ANY WORK ON THE UNIT.

No need of any particular maintenance.

This unit is fitted with an active carbon filter, and requires no external venting.



Correct disposal of this product

This marking shown on the product or its literature, indicates that it should not be disposed with other household wastes at the end of its working life. To prevent possible harm to the environment or human health from uncontrolled waste disposal, please separate this from other types of wastes and recycle it responsibly to promote the sustainable reuse of material resources.

Household users should contact either the retailer where they purchased this product, or their local government office, for details of where and how they can take this item for environmentally safe recycling.

Business users should contact their supplier and check the terms and conditions of the purchase contract. This product should not be mixed with other commercial wastes for disposal