

# PARTS LIST

Your 48" Bamboo Kitchen Island w/ Cabinet should include the following parts. Please inspect box contents to ensure you have received all components.

If you are missing any parts, need assistance with assembly or have questions, please contact Customer Service.

Two people needed to assemble. An electric screwdriver or drill is recommended for ease of assembly.

**A**

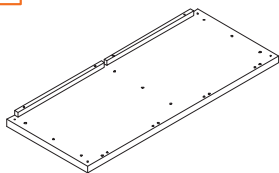

**TOP (1)**

**B**

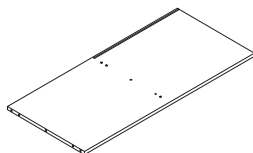

**BOTTOM SHELF (1)**

**C**

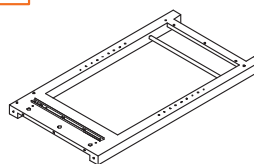

**LEFT SIDE FRAME (1)**

**D**

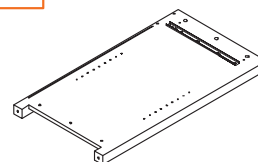

**RIGHT SIDE FRAME (1)**

**E**

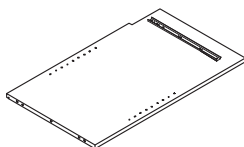

**DIVIDER (1)**

**F**

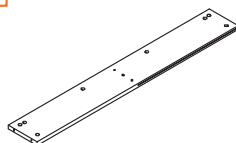

**BACK FRAME (1)**

**G**

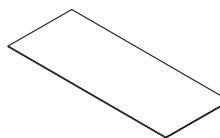

**CABINET BACK PANEL (2)**

**H**



**H SHAPE CONNECTOR (1)**

**I**

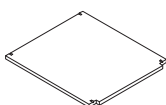

**SHELF (1)**

**J**

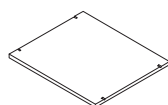

**CABINET SHELF (1)**

**K**

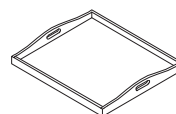

**TRAY (1)**

**L**

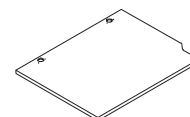

**DOOR PANEL (1)**

**M**

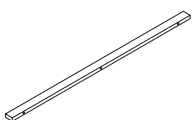

**LOWER SHELF FRAME (2)**

**N**

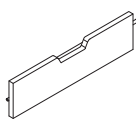

**DRAWER FRONT PANEL (2)**

**O**

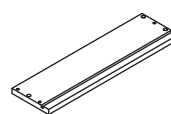

**DRAWER LEFT PANEL (2)**

**P**

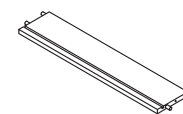

**DRAWER BACK PANEL (2)**

# PARTS LIST

Q

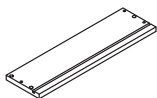

**DRAWER RIGHT  
PANEL (2)**

R

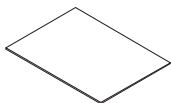

**DRAWER BOTTOM  
PANEL (2)**

S

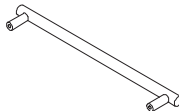

**HANDLE (2)**

T

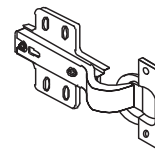

**HINGE (2)**

AA



**DRAWER  
SCREW (12) +  
(1) extra**

BB



**SHELF  
SUPPORT (9)**

CC



**HANDLE  
SCREW (4)**

DD



**HINGE  
SCREW (12) +  
(1) extra**

EE



**SCREW (9)**

FF

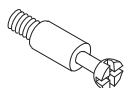

**CONNECTOR SCREW  
(24) + (1) extra**

GG



**CAM LOCK  
(24) + (1) extra**

HH



**DOWEL  
(20) + (2) extra**

II



**HANGER STUD (7)**

JJ



**WASHER (4)**

KK



**NON-LOCKING  
CASTER (2)**

LL



**LOCKING  
CASTER (2)**

MM

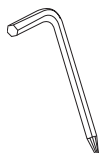

**SCREWDRIVER (1)**

NN

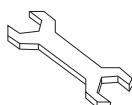

**WRENCH (1)**

# ASSEMBLY INSTRUCTIONS

## STEP 1

**Note:** To protect product from any scratches or possible damage, please make sure all bamboo parts are laid on a clean and soft cloth / surface during assembly process.

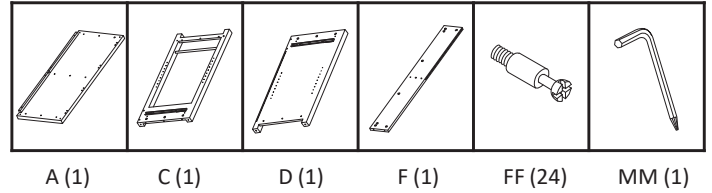

Lay all below pieces on a clean surface with holes facing up. Place and screw CONNECTOR SCREWS (FF) into holes with a SCREWDRIVER (MM) as shown:

- TOP (A)
- LEFT SIDE FRAME (C)
- RIGHT SIDE FRAME (D)
- BACK FRAME (F)

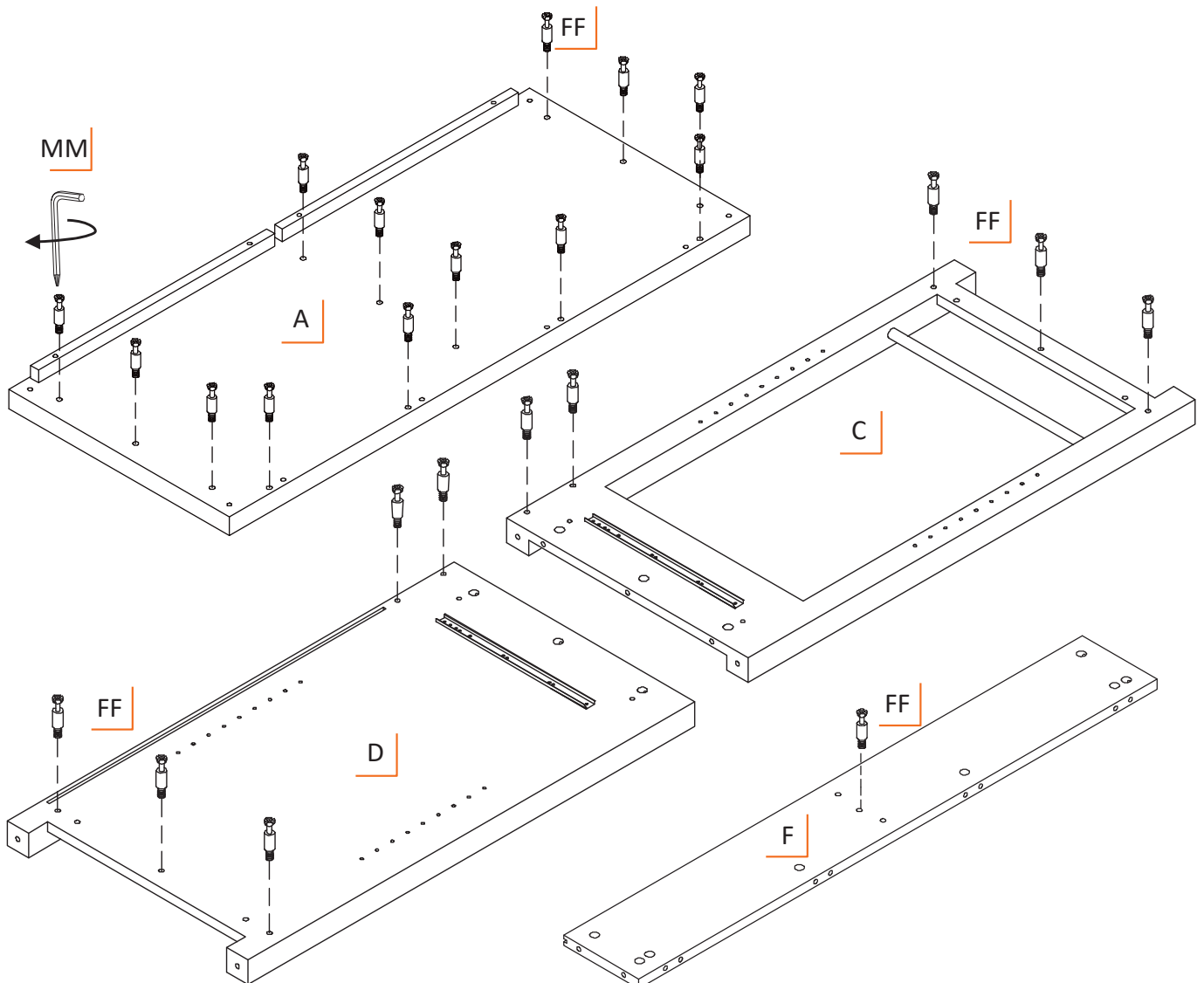

# ASSEMBLY INSTRUCTIONS

## STEP 2

Lay **BOTTOM SHELF (B)** on a clean surface with holes facing up. Insert (4) **DOWELS (HH)** into inner holes as shown.

Orient **LOWER SHELF FRAME (M)** with facing out. Align holes on **LOWER SHELF FRAME (M)** with **DOWELS (HH)** and push down onto **BOTTOM SHELF (B)**.

Insert (6) **SCREWS (EE)** through **LOWER SHELF FRAME (M)** and fasten tightly to **BOTTOM SHELF (B)** with **SCREWDRIVER (MM)**.

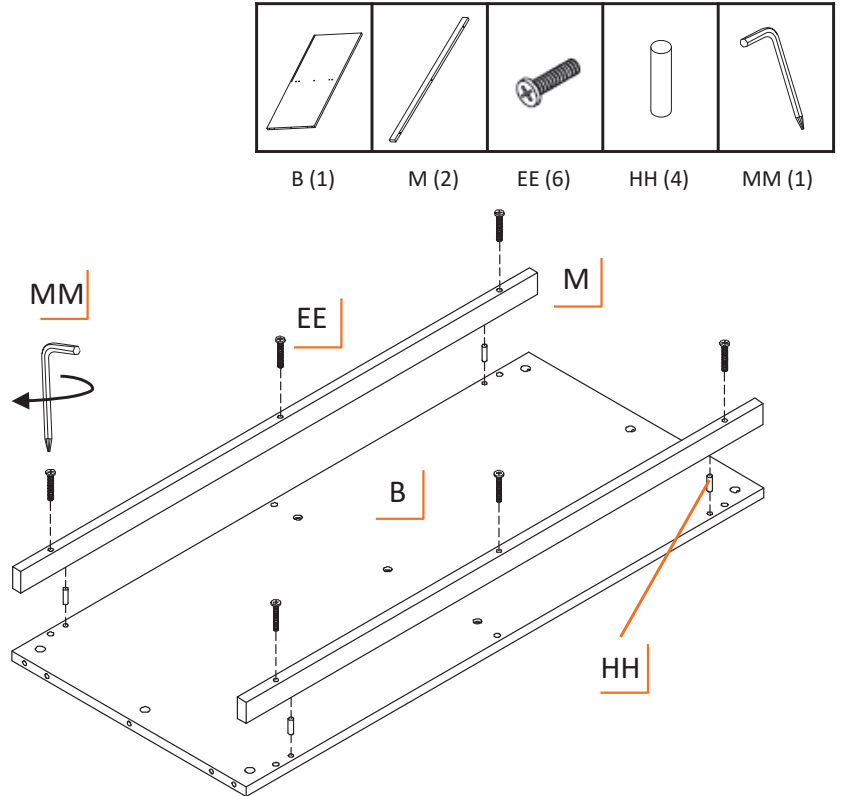

## STEP 3

Insert (2) **DOWELS (HH)** into center of **BACK FRAME (F)**. Connect **DIVIDER (E)** with **BACK FRAME (F)** via **DOWELS (HH)** and **CONNECTOR SCREW (FF)** as shown, making sure to align groove on **DIVIDER (E)** with groove on **BACK FRAME (F)**. Note groove on **BACK FRAME (F)** should face **DIVIDER (E)**.

Insert (1) **CAM LOCK (GG)** into **DIVIDER (E)** as shown with arrow on **CAM LOCK (GG)** pointing toward **BACK FRAME (F)**. Use **SCREWDRIVER (MM)** to turn **CAM LOCK (GG)** clockwise until **DIVIDER (E)** is pulled tight with **BACK FRAME (F)**.

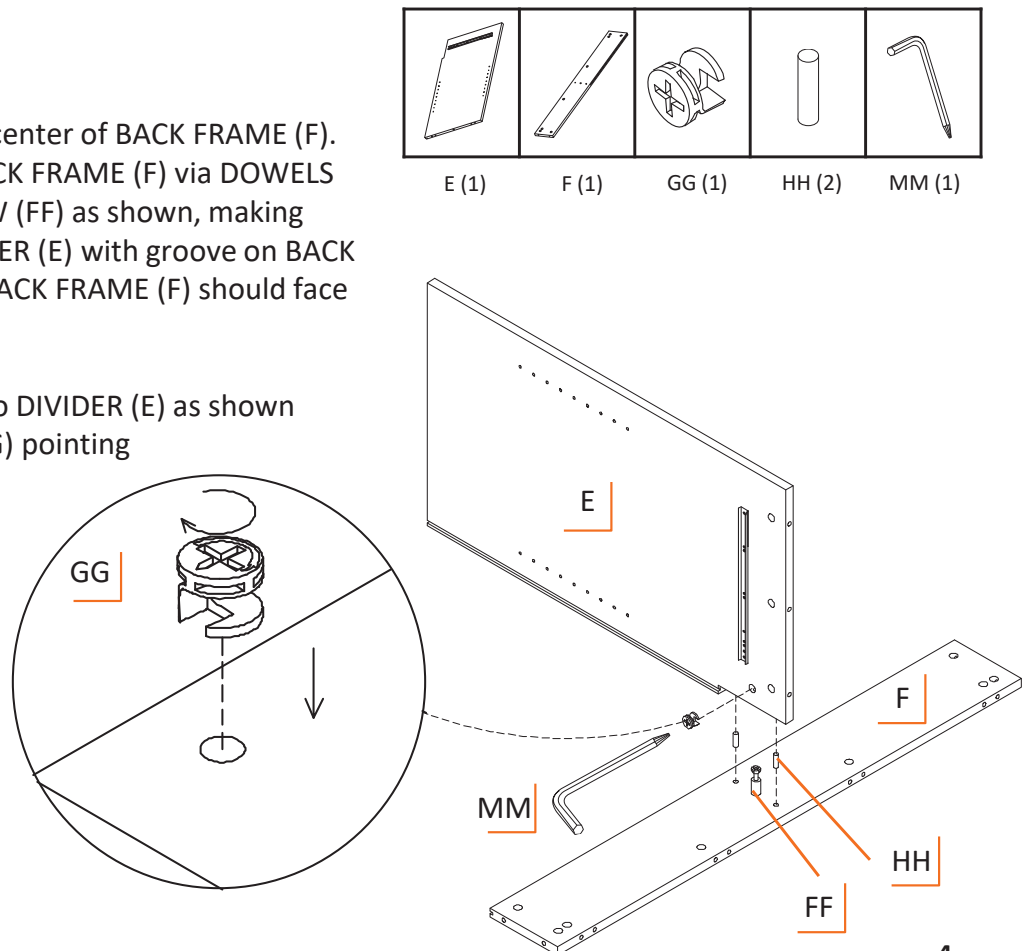

# ASSEMBLY INSTRUCTIONS

## STEP 4

Insert (2) DOWELS (HH) into bottom of DIVIDER (E) as shown. Connect DIVIDER (E) with BOTTOM SHELF (B) via inserted (2) DOWELS (HH), making sure to align grooves on BOTTOM SHELF (B), DIVIDER (E) and BACK FRAME (F).

Tightly fasten (3) SCREWS (EE) into center of BOTTOM SHELF (B) with SCREWDRIVER (MM).

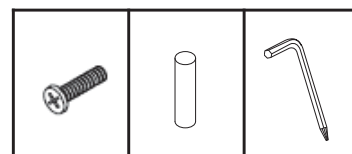

EE (3)    HH (2)    MM (1)

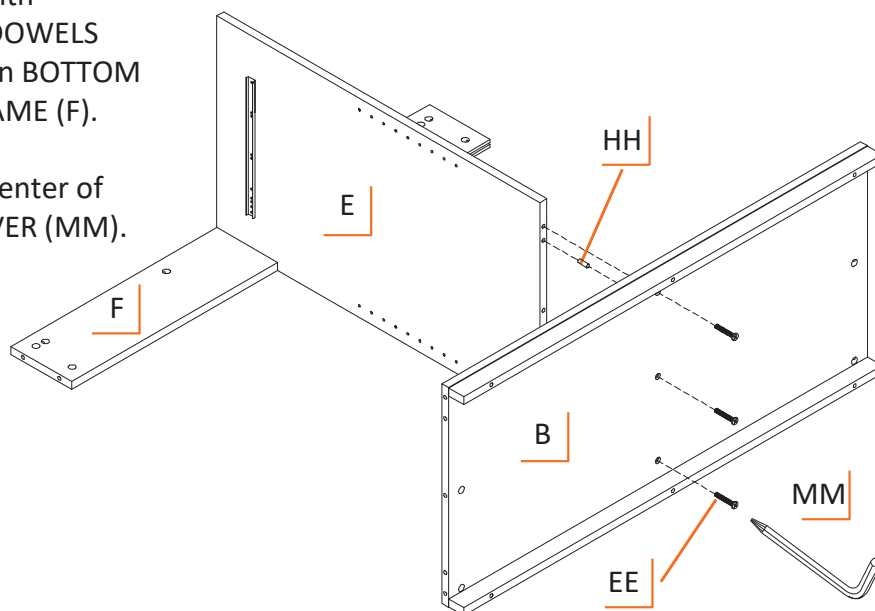

## STEP 5

Insert (1) CABINET BACK PANEL (G) through both grooves on BOTTOM SHELF (B) and BACK FRAME (F). Repeat with H SHAPE CONNECTOR (H) and remaining CABINET BACK PANEL (G) as shown.

Make sure to fully insert ends of panels and H shape connector completely inside grooves.

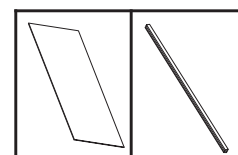

G (2)    H (1)

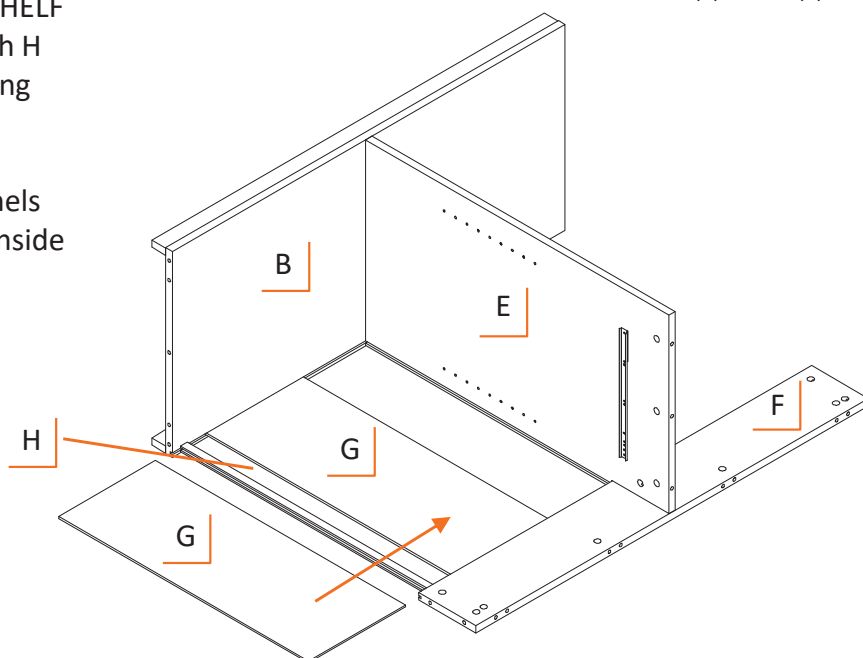

# ASSEMBLY INSTRUCTIONS

## STEP 6

Insert (2) DOWELS (HH) into each side of BOTTOM SHELF (B) as shown.

Connect LEFT SIDE FRAME (C) with BACK FRAME (F) and BOTTOM SHELF (B). Make sure all CONNECTOR SCREWS (FF) & DOWELS (HH) are inside corresponding holes.

Insert (2) CAM LOCKS (GG) into BACK FRAME (F) and (3) CAM LOCKS (GG) into BOTTOM SHELF (B) with arrow on CAM LOCK (GG) pointing toward LEFT SIDE FRAME (C).

Use SCREWDRIVER (MM) to turn CAM LOCKS (GG) clockwise until LEFT SIDE FRAME (C) is pulled tight with BACK FRAME (F) and BOTTOM SHELF (B).

Repeat to connect RIGHT SIDE FRAME (D).

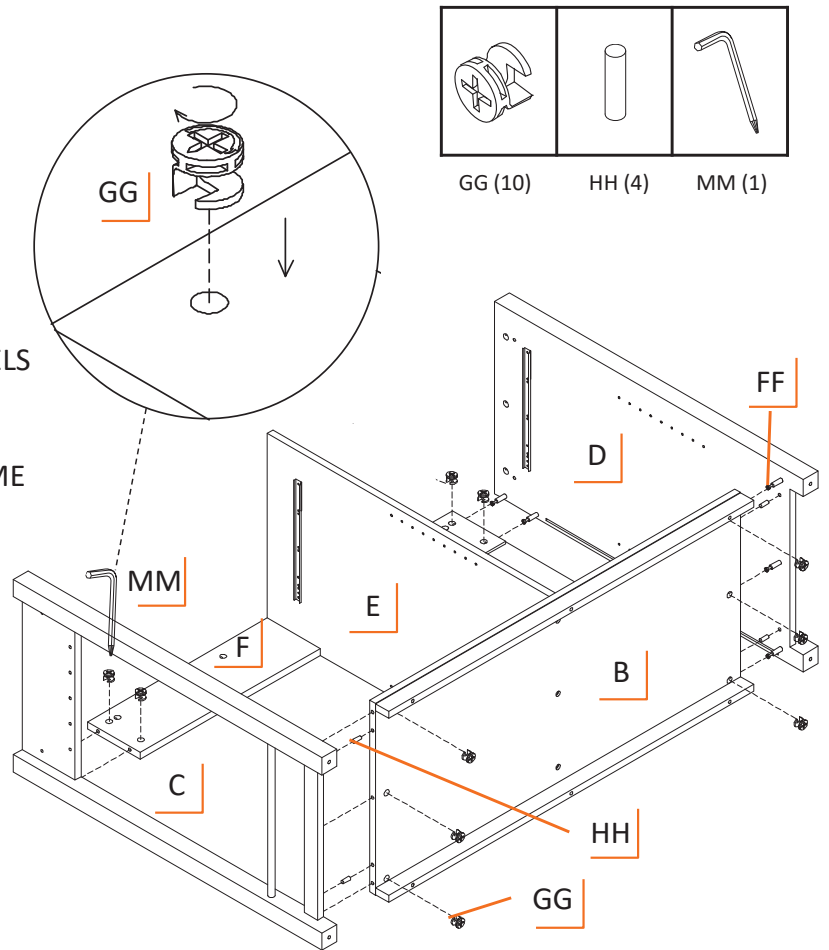

## STEP 7

Place (1) WASHER (JJ) over stem of each NON-LOCKING CASTERS (KK) and screw each into LEFT SIDE FRAME (C). Repeat with LOCKING CASTERS (LL) on RIGHT SIDE FRAME (D). Fully tighten casters with provided WRENCH (NN).

CASTERS can also be installed as desired, but you need to ensure (2) LOCKING CASTERS (LL) are on same side of Kitchen Island.

**Use provided caster wrench to tighten completely. Failure to do as instructed could result in caster stem breaking.**

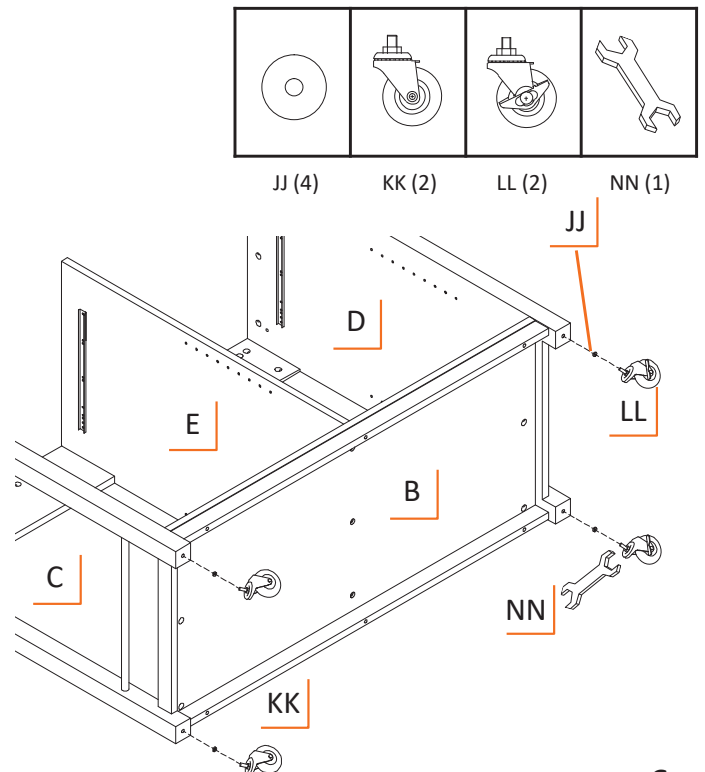

# ASSEMBLY INSTRUCTIONS

## STEP 8

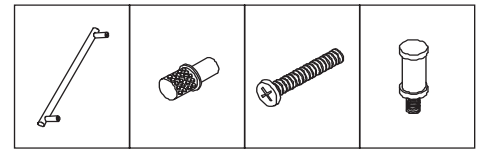

S (2) BB (9) CC (4) II (7)

With another person, carefully stand partially assembled Kitchen Island upright, making sure LOCKING CASTERS are locked.

Install (1) HANDLE (S) to LEFT SIDE FRAME (C) with (2) HANDLE SCREWS (CC) and tighten fully. Repeat for RIGHT SIDE FRAME (D).

Hand tighten (5) HANGER STUDS (II) on LEFT SIDE FRAME (C) and (2) HANGER STUDS (II) on RIGHT SIDE FRAME (D).

Insert (2) SHELF SUPPORT (BB) at desired heights on both LEFT and RIGHT SIDE FRAMES (C & D). Insert (4) SHELF SUPPORTS (BB), at same heights, on both sides of DIVIDER (E).

Make sure all (4) SHELF SUPPORTS (BB) are at same desired level where each shelf will be placed.

Insert (1) SHELF SUPPORT (BB) into lower front corner of DIVIDER (E) to act as a door stop for cabinet door.

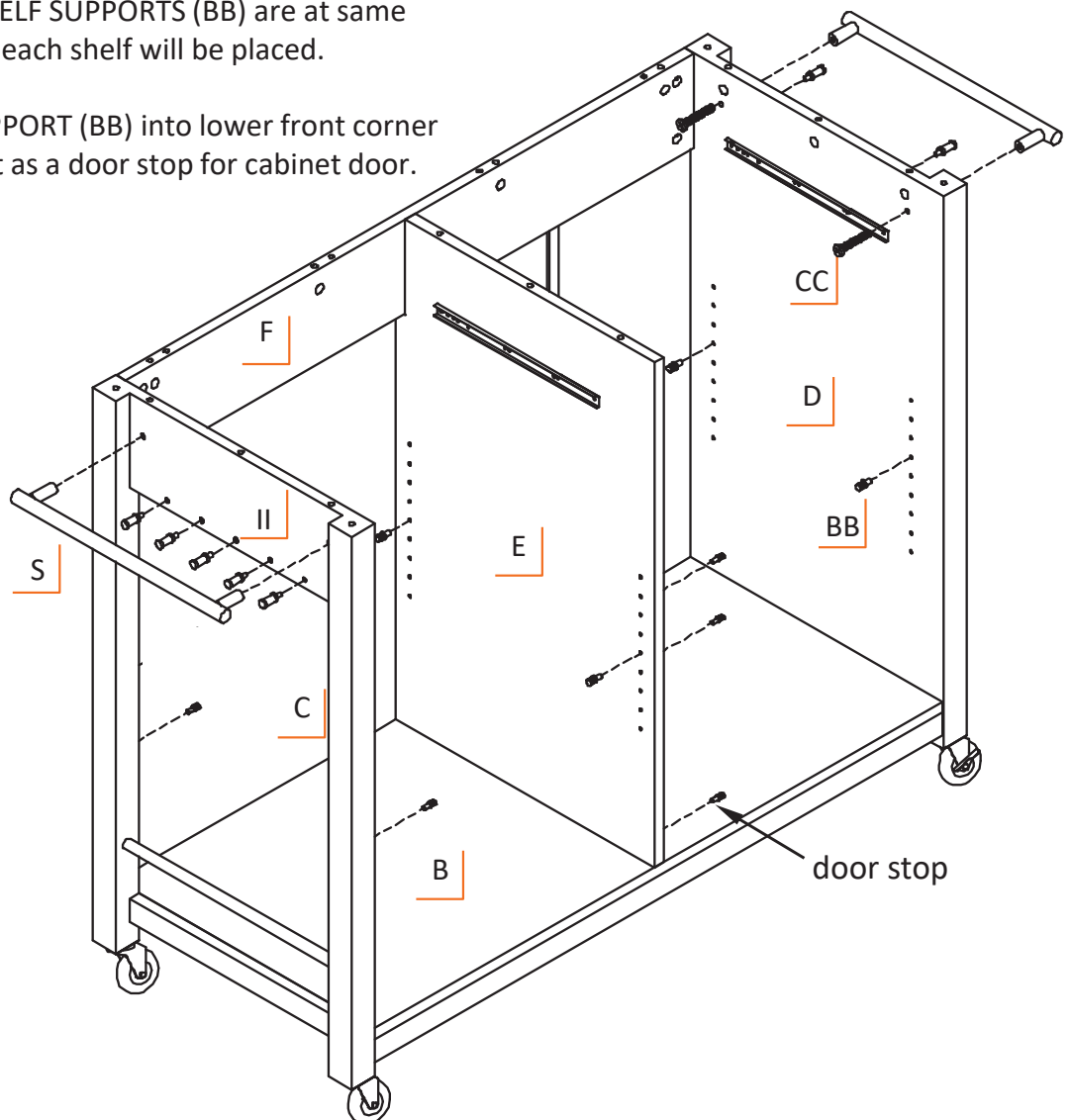

# ASSEMBLY INSTRUCTIONS

## STEP 9

Insert (4) DOWELS (HH) on each corner on top of LEFT and RIGHT SIDE FRAME (C & D). Insert (4) DOWELS (HH) into top of BACK FRAME (F) as shown.

With another person, lift TOP (A) and place onto Kitchen Island, making sure CONNECTOR SCREWS (FF) on TOP (A) and DOWELS (HH) go into corresponding holes.

Insert (13) CAM LOCKS (GG) into holes on LEFT SIDE FRAME (C), BACK FRAME (F), RIGHT SIDE FRAME (D), and DIVIDER (E), with arrow on CAM LOCK (GG) pointing up toward TOP (A).

Use SCREWDRIVER (MM) to turn all CAM LOCKS (GG) clockwise until TOP (A) is pulled tight with LEFT and RIGHT SIDE FRAMES (C & D), BACK FRAME (F) and DIVIDER (E).

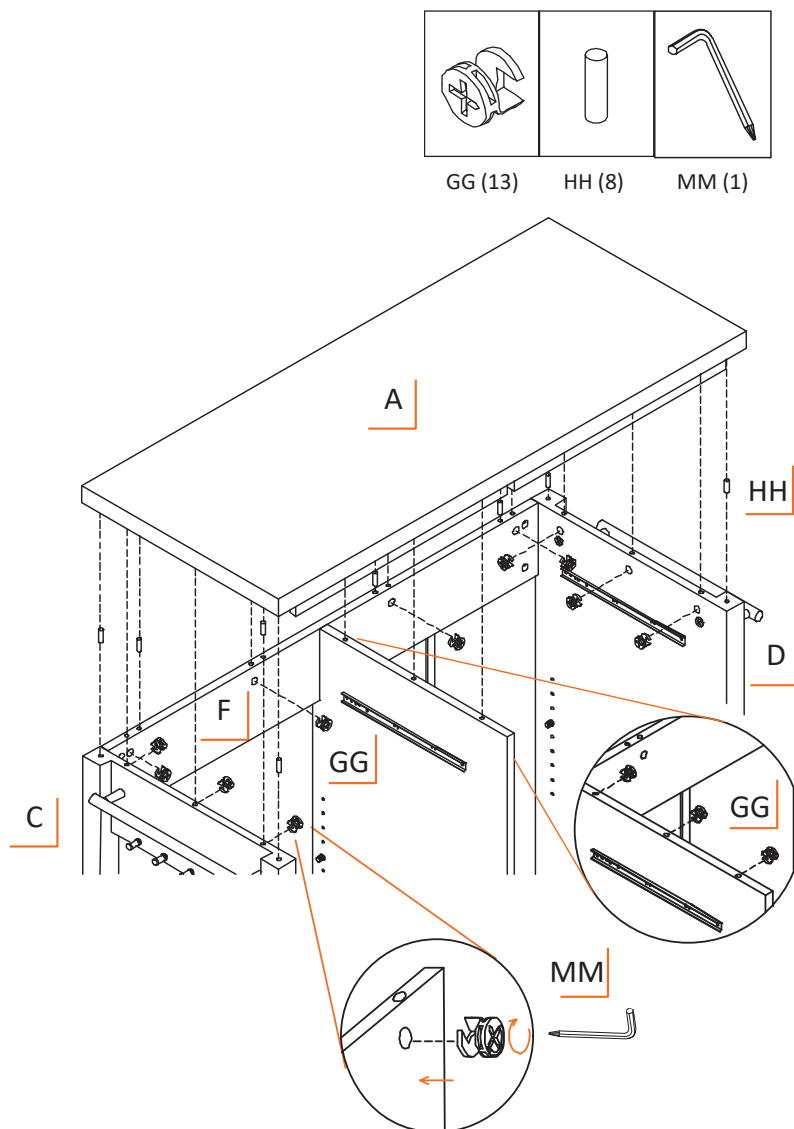

# ASSEMBLY INSTRUCTIONS

## STEP 10

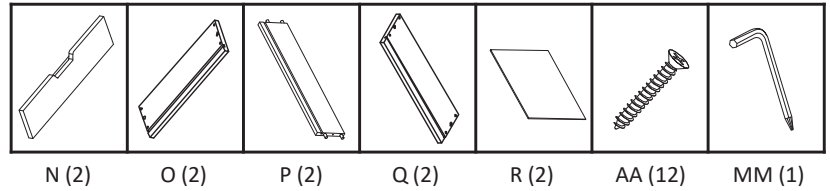

As shown in image 1, align and press dowels on DRAWER FRONT PANEL (N) and DRAWER BACK PANEL (P) into blind holes on DRAWER RIGHT PANEL (Q). Make sure grooves of all panels are aligned.

Insert (3) DRAWER SCREWS (AA) through DRAWER RIGHT PANEL (Q) and tightly fasten them with provided SCREWDRIVER (MM).

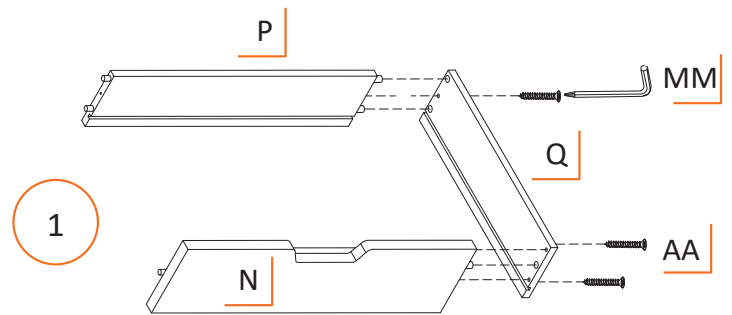

As shown in image 2, slide DRAWER BOTTOM PANEL (R) into grooves of assembled panels.

As shown in image 3, align and press dowels on DRAWER FRONT PANEL (N) and DRAWER BACK PANEL (P) into blind holes on DRAWER LEFT PANEL (O). Make sure all sides of DRAWER BOTTOM PANEL (R) are inside grooves.

Insert (3) DRAWER SCREWS (AA) through DRAWER LEFT PANEL (O) and tightly fasten them with provided SCREWDRIVER (MM).

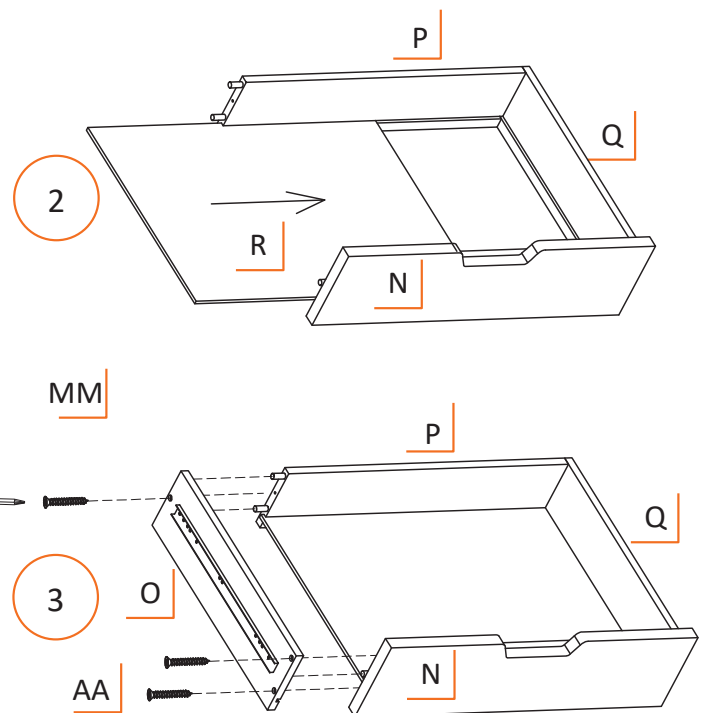

As shown in image 4, a fully assembled Kitchen Island drawer.

Repeat to assemble other drawer.

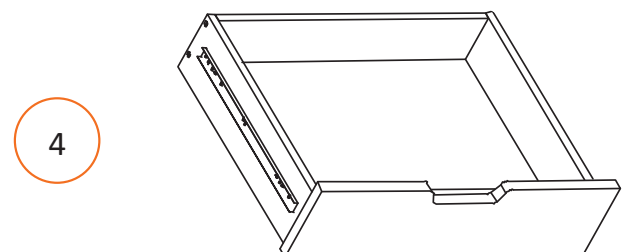

# ASSEMBLY INSTRUCTIONS

## STEP 11

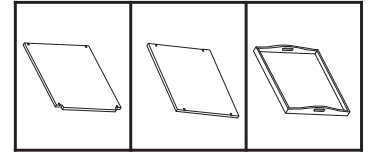

I (1)

J (1)

K (1)

As shown in image:

Pull out slides on left side frame and divider and align them with slides on one assembled drawer. Push drawer fully into Kitchen Island. Repeat to assemble other drawer to Kitchen Island.

Place SHELF (I) onto SHELF SUPPORTS (BB) that were inserted at STEP 8 on left hand side. Then place TRAY (K) onto SHELF (I).

Place CABINET SHELF (J) onto SHELF SUPPORTS (BB) on right hand side.

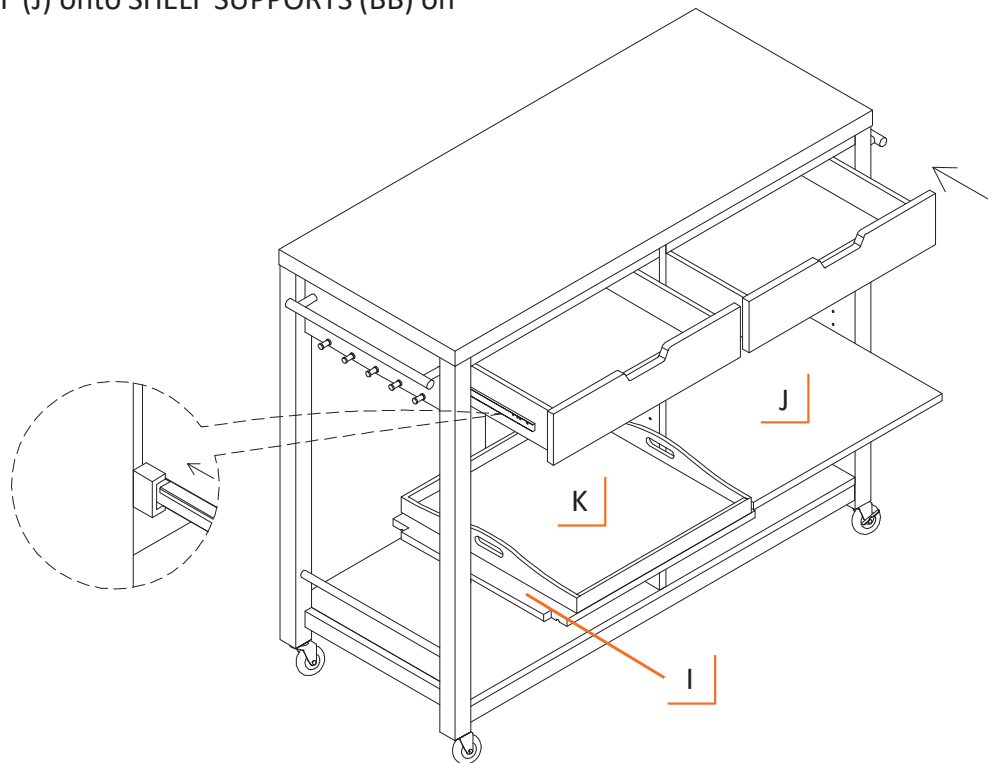

# ASSEMBLY INSTRUCTIONS

## STEP 12

Place DOOR PANEL (L) on a clean surface with 2 circular pockets facing up. As shown in the image, take HINGE (T) and fit one side into circular pocket.

Screw (2) HINGE SCREWS (DD) through HINGE (T) into DOOR PANEL (L). Fasten screws with SCREWDRIVER (MM). Repeat to fasten remaining HINGE (T) to DOOR PANEL (L).

With one person holding DOOR PANEL (L), align HINGE (T) with screw holes in cabinet where hinges are to be installed.

A second person screws (4) HINGE SCREWS (DD) through each HINGE (T) into RIGHT SIDE PANEL (D).

Close DOOR PANEL (L) to complete assembly.

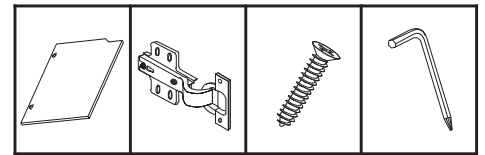

L (1) T (2) DD (12) MM (1)

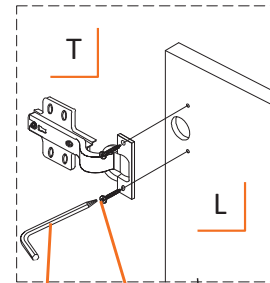

MM DD

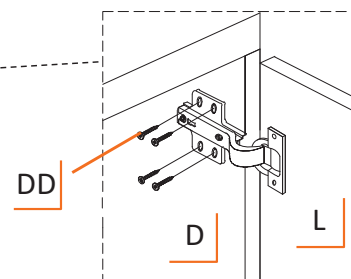
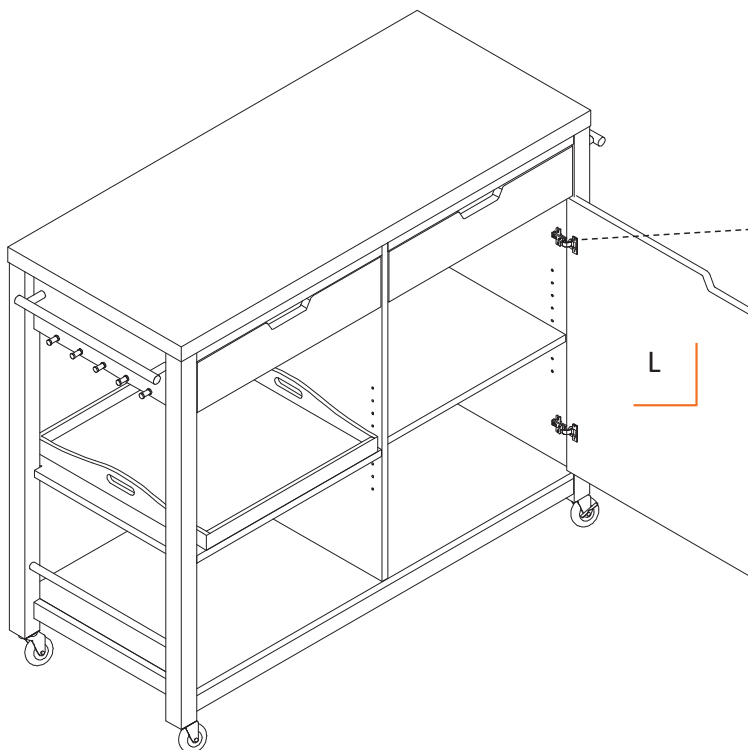
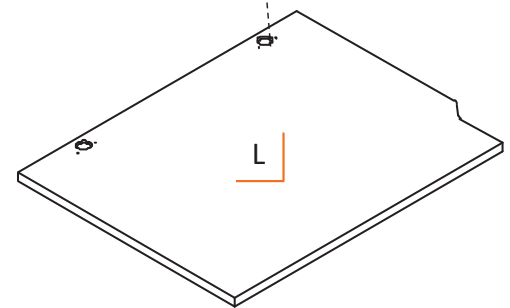

# USAGE INSTRUCTIONS

## Adjusting SHELF Position

Reposition SHELF SUPPORTS (BB) at desired heights up and down along holes of LEFT SIDE FRAME (C), RIGHT SIDE FRAME (D) and DIVIDER (E). SHELF (I) and CABINET SHELF (J) can now move up and down accordingly.

