

PARTS LIST

Your 72"x24"x72" Wire Shelving Rack should include the following parts. Please inspect box contents to ensure you have received all components.

You will NOT need additional tools for assembly.

A

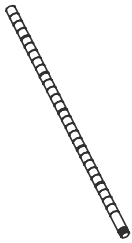

BOTTOM POLE (4)
Threaded Insert (4) and
Feet Leveler (4)
pre-installed

B

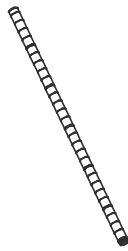

TOP POLE (4)
End Cap (4) and
pole connector (4)
pre-installed

C

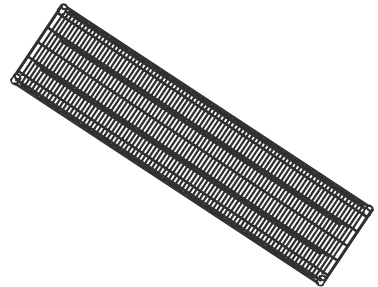

SHELF (5)

D



SLIP SLEEVE
(40) + (2) extra

E

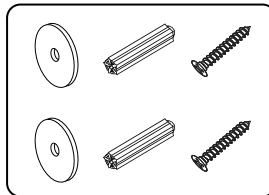

**ANTI-TIP
HARDWARE
PACK (1)**



Note: The black circular plastic spacers in between Shelves are used only for packaging purposes. They are NOT needed. Please discard.

ASSEMBLY INSTRUCTIONS

STEP 1

For easiest assembly, do not attach TOP POLES (B) and BOTTOM POLES (A) until instructed. Once connected, these will be posts for the rack.

Note that POLES (A+B) have slight horizontal line indentations at 1" intervals. Each SLIP SLEEVE (D) has raised horizontal lines inside designed to lock them in place on POLES (A+B).

On BOTTOM POLE (A), place one pair of SLIP SLEEVES (D) at desired height no higher than 3rd indentation from bottom. Make sure arrow faces up and word "TOP" is right side up.

Slide pair of SLIP SLEEVES (D) until you hear a click to confirm the pair is locked onto BOTTOM POLE (A). Do this for each BOTTOM POLE (A) and make sure height is identical for each BOTTOM POLE (A). Do NOT place more than one pair on each pole at a time.

Note: There will be a very small gap in-between two locked SLIP SLEEVES (D)—this is normal.

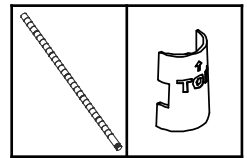

A (4) D (8)

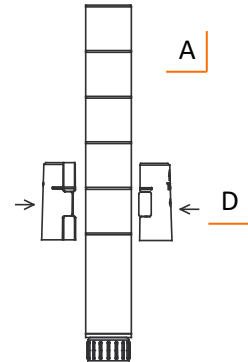

STEP 2

Place SHELF (C) on its side and slide each BOTTOM POLE (A) through each corner cylinder on SHELF (C). Make sure SHELF (C) corner cylinders are positioned over SLIP SLEEVES (D).

Stand the unit upright.

Note:

- Level side of SHELF (C) is TOP side (PRO logo on corner cylinders should be right-side up.)
- Use a rubber mallet, if needed, to secure SHELF (C).

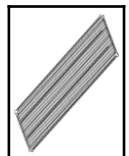

C (1)

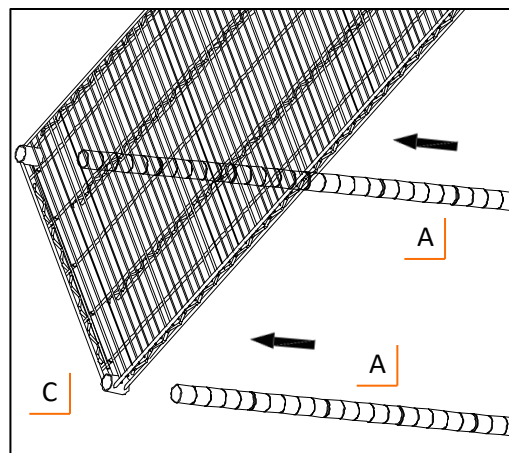

ASSEMBLY INSTRUCTIONS

STEP 3

On BOTTOM POLE (A), place 1 pair of SLIP SLEEVES (D) at desired height. Make sure arrow faces up and word "TOP" is right side up. Do this for each BOTTOM POLE (A), and make sure height is identical for each BOTTOM POLE (A).

Lower SHELF (C) over each BOTTOM POLE (A) so corner cylinders of SHELF (C) are positioned over SLIP SLEEVES (D).

Note:

- Shelves are adjustable in 1" increments and can be placed as needed to best fit storage needs.
- Use a rubber mallet, if needed, to secure SHELF (C).

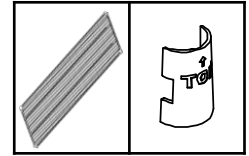

C (1)

D (8)

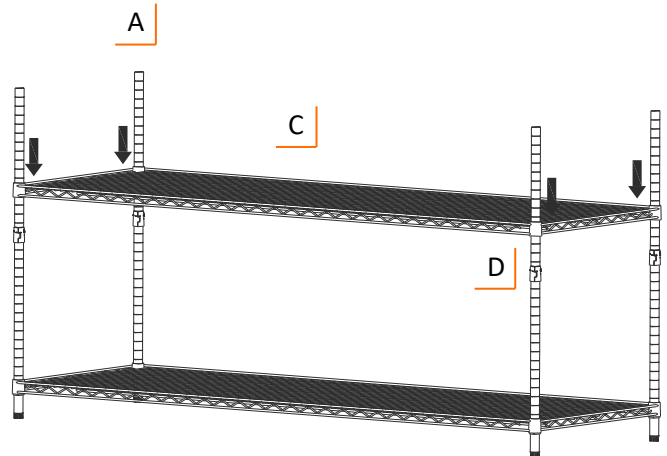

STEP 4

Screw TOP POLE (B) into BOTTOM POLE (A).

Repeat for each remaining TOP POLE (B).

Note: Top of each TOP POLE (B) is indicated by a BLACK END CAP.

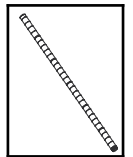

B (4)

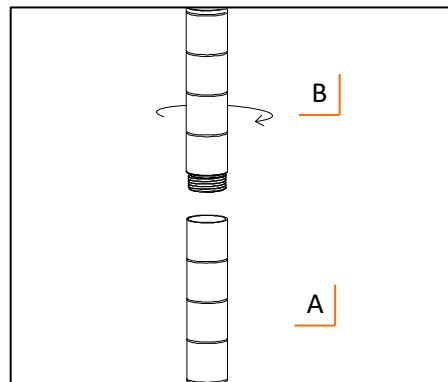

ASSEMBLY INSTRUCTIONS

STEP 5

Repeat Step 3 to install other SHELVES (C) as desired.

Note:

- Shelves are adjustable in 1" increments and can be placed as needed to best fit storage needs.
- Use a rubber mallet, if needed, to secure SHELVES (C).

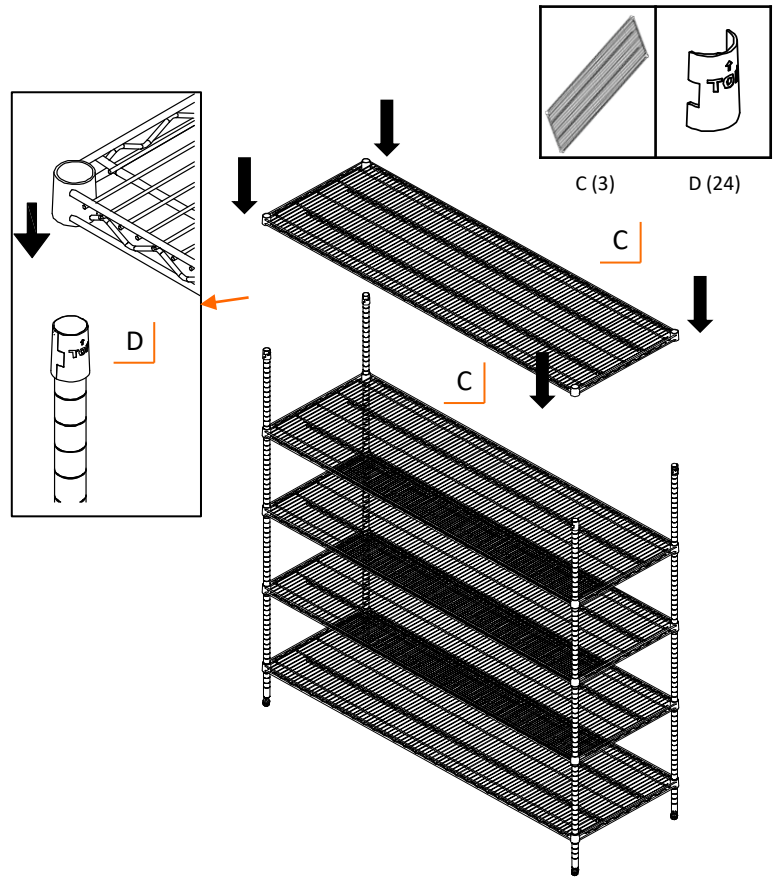

STEP 6

Adjust FEET LEVELERS as needed to ensure shelving rack is level.

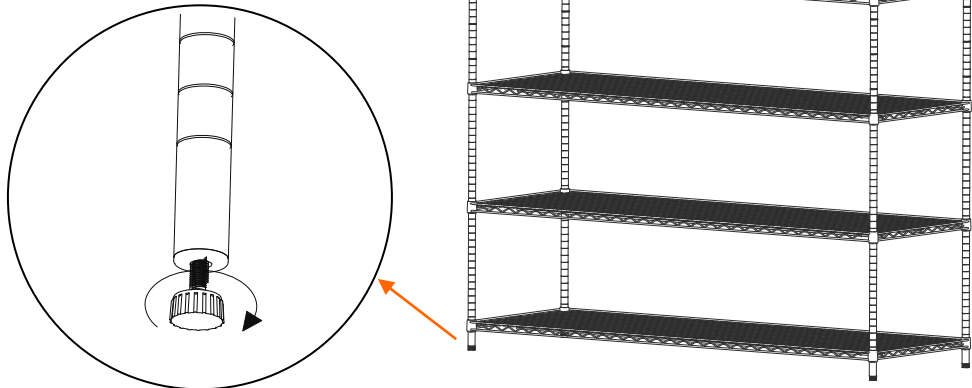

ASSEMBLY INSTRUCTIONS

Anti-tip Hardware Installation

ANTI-TIP HARDWARE PACK (E) is used to protect against accidental tipping – especially due to curious children.

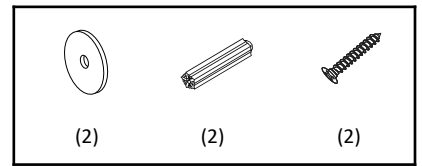

E (1)

On Wood Stud

Determine wood stud location and mark it on wall, level with topmost shelf. Do this on two different studs along top shelf.

Place Shelving Rack into position.

Insert Screw through Washer and backside frame of top shelf as shown. Fasten Screw tightly into stud. Do this for each stud that was marked out.

On Brick/Concrete

Mark out two separate locations on wall, level with topmost shelf.

With a 1/4" drill bit, drill a hole 1-1/4" deep at each marked location. Push Anchors flush into each hole.

Place Shelving Rack into position.

Insert Screw through Washer and backside frame of top shelf as shown. Fasten Screw tightly into Anchor. Do this on both Anchors that were placed in wall.

