

# Assembly Instruction

Note:

1. Should be assembled on flat ground to keep balance.
2. Before completing the installation, do not tighten the screws.

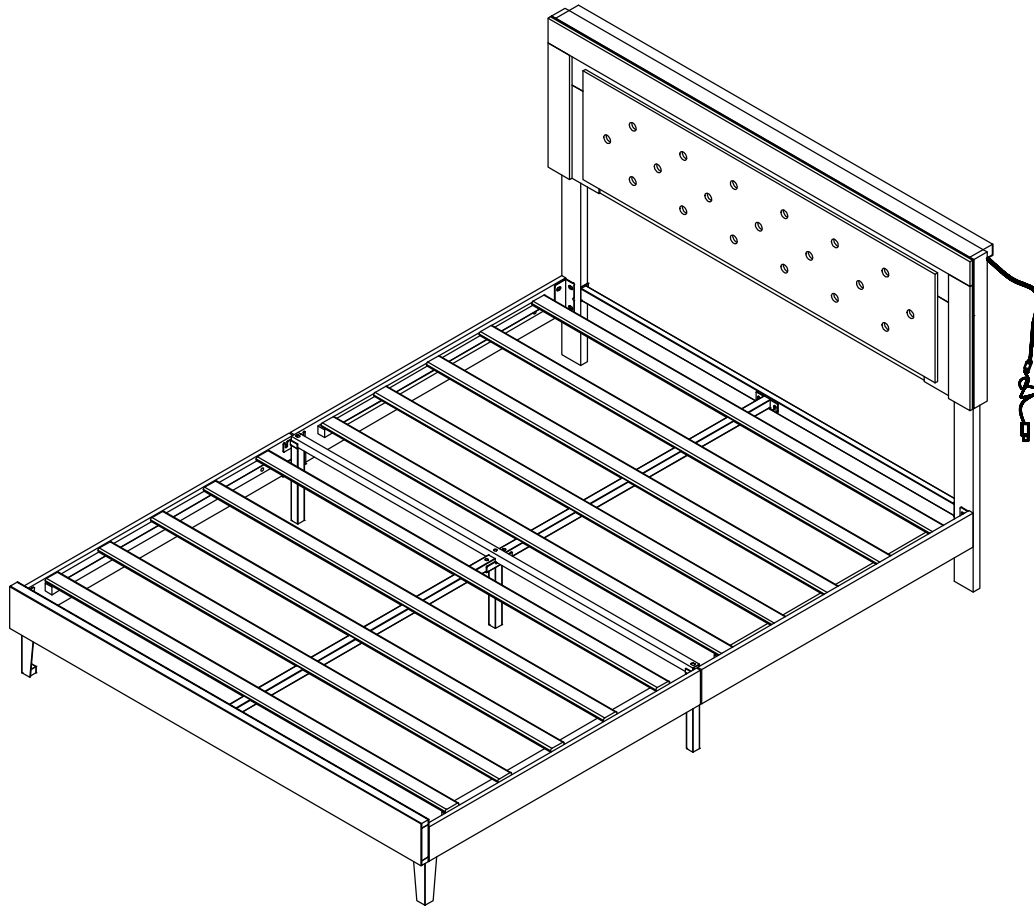

It needs at least two people to install.



Before starting the assembly, you must read the whole manual and follow the instructions.

# Assembly Instruction

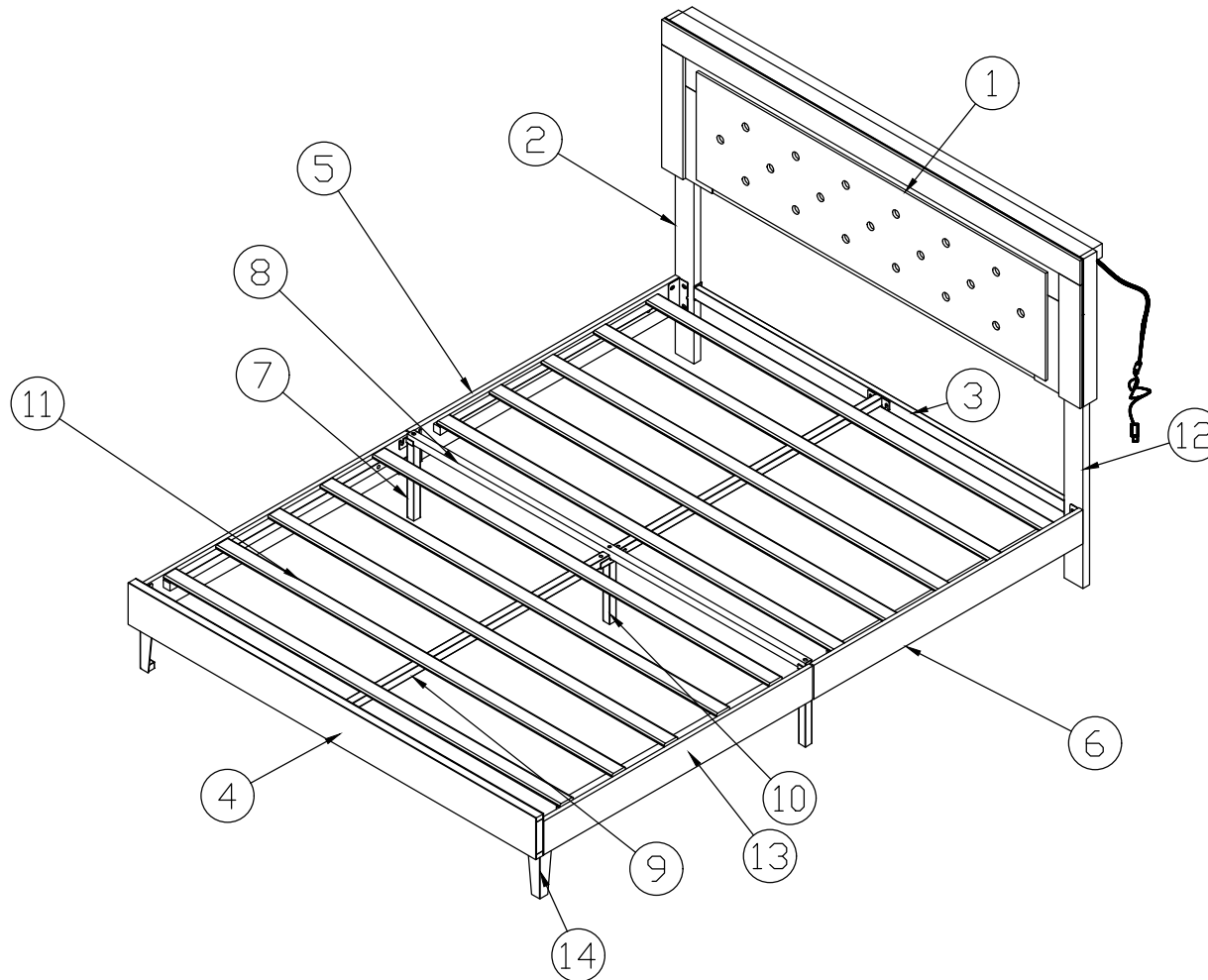



# Assembly Instruction

## Hardware Parts

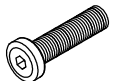
  
 Ⓐ M8x20  
 26pcs

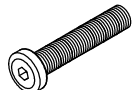
  
 Ⓑ M8x35  
 4pcs

  
 Ⓒ M8x40  
 4pcs

  
 Ⓓ 4 #  
 1pc

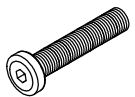
  
 Ⓔ M8x50  
 1pc

## Part list

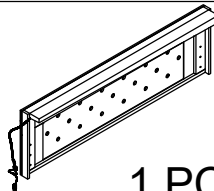
①   
 1 PC

②   
 1 PC

③   
 1 PC

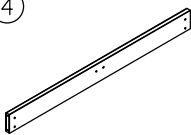
④   
 1 PC

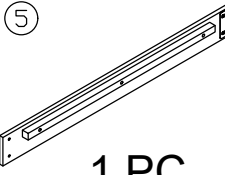
⑤   
 1 PC

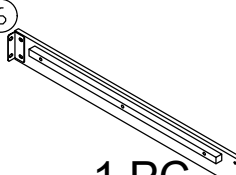
⑥   
 1 PC

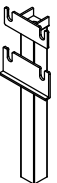
⑦   
 2 PCS

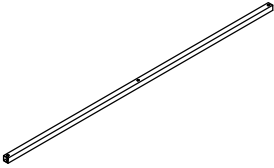
⑧   
 1 PC

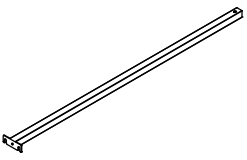
⑨   
 2 PCS

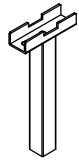
⑩   
 1 PC

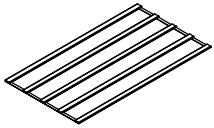

⑪   
 2 PCS

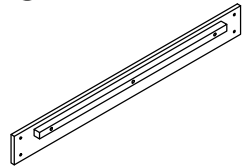
⑫   
 1 PC



⑬   
 2 PCS

⑭   
 2 PCS

# Assembly Instruction

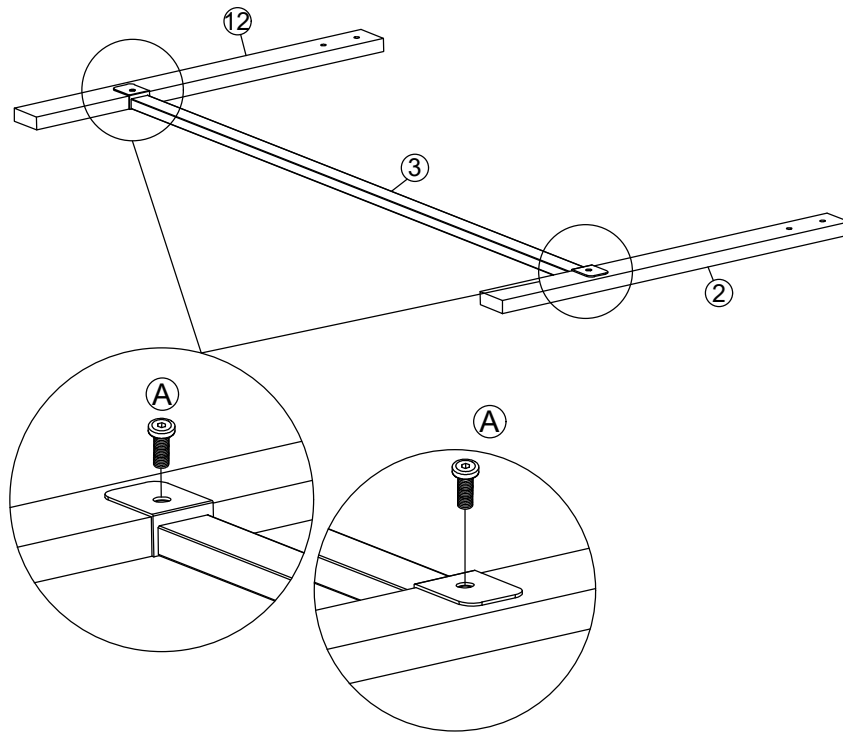

A	 M8*20	2 pcs
D		1 pc



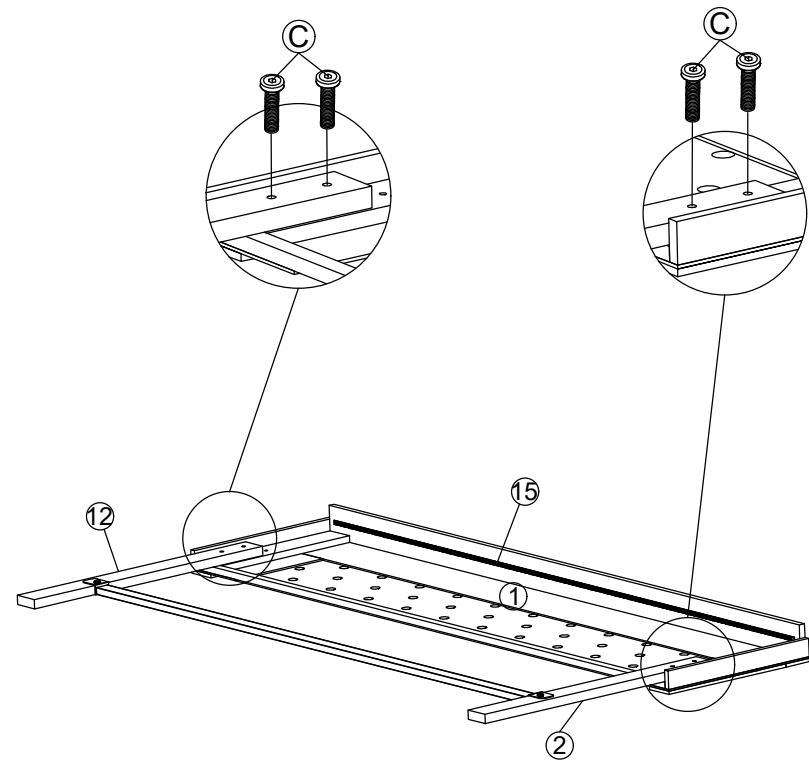

C	 M8*40	4 pcs
D		1 pc

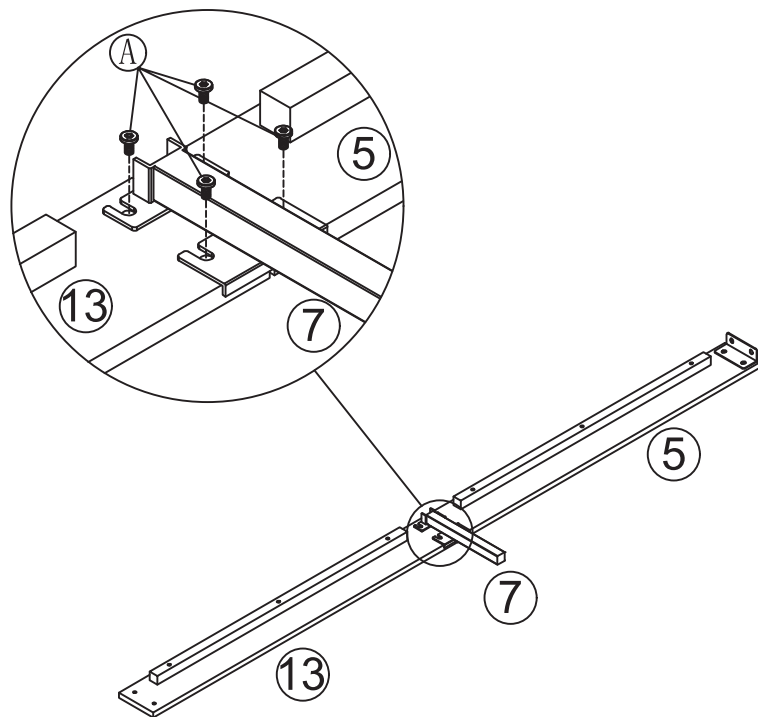

# Assembly Instruction

A	 M8x20	4pcs
D		1pc



A	 M8x20	2pcs
D		1pc

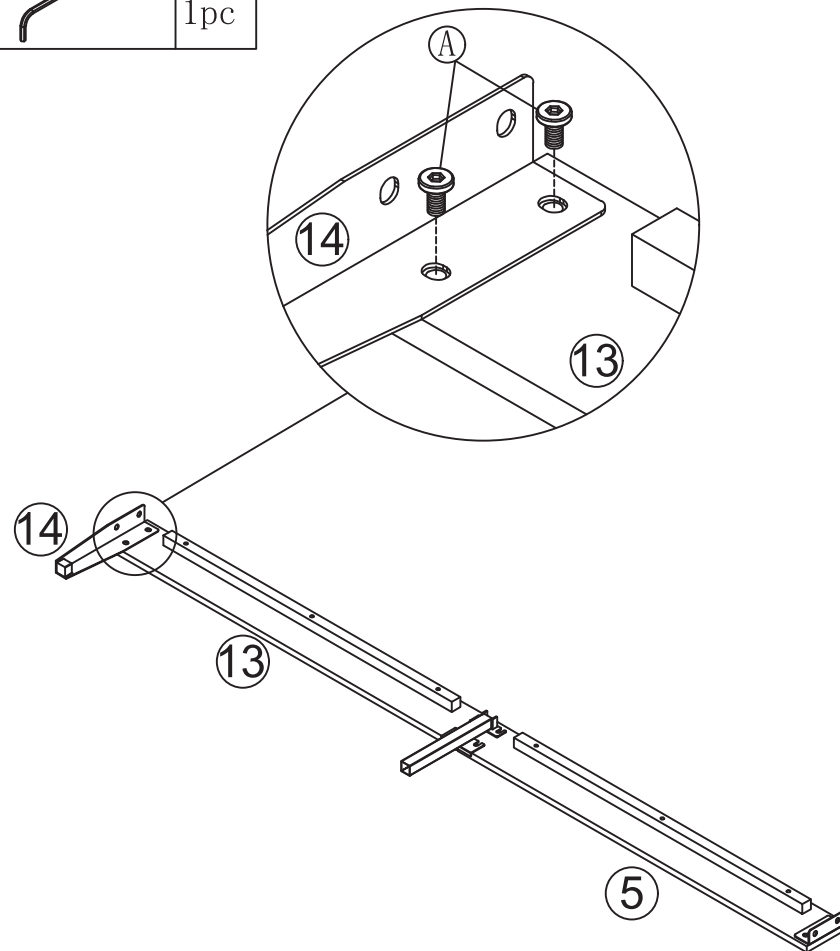

# Assembly Instruction

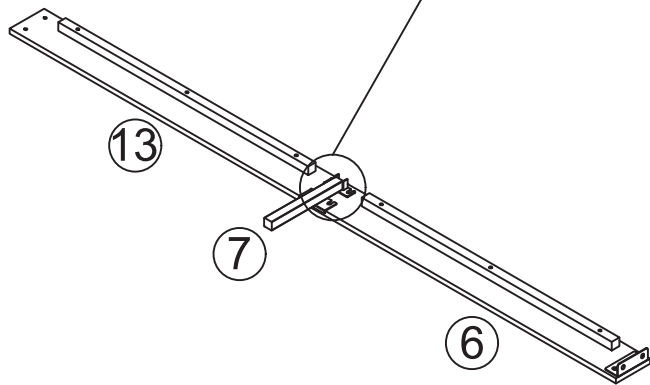
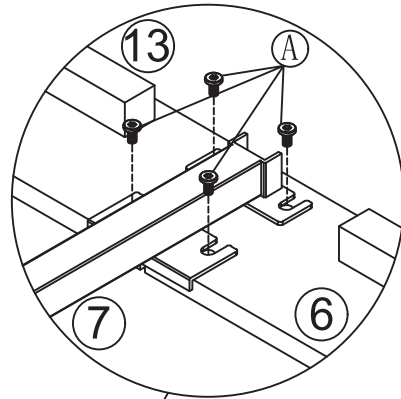

A	 M8x20	4pcs
D		1pc



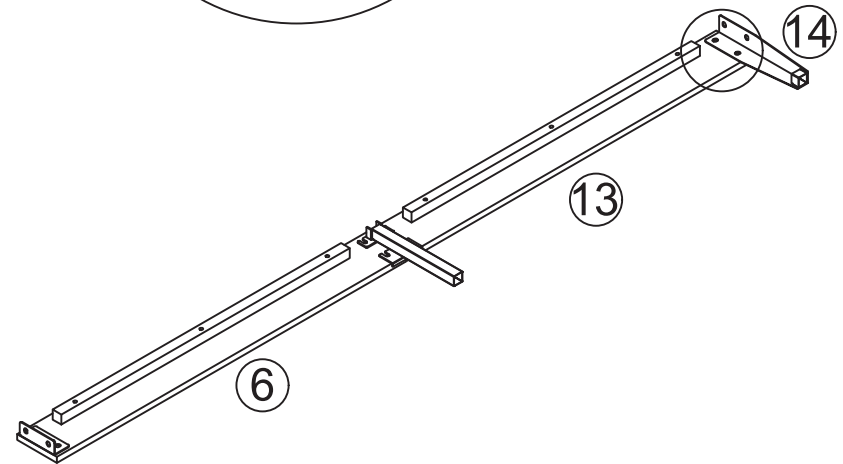
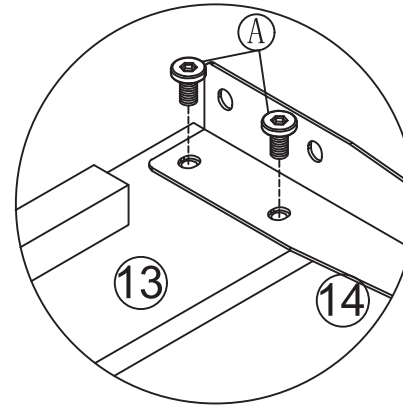

A	 M8x20	2pcs
D		1pc



# Assembly Instruction

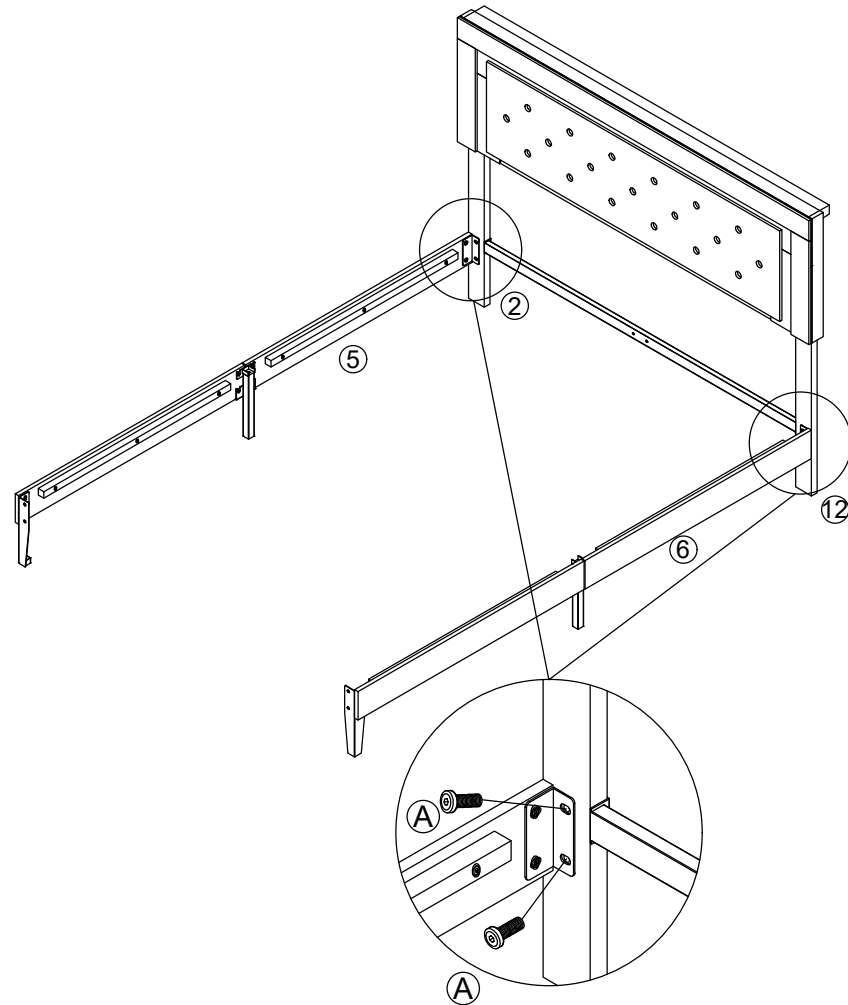

A	 M8*20	4 pcs
D		1 pc



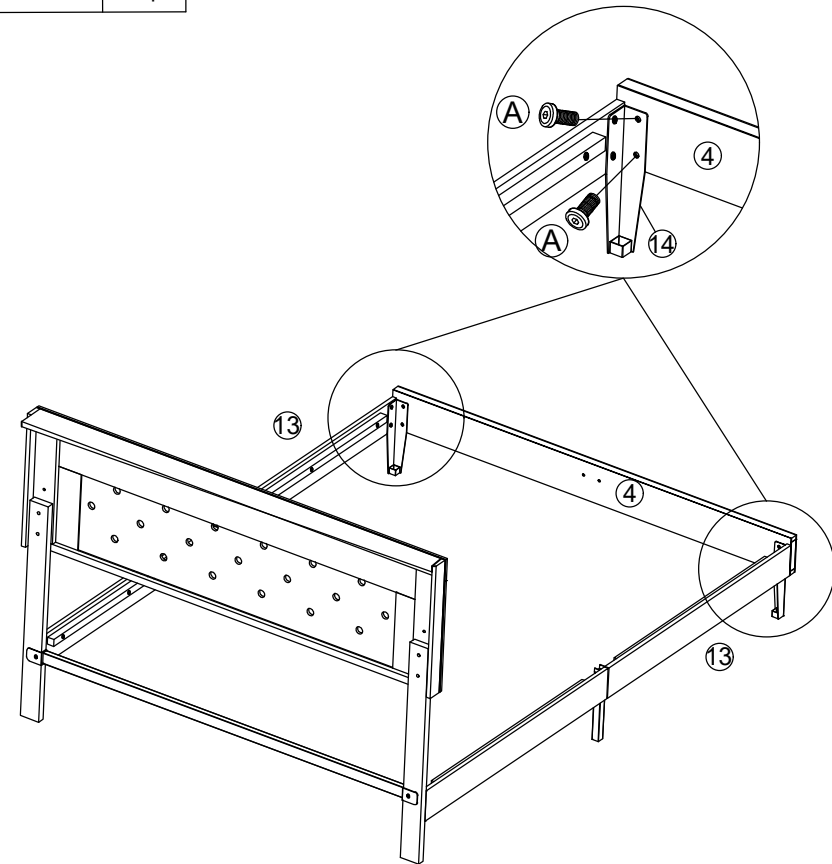

A	 M8*20	4 pcs
D		1 pc



# Assembly Instruction

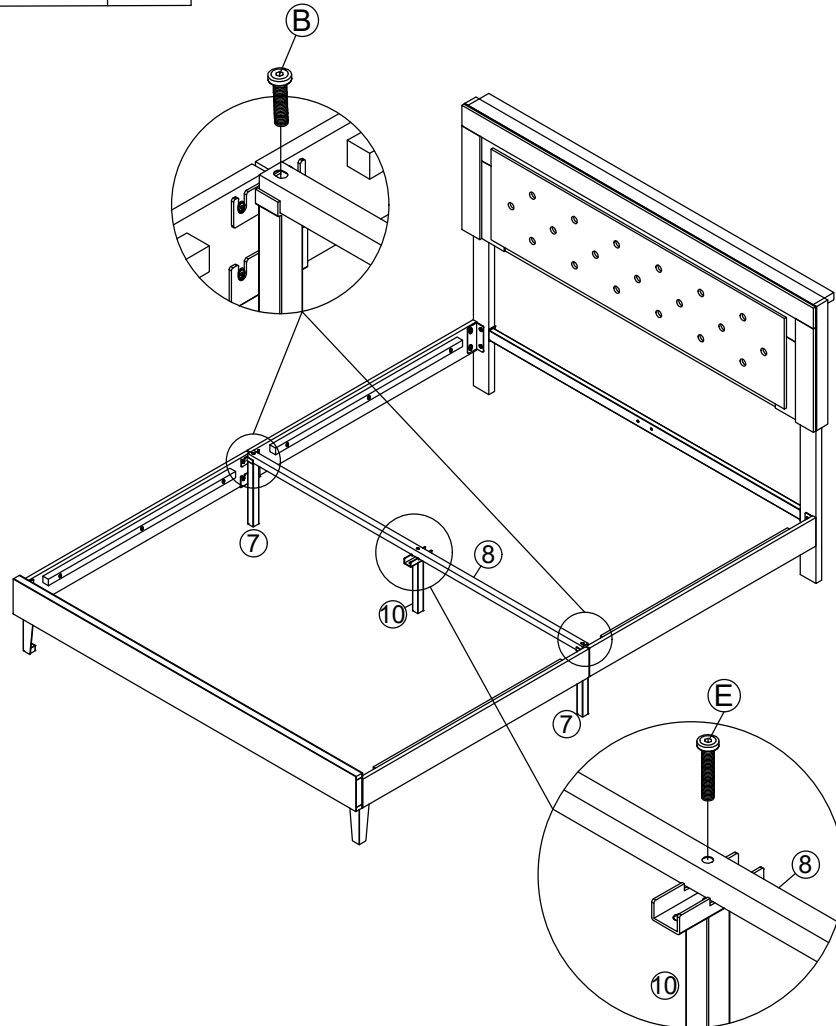

B	 M8*35	2 pcs	E	 M8*50	1 pc
D		1 pc			

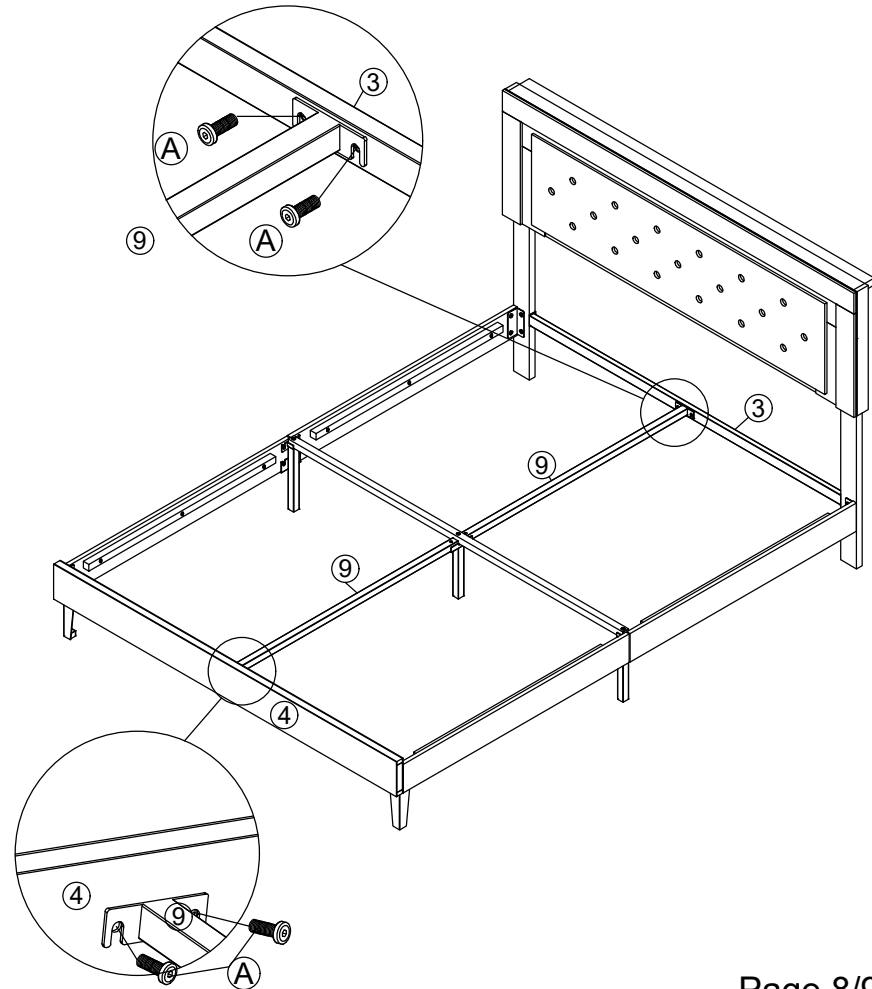

A	 M8*20	4 pcs
D		1 pc



# Assembly Instruction

B	 M8*35	2 pcs
D		1 pc

