

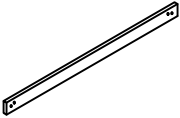

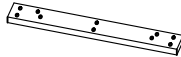

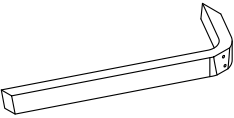

Product Assembly Instructions

PART LIST

 <p>A : TABLE TOP x1</p>	 <p>B : TABLE LEG SUPPORT x1</p>	 <p>C : CENTER SUPPORT x2</p>
 <p>D : TABLE LEG (L&R) x4</p>		

HARDWARE LIST

 <p>E : JCBC SCREW M6 X 40MM (BLK) x8</p>	 <p>F : JCBC SCREW M6 X 30MM x16</p>	 <p>G : SPRING WASHER 1/4" (BLK) x8</p>
 <p>H : SPRING WASHER 1/4" x16</p>	 <p>I : ALLEN KEY M4 (BALL SHAPE)LONG x1</p>	

STEP 1

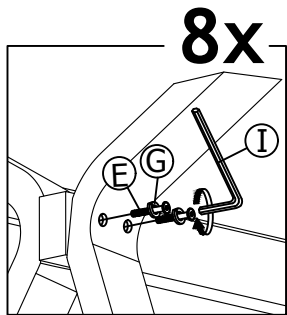

Remark : Do Not Fully Tighten

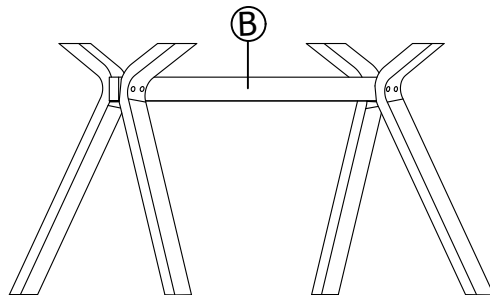

STEP 2

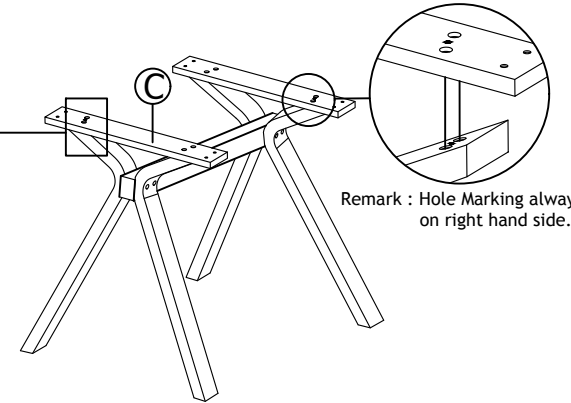
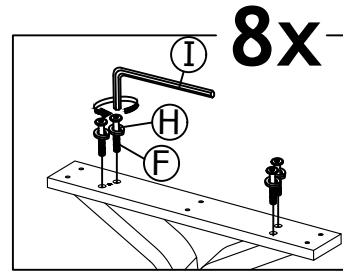

Remark : Hole Marking always on right hand side.

STEP 3

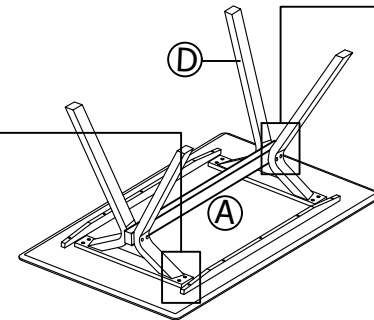
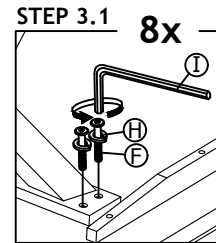

STEP 3.2

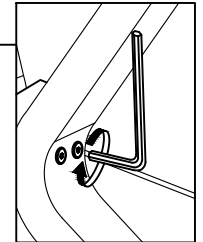

Remark : Remember Tighten Fully

STEP 4

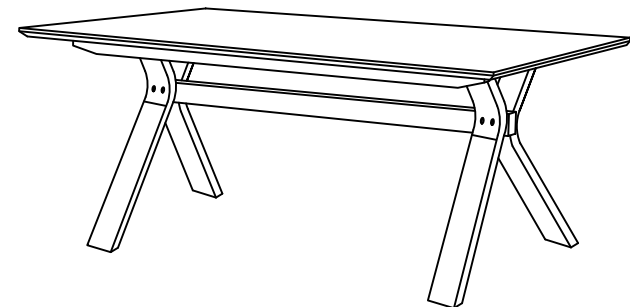

COMPLETED ASSEMBLY