

ASSEMBLY INSTRUCTIONS

MODEL# : F2604

**KEEP THIS DOCUMENT FOR REFERENCE IN CASE PARTS ARE NEEDED
DO NOT TIGHTEN SCREWS UNTIL COMPLETELY ASSEMBLED !**

No.	DESCRIPTION	Q'TY	No.	DESCRIPTION	Q'TY
A	TABLE TOP	1pc	1	BOLT(5/16"x2-1/2")	8pcs
B	TABLE LEG	4pcs	2	BOLT(5/16"x1-1/4")	16pcs
C	TABLE BASE PANEL	4pcs	3	SPRING WASHER(5/16")	24pcs
D	FLOOR FRAME	2pcs	4	METAL WASHER(5/16")	24pcs
E	CHAIR BACK	4pcs	5	ALLEN KEY	1pc
F	CHAIR SEAT	4pcs	6	BOLT(1/4"x3-1/8")	16pcs
G	CHAIR LEFT LEG	4pcs	7	BOLT(1/4"x2-3/8")	16pcs
H	CHAIR RIGHT LEG	4pcs	8	BOLT(1/4"x1-1/2")	8pcs
I	CHAIR LEFT STRETCHER	4pcs	9	SPRING WASHER(1/4")	40pcs
J	CHAIR RIGHT STRETCHER	4pcs	10	METAL WASHER(1/4")	40pcs
K	CHAIR FRONT STRETCHER	4pcs	11	WOOD SCREW(M4x38mm)	24pcs

STEP 1

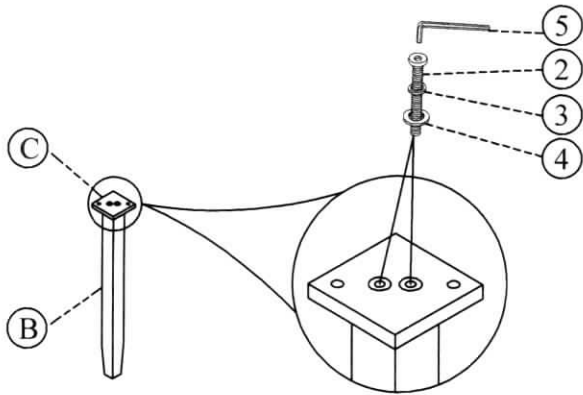

STEP 2

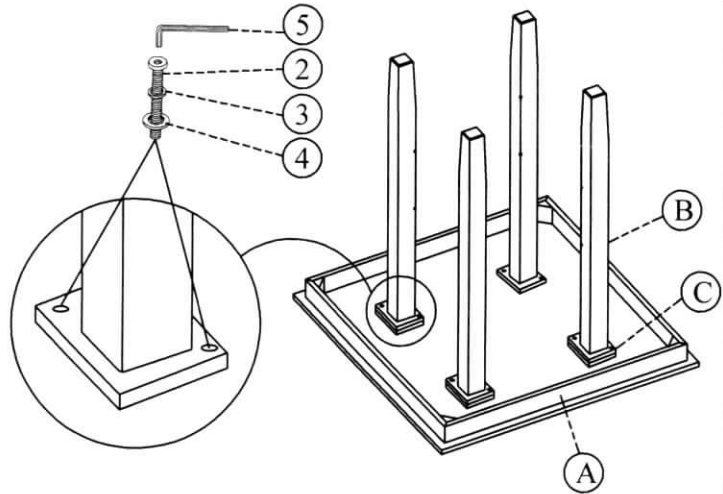

STEP 3

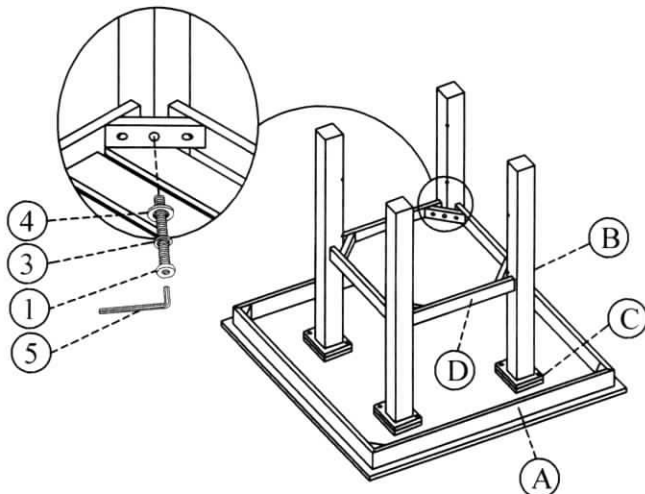

STEP 4

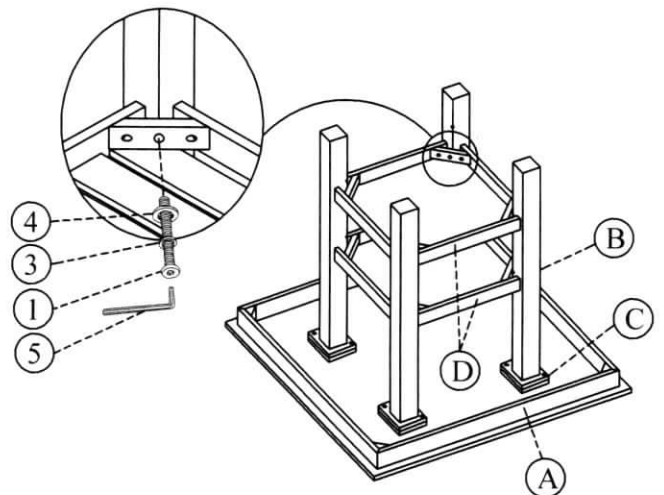

ASSEMBLY INSTRUCTIONS

MODEL# : F2604

**KEEP THIS DOCUMENT FOR REFERENCE IN CASE PARTS ARE NEEDED
DO NOT TIGHTEN SCREWS UNTIL COMPLETELY ASSEMBLED !**

STEP 5

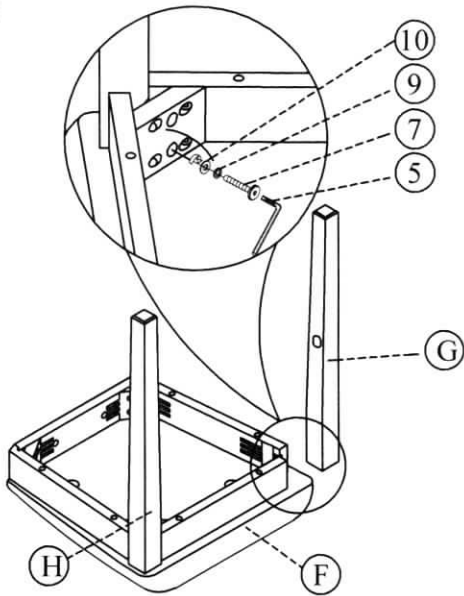

STEP 6

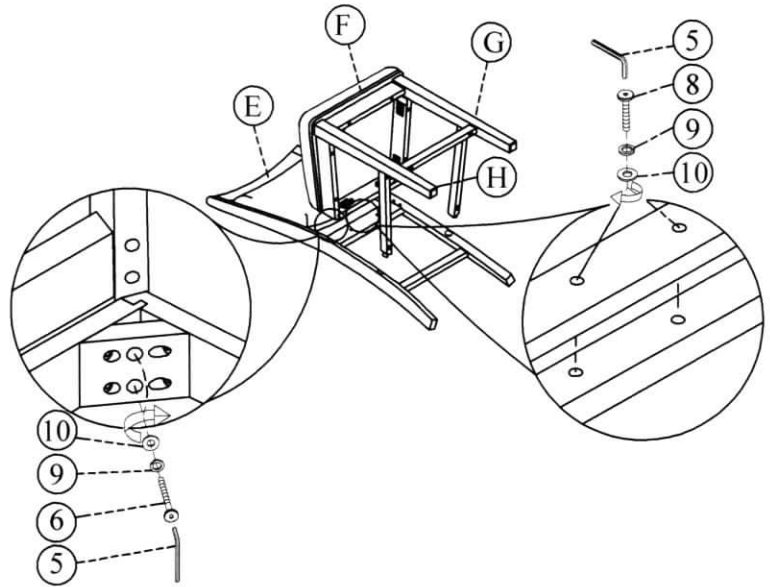

STEP 7

