

ASSEMBLY INSTRUCTIONS

ASSEMBLY TIPS:

- 1.Remove hardware from box and sort by size.
- 2.Please check to see that all hardware and parts are present prior to start of assembly.
- 3.Please follow attached instructions in the same sequence as numbered to assure fast & easy assembly.









WARNING !

- 1.Don't attempt to repair or modify parts that are broken or defective. Please contact the store immediately.
- 2.This product is for home uses only and not intended for commercial establishments.





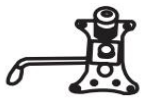
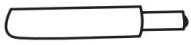

ASSEMBLY TIME 20 MINUTES

PARTS IDENTIFICATION

A		BACK	1PC
B		SEAT	1PC
C		LEFT ARM	1PC
D		RIGHT ARM	1PC
E		MECHANISM	1PC
F		GAS LIFT	1PC
G		BASE	1PC
H		CASTER	5PCS

HARDWARE IDENTIFICATION

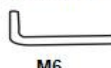
1	SHORT SCREW	 M6*20mm	8PCS
2	LONG SCREW	 M6*25mm	6PCS
3	SMALL FLAT WASHER	 M6*14mm	6PCS
4	LARGE FLAT WASHER	 M6*18mm	8PCS
5	ALLEN KEY	 M6	1PC

STEP1

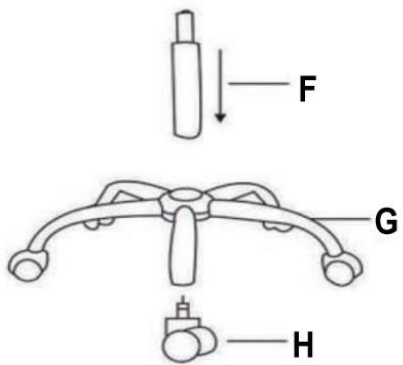

STEP2

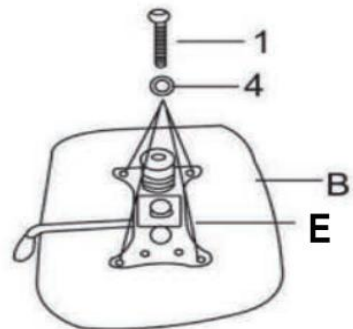

STEP3

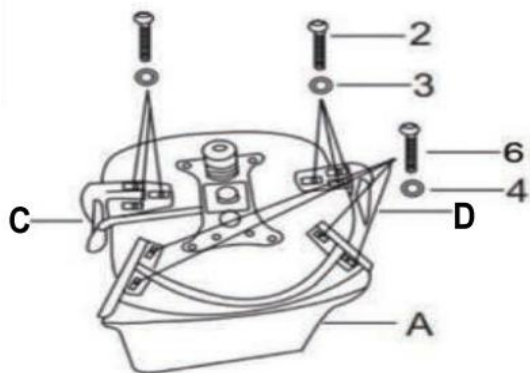

STEP4

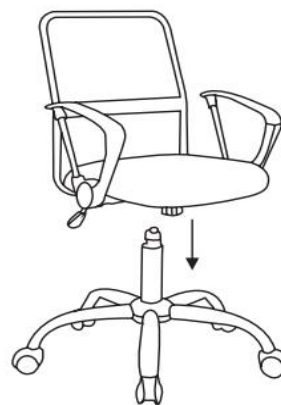

STEP5

