

Assembly Instructions

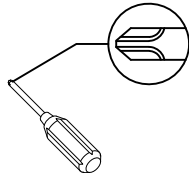

General Assembly Guidelines

- I. Ensure that all parts and hardware are available before beginning assembly.
- II. Follow each step carefully to ensure the proper assembly of this product.
- III. Two people are recommended for ease in the assembly of this product.
- VI. A Phillips head screwdriver is required for the assembly of this product .



- V. The provided glue is to secure wood dowels in place . When first inserting dowels , locate the appropriate hole for the dowel , place a small amount of glue in the hole and insert the dowel . Wipe away excess glue immediately.

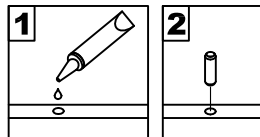

In future assembly steps when dowels are necessary to attach assembly parts together , place a small amount of glue on the end of the dowel before attaching parts together . Wipe away excess glue immediately.

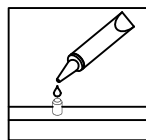

- VI. **HOW THE KNOCK DOWN (KD) ASSEMBLY SYSTEM WORKS**
 - 1.Screw the Cam Bolt into the pre-drilled hole on the panel. Make sure Cam Bolt goes into the pre-drilled hole on the end of panel for Cam Lock.
 - 2.Insert the Cam Lock into the pre-drilled large hole on the panel. Make sure the arrow on the face of Cam Lock points towards Cam Bolt.
 - 3.Take a Phillips screwdriver and rotate the Cam Lock clockwise to lock the Cam Bolt.
 - 4.Use the sticker to conceal the Cam.

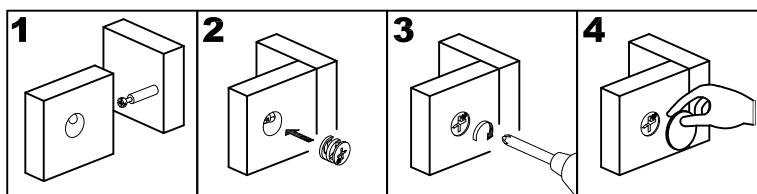



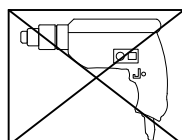



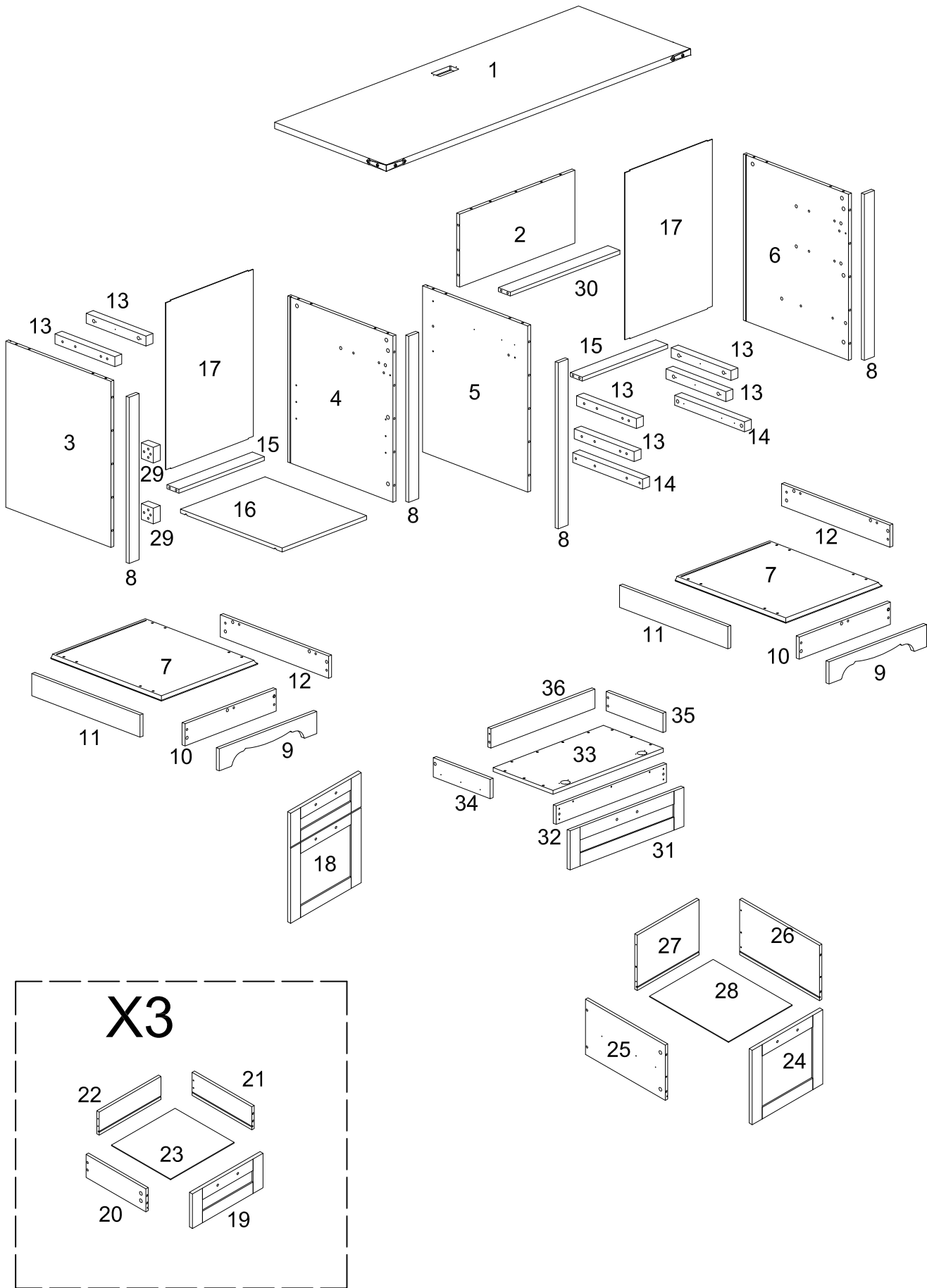



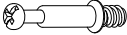

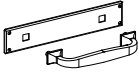

- VII. Power tools should not be used to assemble this product .

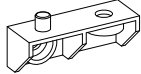

Parts List







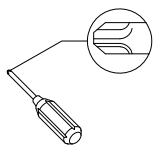







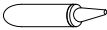

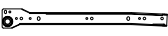

Hardware List

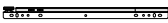
A		Ø8x30mm	Dowel	60 pcs
B		Ø6x35mm	Cam Bolt	49 pcs
C		Ø15x12mm	Cam Lock	33 pcs
D		Ø15x10mm	Cam Lock (Small)	16 pcs
E		Ø30mm	Cover	49 pcs
F			Handle	7 pcs
G		Ø4x12mm	Handle bolt	14 pcs
H			Connector	20 pcs
I		1/4"x12mm	Bolt	40 pcs
J		Ø8x5x16mm	Shelf support pin	4 pcs
K		Ø6x50mm	Screw	16 pcs
L		Ø3x12mm	Screw	38 pcs
M		Ø3x12mm	Screw	24 pcs
N		Ø4x32mm	Screw	16 pcs
O		Ø35	Europe Hinge	2 pcs
P		Ø3.5x14mm	Screw	20 pcs

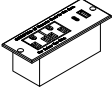
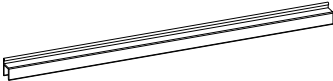

Philips head screwdriver required for assembly
(not included)

Hardware List

Q		Ø8x20mm	Dowel	2 pcs
R		Ø6x30mm	Dowel	4 pcs
S			Glue Tube	1 pc
T			Plastic Wedge	20 pcs
U		Ø3x17mm	Flat-head Screw	20 pcs
V		M4	Allen Wrench	1 pc
W		14"	Drawer Slider	1 set
X		12"	Left cabinet member	3 pcs
Y		12"	Right cabinet member	3 pcs
Z		12"	Left drawer runner	3 pcs
AA		12"	Right drawer runner	3 pcs
BB			Power Cord W/USB	1 pc
CC			File rail	2 pcs
DD		Ø4x25mm	Screw	7 pcs
EE		1/4x40mm	Bolt	20 pcs
FF			Flat washer	20 pcs
GG		12"	Drawer Slider	1 set
HH		Ø35	Europe Hinge	2 pcs

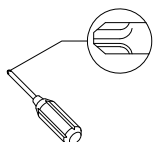

Philips head screwdriver required for assembly
(not included)

Step 1

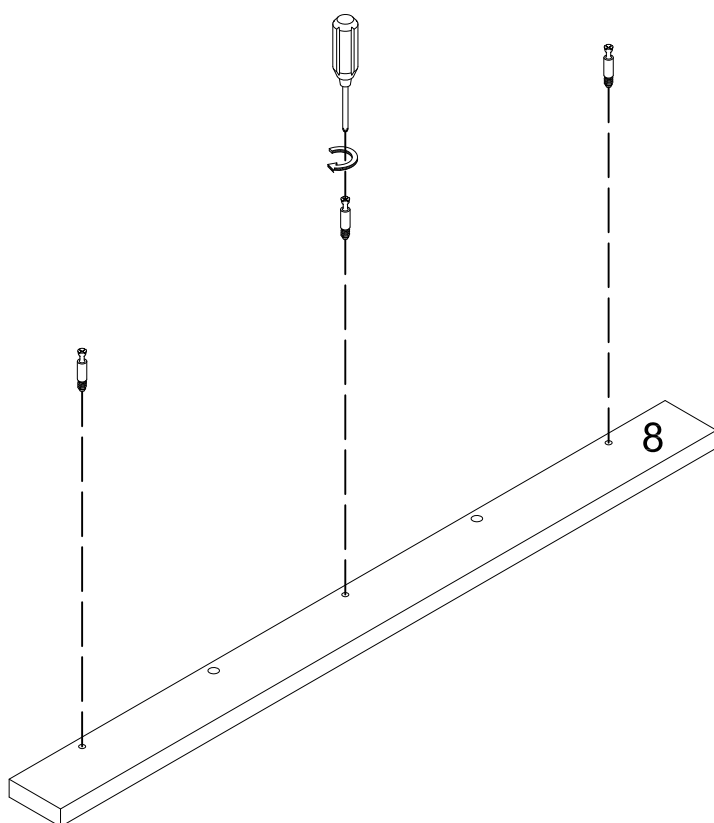
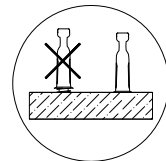

X4

Step 2

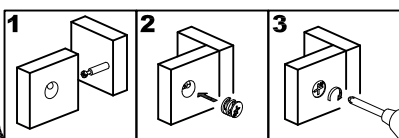
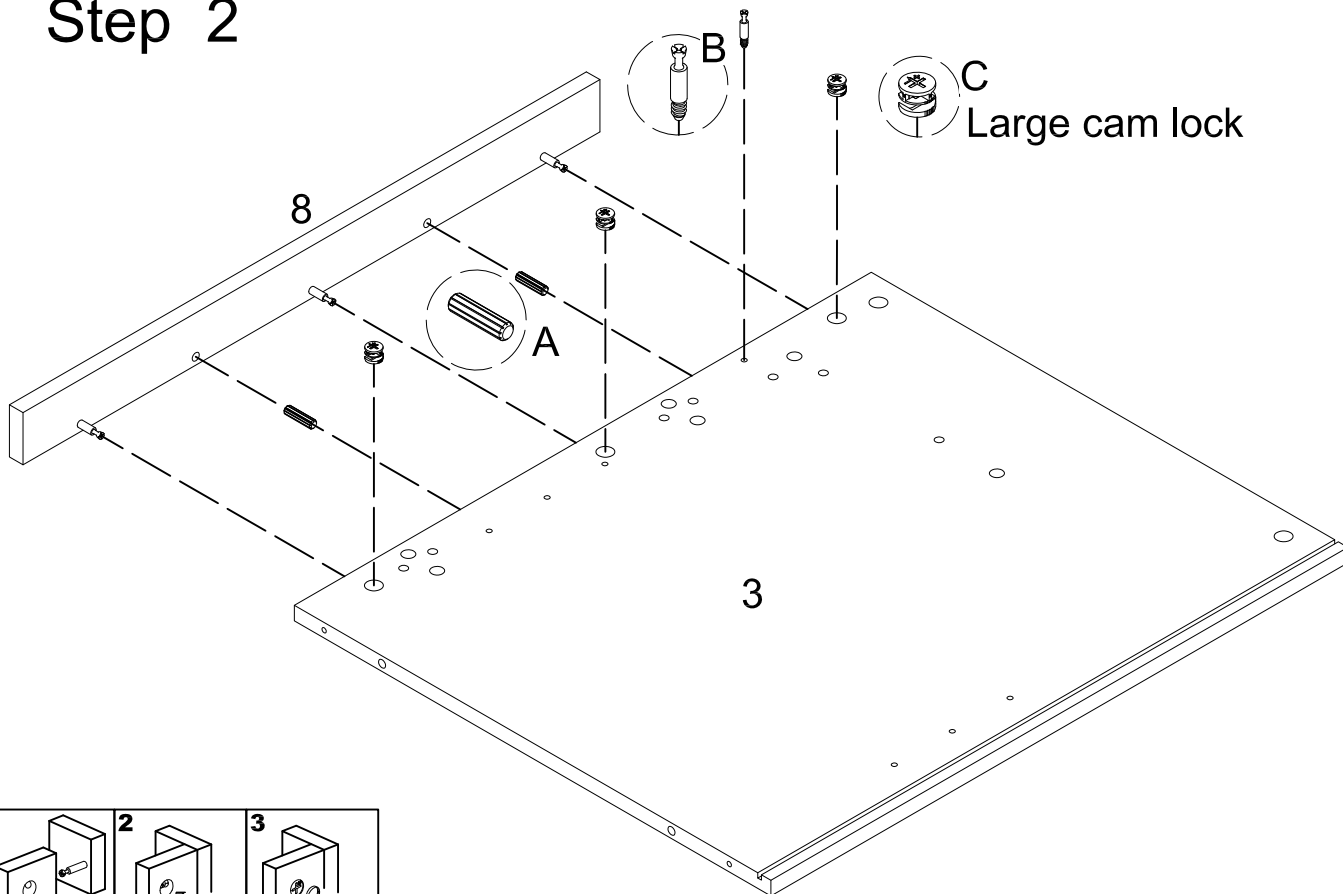

Step 3

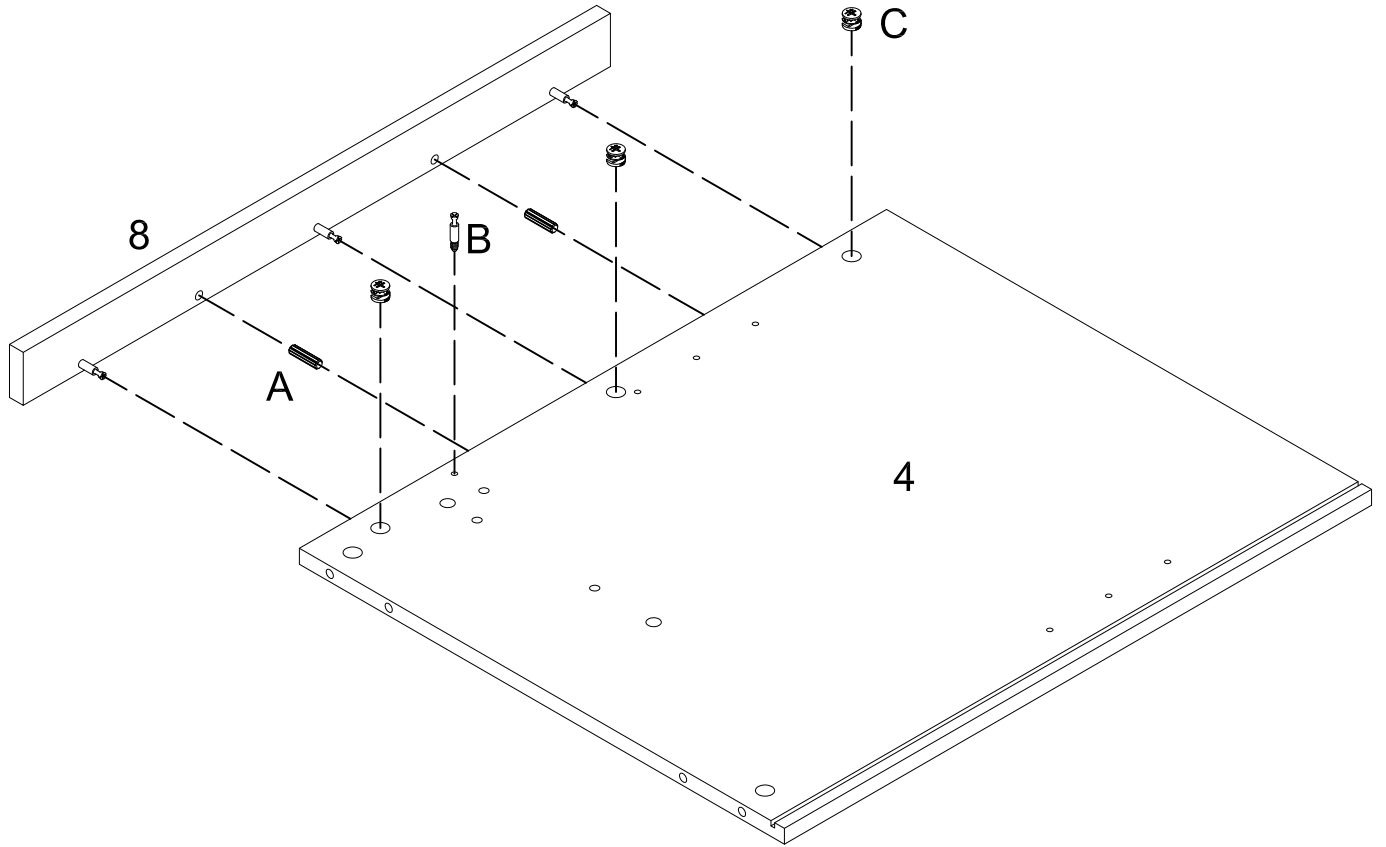

Step 4

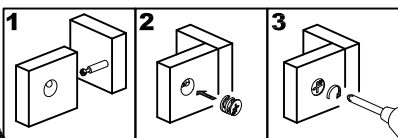
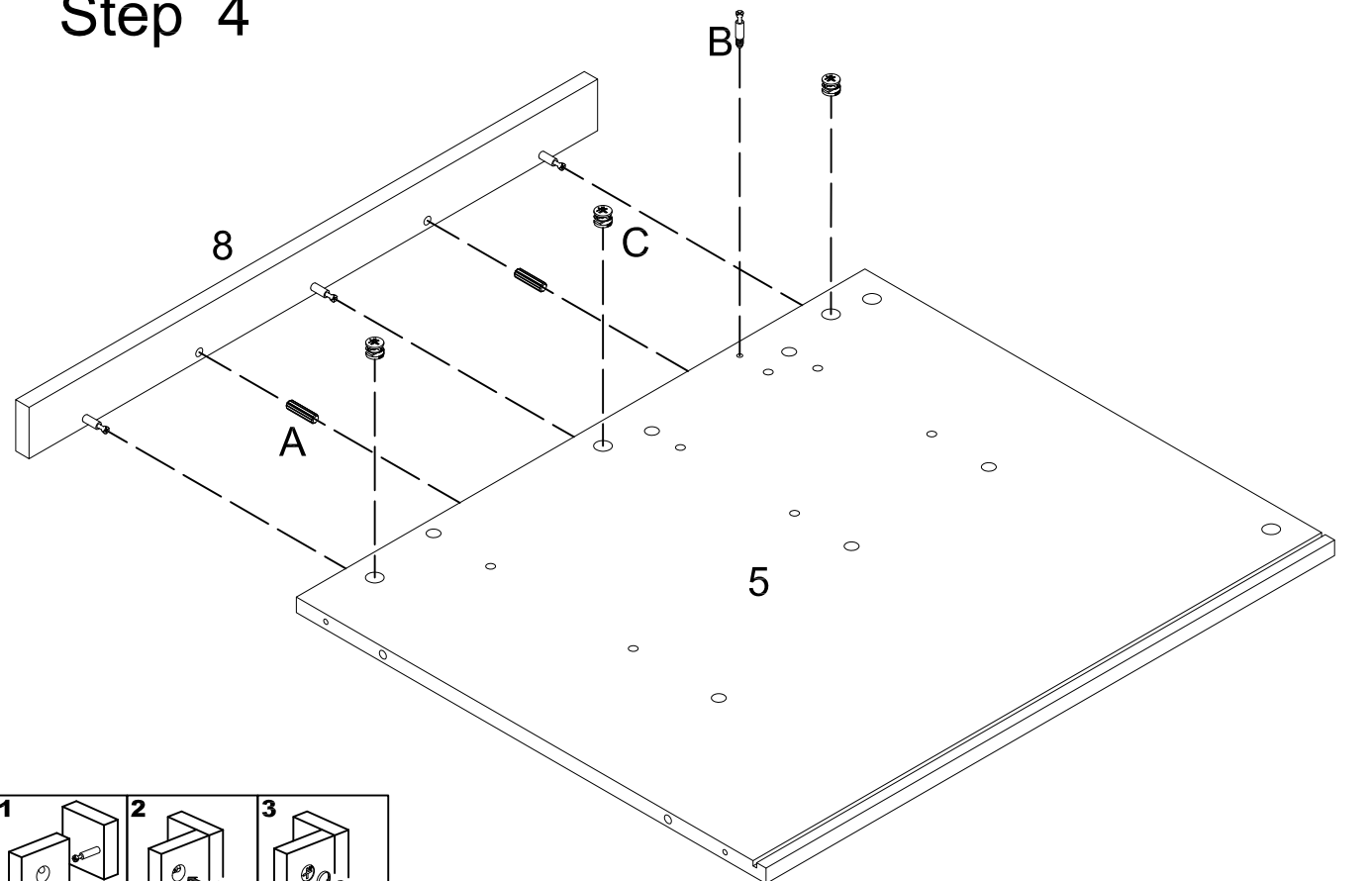

Step 5

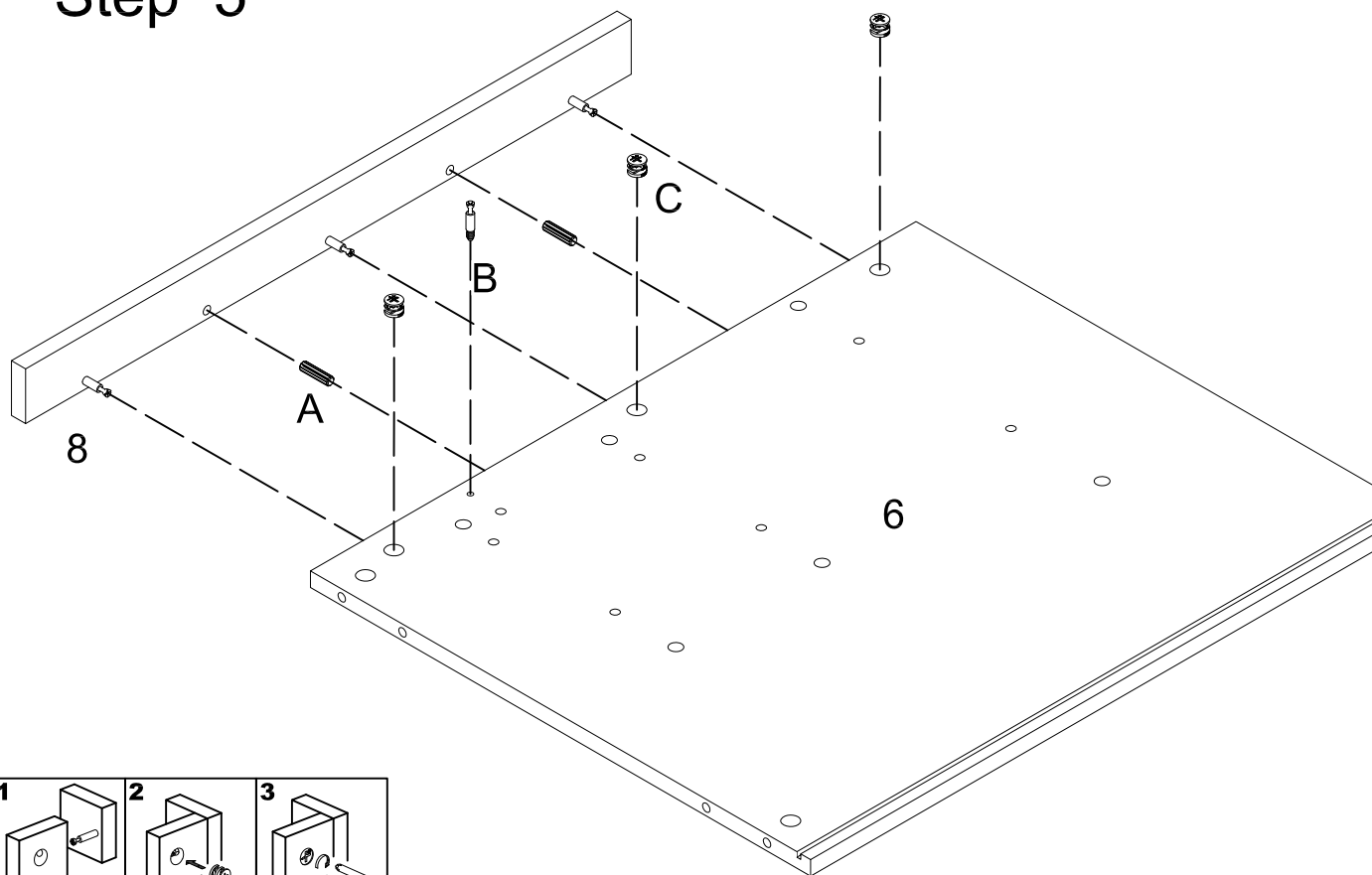

Step 6

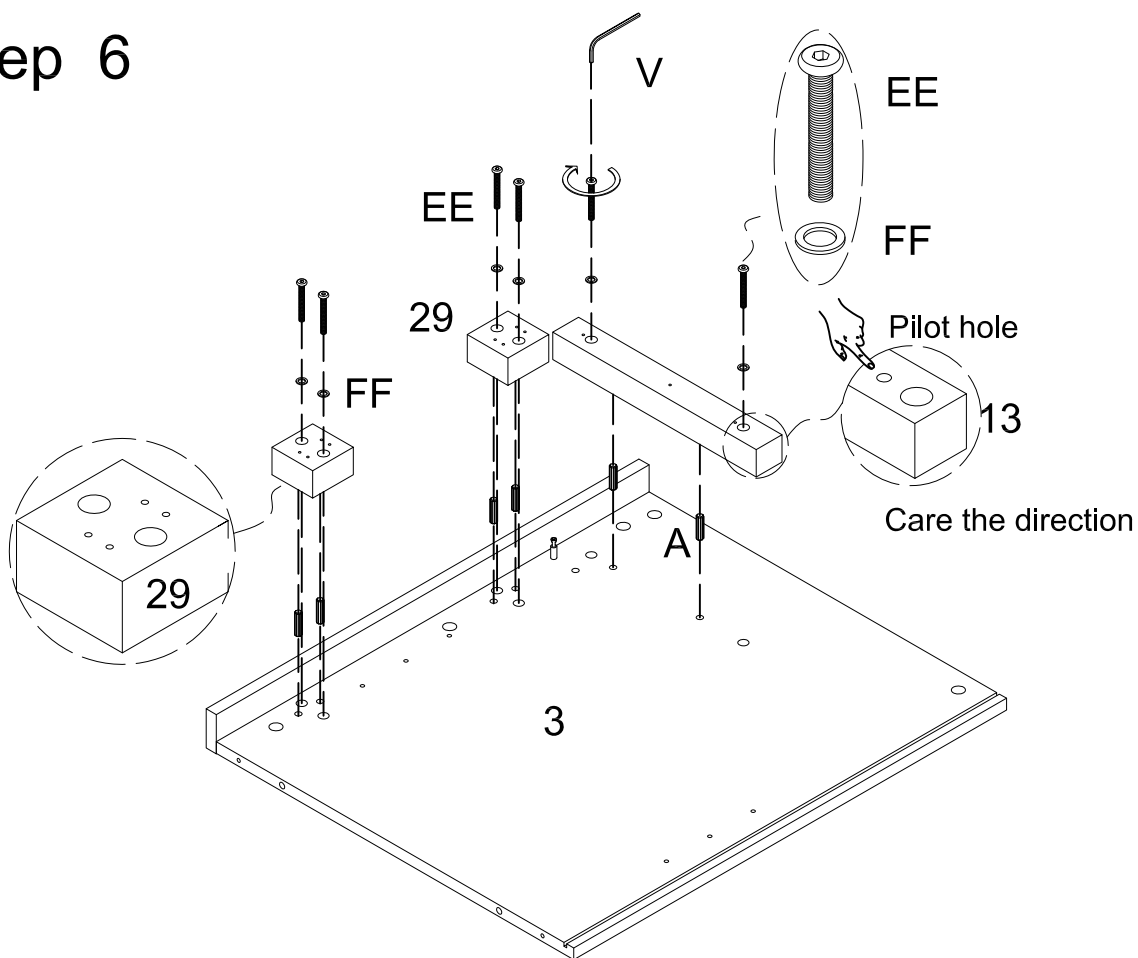

Step 7

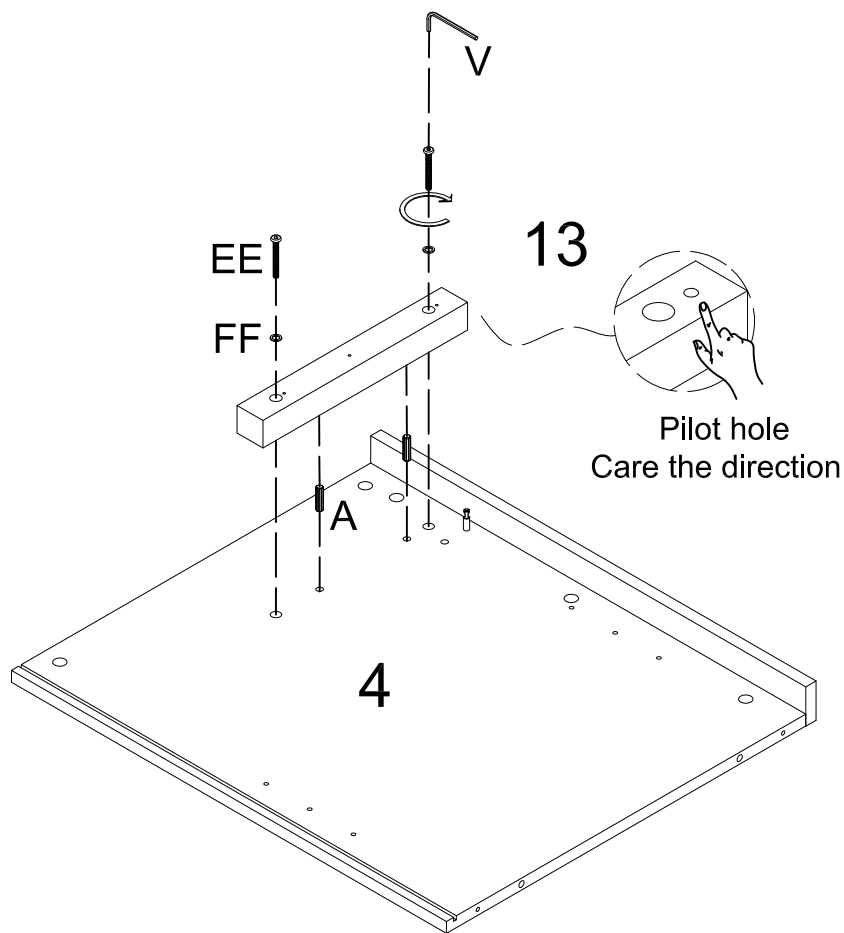

Step 8

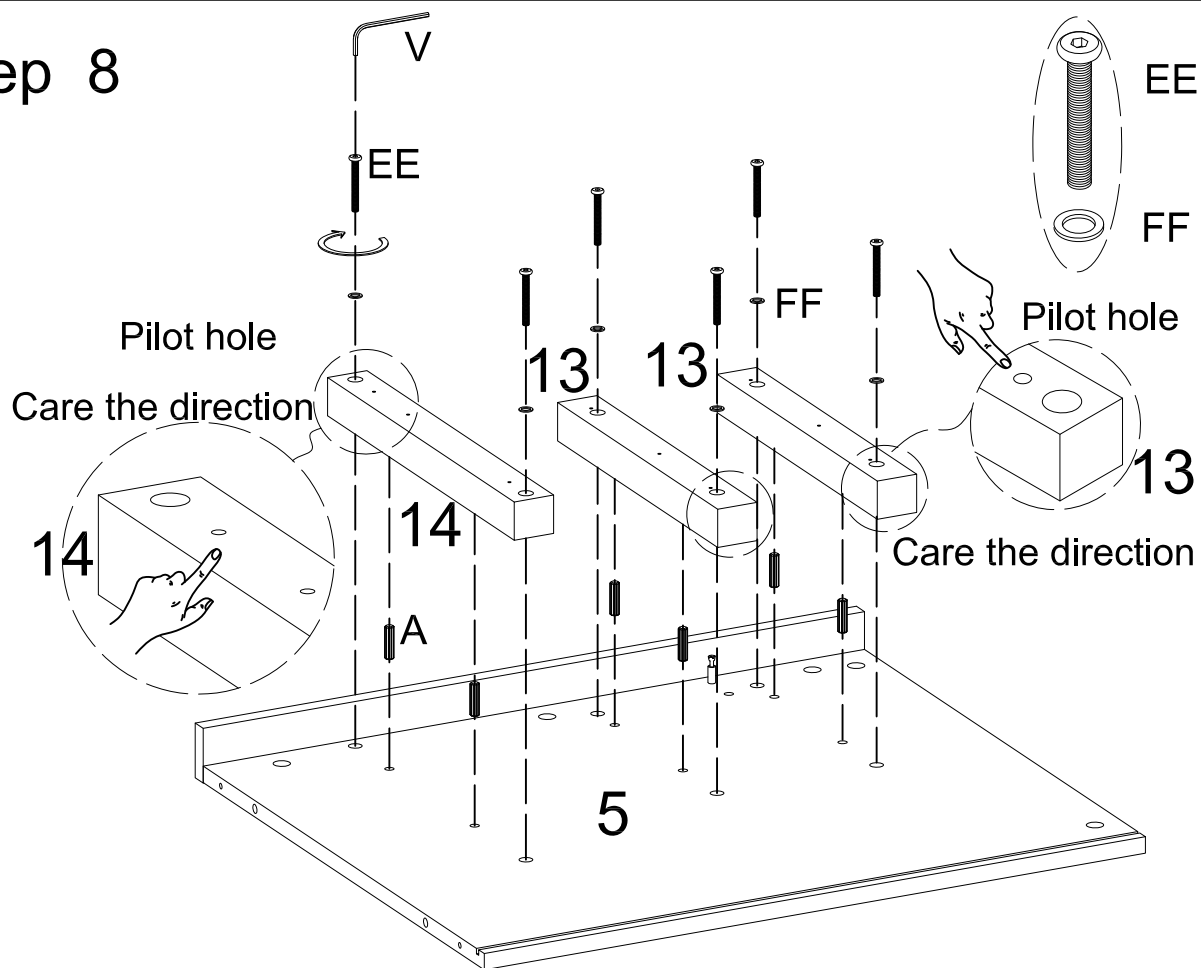

Step 9

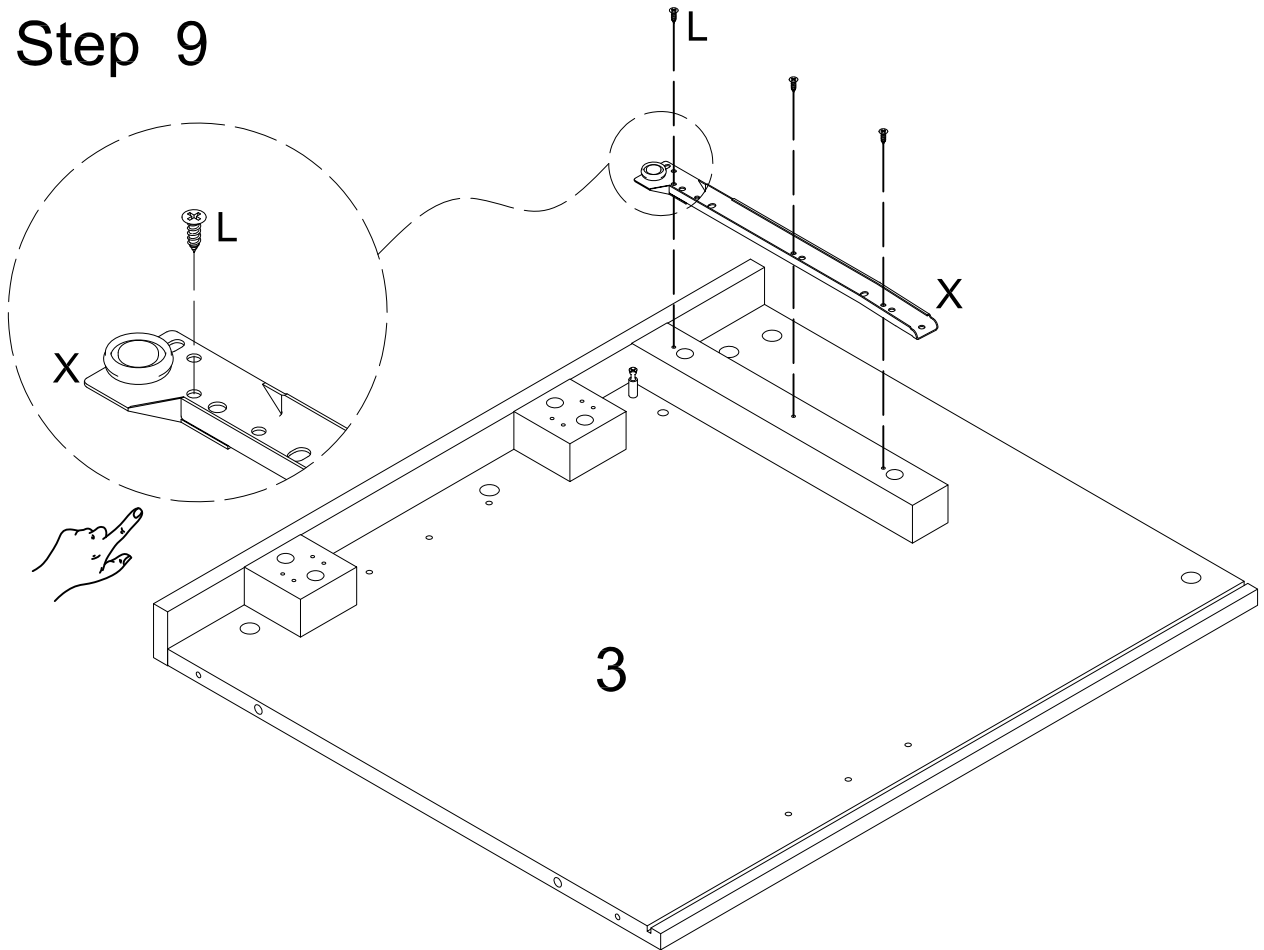

Step 10

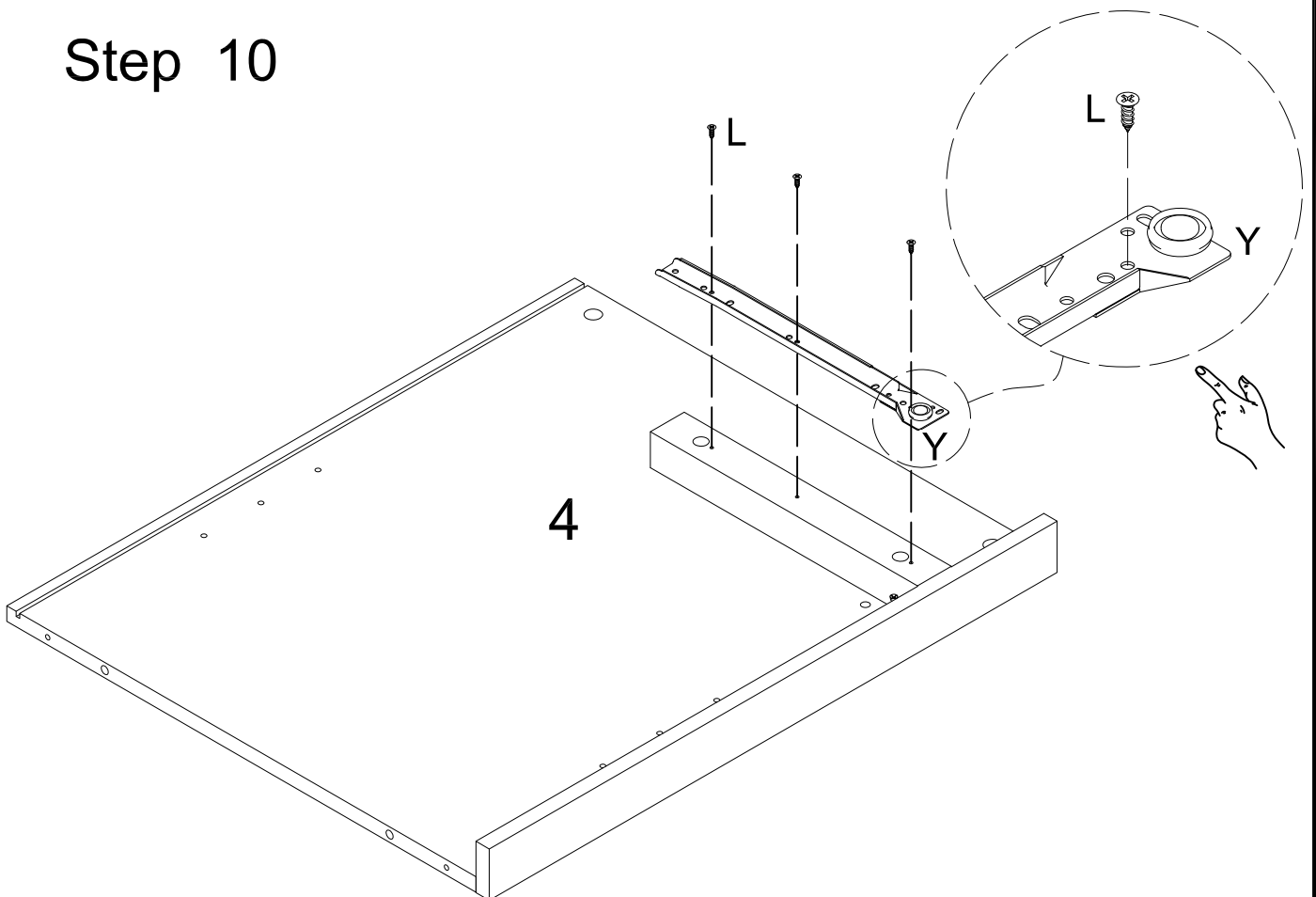

Step 11

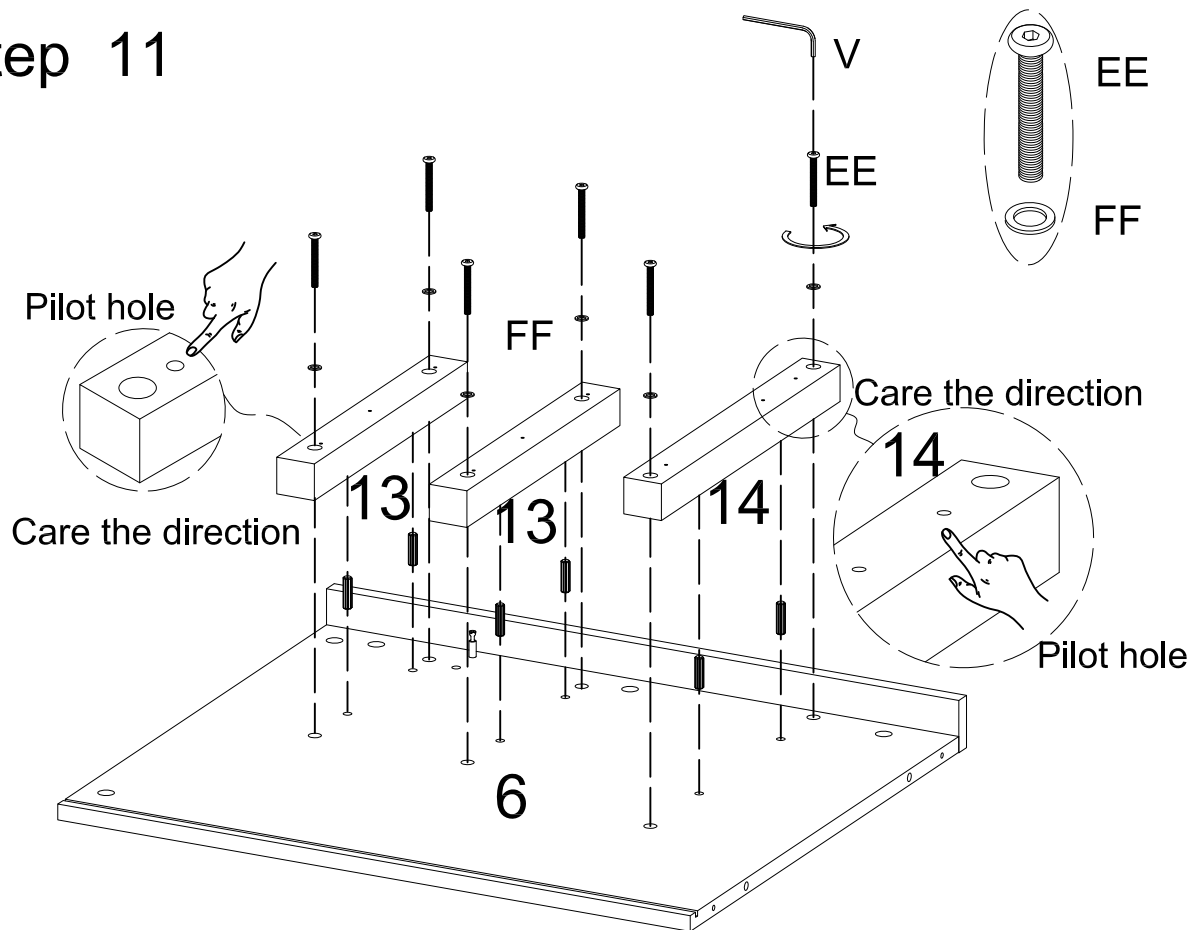

Step 12

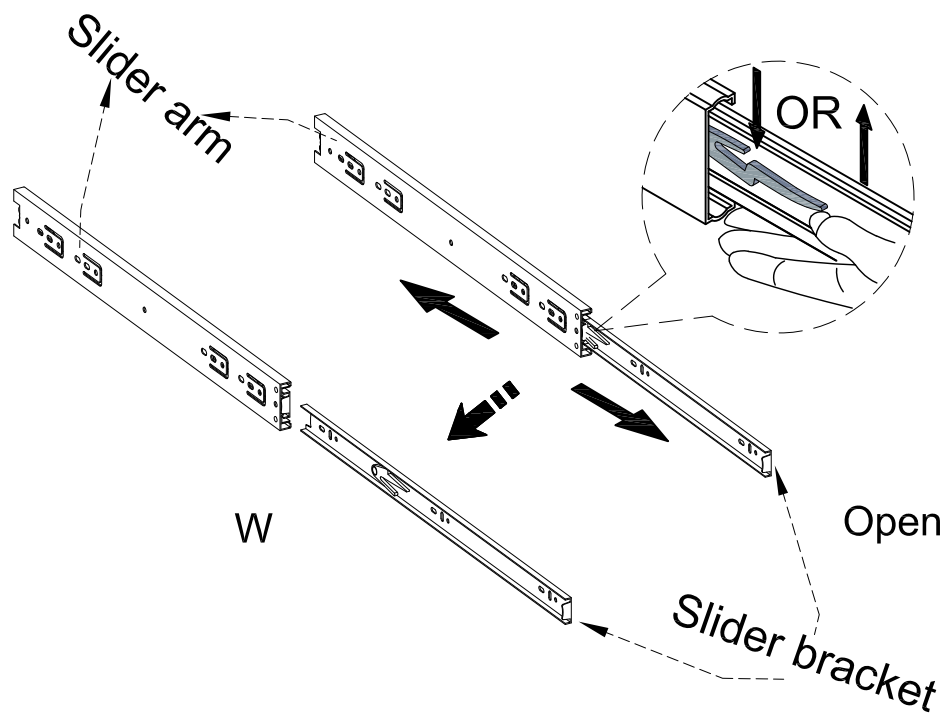

Step 13

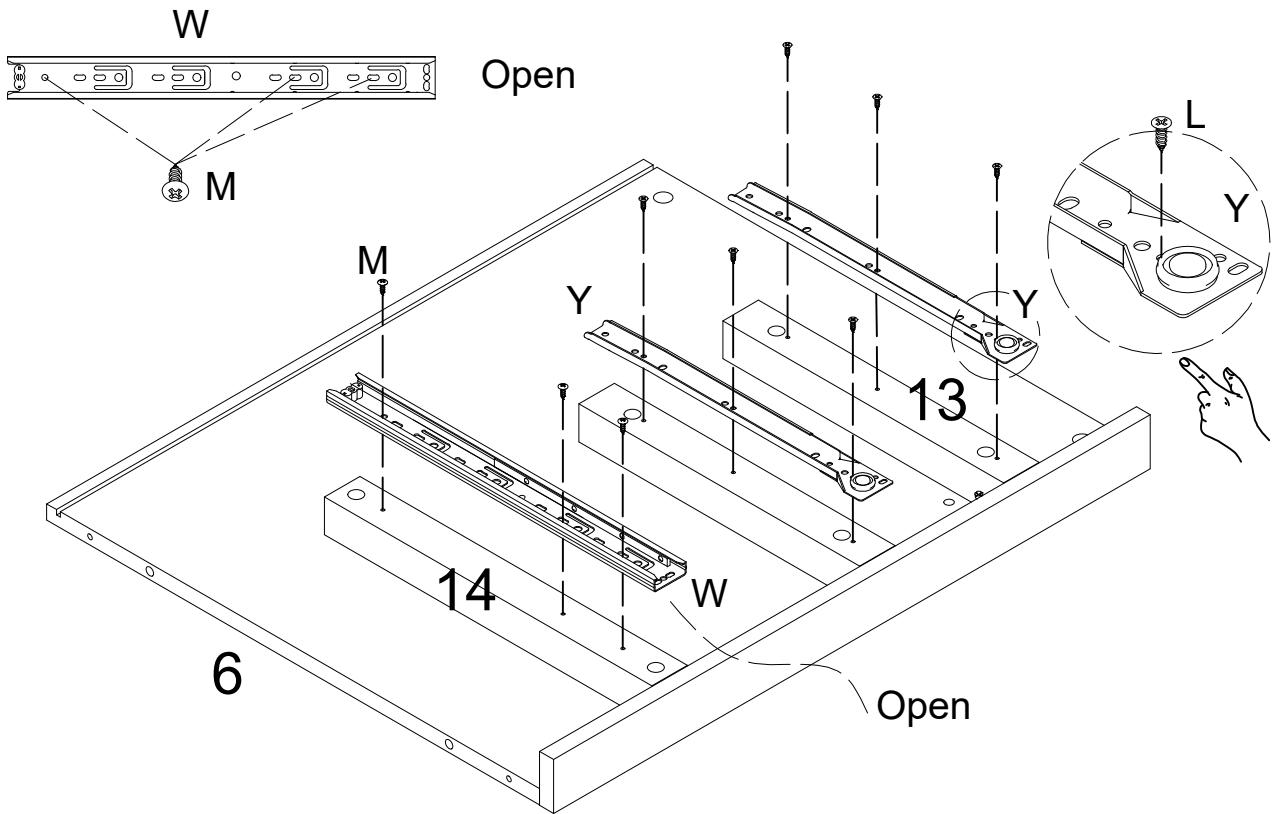

Step 14

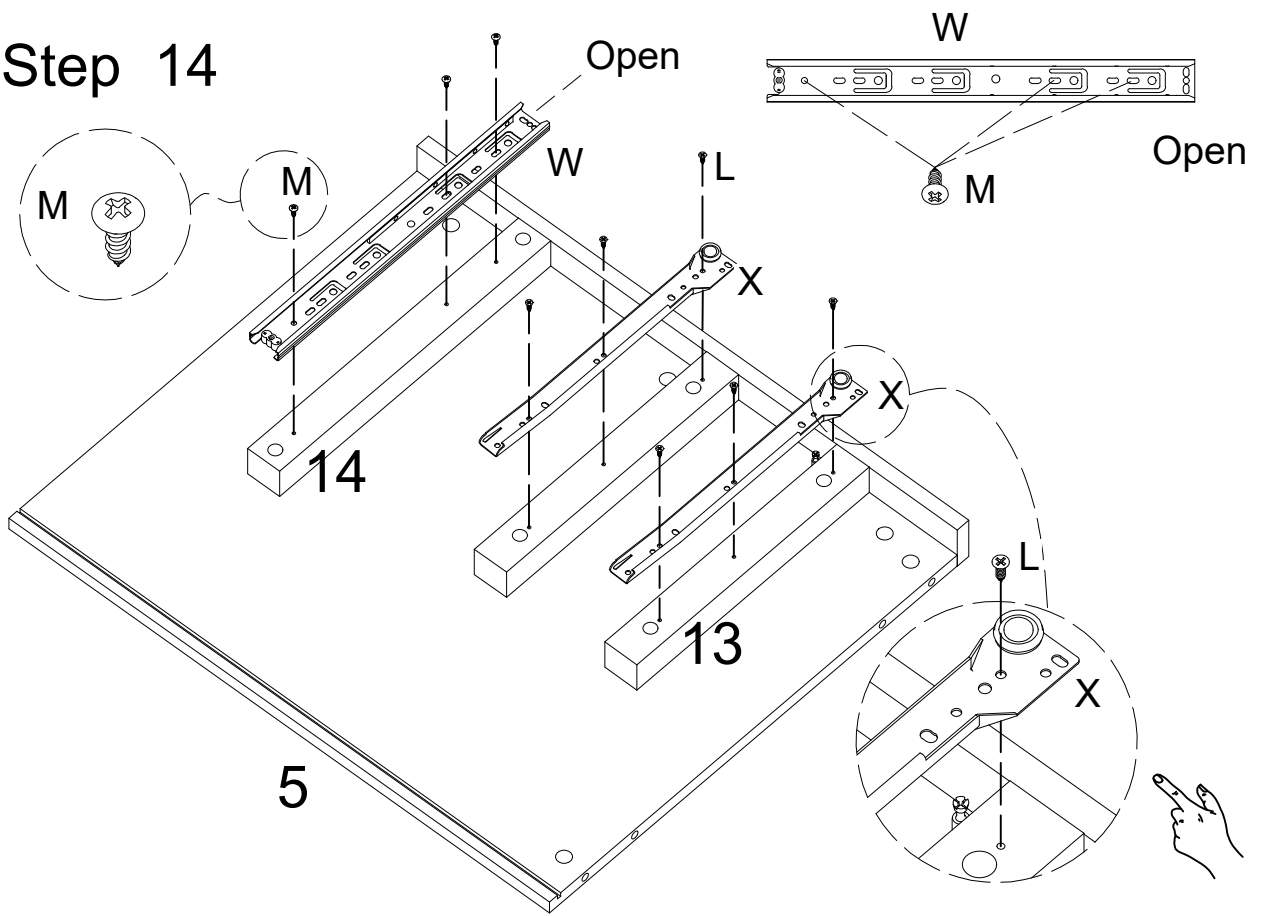

Step 15

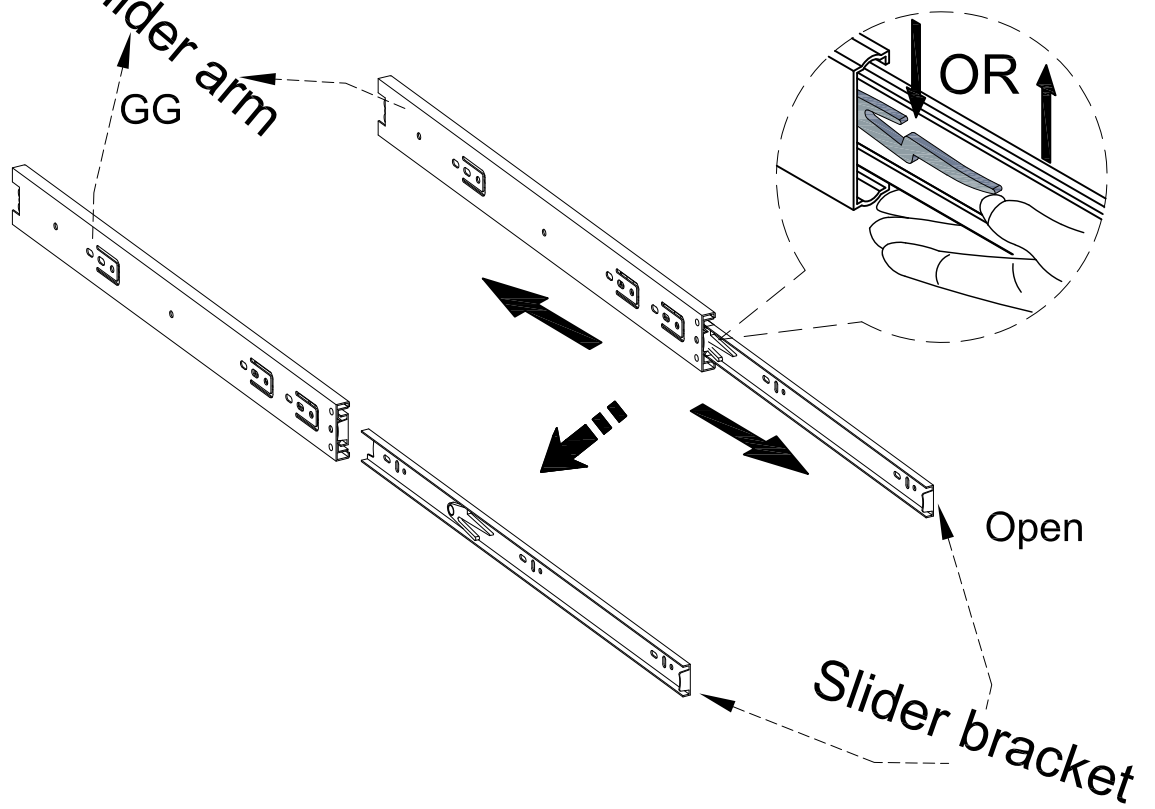

Step 16

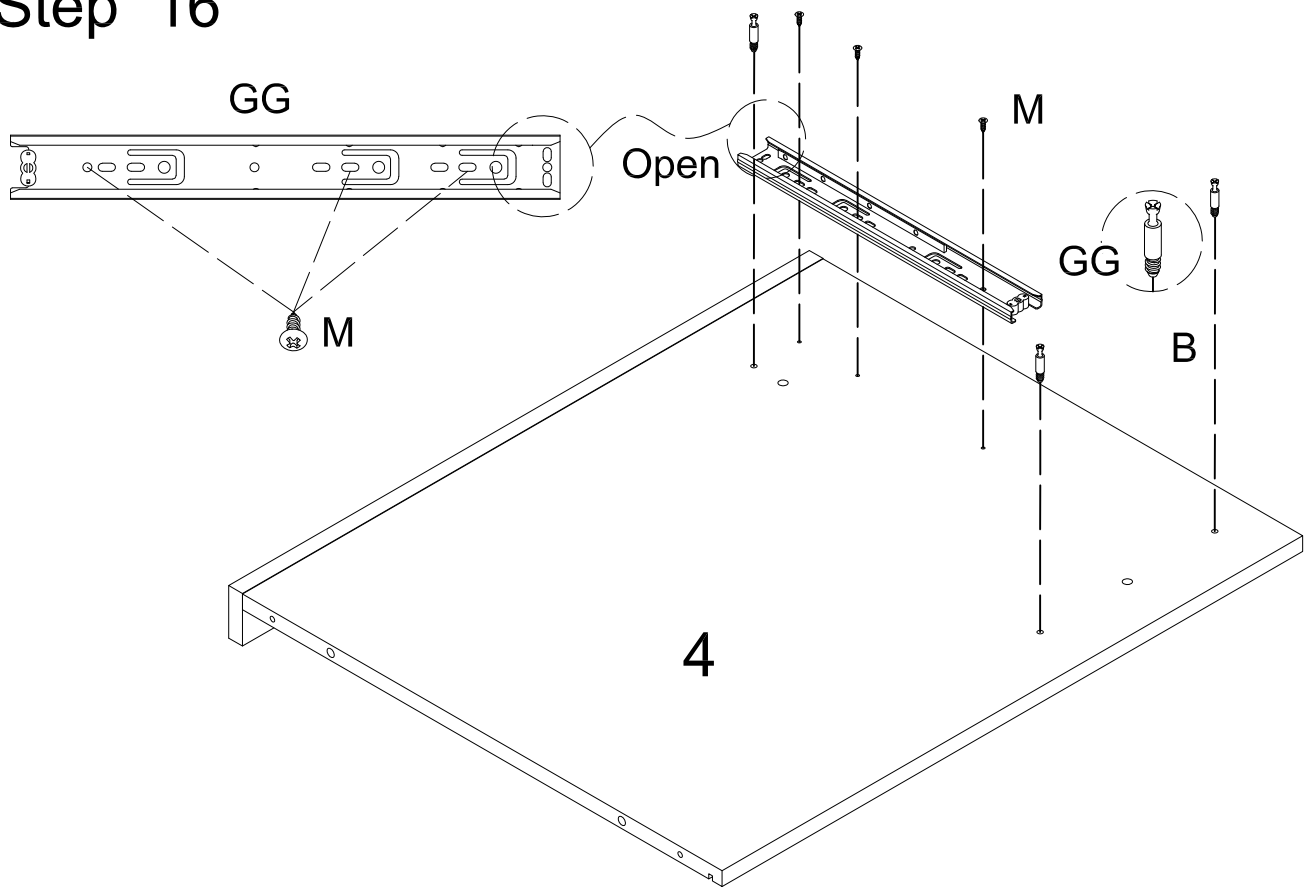

Step 17

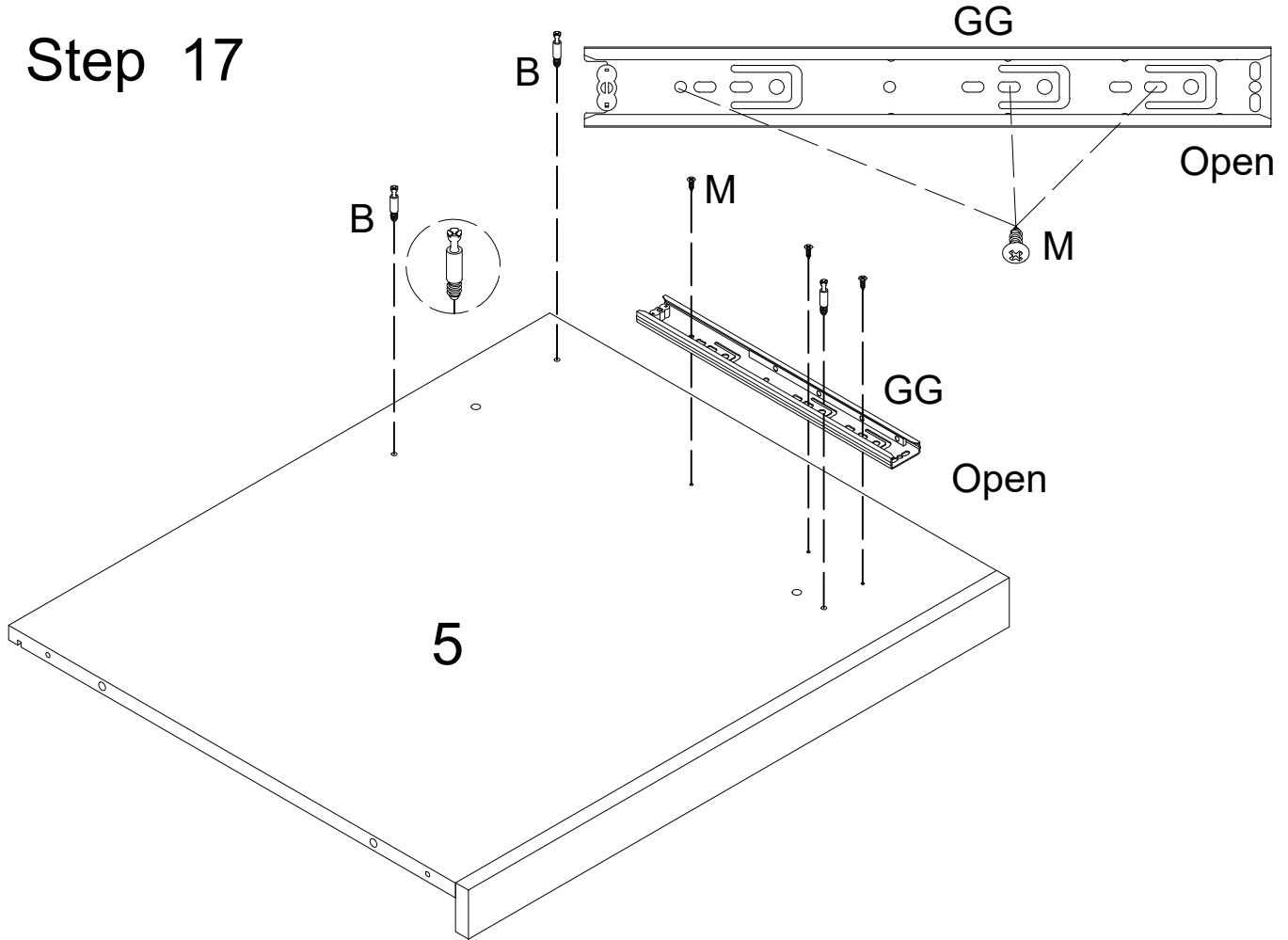

Step 18

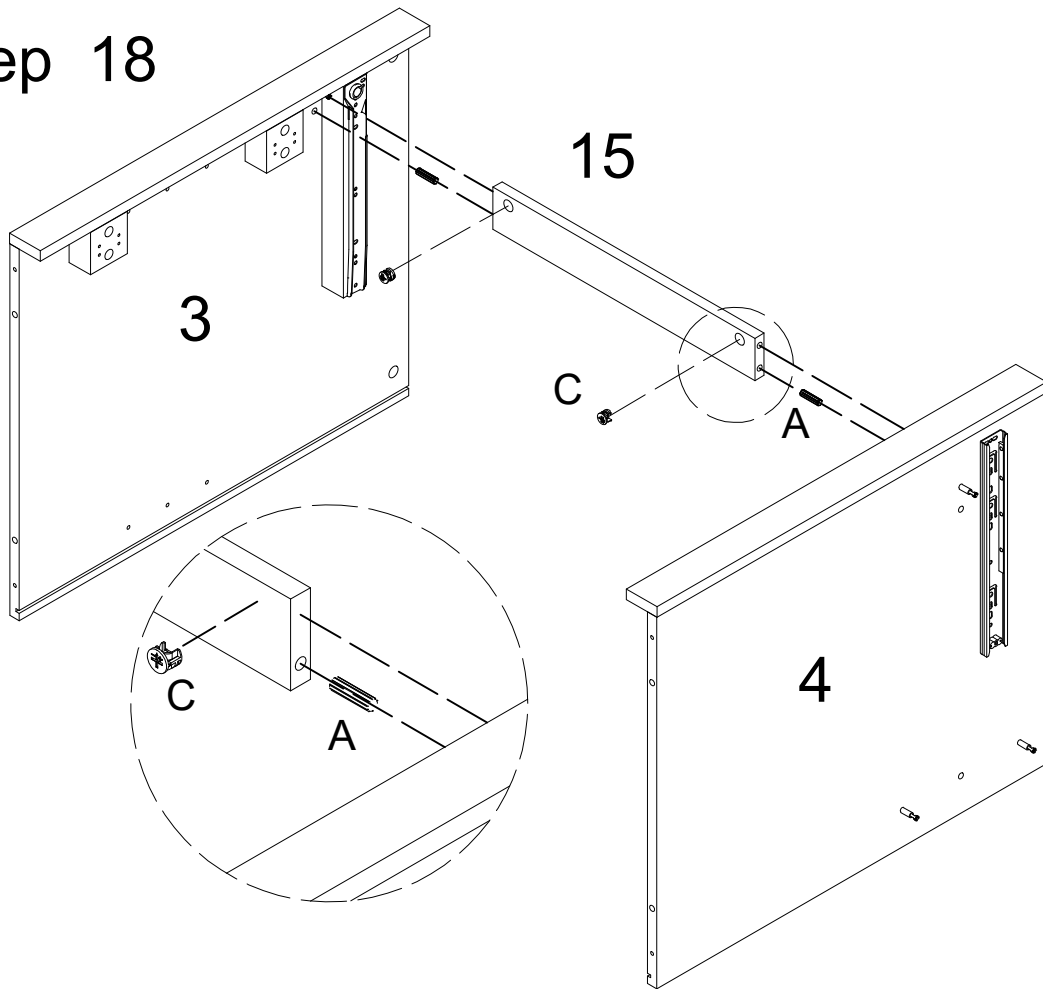

Step 19

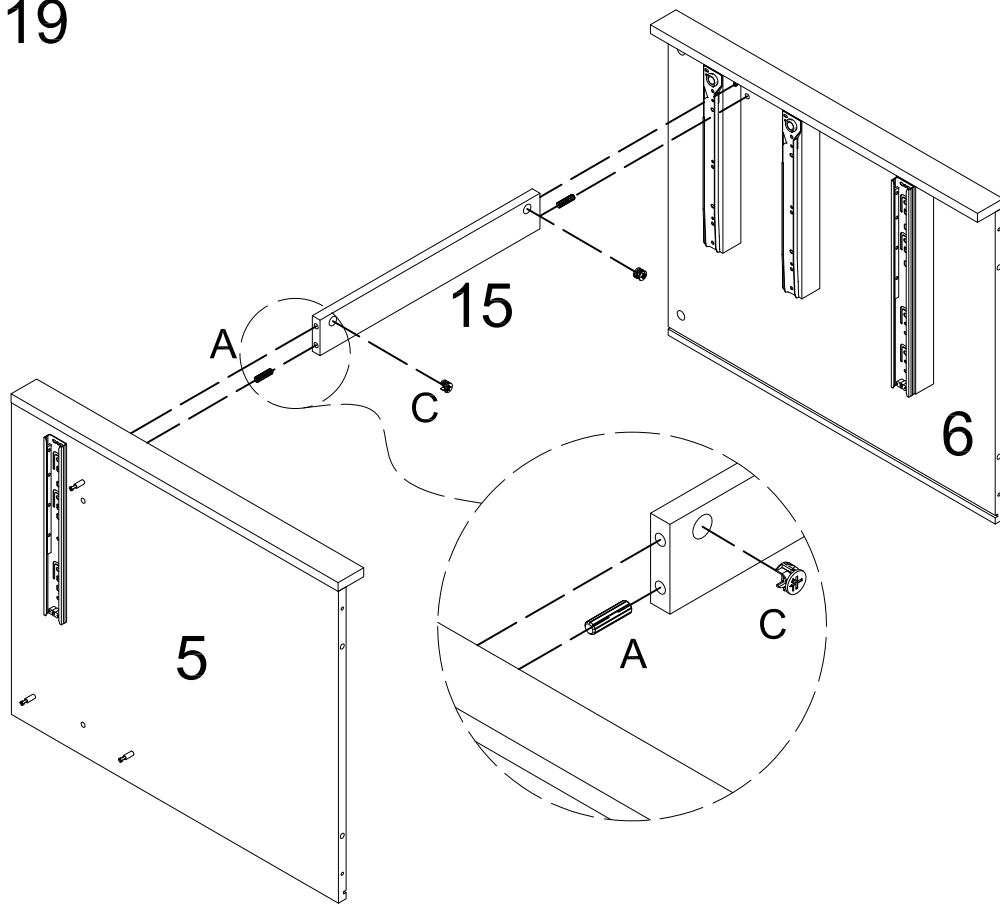

Step 20

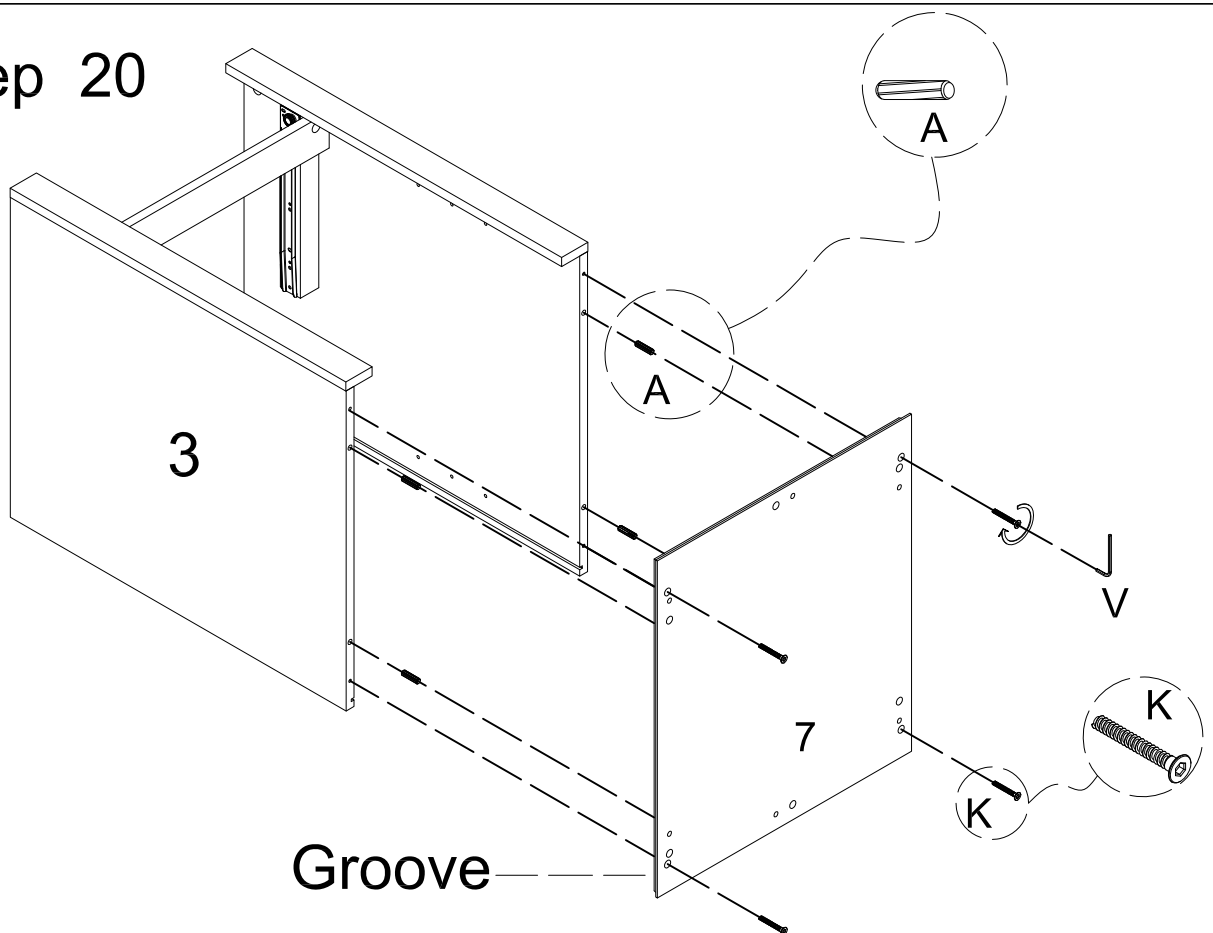

Step 21

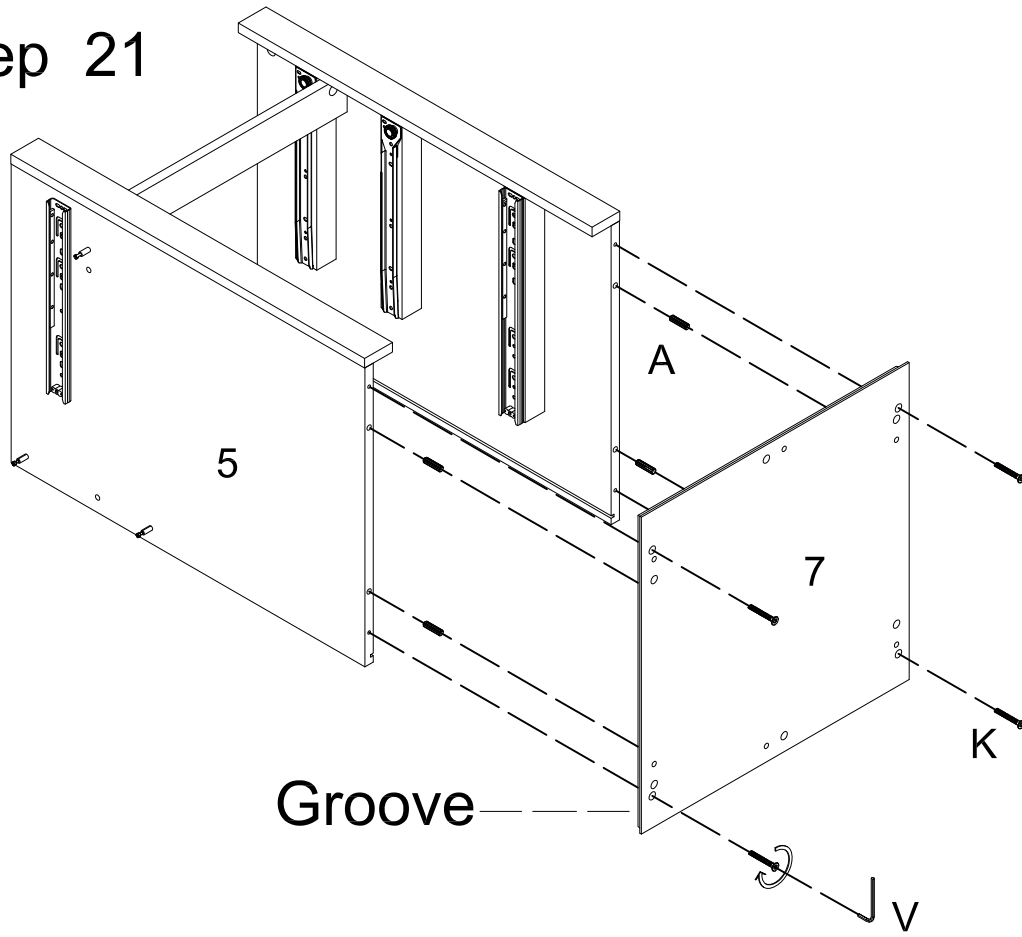

Step 22

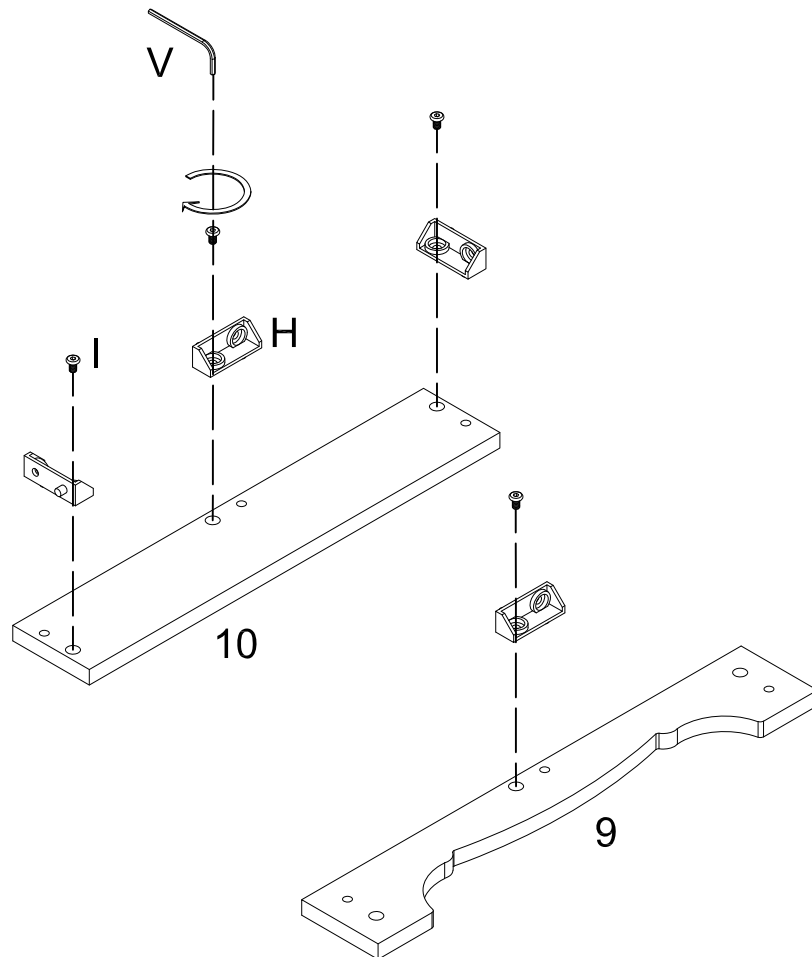

X2

Step 23

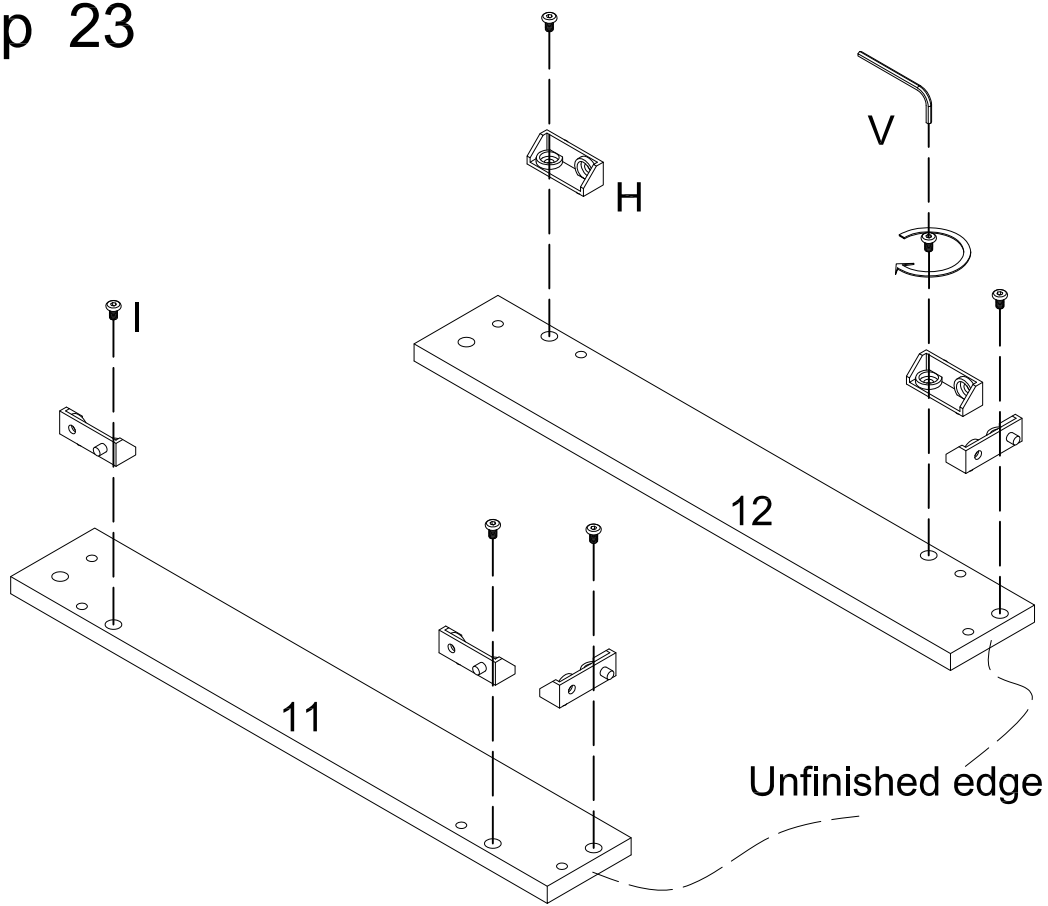

Step 24

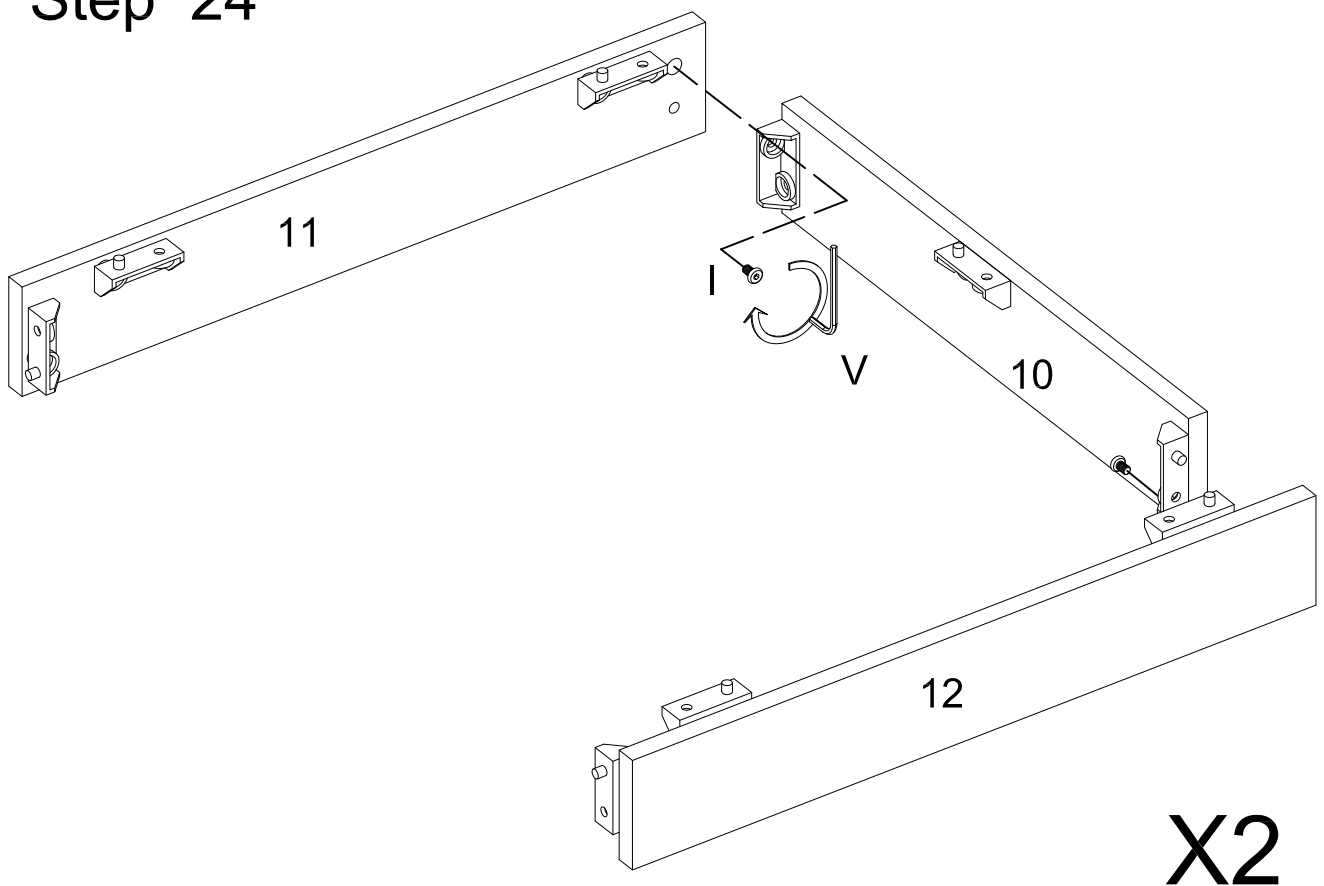

Step 25

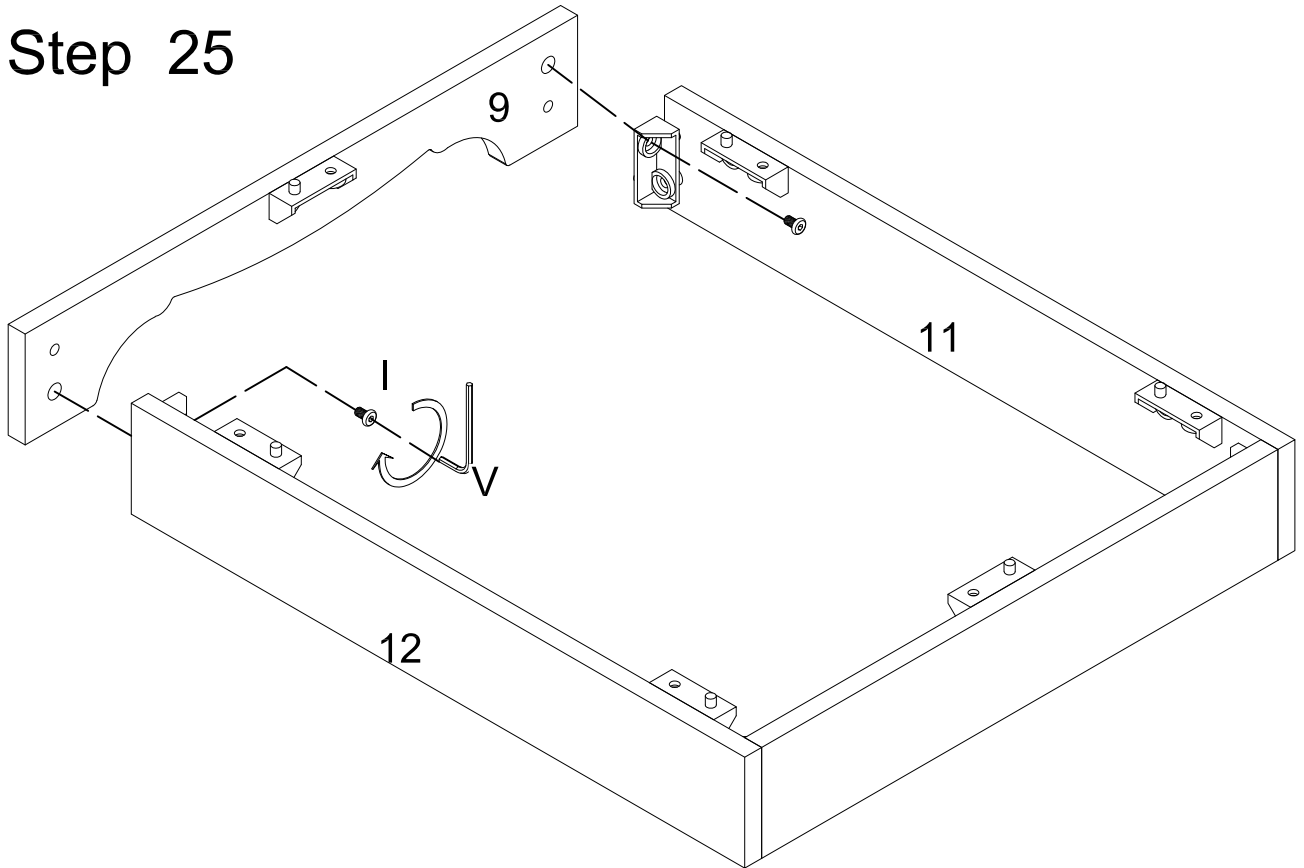

X2

Step 26

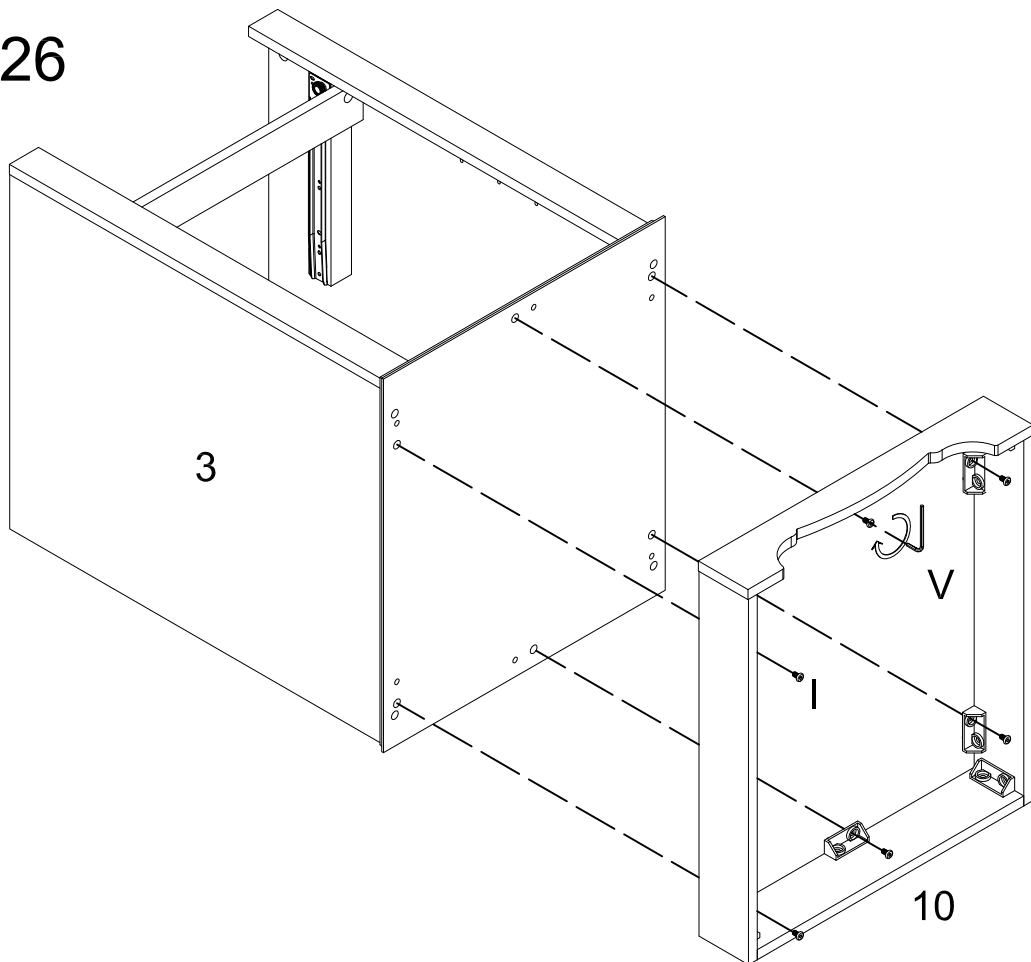

Step 27

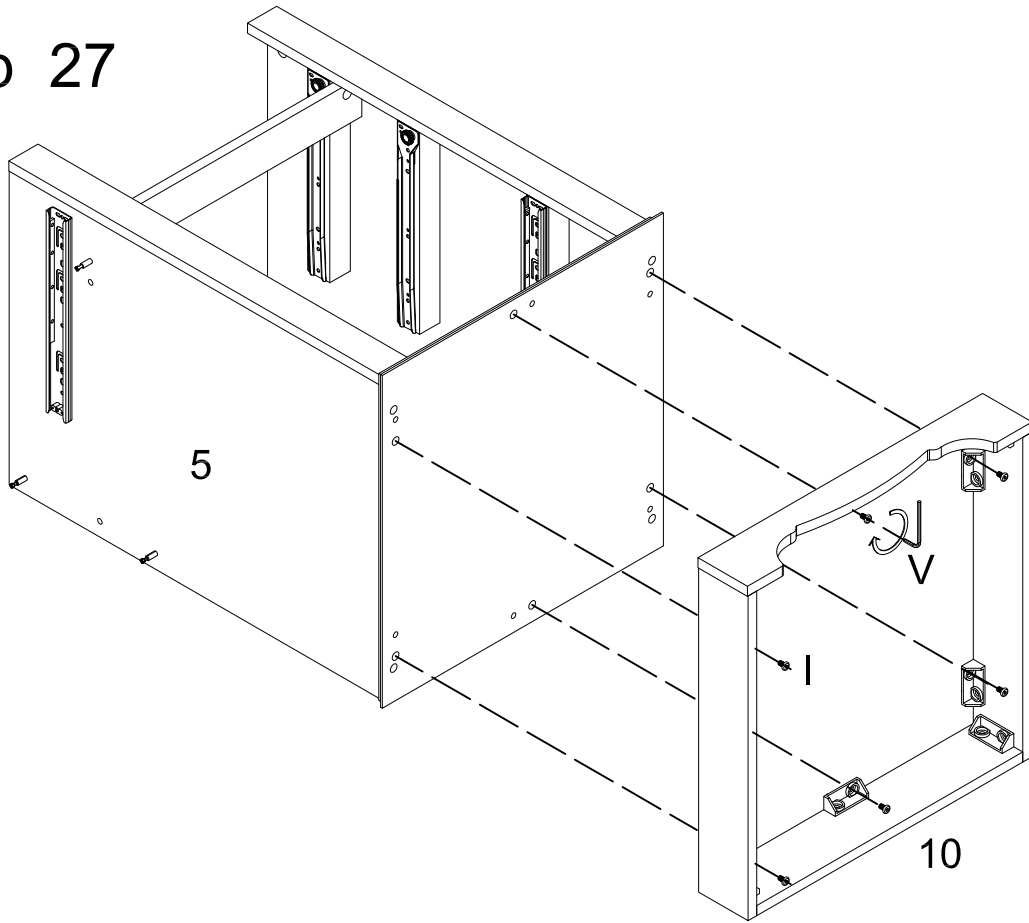

Step 28

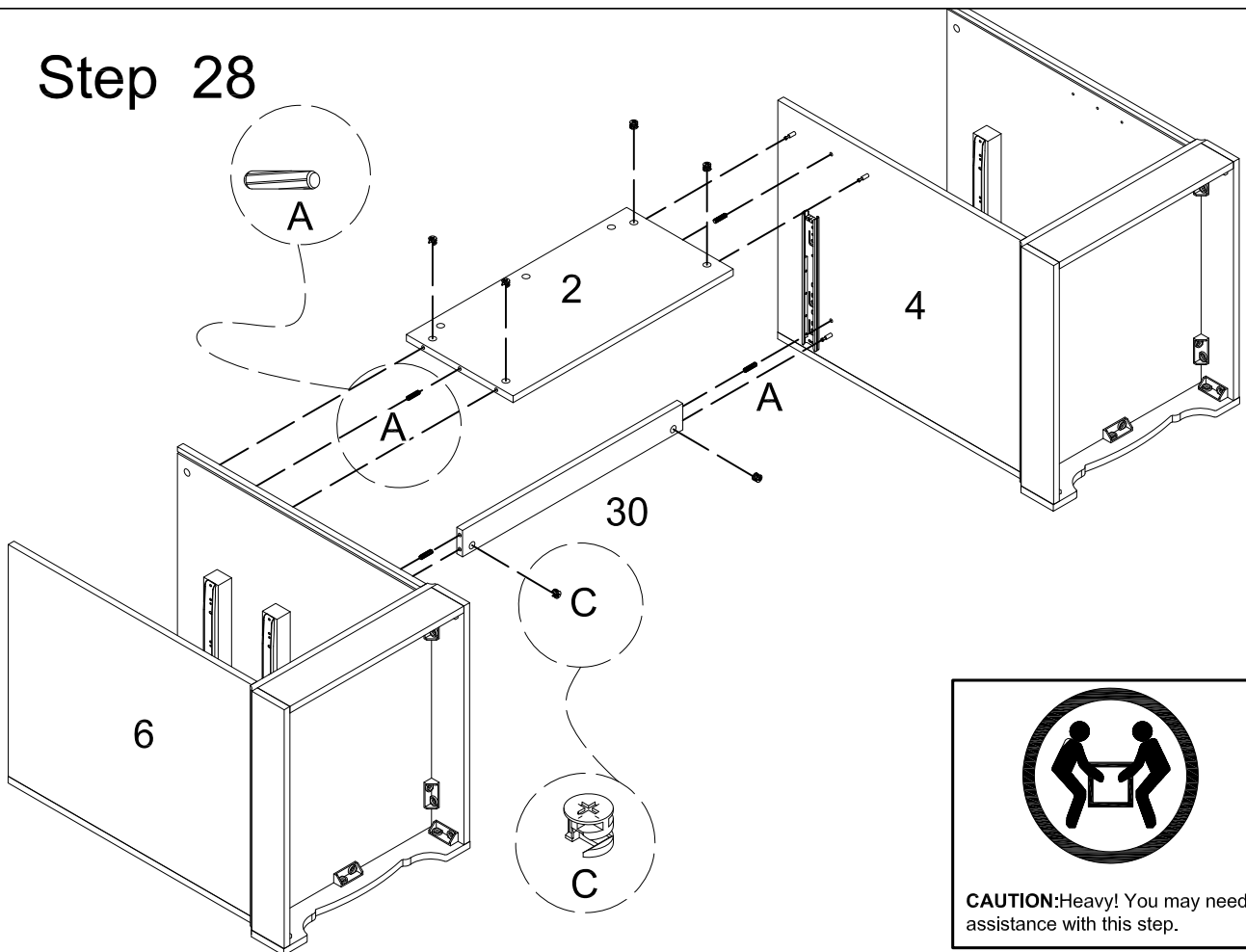

CAUTION: Heavy! You may need assistance with this step.

Step 29

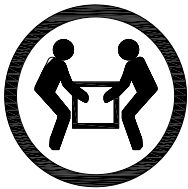
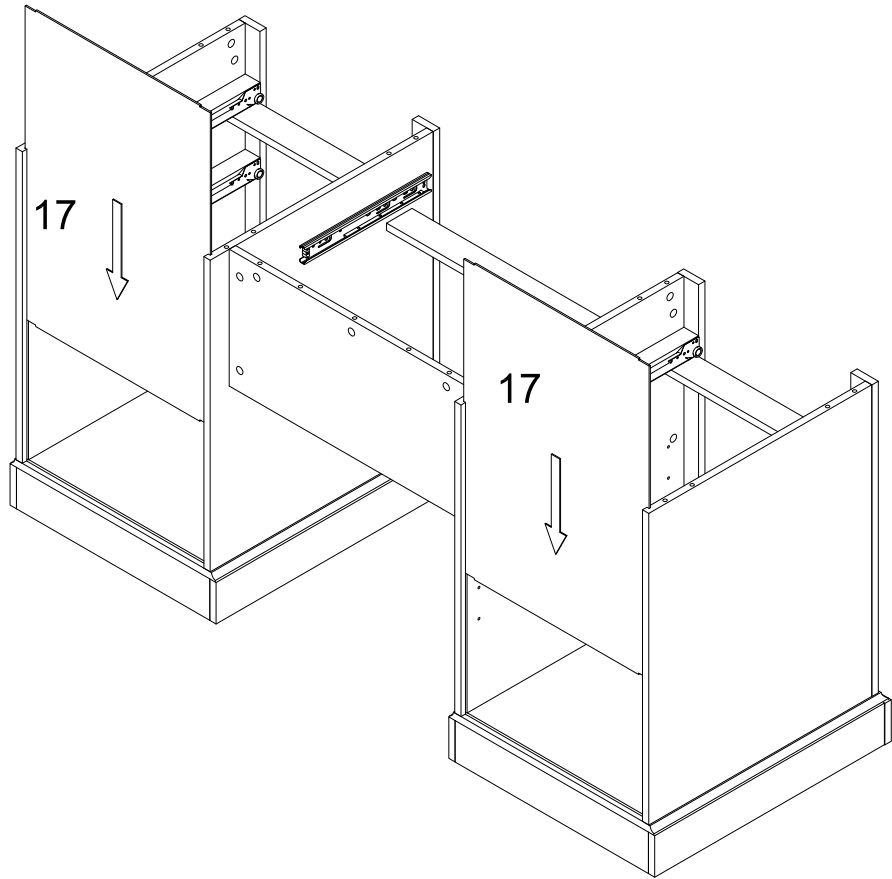

CAUTION: Heavy! You may need assistance with this step.

Step 30

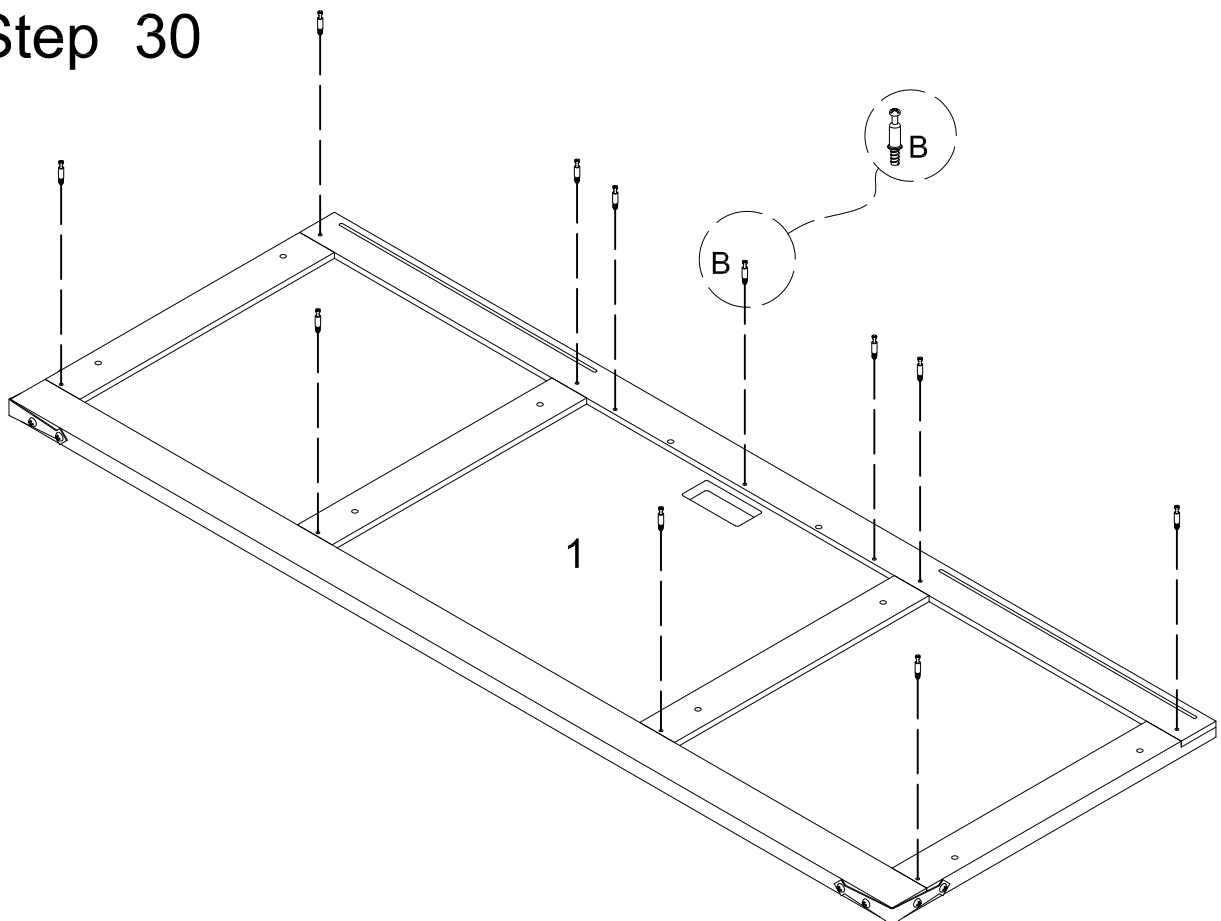

Step 31

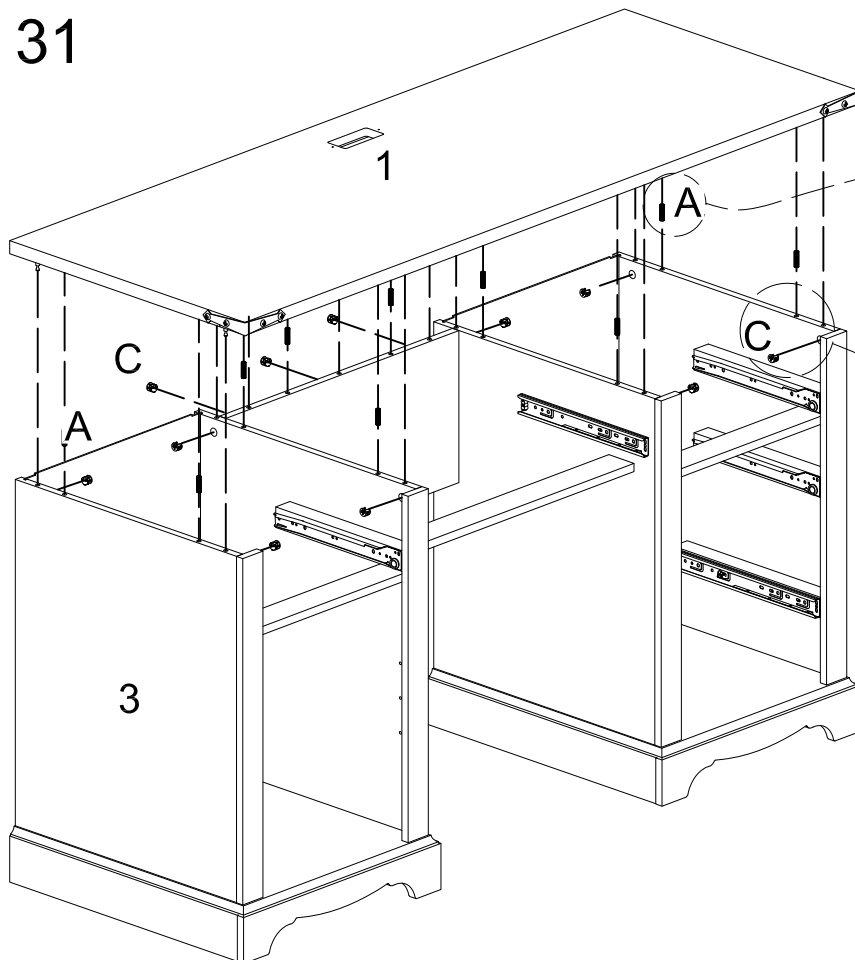

Step 32

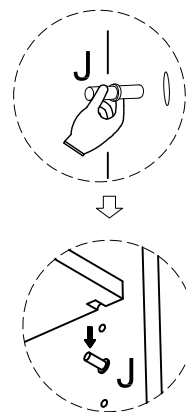
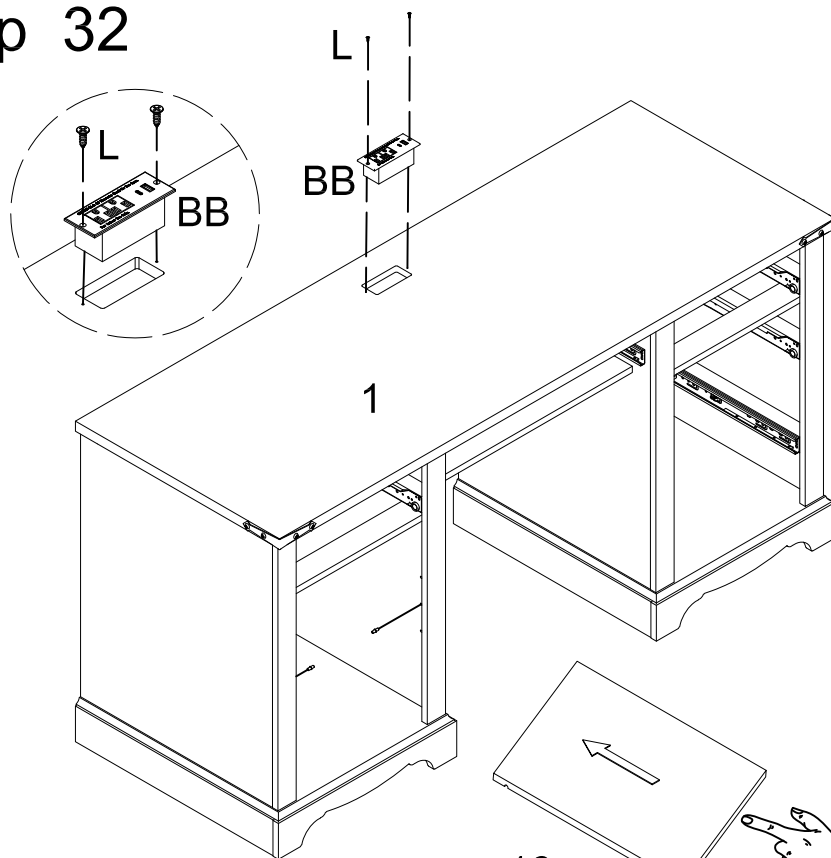

16

Finished edge

Step 33

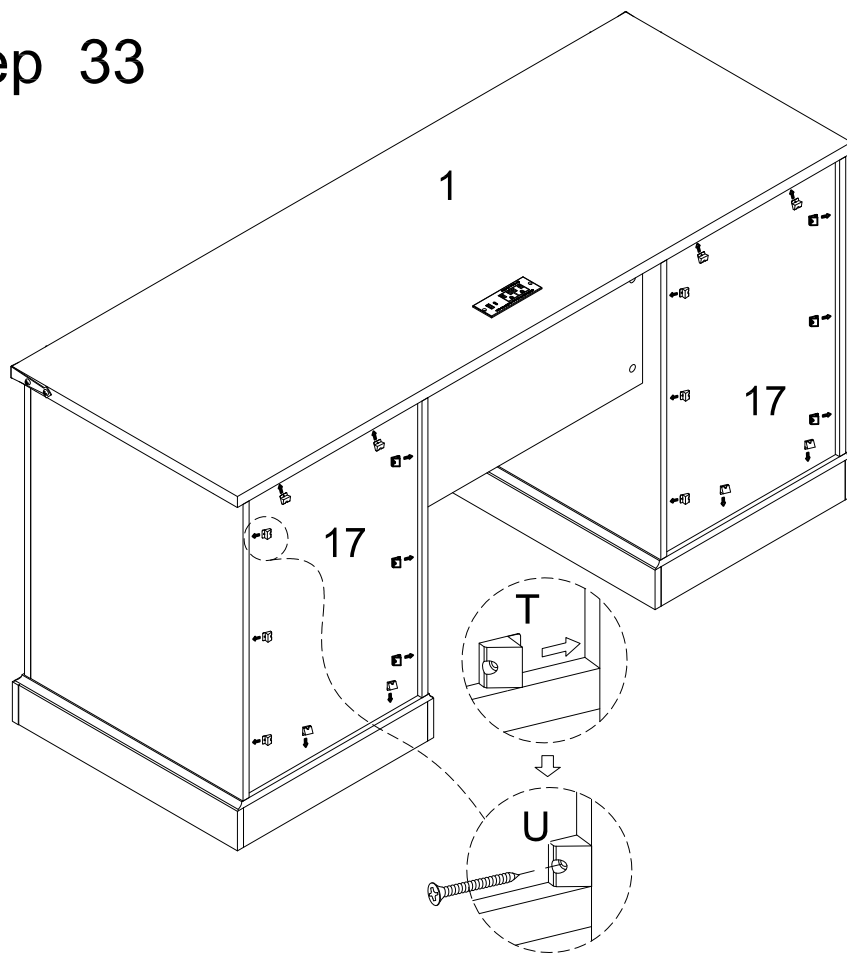

Step 34

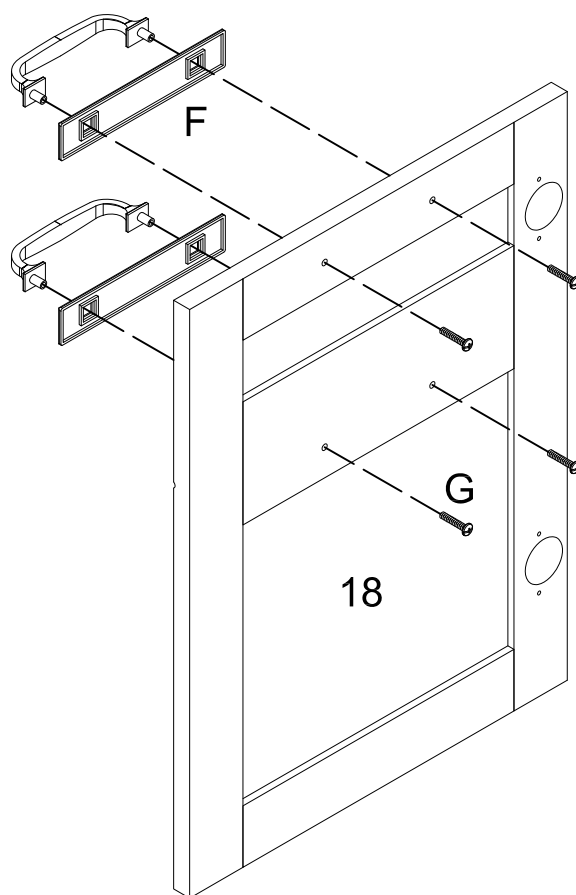

Step 35

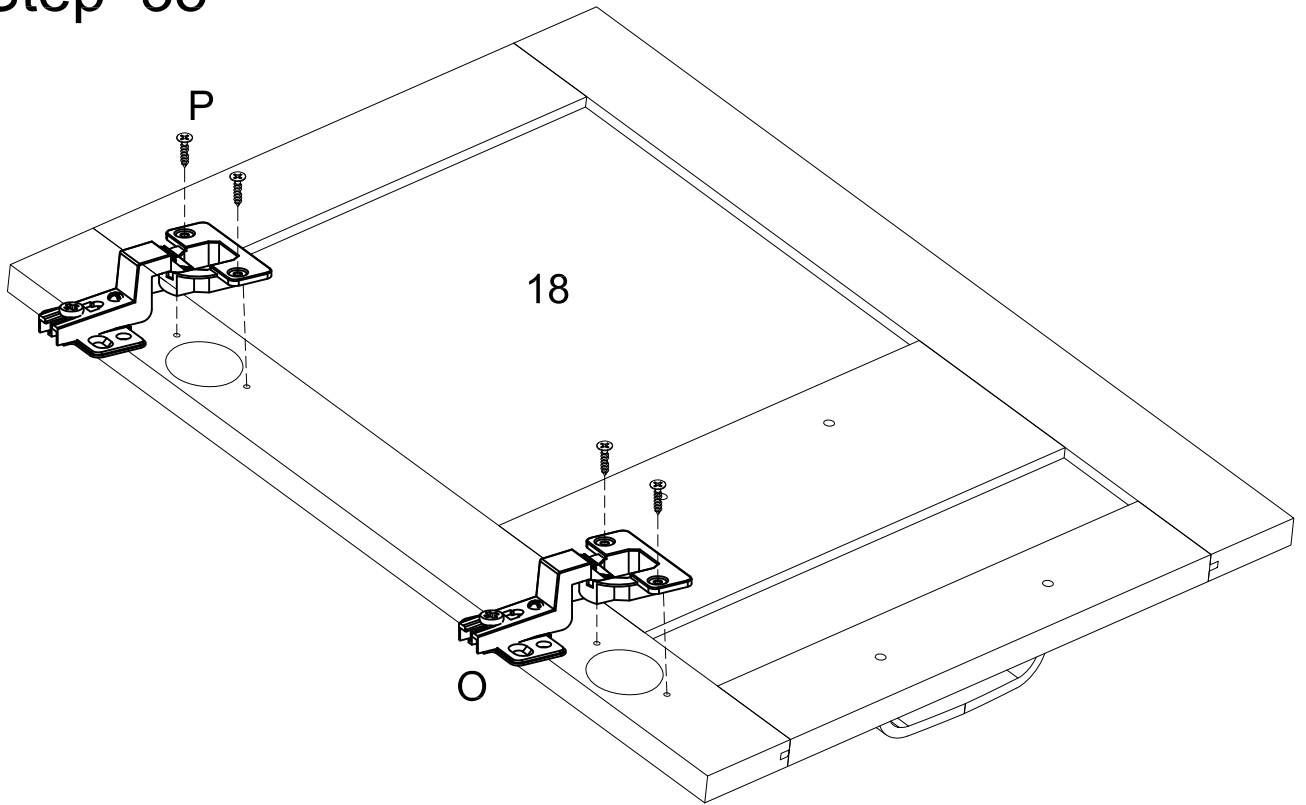

Step 36

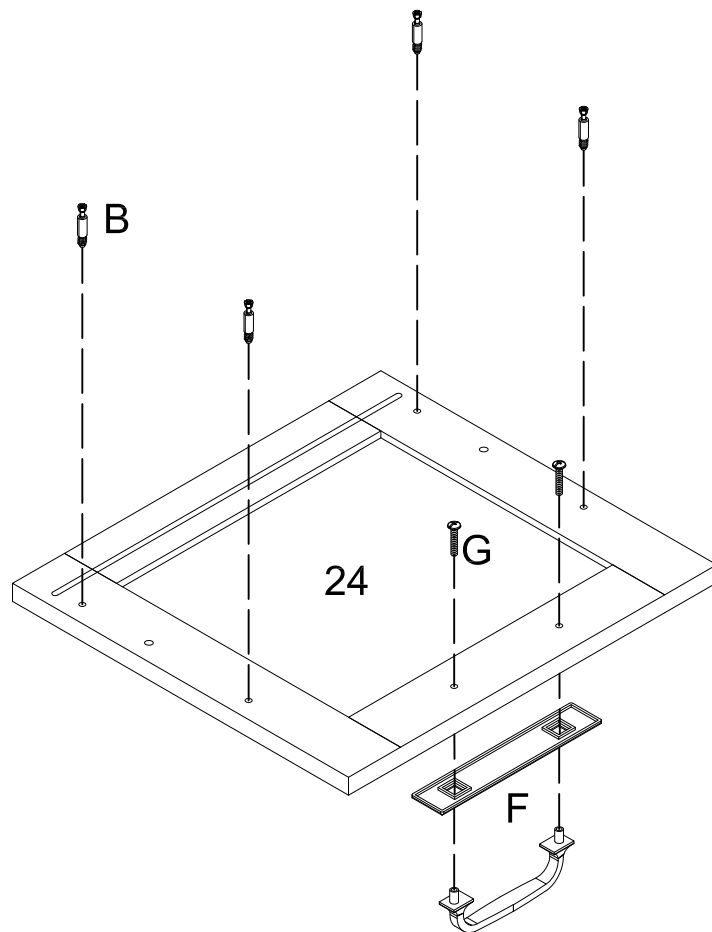

Step 37

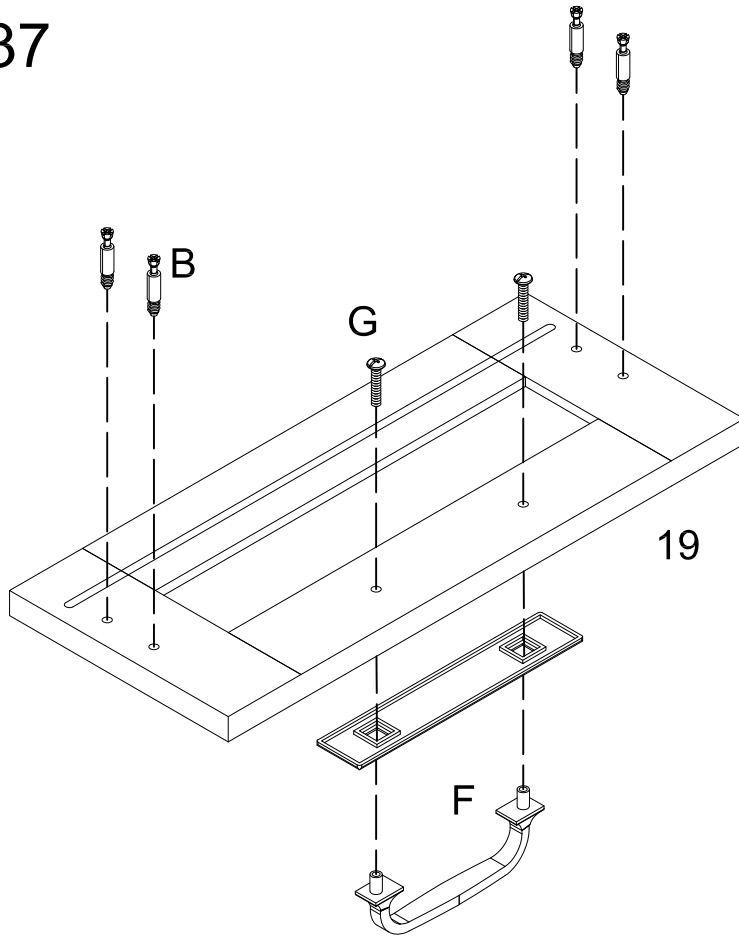

X3

Step 38

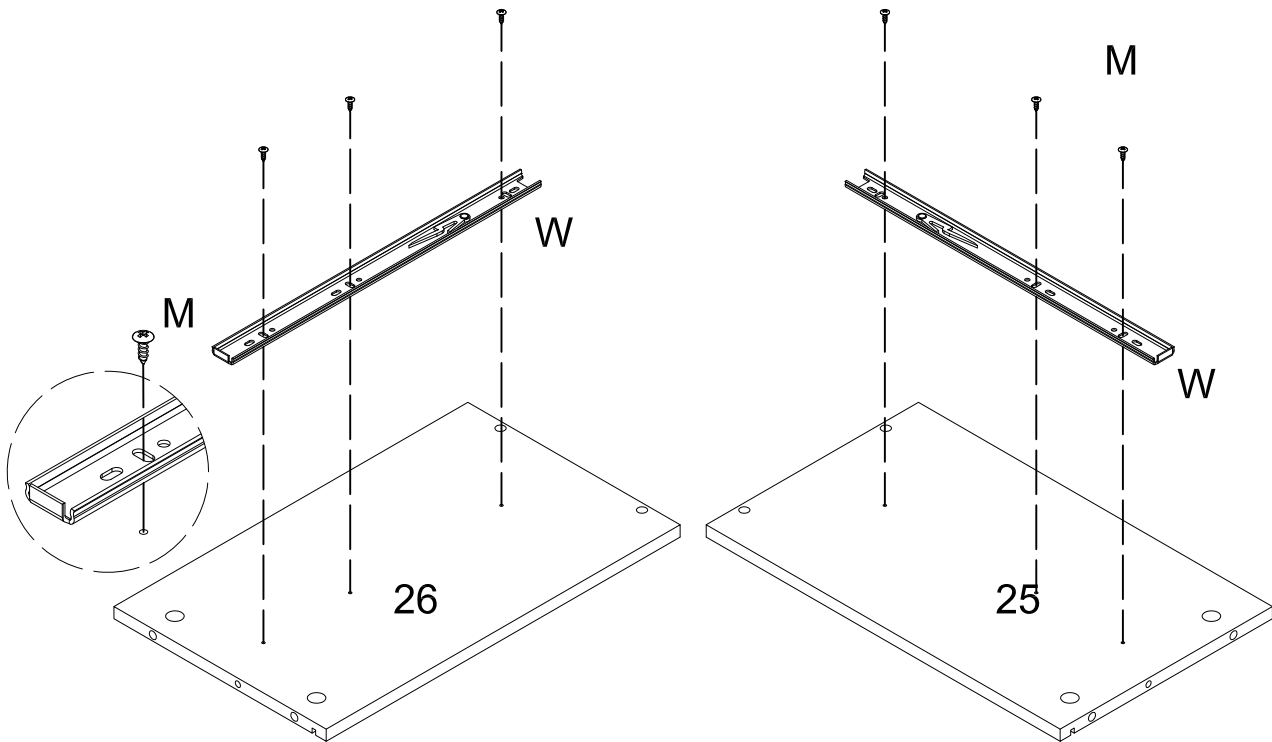

Step 39

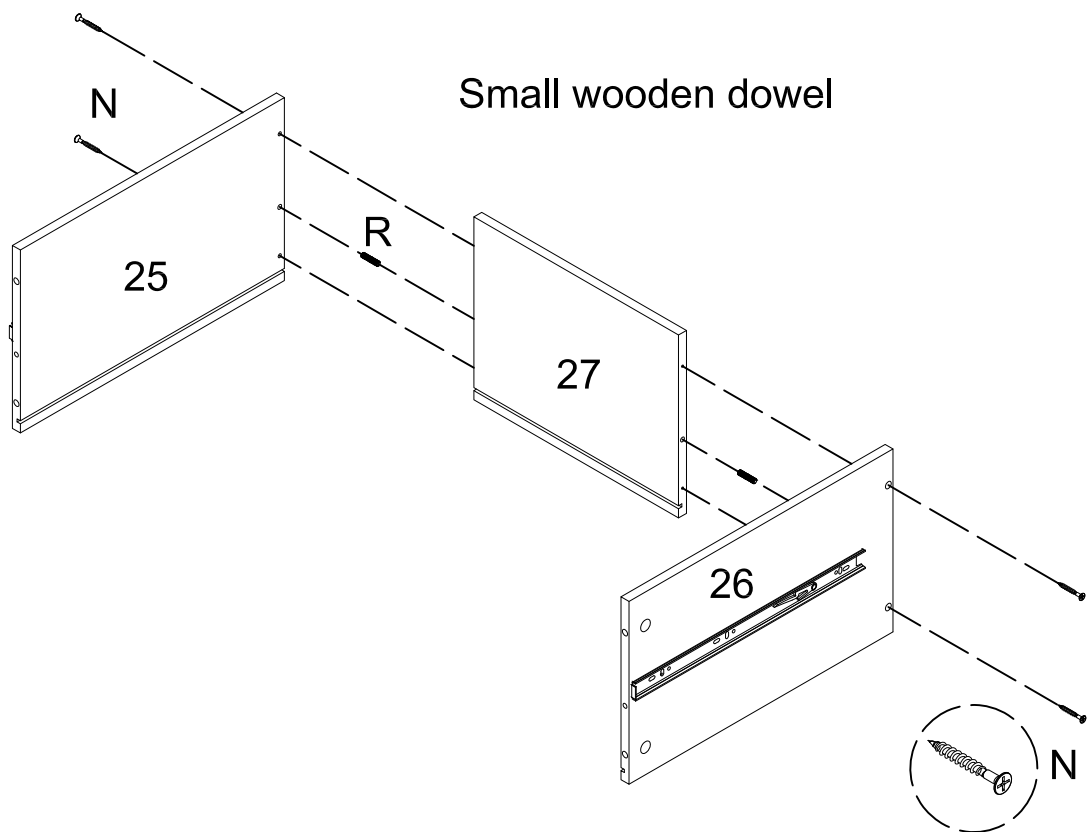

Step 40

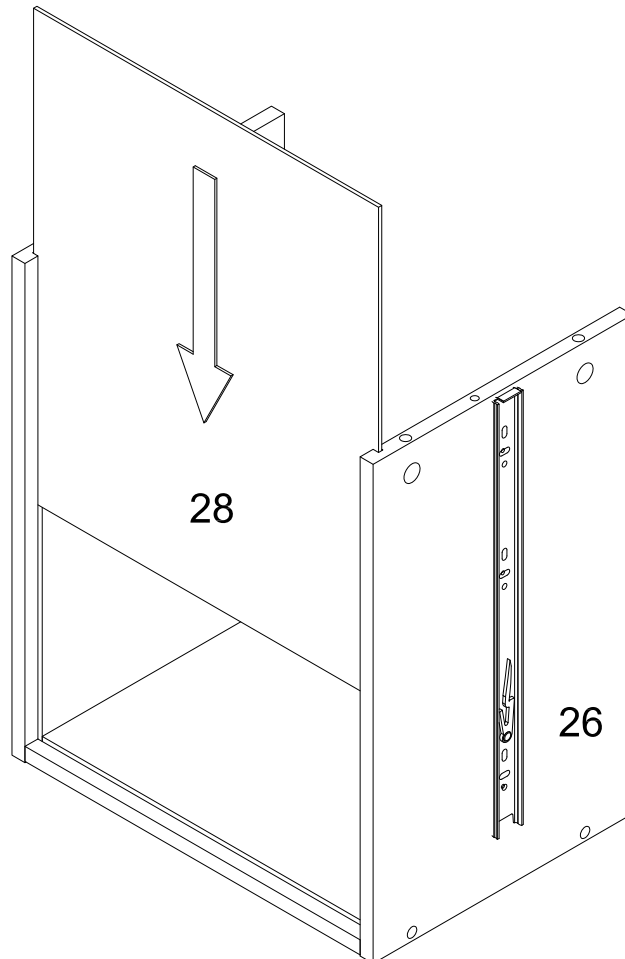

Step 41

Small wooden dowel
Small cam lock

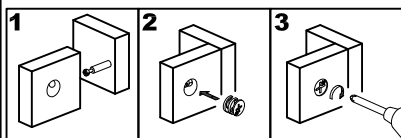
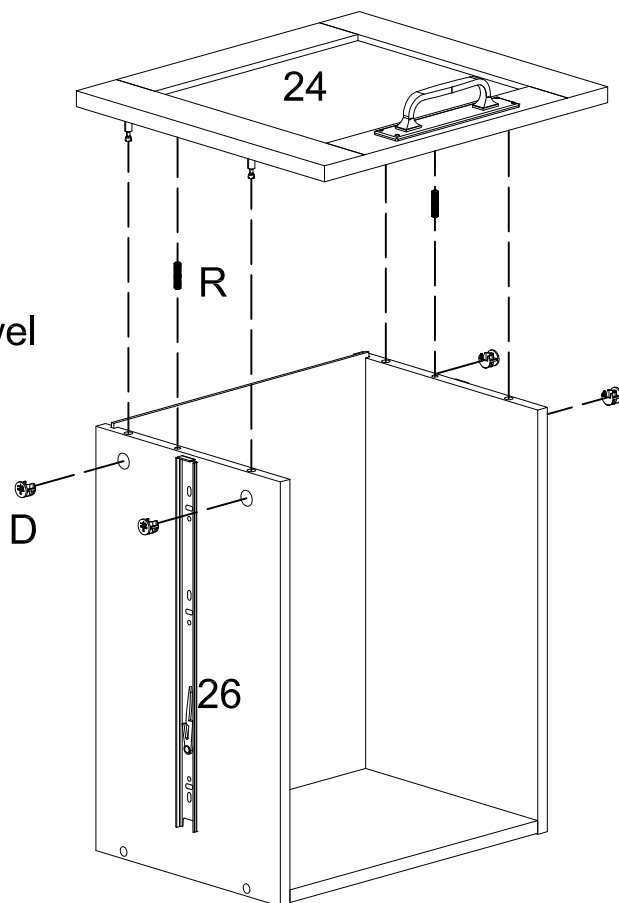

Step 42

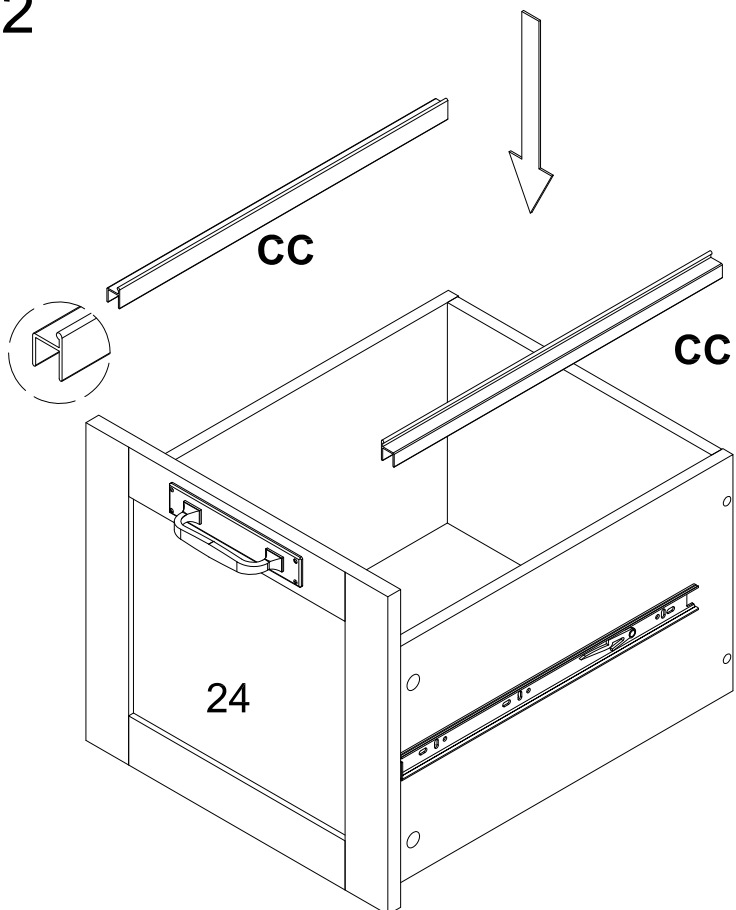

Step 43

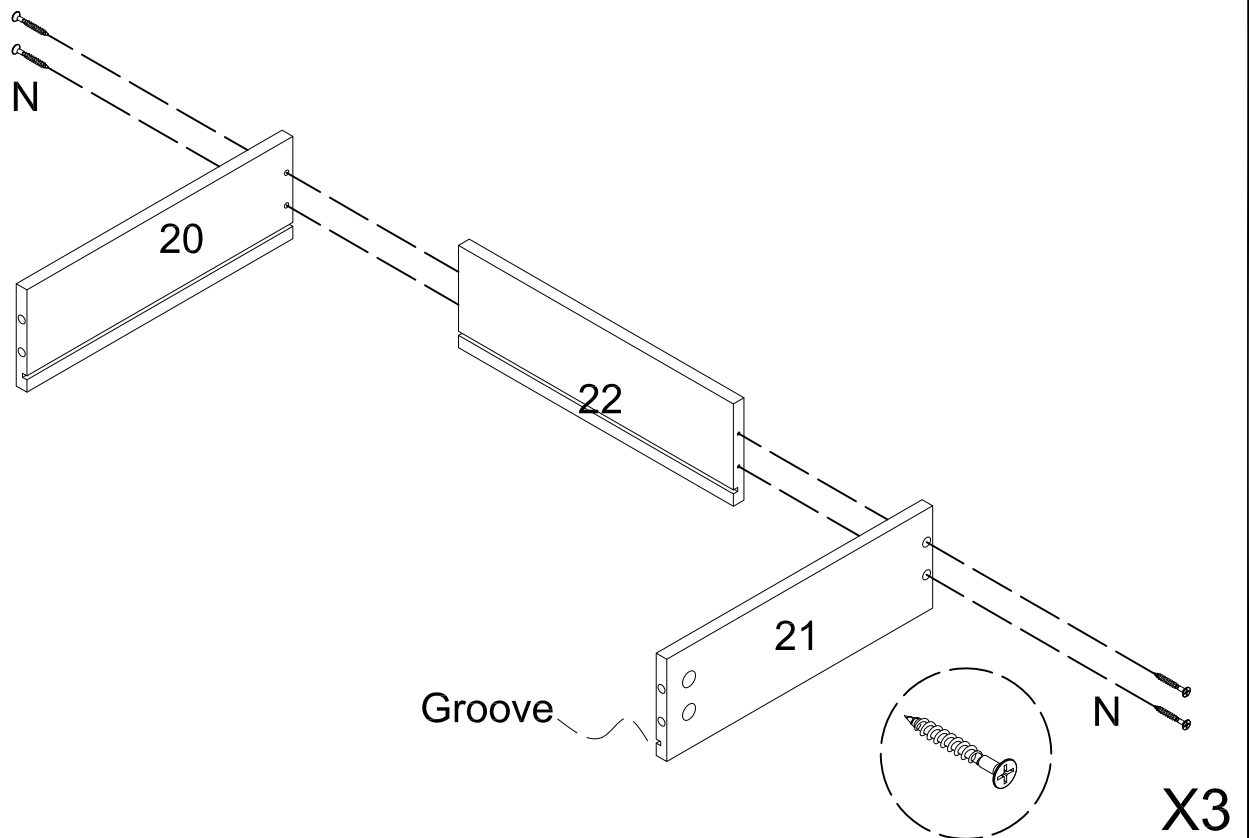

Step 44

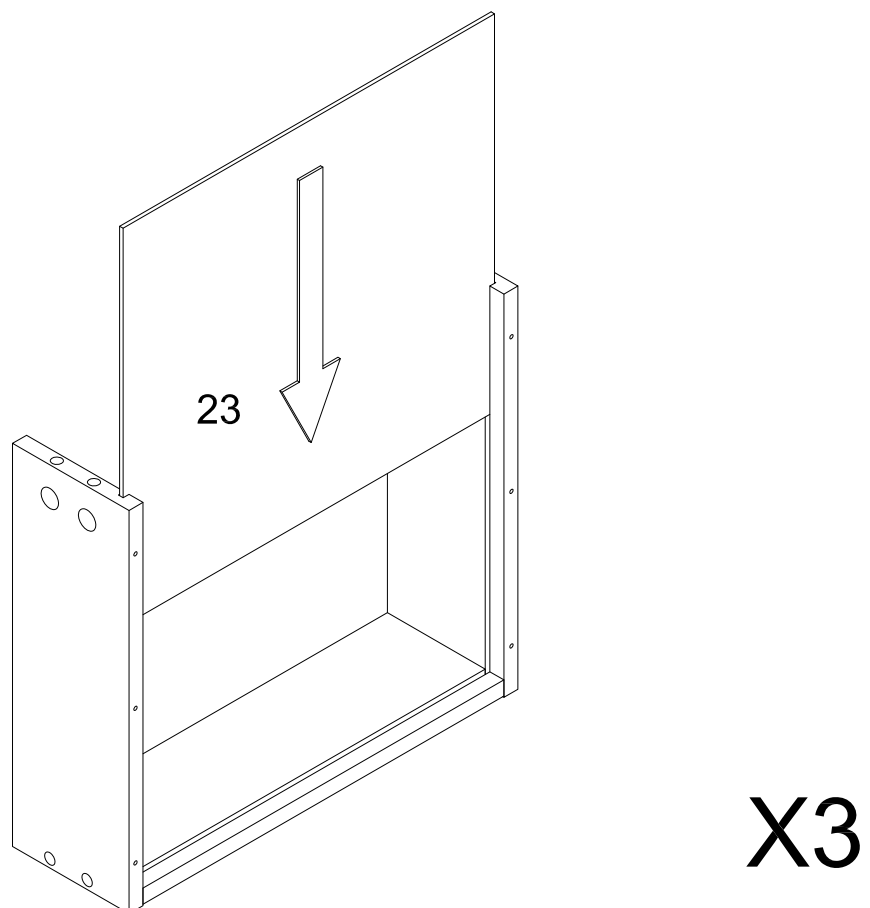

Step 45

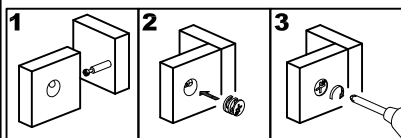
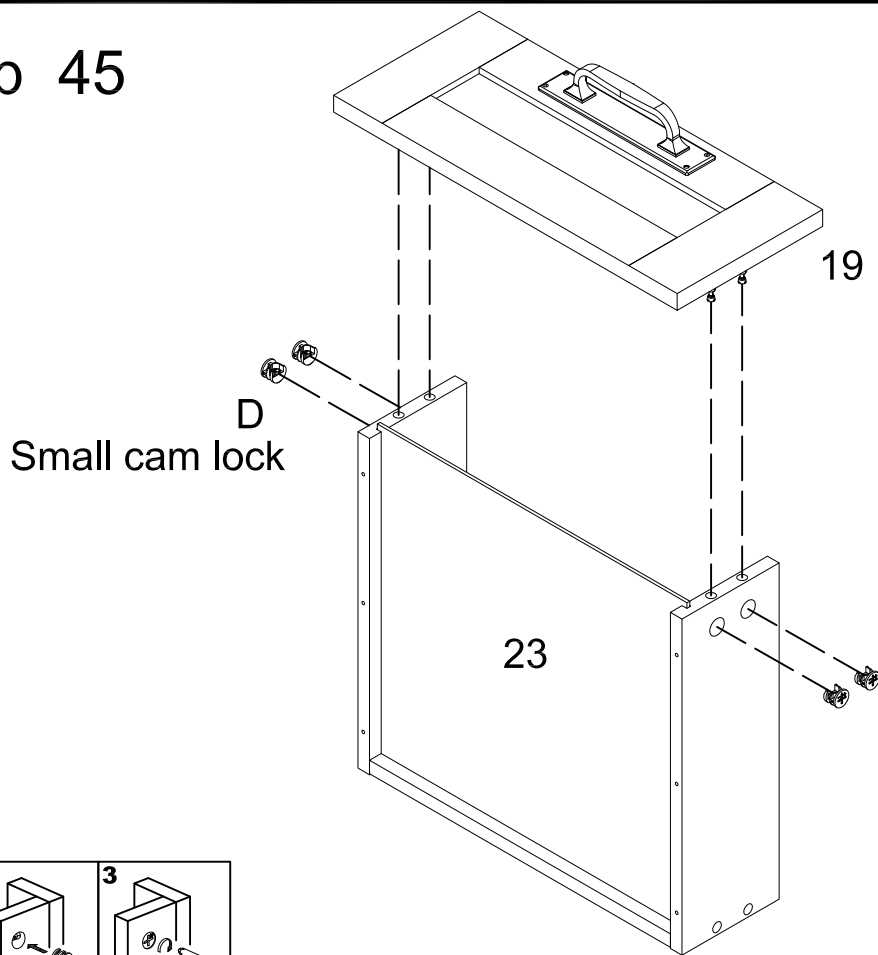

X3

Step 46

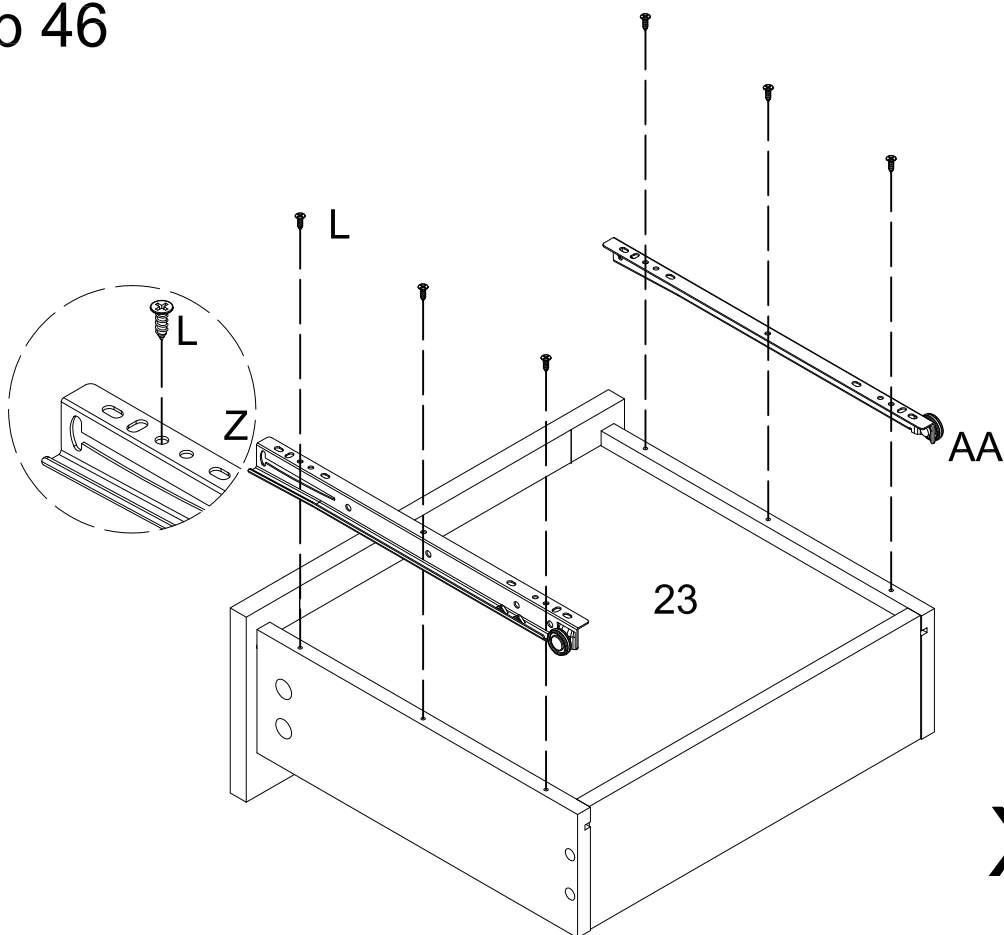

X3

Step 47

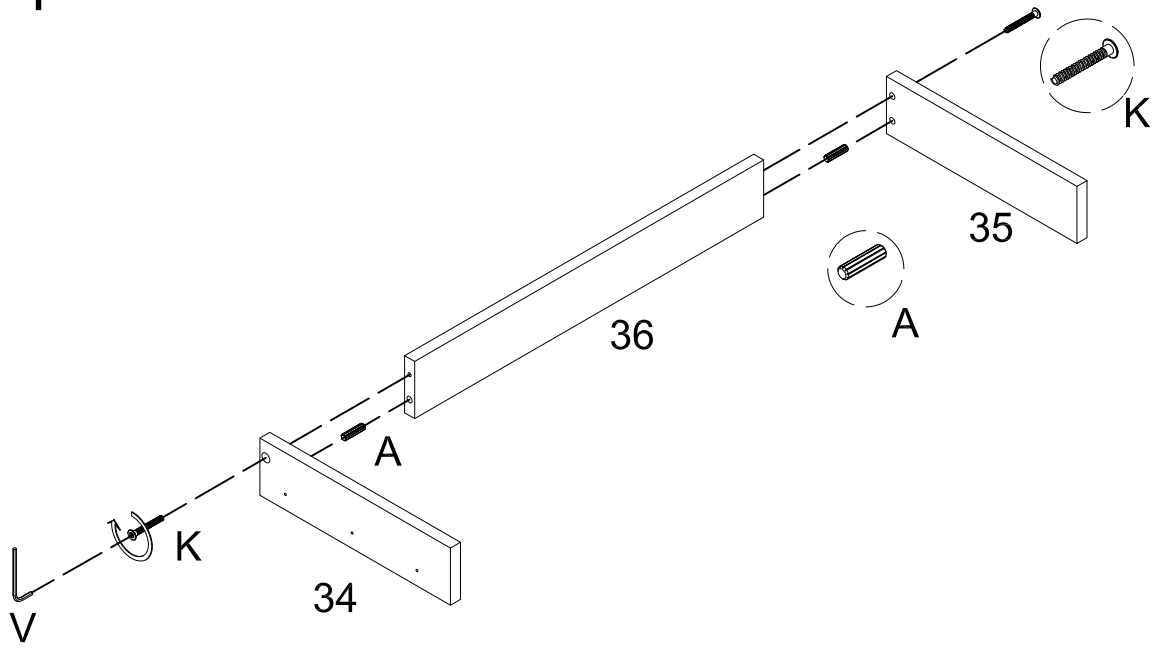

Step 48

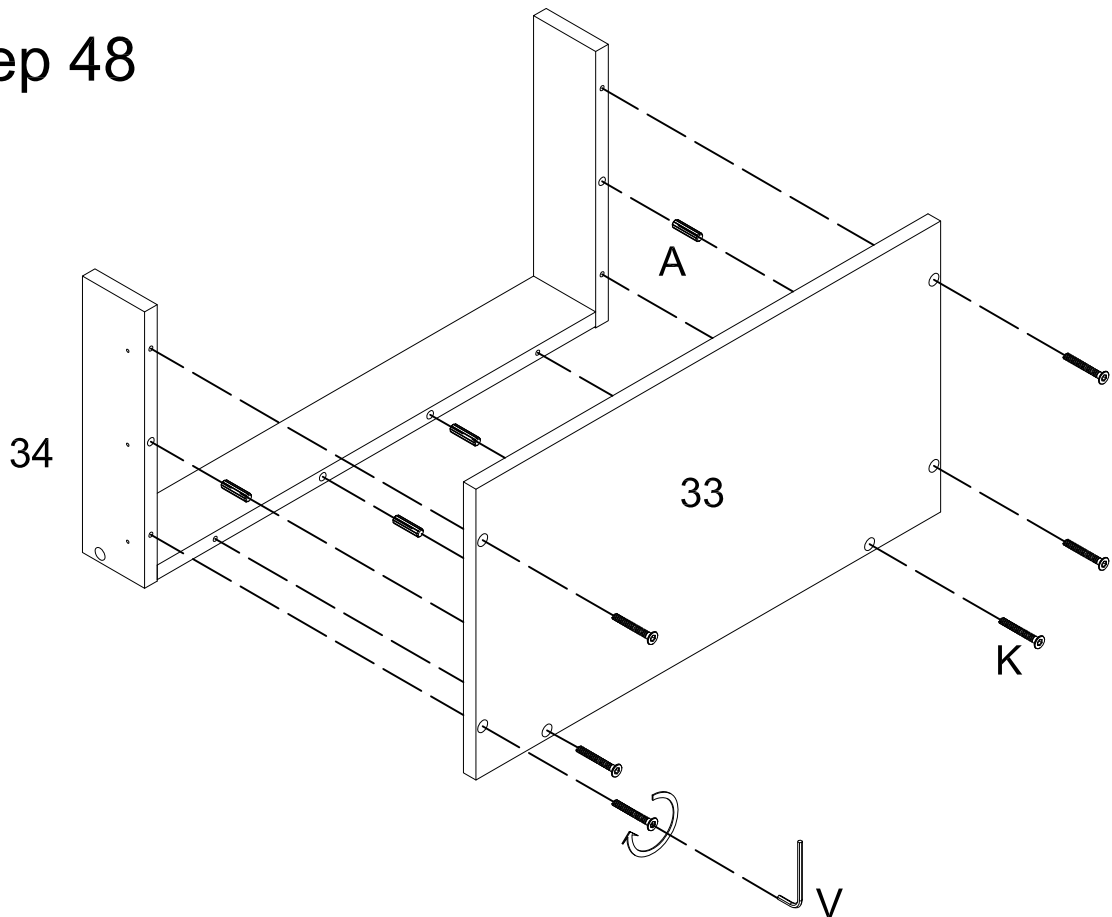

Step 49

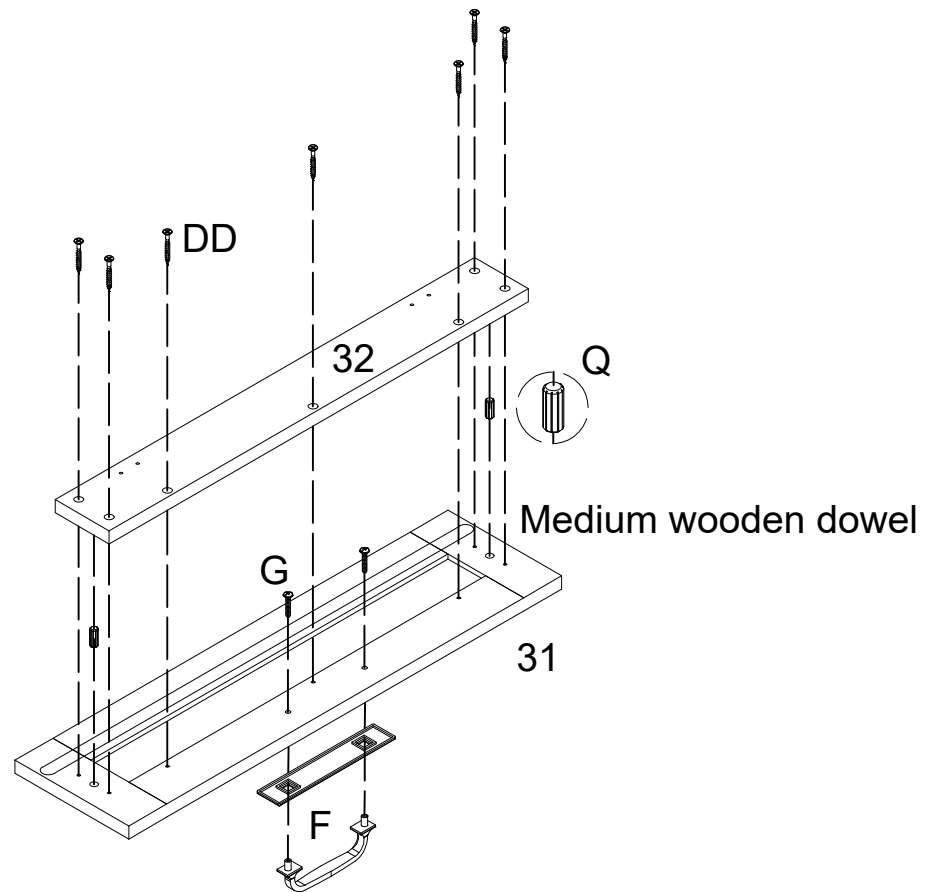

Step 50

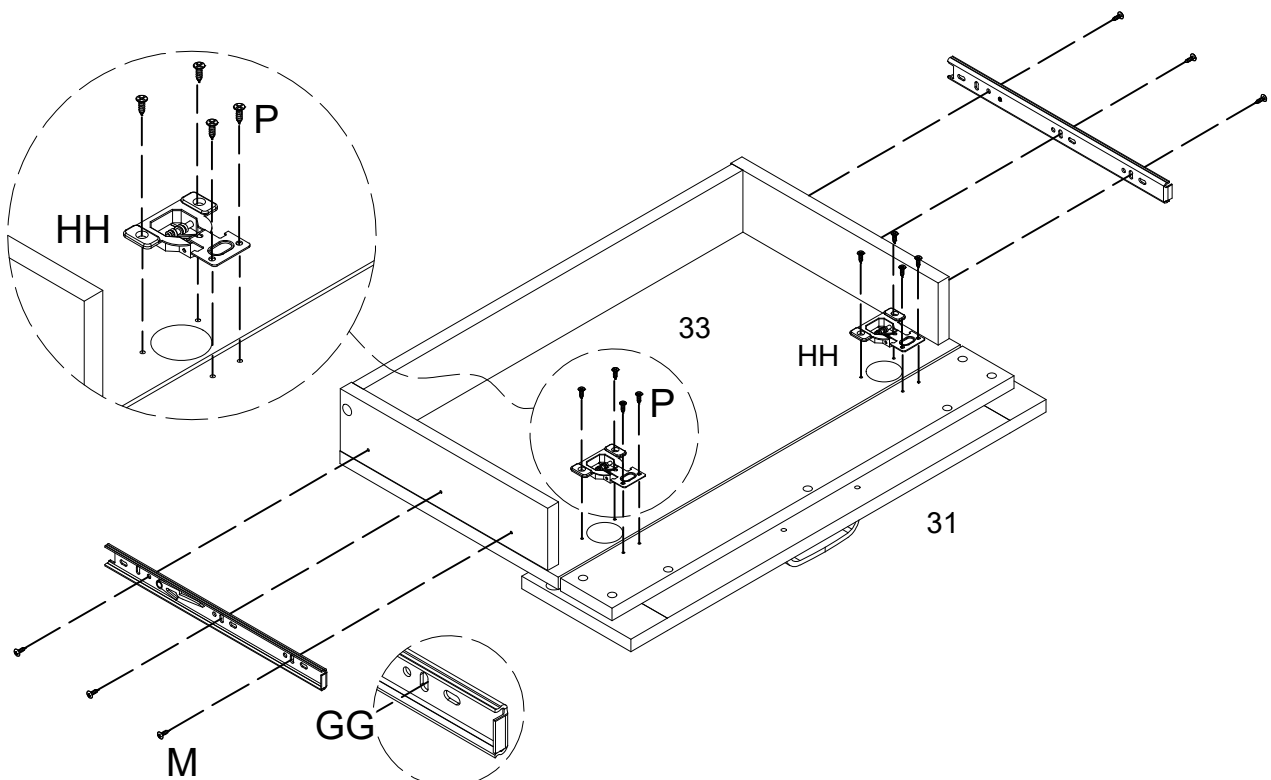

Step 51

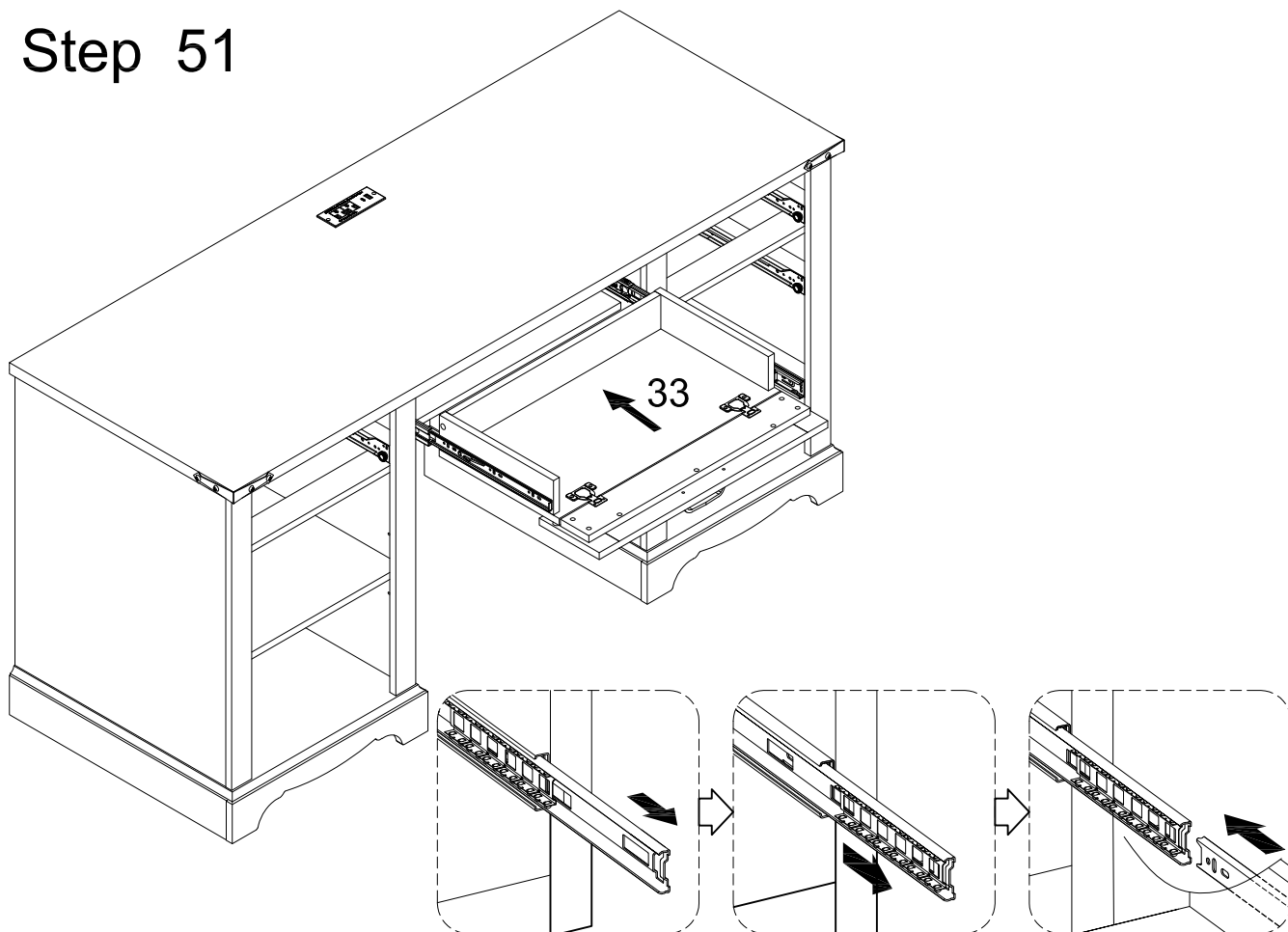

Step 52

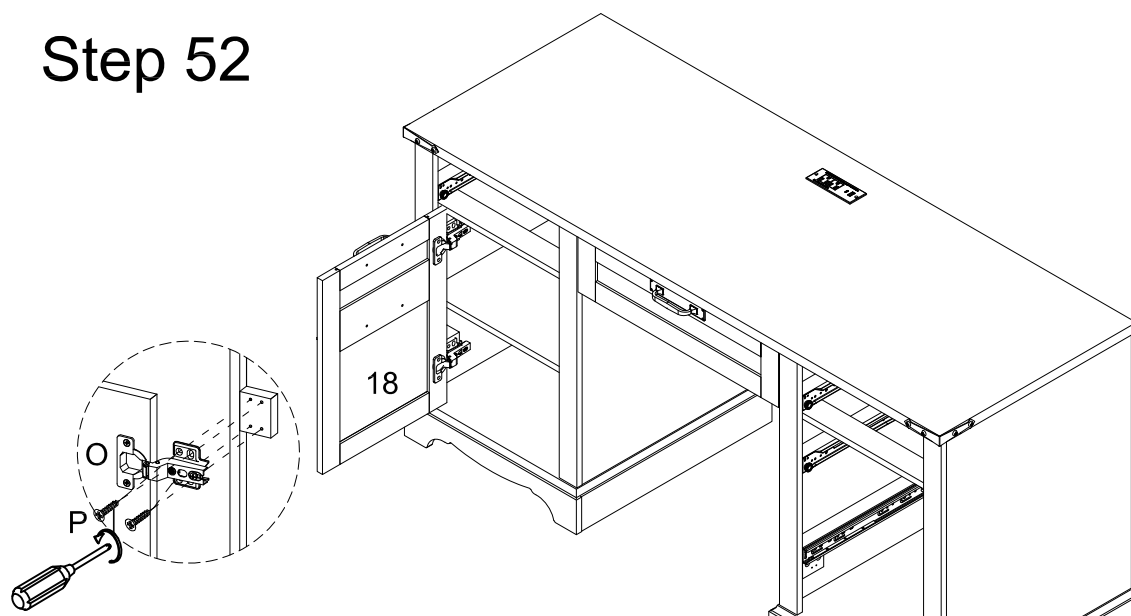

Concealed hinges are three-way adjustable.

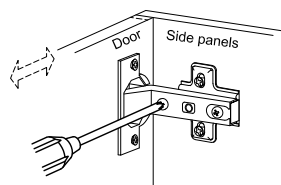

Horizontal
by screw adjustment

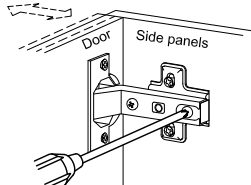

In-and-Out
by loosening the hinge-arm
mounting screw or via cam
adjustment

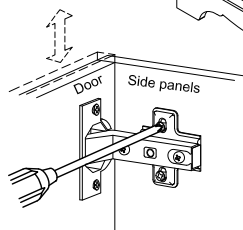

Vertical
Via slots in the mounting
plate or via cam
adjustment

Step 53

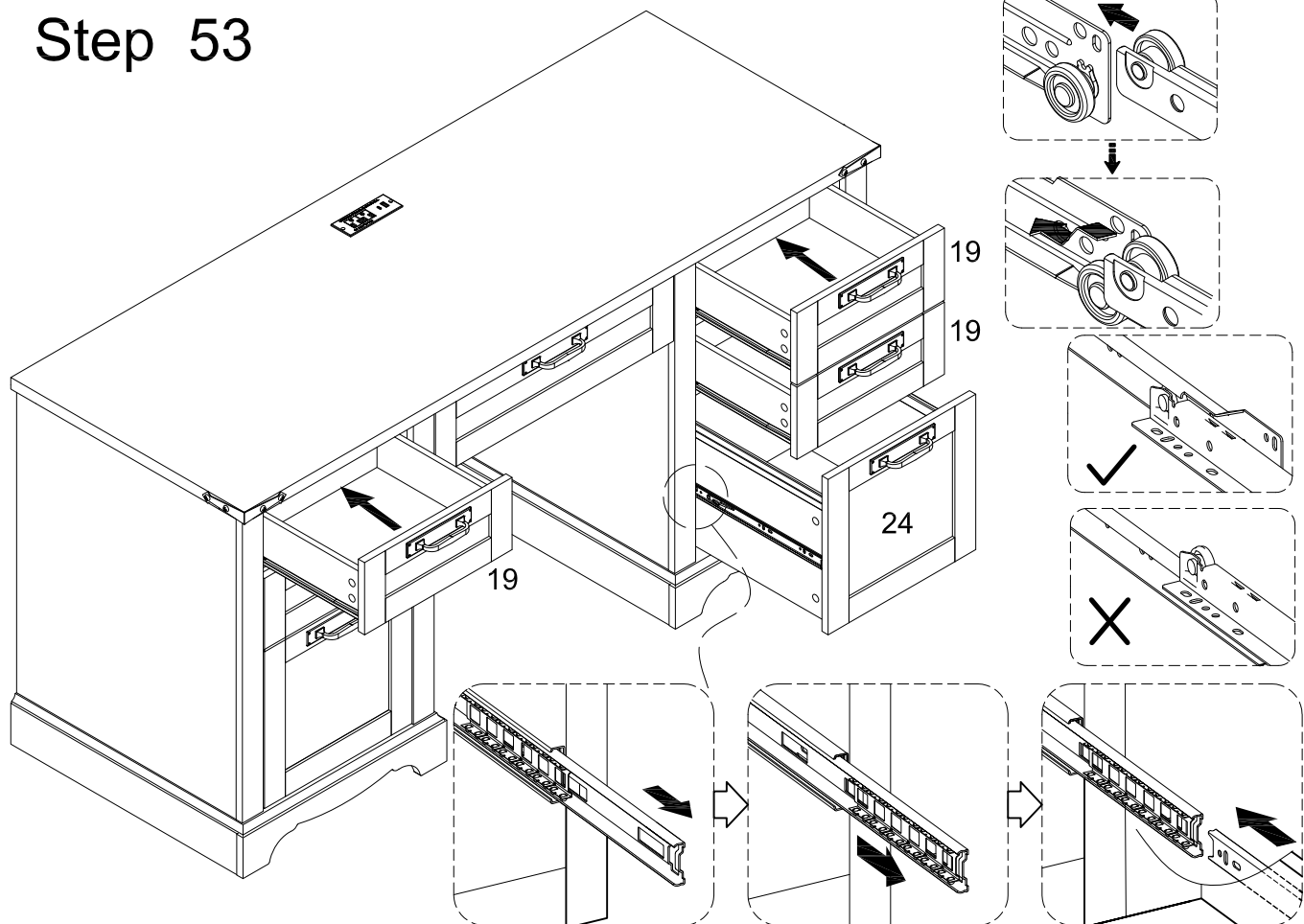

Step 54

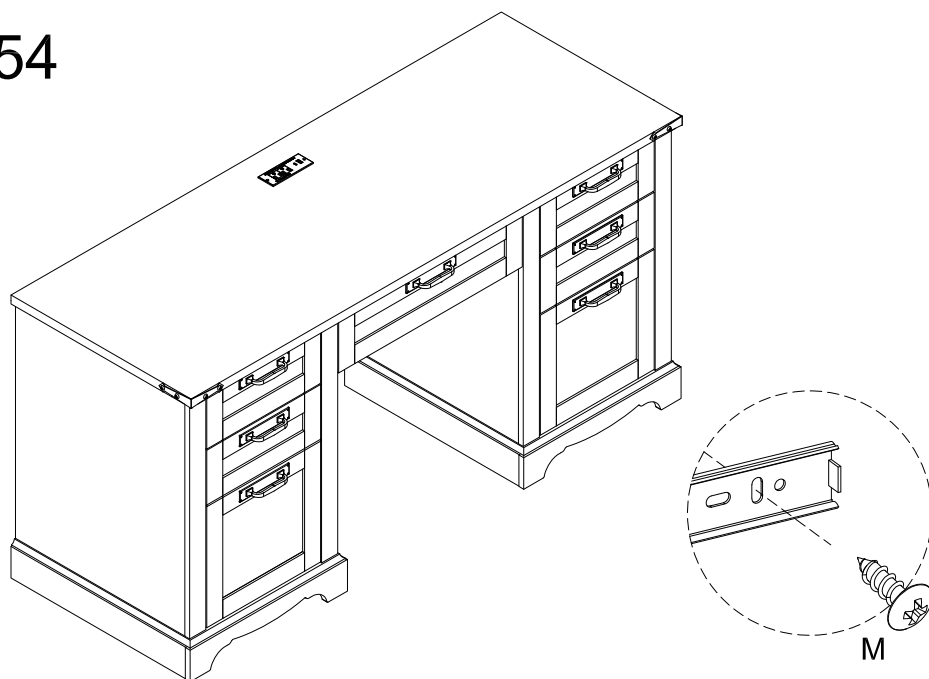

Note:

If the File drawer or Keyboard drawer does not go in smoothly. Press or lift the plastic release lever. Pull out the slider bracket from the slider arm. Loosen the screws(M) on slider brackets, You can adjust up or down by a few mm. Then tighten back up. Finally re-assembled the drawer until they were going in smoothly well.

Step 55



Final Assembly

Step 56

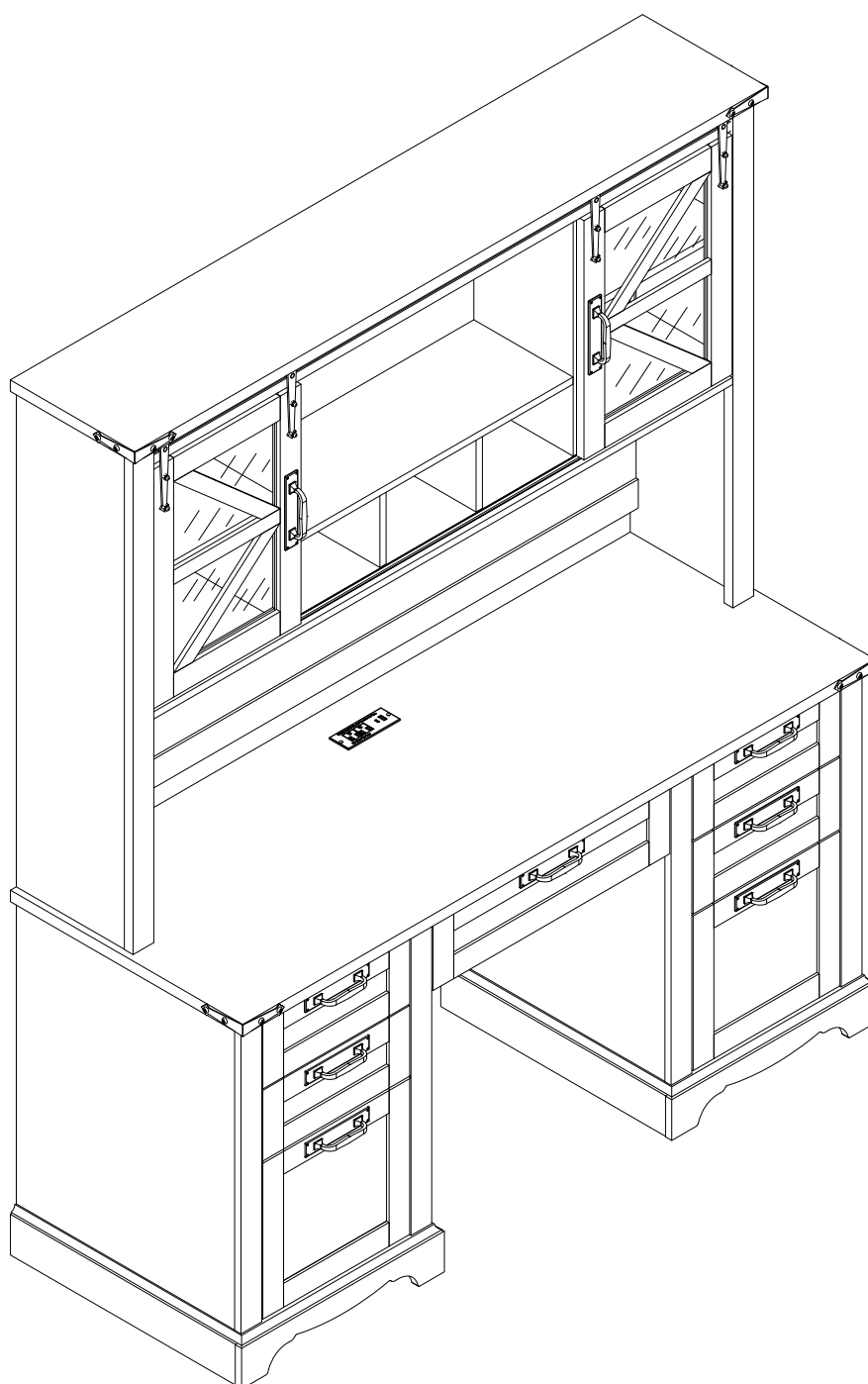

Matching hutch is available online