

## Bed Frame

---

Dimension: 199\*141\*96cm

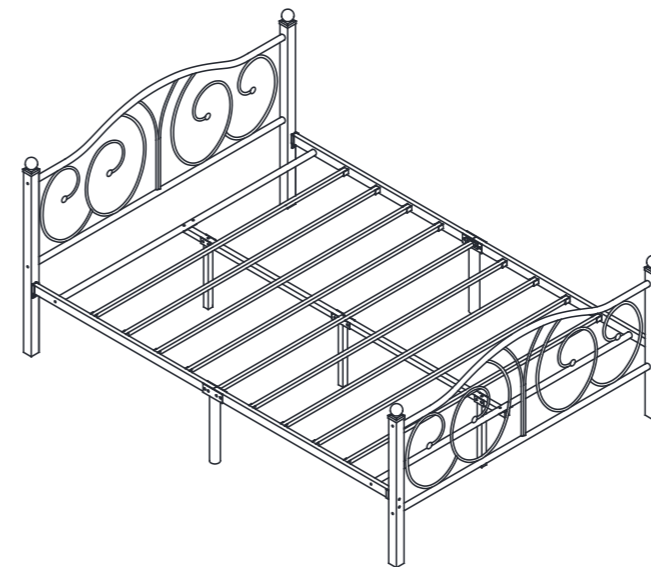

Item Description: Bed Frame

Dimension: 199\*141\*96cm

Model NO: \_\_\_\_\_

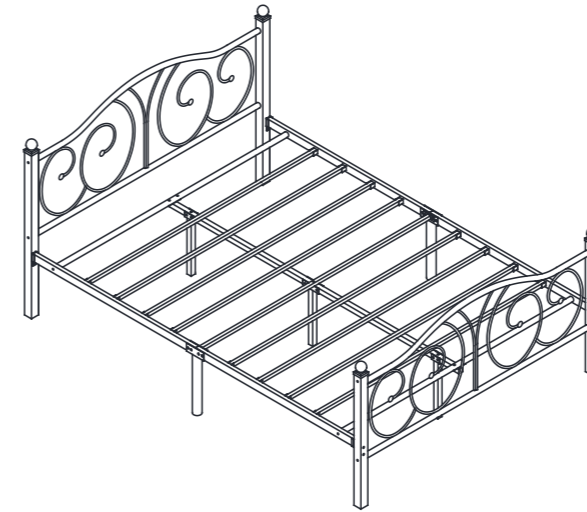

Dimension: 199\*141\*96cm

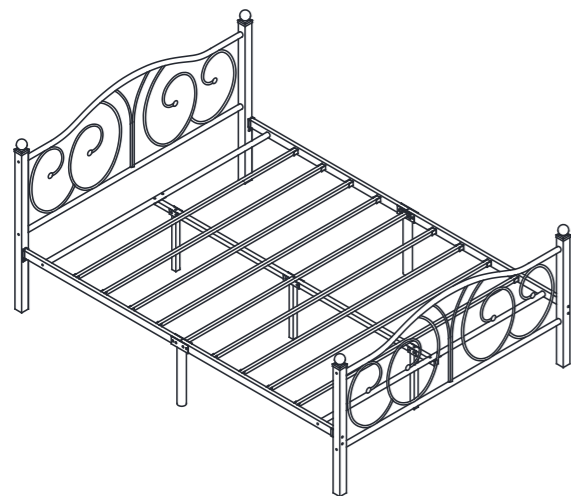

Item Description: Bettrahmen

Dimension: 199\*141\*96cm

Model NO: \_\_\_\_\_

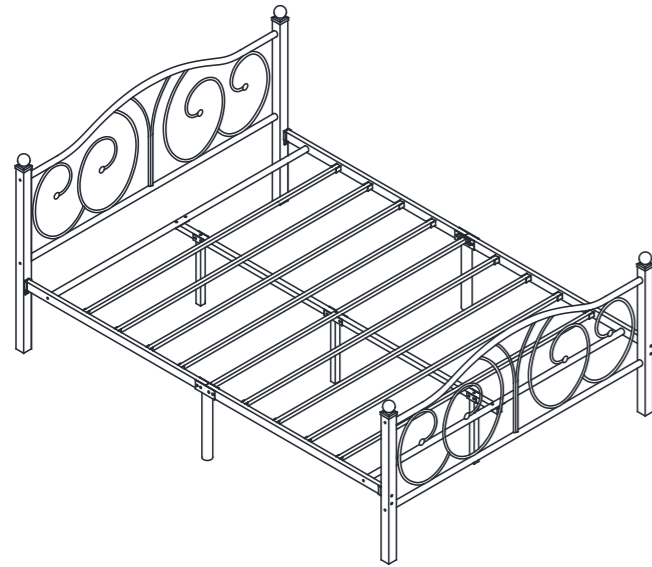

Dimension: 199\*141\*96cm

**ATTENTION !**

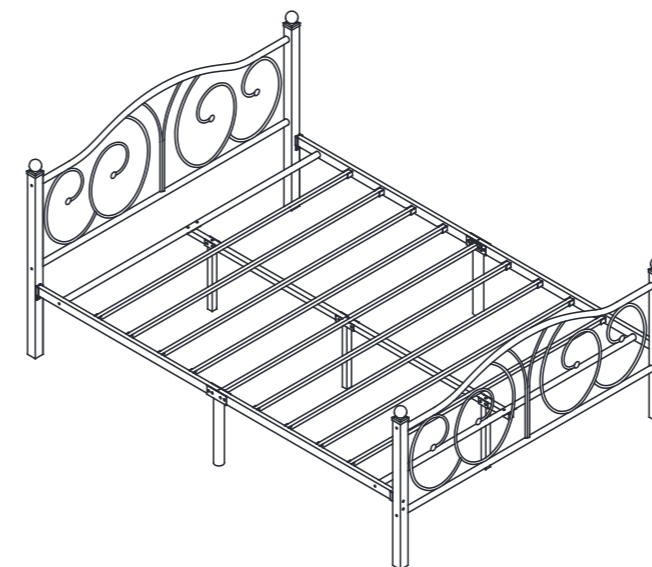
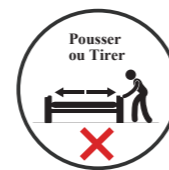
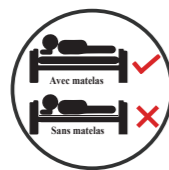
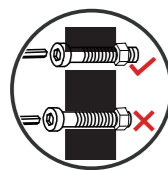

Item Description: Cadre du lit  
Dimension: 199\*141\*96cm  
Model NO: \_\_\_\_\_

● #Number System

Follow the marked steps for the easiest assembling process

step 1 step 2 step 3 step 4...

★ #Zahlensystem

Folgen Sie den markierten Schritten für den Zusammenbau auf einfachste Weise

Schritt 1 Schritt 2 Schritt 3 Schritt 4 ...

▲ Système de numération

Suivez les étapes indiquées pour faciliter le processus de montage :

étape 1, étape 2, étape 3, étape 4, etc.

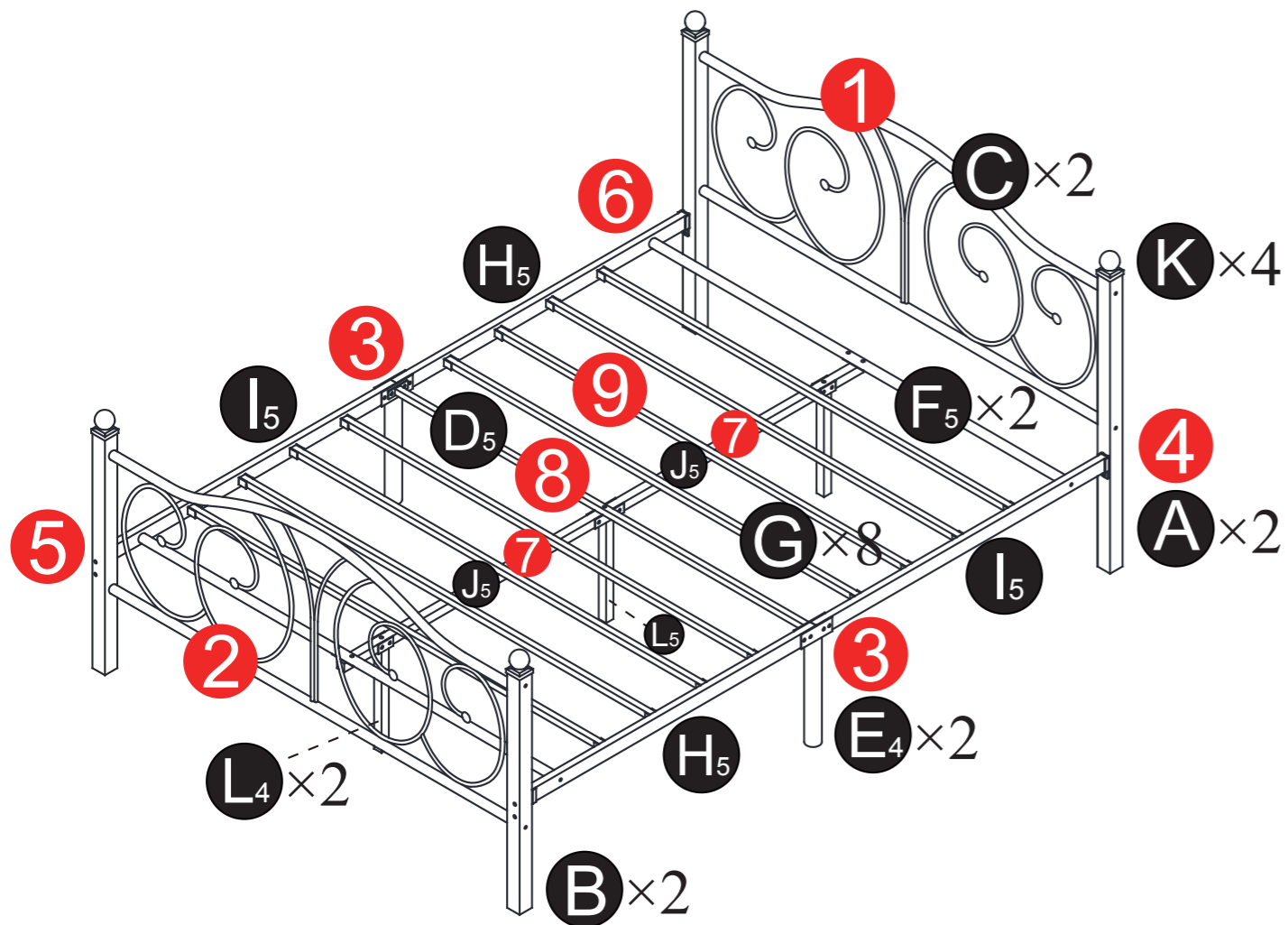





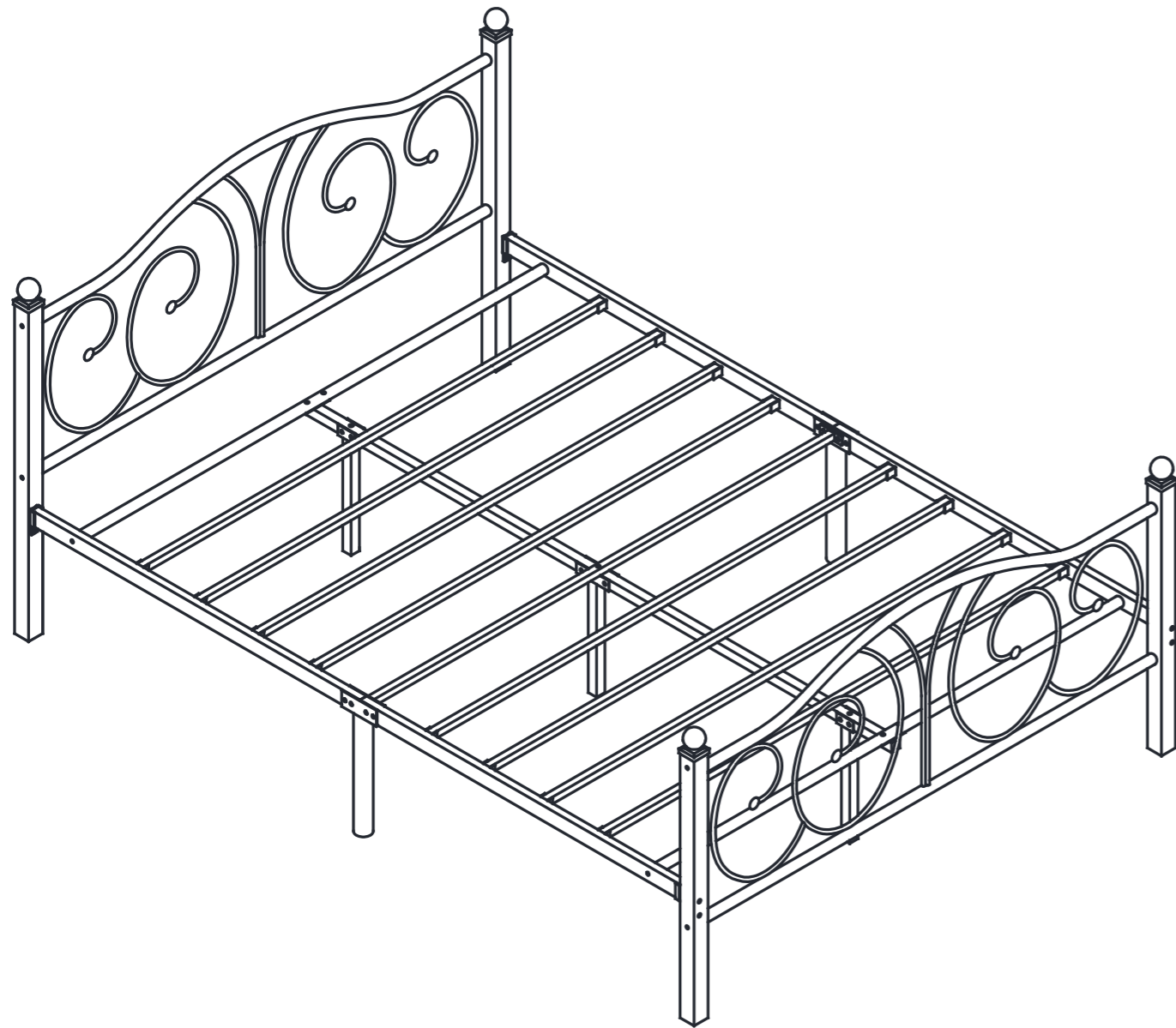



## Step 10

- Note: Now remember to double check all screws are properly fastened
- ★ Hinweis: Vergessen Sie jetzt nicht, zu überprüfen, ob alle Schrauben richtig angezogen sind.
- ▲ Remarque : N'oubliez pas de vérifier que toutes les vis sont bien serrées.



Components		Bauteile		Composants	
<b>A</b>		2pcs	<b>B</b>		2pcs
<b>C</b>		2pcs	<b>D<sub>5</sub></b>		1pcs
<b>E<sub>4</sub></b>		2pcs	<b>F<sub>5</sub></b>	 ● With Screw Holes ★ Mit Schraubenlöchern ▲ Avec trous de vis	2pcs
<b>G</b>	 ● Without Screw Holes ★ Ohne Schraubenlöcher ▲ Sans trous de vis	8pcs	<b>H<sub>5</sub></b>		2pcs
<b>I<sub>5</sub></b>		2pcs	<b>J<sub>5</sub></b>		2pcs
<b>K</b>		4pcs	<b>L<sub>4</sub></b>		2pcs
<b>L<sub>5</sub></b>		1pcs			

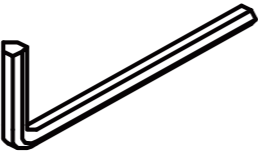
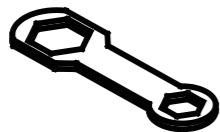

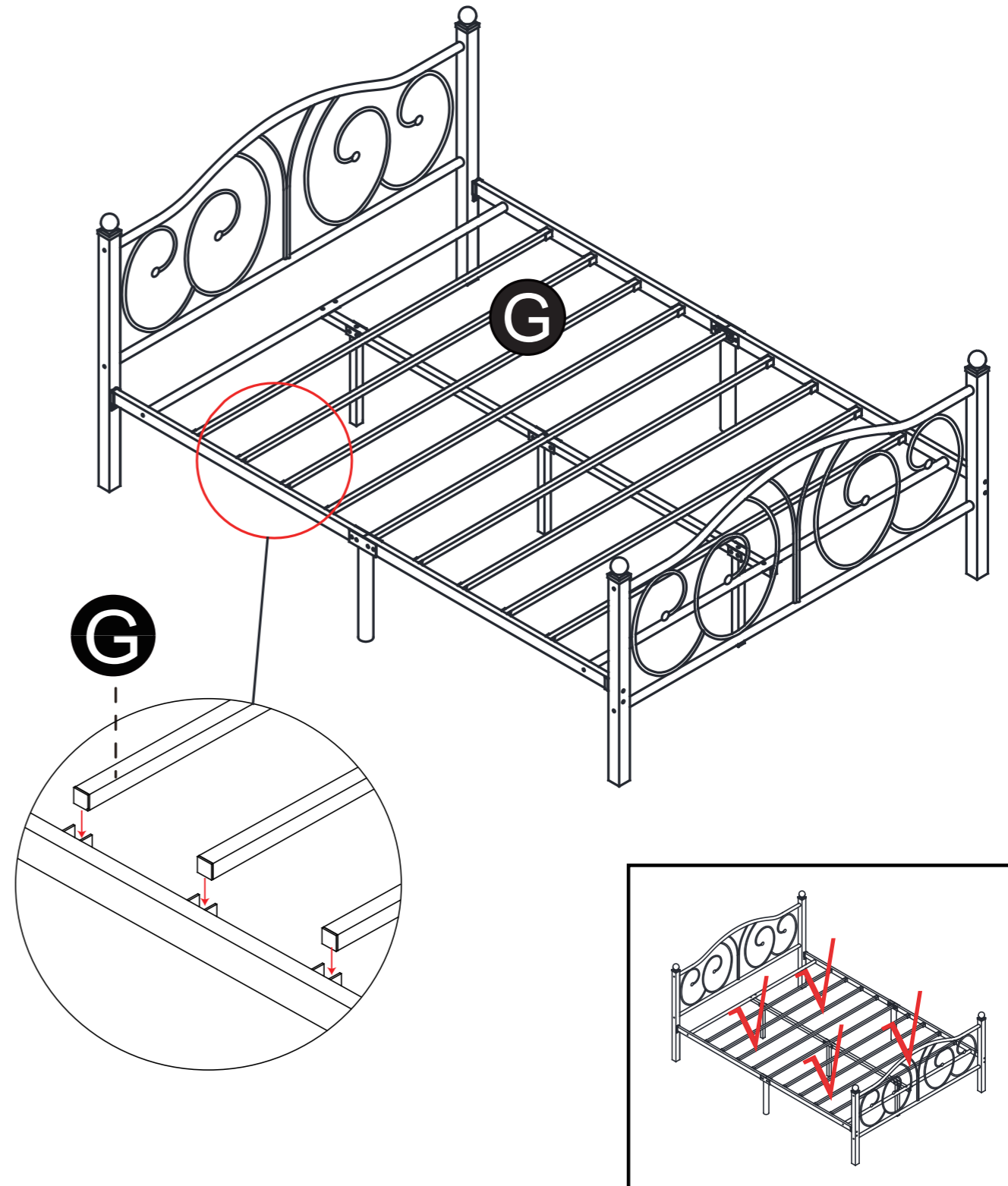

<b>1</b>	 M8X50mm	8pcs	<b>2</b>	 M8X35mm	8pcs
<b>3</b>	 M6X60mm	9pcs	<b>4</b>	 M6X40mm	12pcs
<b>5</b>	 M6X30mm	4pcs	<b>6</b>	 M6X15mm	4pcs
<b>7</b>	 16pcs	<b>8</b>	 M8	12pcs	
<b>9</b>	 M6	10pcs	<b>10</b>	 M5	1pcs
<b>11</b>	 M13/M10	1pcs			

## Step 9

- Note: If the bed slats can not be inserted easily, loosen the screws (step 6)
- ★ Hinweis: Wenn sich die Lattenroste nicht leicht einschieben lassen, lösen Sie die Schrauben ein wenig (Schritt 6).
- ▲ Remarque : S'il n'est pas possible d'insérer les lattes de lit facilement, desserrer les vis (étape 6).



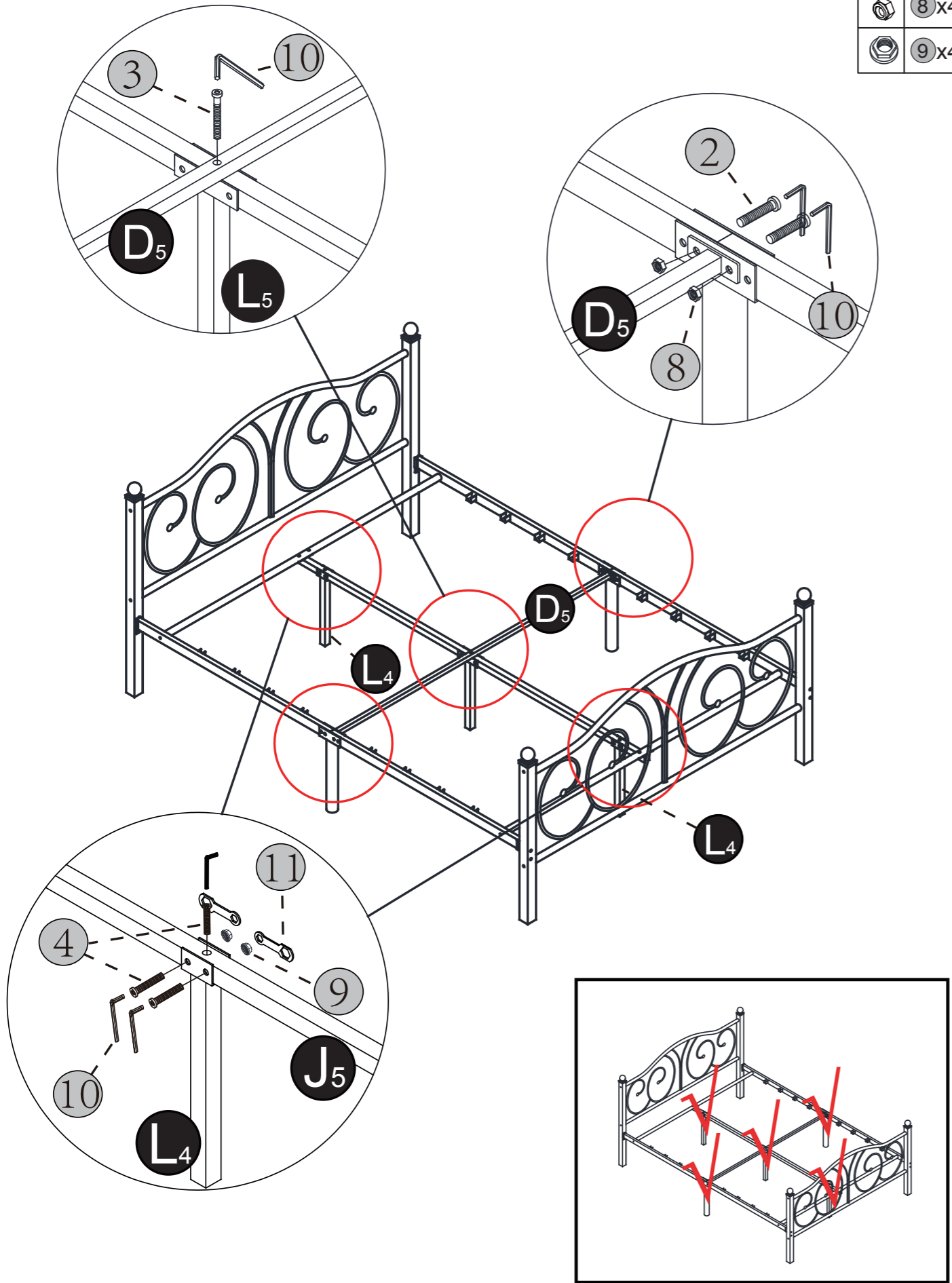

# Step 8

	2 x4
	3 x1
	4 x6
	8 x4
	9 x4



# Step 1

	3 x4
	7 x4

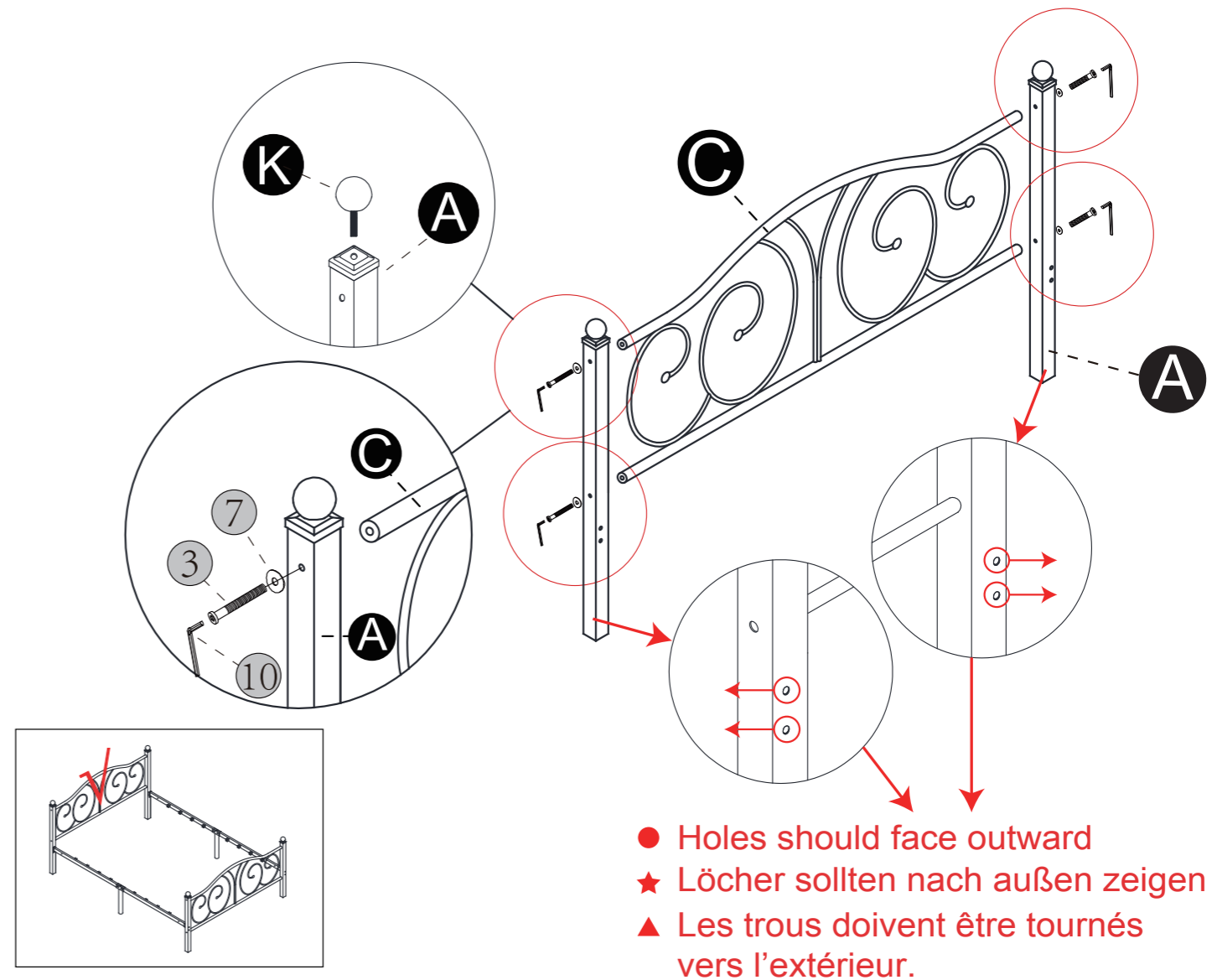

● Holes should face outward  
 ★ Löcher sollten nach außen zeigen  
 ▲ Les trous doivent être tournés vers l'extérieur.

- Note:  
Do not fully tighten screw ③ yet
- ★ Hinweis:  
Ziehen Sie Schraube ③ noch nicht ganz fest.
- ▲ Remarque :  
Ne pas encore serrer la vis ③ à fond.

# Step 2

	3 x 4
	7 x 4

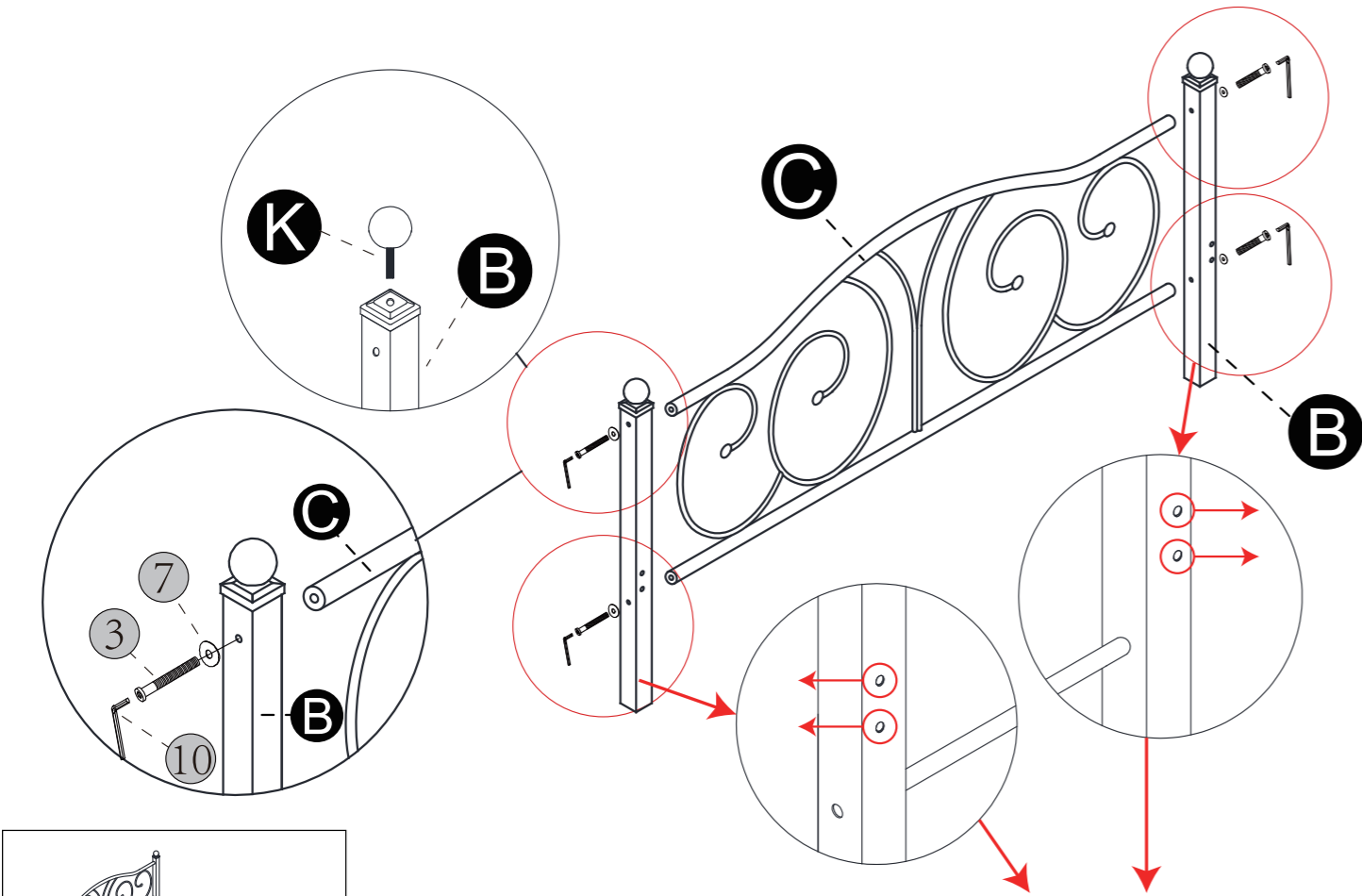

- Holes should face outward
- ★ Löcher sollten nach außen zeigen
- ▲ Les trous doivent être tournés vers l'extérieur.

- Note:  
Do not fully tighten screw ③ yet
- ★ Hinweis:  
Ziehen Sie Schraube ③ noch nicht ganz fest.
- ▲ Remarque :  
Ne pas encore serrer la vis ③ à fond.

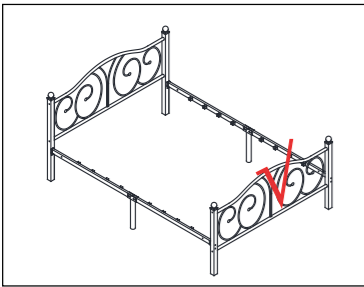

# Step 7

	4 x 2
	5 x 4
	9 x 6

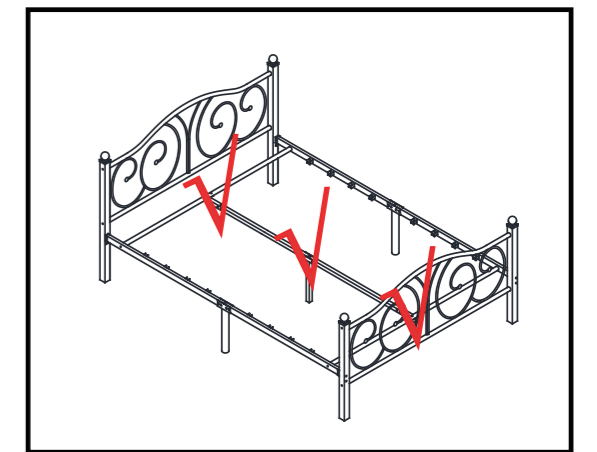
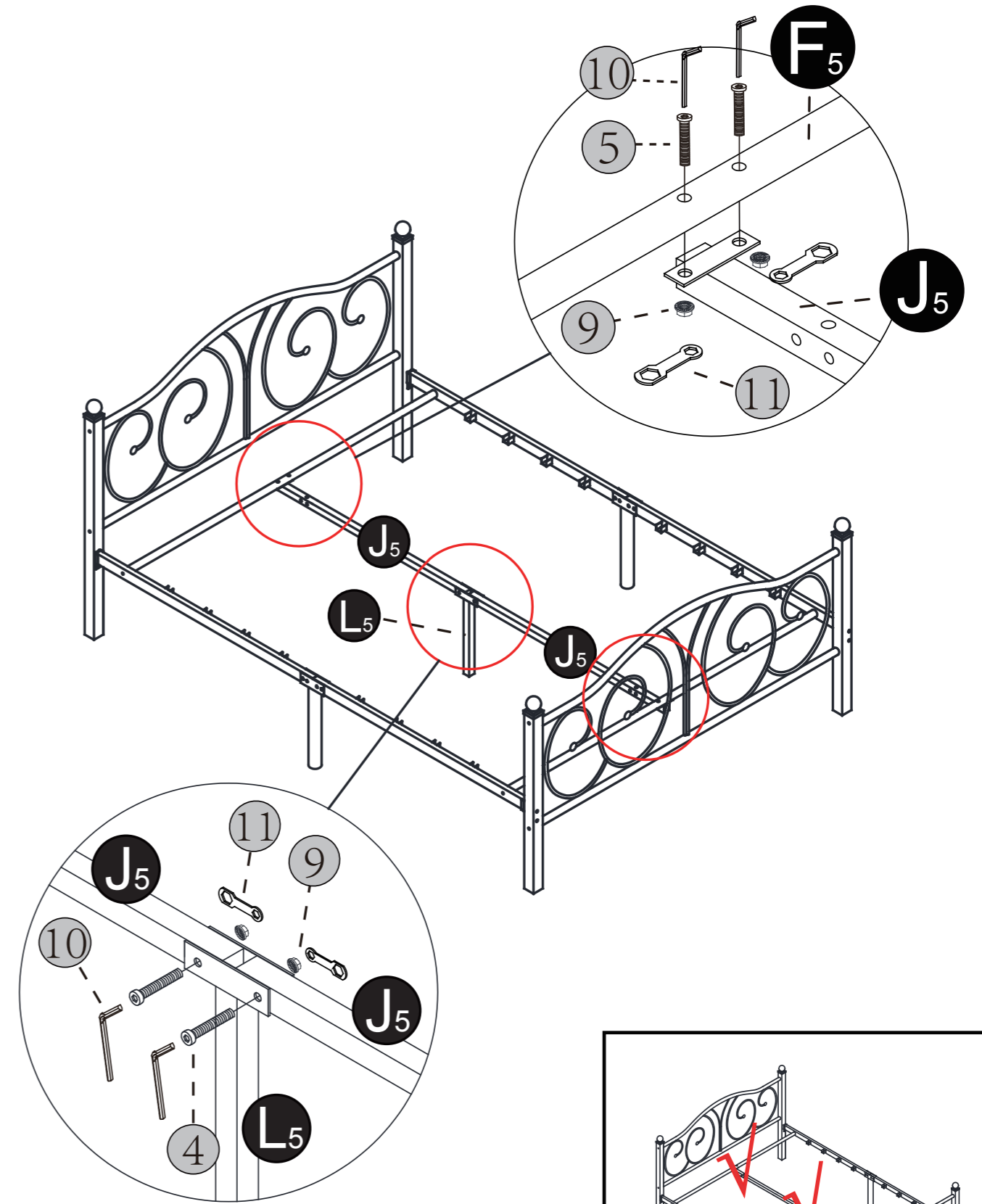

# Step 6

4 x4

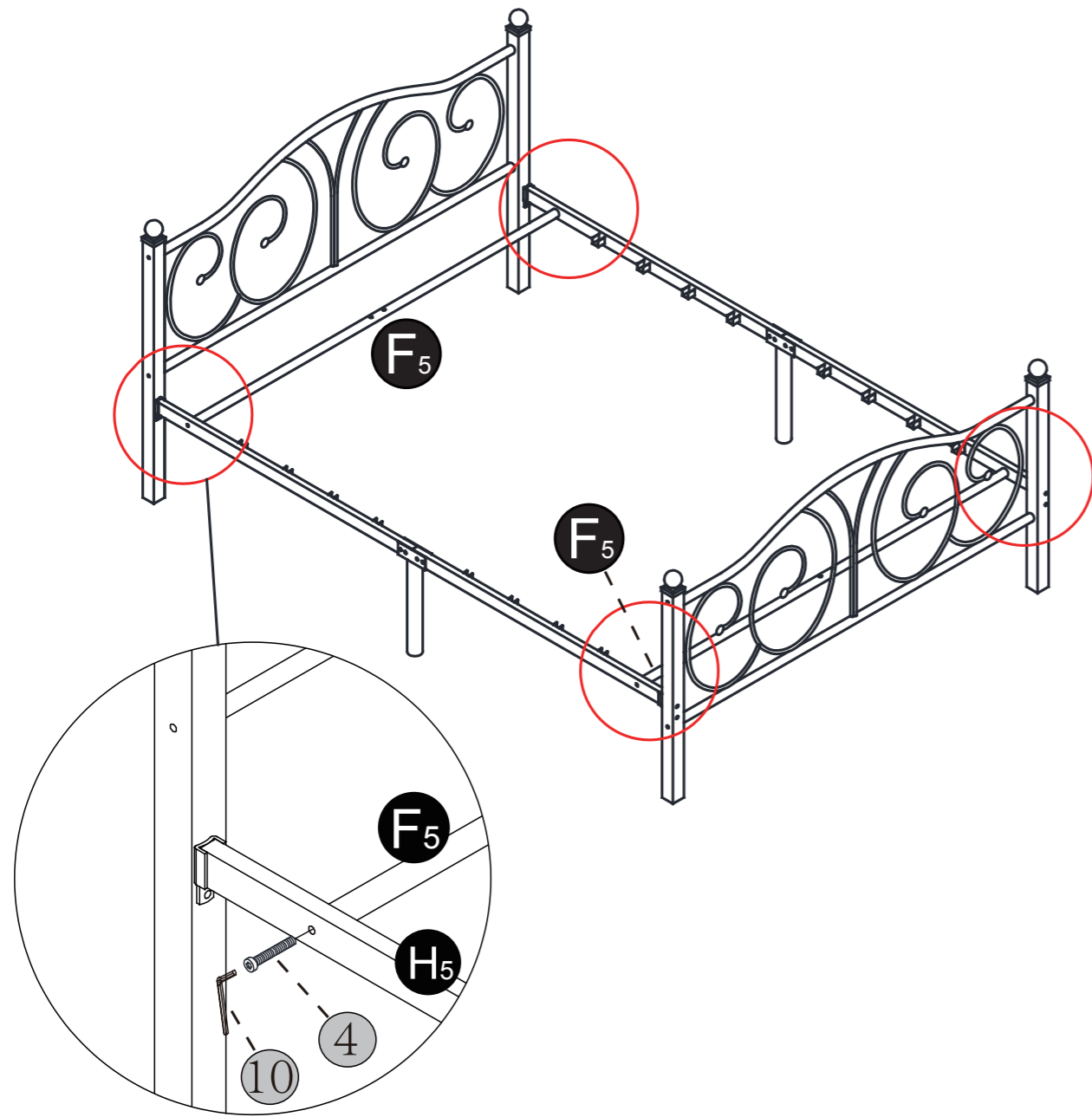

- Note:  
Do not fully tighten screw 4 yet
- ★ Hinweis:  
Ziehen Sie Schraube 4 noch nicht ganz fest.
- ▲ Remarque :  
Ne pas encore serrer la vis 4 à fond.

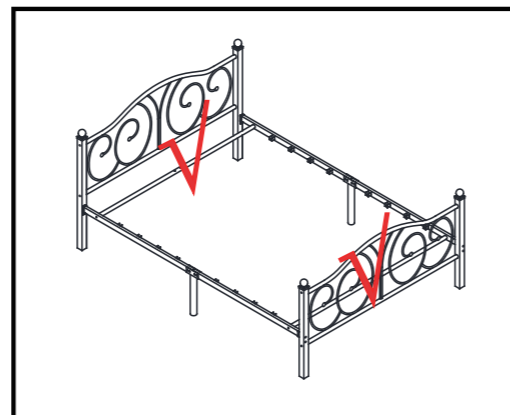

# Step 3

2 x4  
6 x4  
8 x4

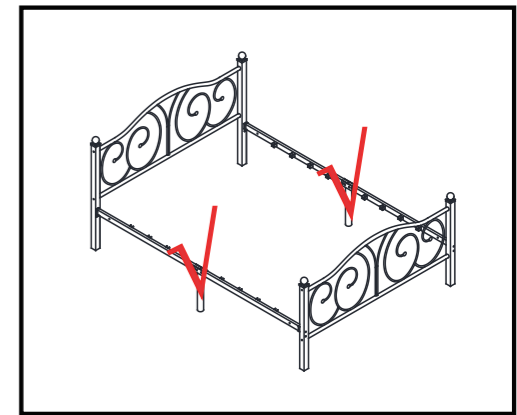
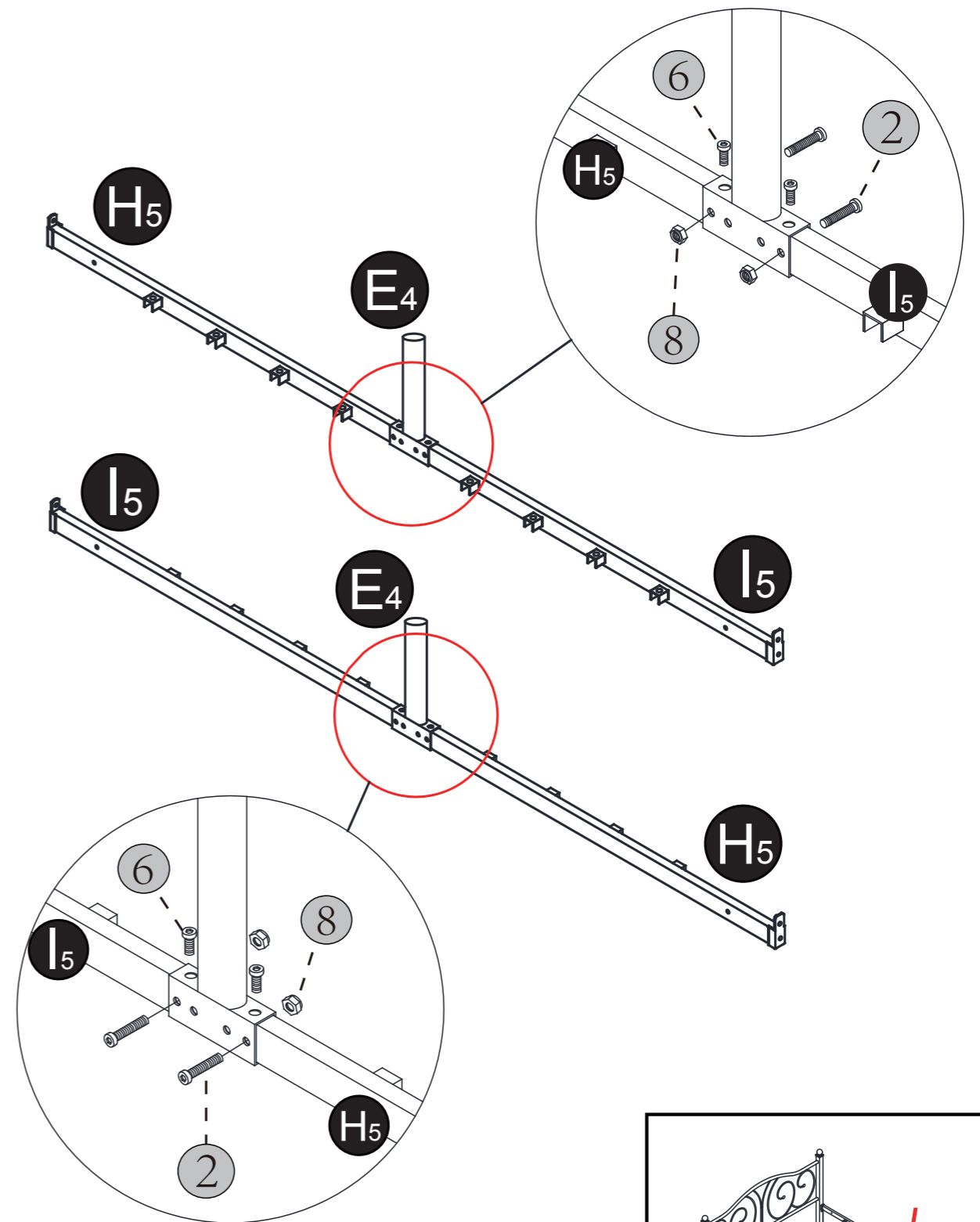

# Step 4

- 1 x4
- 7 x4
- 8 x2

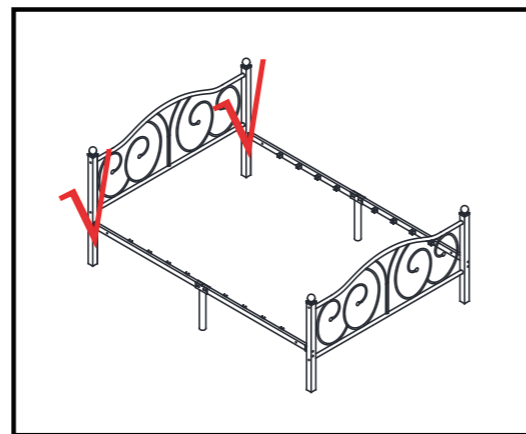
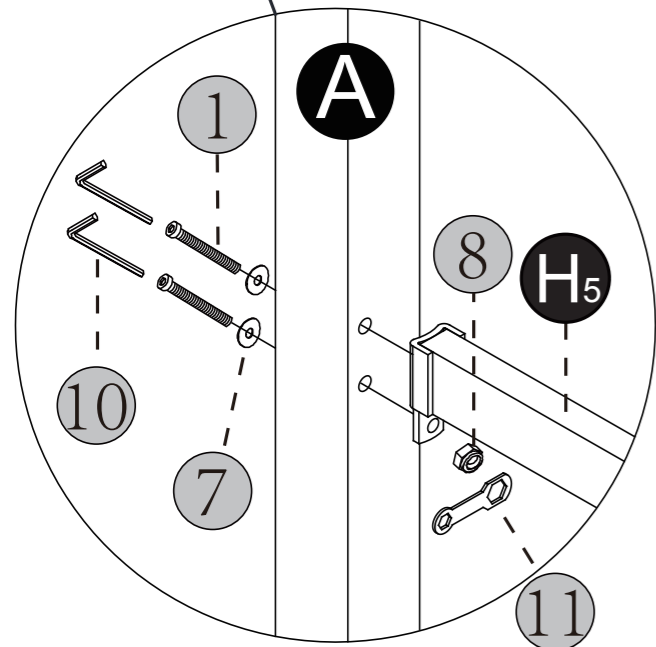
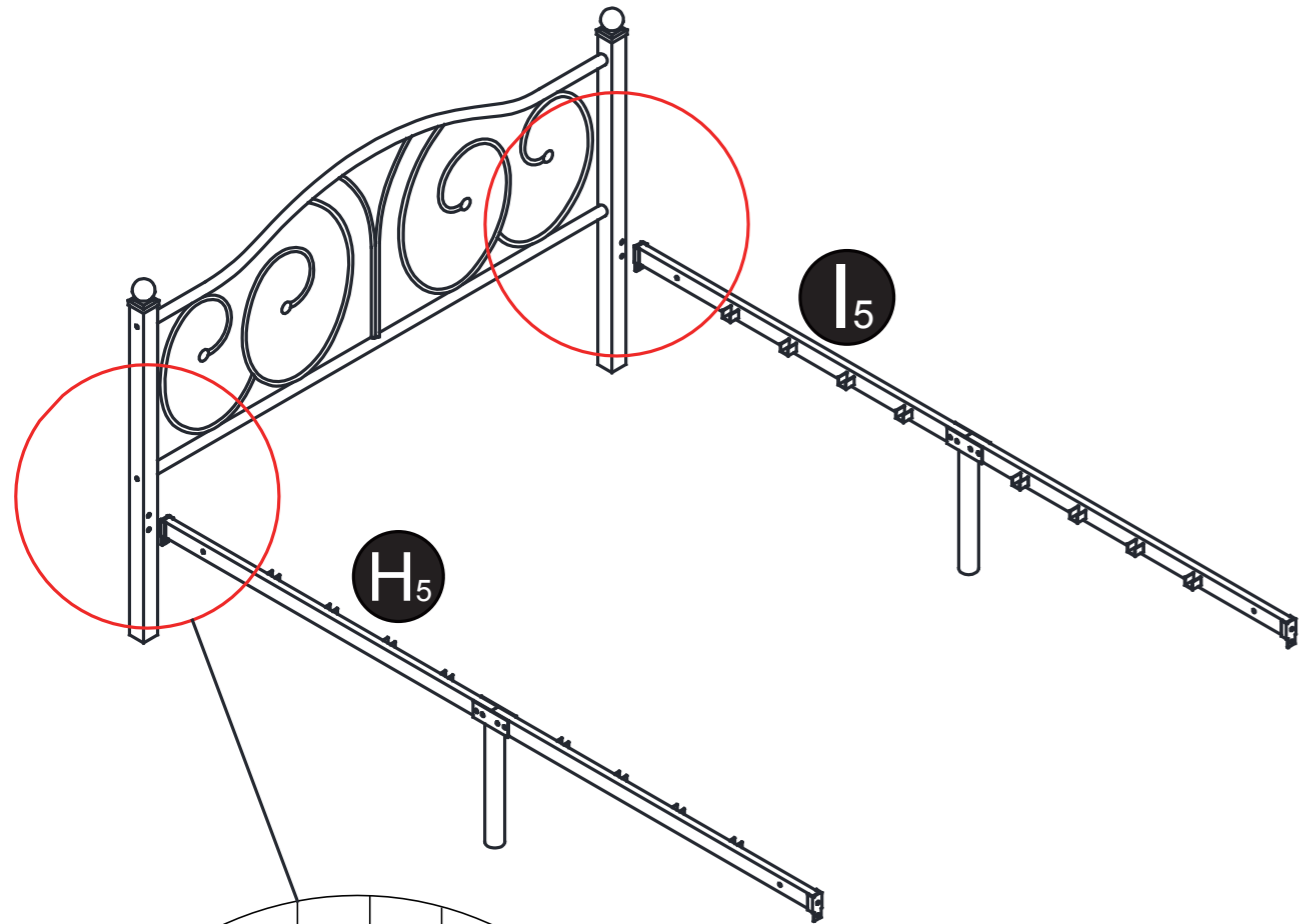

# Step 5

- 1 x4
- 7 x4
- 8 x2

