

Assembling Instruction

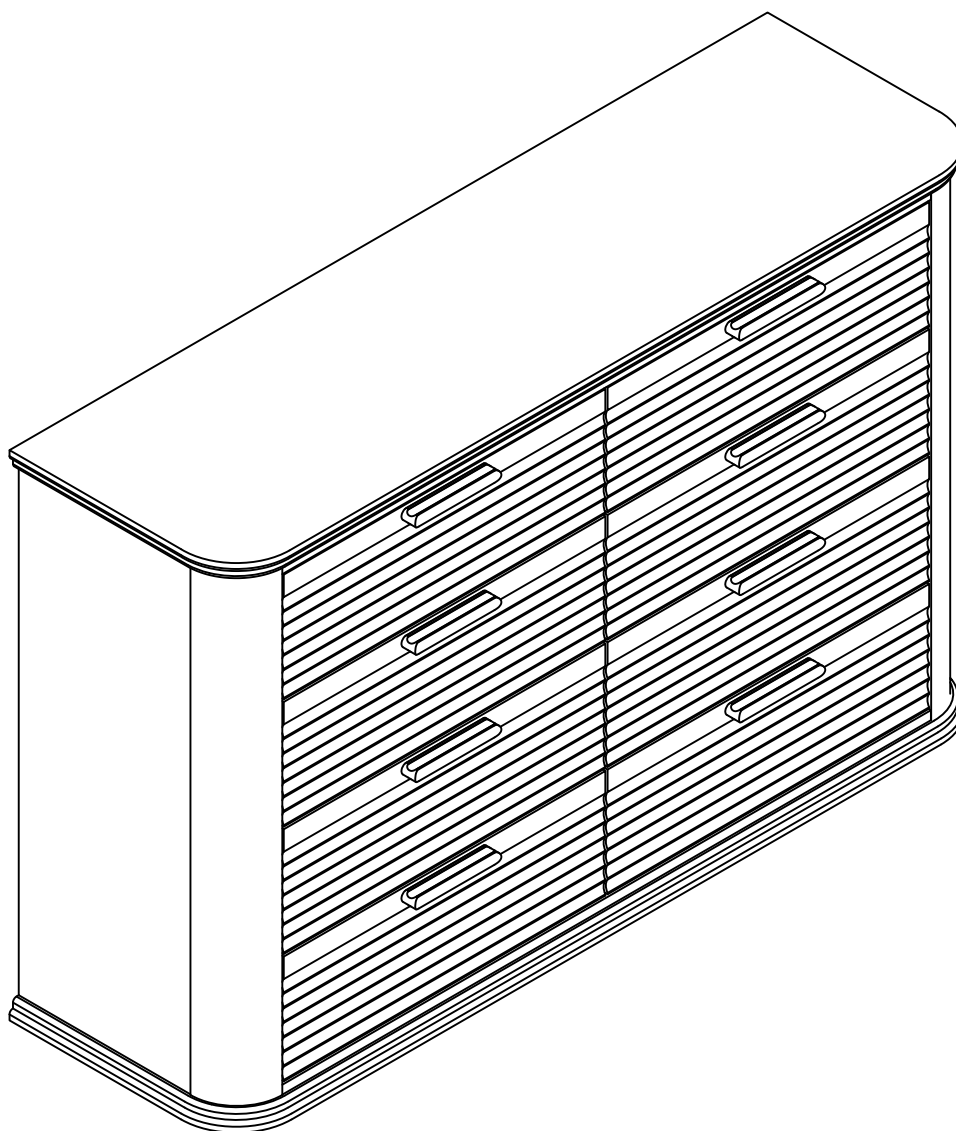

ATTENTION

If there is any missing, please kindly send us messages to let us know the name of missing part regarding to the first page of instructions.

We will send replacement to you asap. We are concerned about each customer's experience, if there is any loss or damage, please contact us at any time, we will provide effective solutions.



General Assembly Guidelines

- I. Ensure that all parts and hardware are available before beginning assembly.
- II. Follow each step carefully to ensure the proper assembly of this product.
- III. Two people are recommended for ease in the assembly of this product.
- IV. The three main types of hardware used to assemble this product are : wood dowels , screws and bolts.
- V. The provided glue is to secure wood dowels in place . When first inserting dowels , locate the appropriate hole for the dowel , place a small amount of glue in the hole and insert the dowel . Wipe away excess glue immediately.

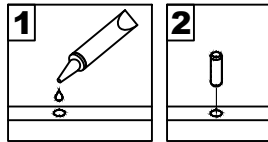

In future assembly steps when dowels are necessary to attach assembly parts together , place a small amount of glue on the end of the dowel before attaching parts together . Wipe away excess glue immediately.

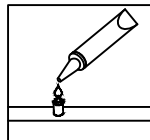

- VI. A Phillips head screwdriver is required for the assembly of this product .

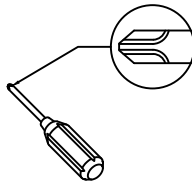



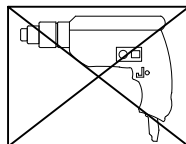



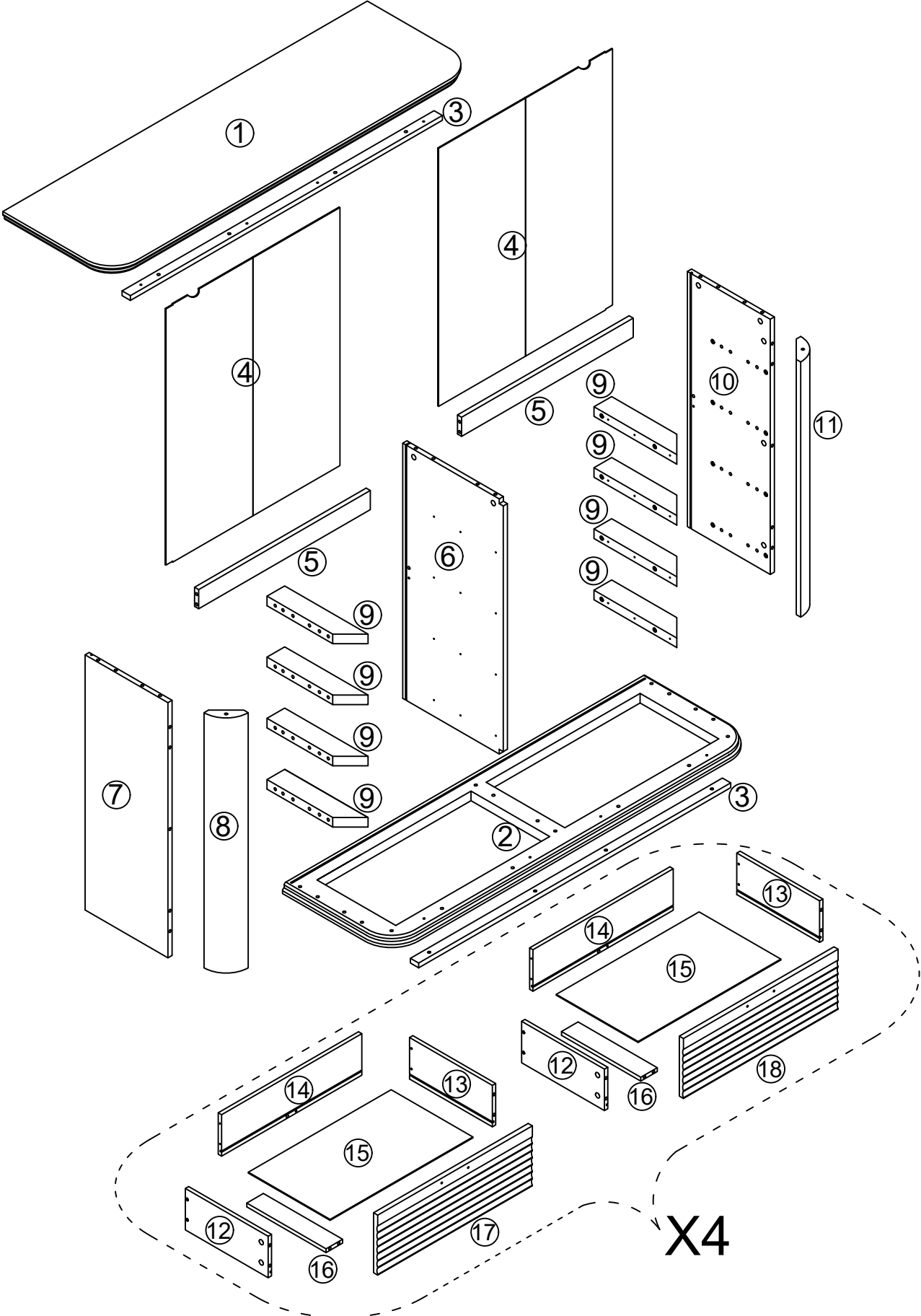



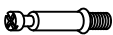





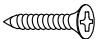

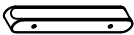

- VI. Power tools should not be used to assemble this product .



Parts List



Hardware List

A		Ø6x32mm	Cam bolt	58	pcs
B		Ø15x11mm	Cam lock	18	pcs
C		Ø6x50mm	Bolt	8	pcs
D			Hex Key	1	pc
E			Plastic wedge	20	pcs
F		Ø3x17mm	Screw	20	pcs
G		Ø4x25mm	Screw	8	pcs
H		M6x65mm	Bolt	16	pcs
I		Ø4x22mm	Bolt	16	pcs
J		160mm	Wooden handle	8	pcs
K		Ø4x32mm	Screw	40	pcs
L		Ø15x9mm	Cam lock	40	pcs
M		Ø30mm	Sticker	58	pcs
N		Ø8x30mm	Wooden dowel	76	pcs
O		Ø3x12mm	Screw	96	pcs
P		12"	Drawer slides	8	sets
Q		Ø30*3mm	Base pad	6	pcs
R		Ø4x40mm	Screw	2	pcs
S		Ø4x14MM	Screw	2	pcs
T		73x15x25mm	Corner plate	2	pcs
U		Ø6x40MM	House lizard	2	pcs
V			Glue tube	2	pcs

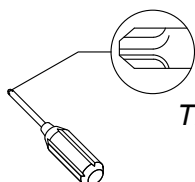

Philips head screwdriver required for assembly
(not included)

*The hardware quantities listed above are required for proper assembly.
Some extra hardware may also have been included.*

CAM LOCK/BOLT FASTENING INTRODUCTION

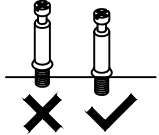
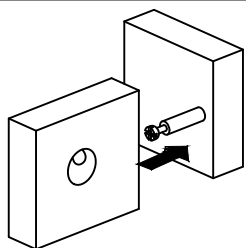
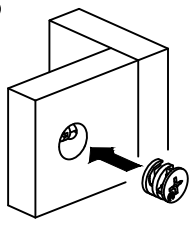
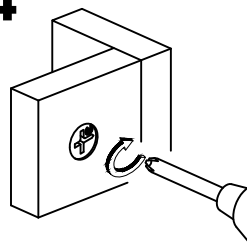

(You will use it during assembly)

<p>1</p> 	<p>2</p> 	<p>3</p> 	<p>4</p> 
<p>1.Screw cam bolt into the threaded anchor gently. (Attention:don't screw cam bolt too deep or too shallow.)</p>	<p>2.Please connect the 2 boards you want connect by inserting cam bolt.</p>	<p>3.Insert the cam lock into the round hole of the board. (Attention:point the arrow on the top of the cam lock to the outer edge.)</p>	<p>4.Turn the cam lock clockwise until it is firmly tightened.</p>

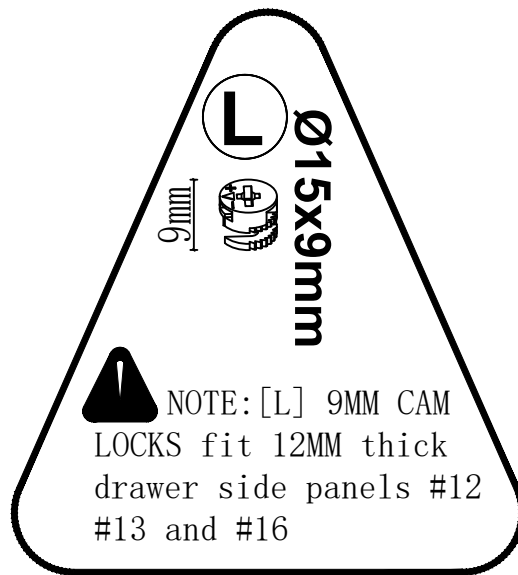
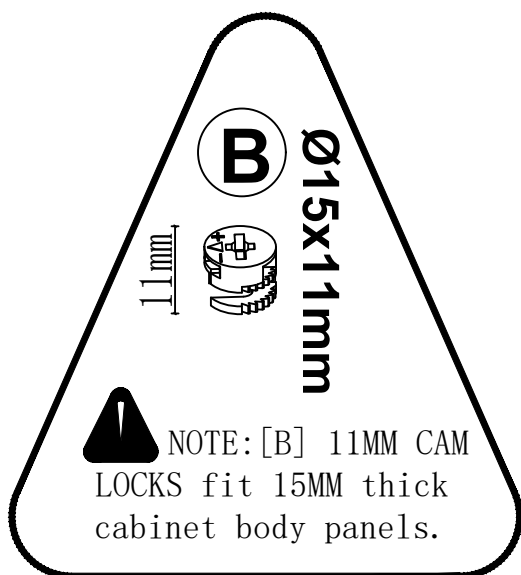
Please use [B] and [L] CAM LOCKS as shown in the illustrations.



Step 1

N	K
	
X8	X40

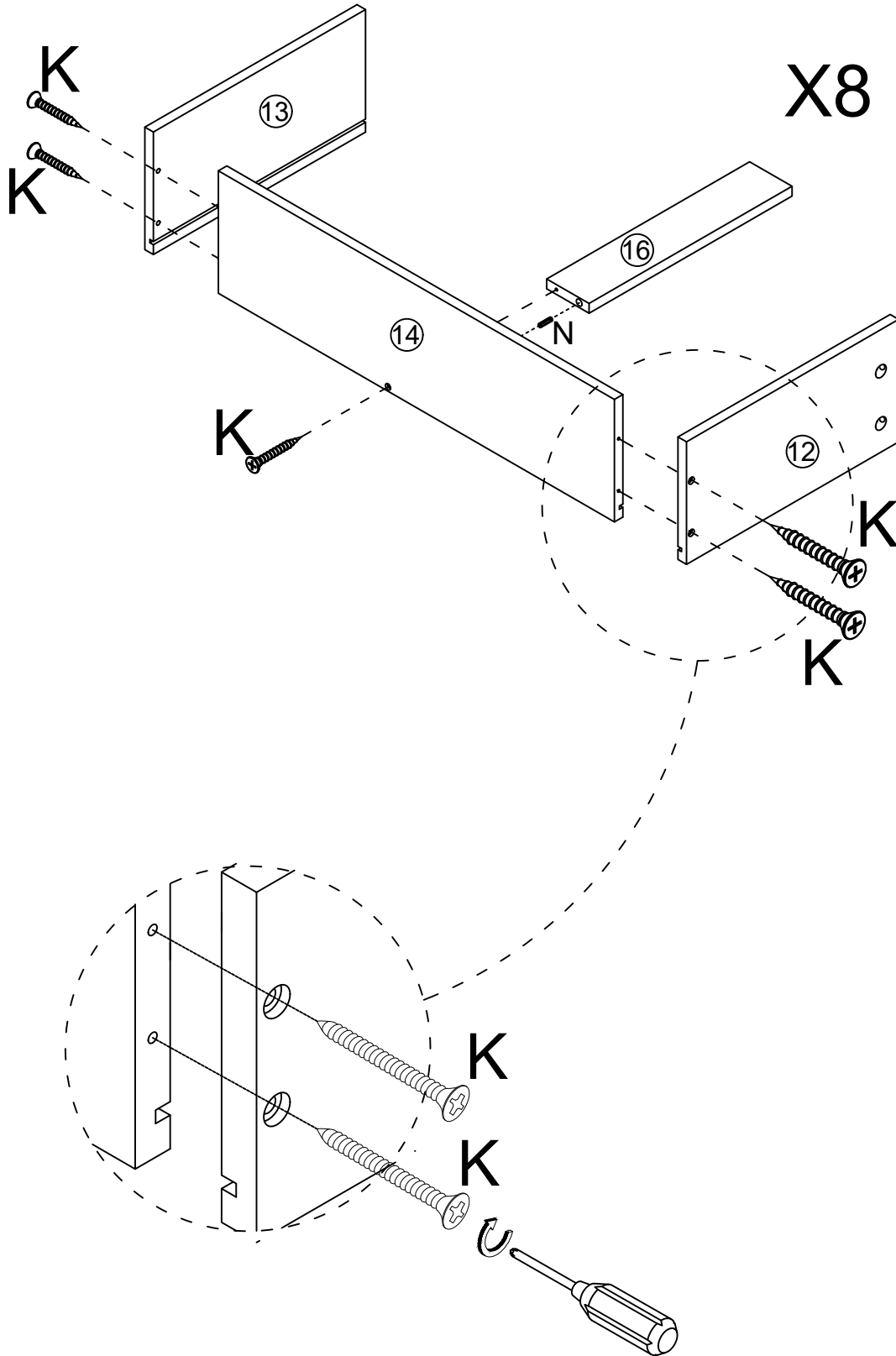

Step 2

A

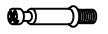

X40

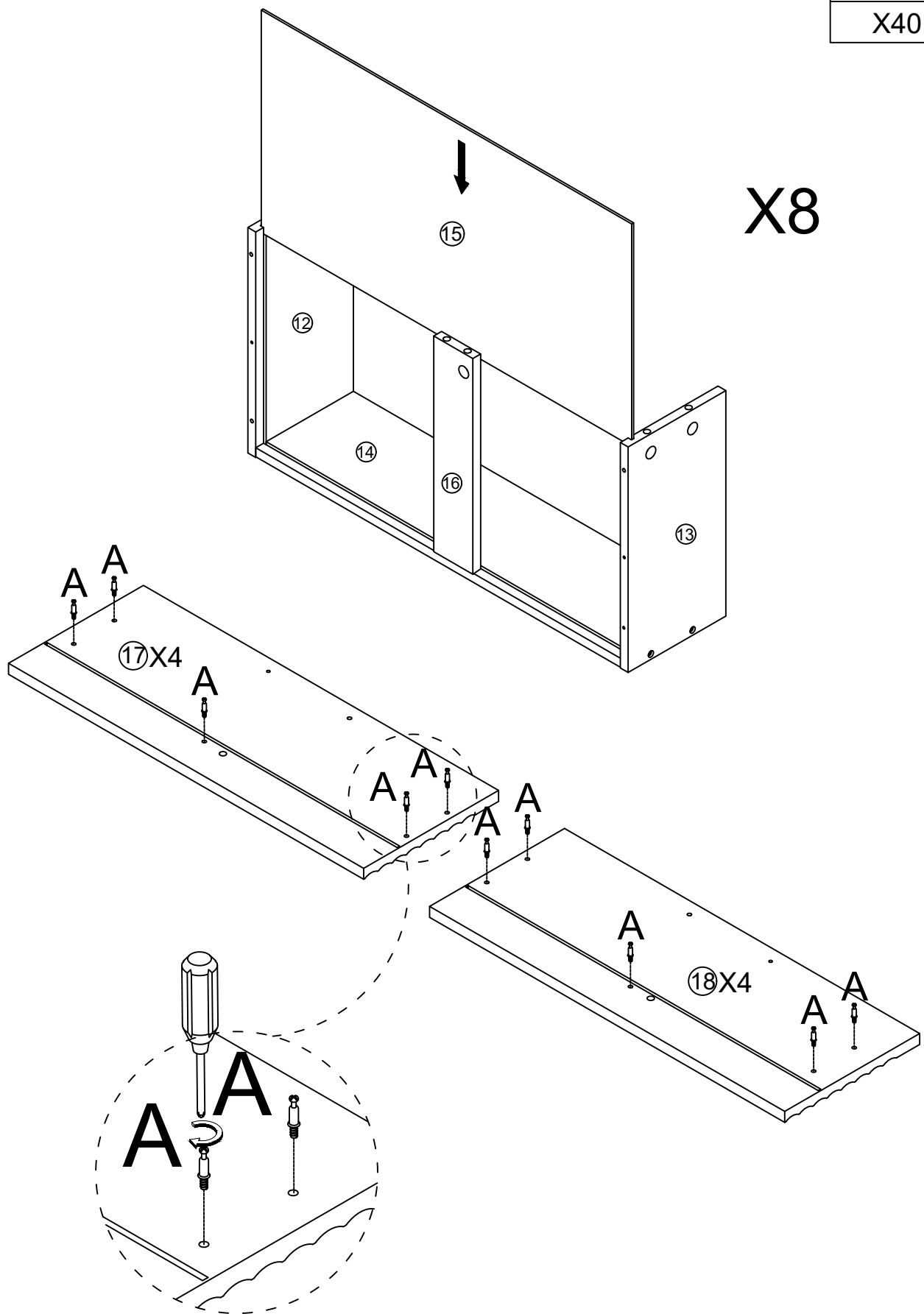

Step 3

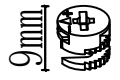

N	L
	
X8	X40

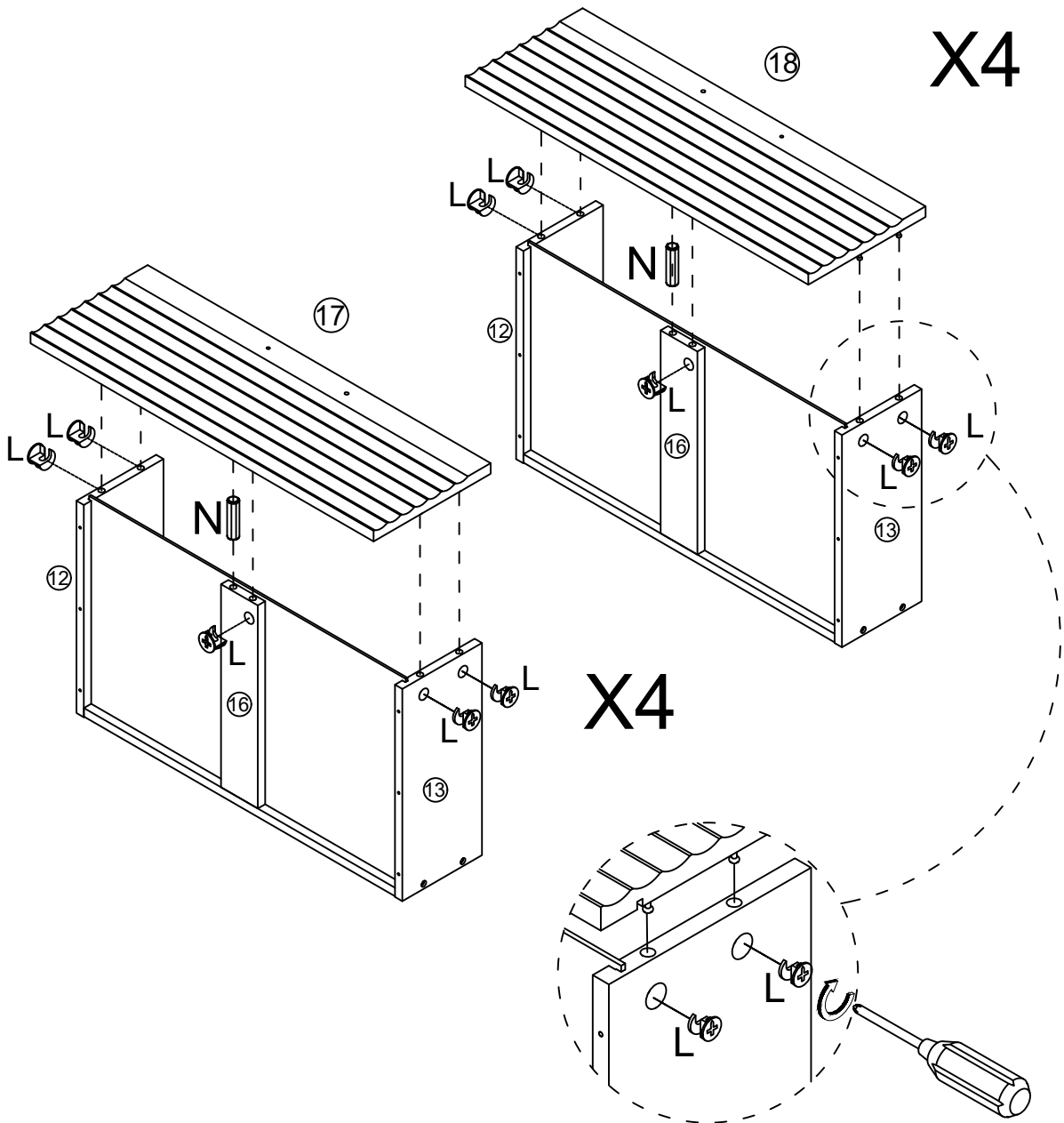

NOTE: Be sure to use [L] 9MM CAM LOCKS for the panels #13 and #16 and #12.

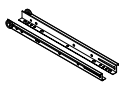

Step 4

P	O
	
X8	X48



NOTE:

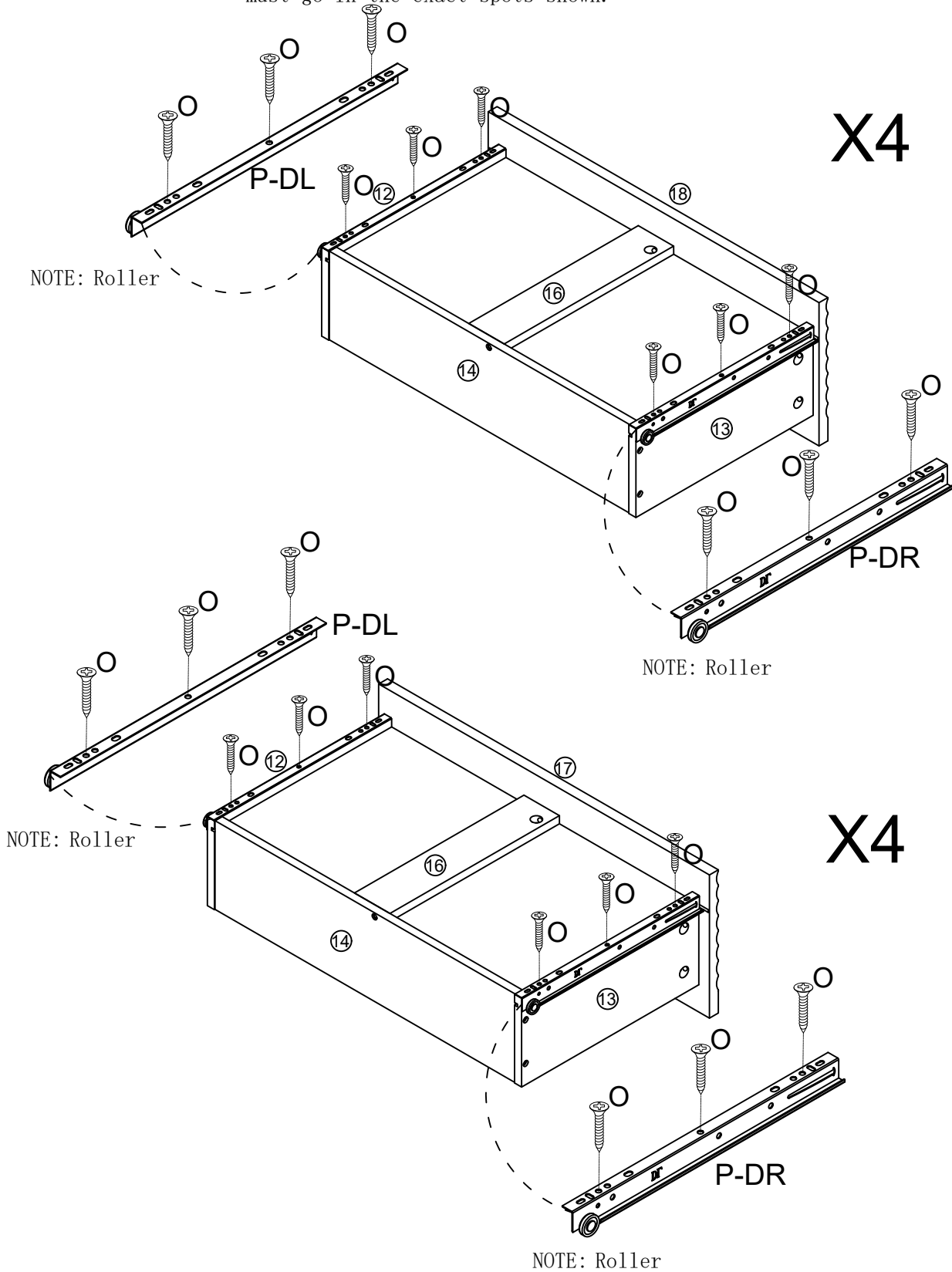

Refer to the images to identify P-DL (left) and P-DR (right). Attach P-DL to #12 panel and P-DR to #13 panel. [O] screws must go in the exact spots shown.

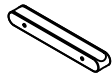

Step 5

J	I
	
X8	X16

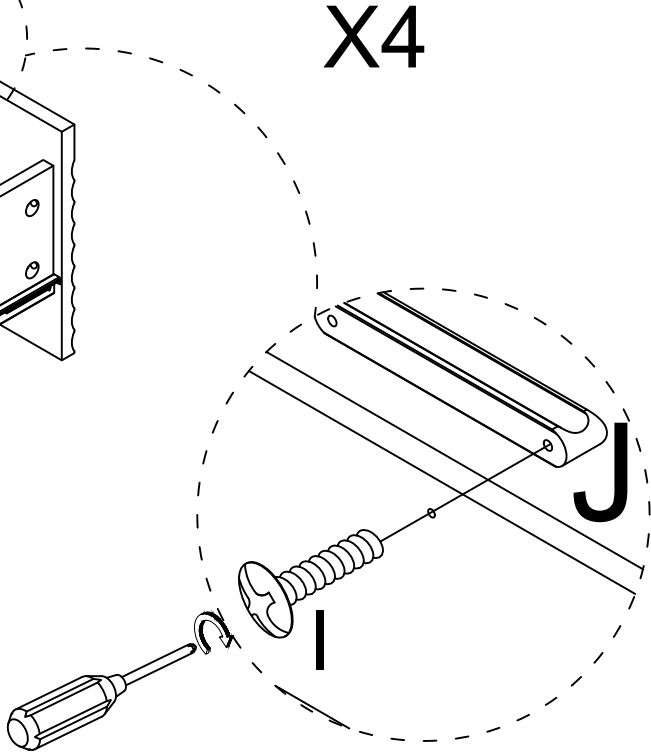
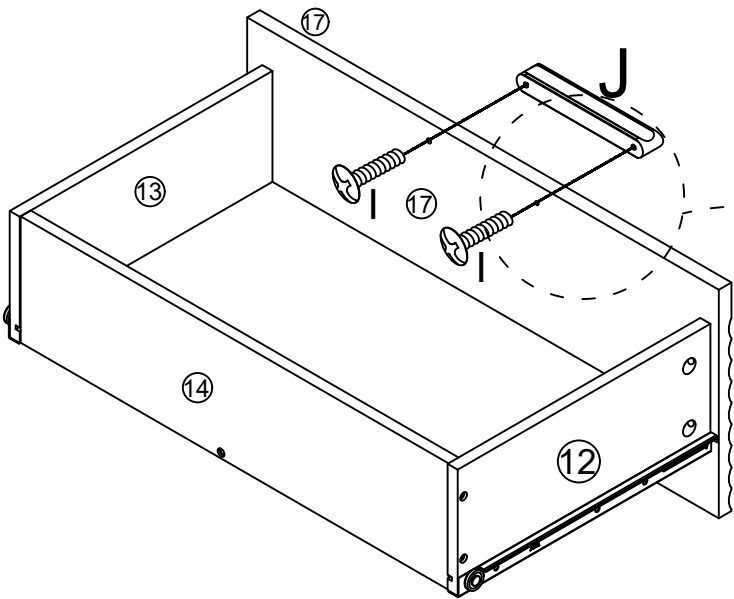
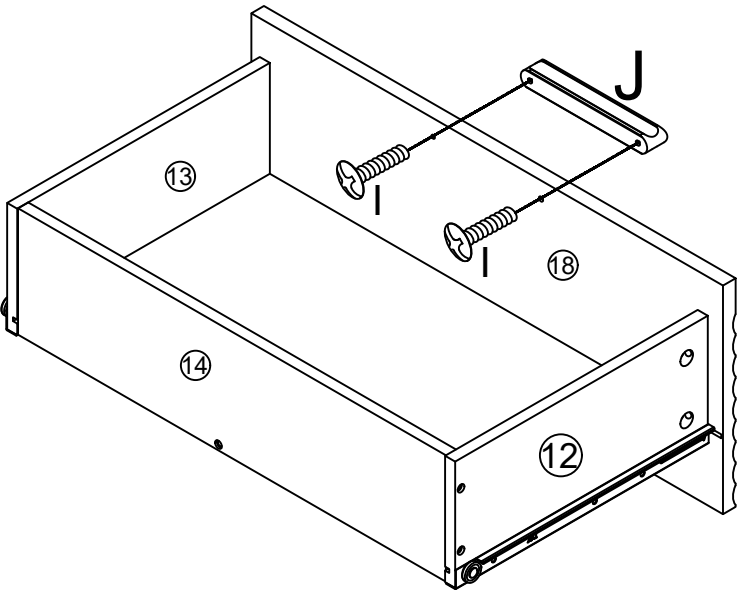

Step 6

M
O
X40

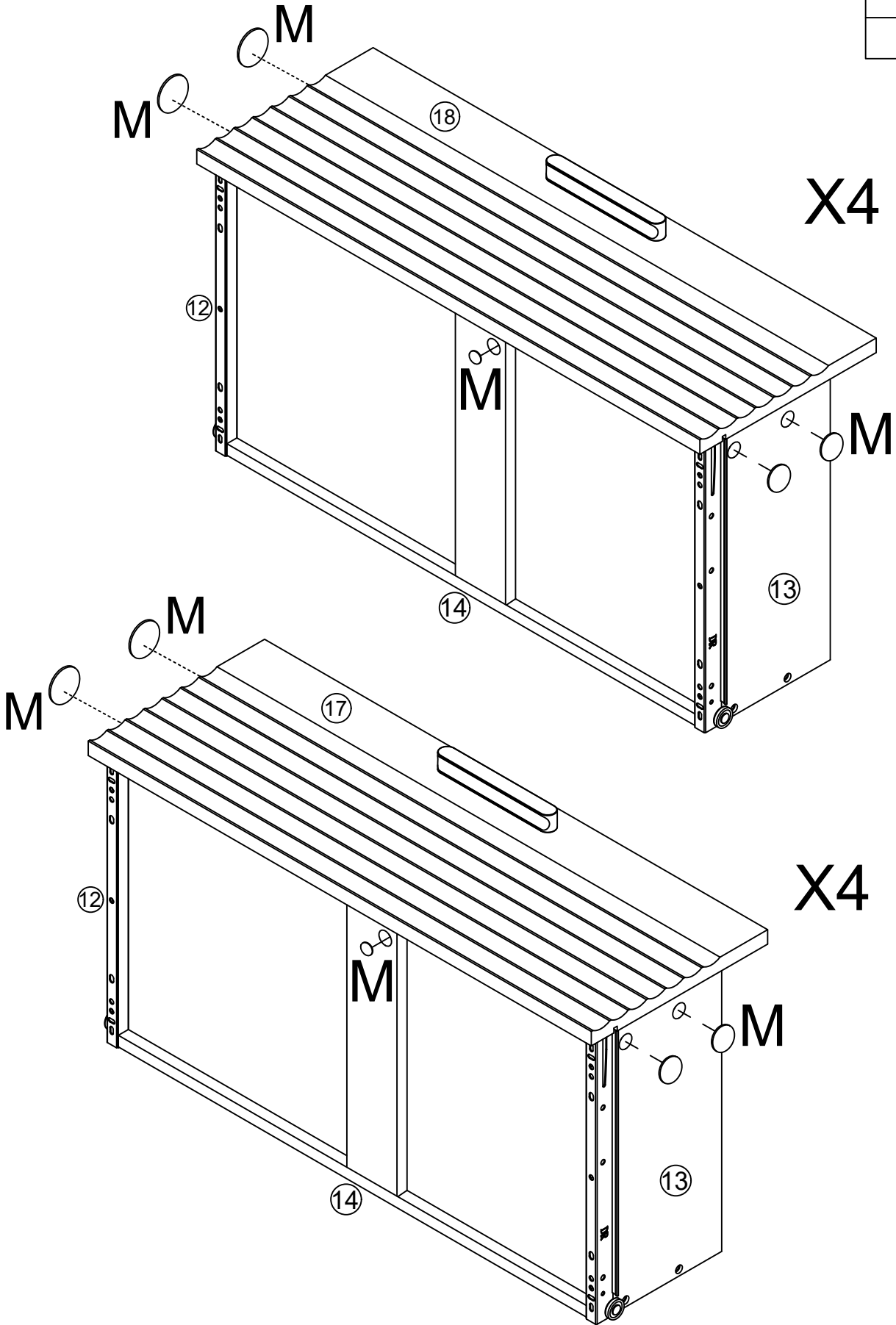

Step 7

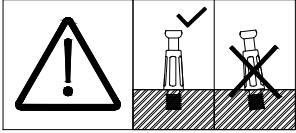

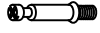

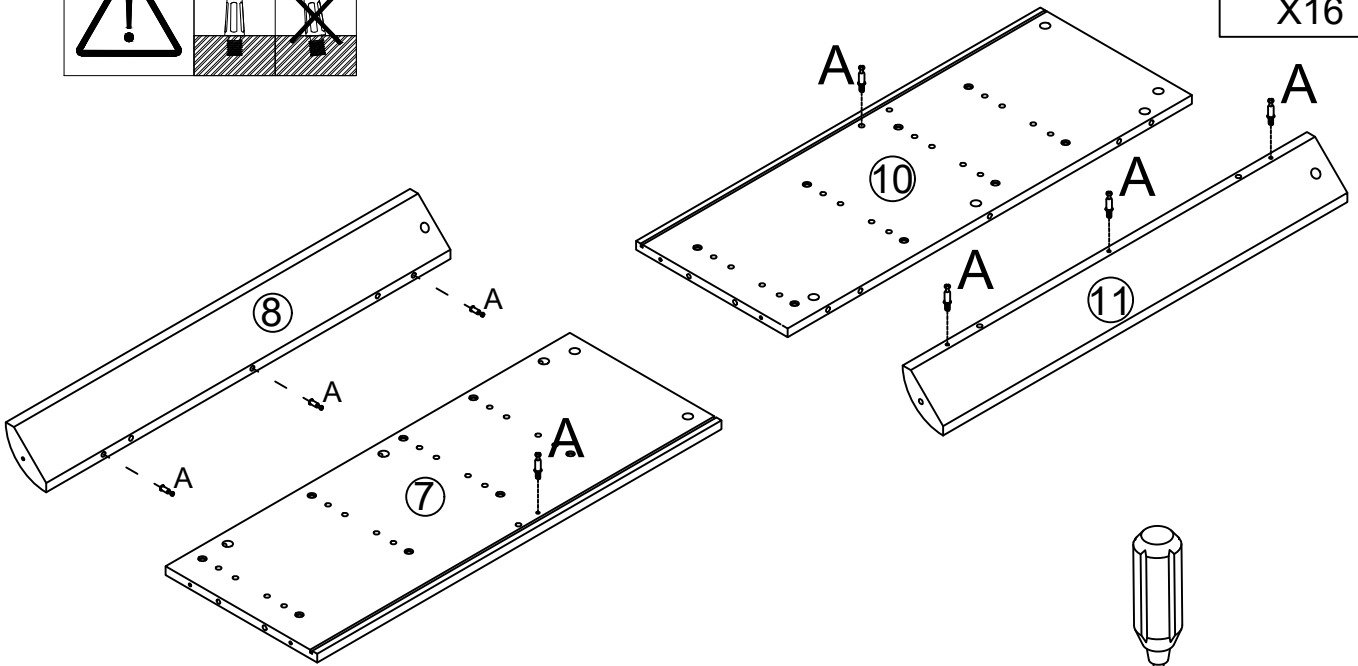
A

X16

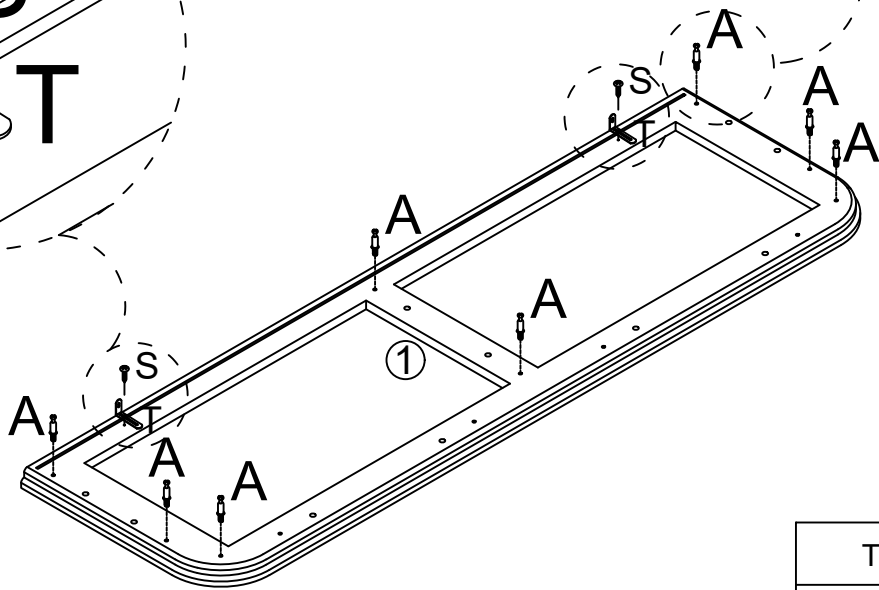
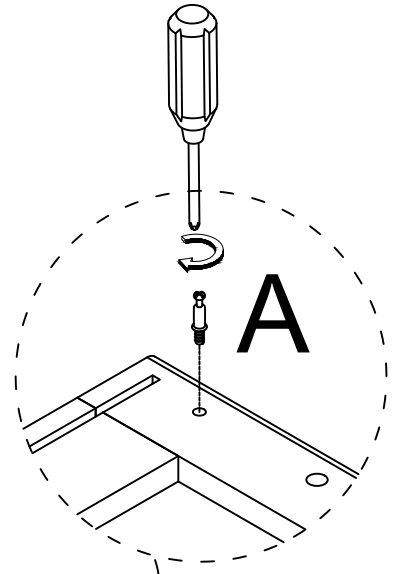
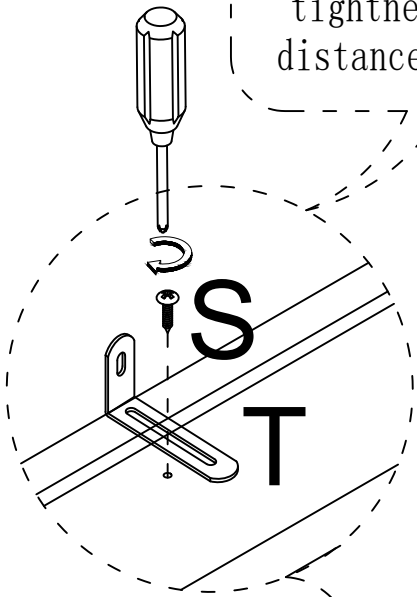



NOTE: Secure T with S to 95% tightness, you can adjust the distance when locking the wall.





T	S
	
X2	X2

Step 8

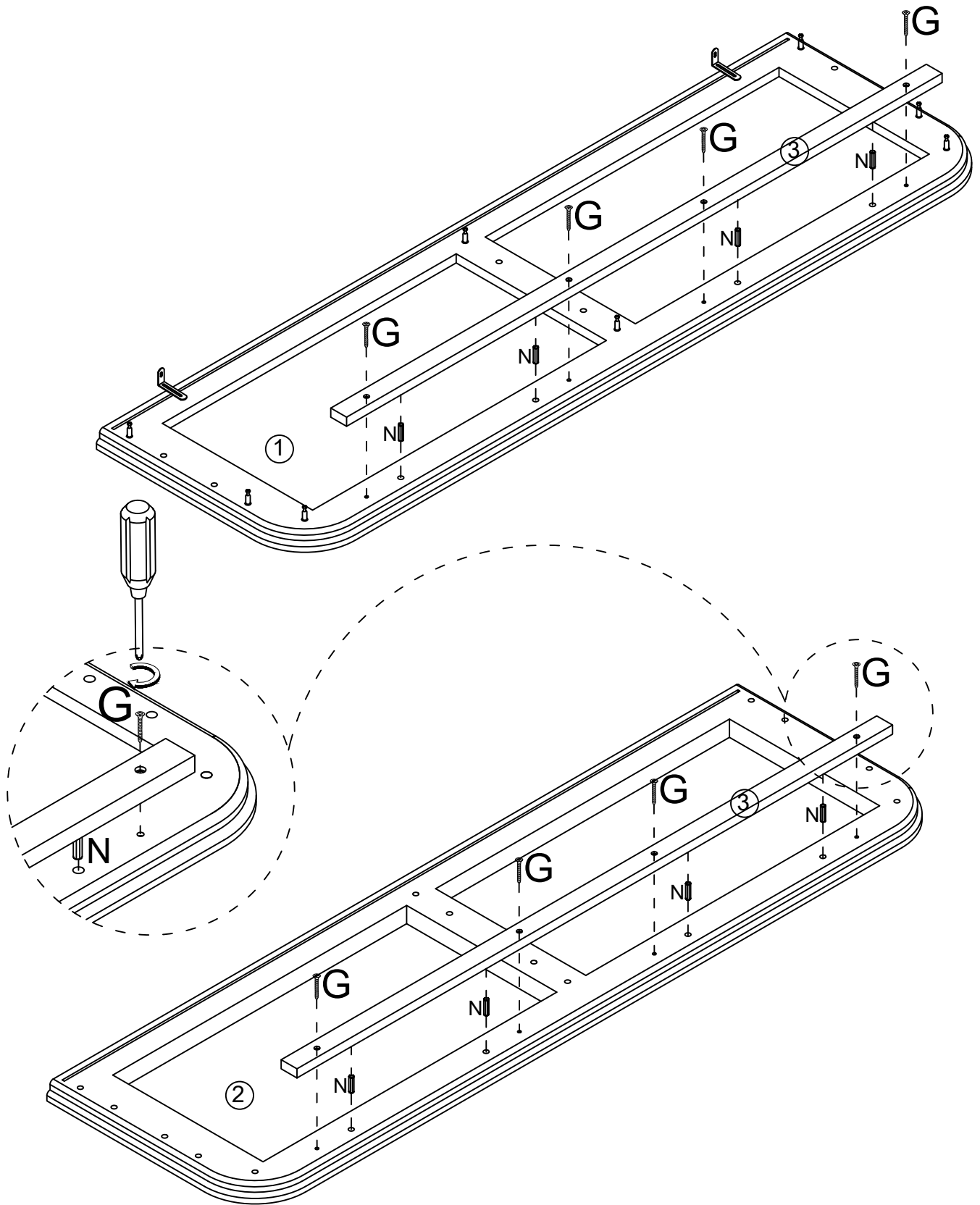
N	G
	
X8	X8



Step 9



N	B
	
X4	X6

NOTE: Use board of #7 to connect #8 leg,
use board of #10 to connect #11 leg.

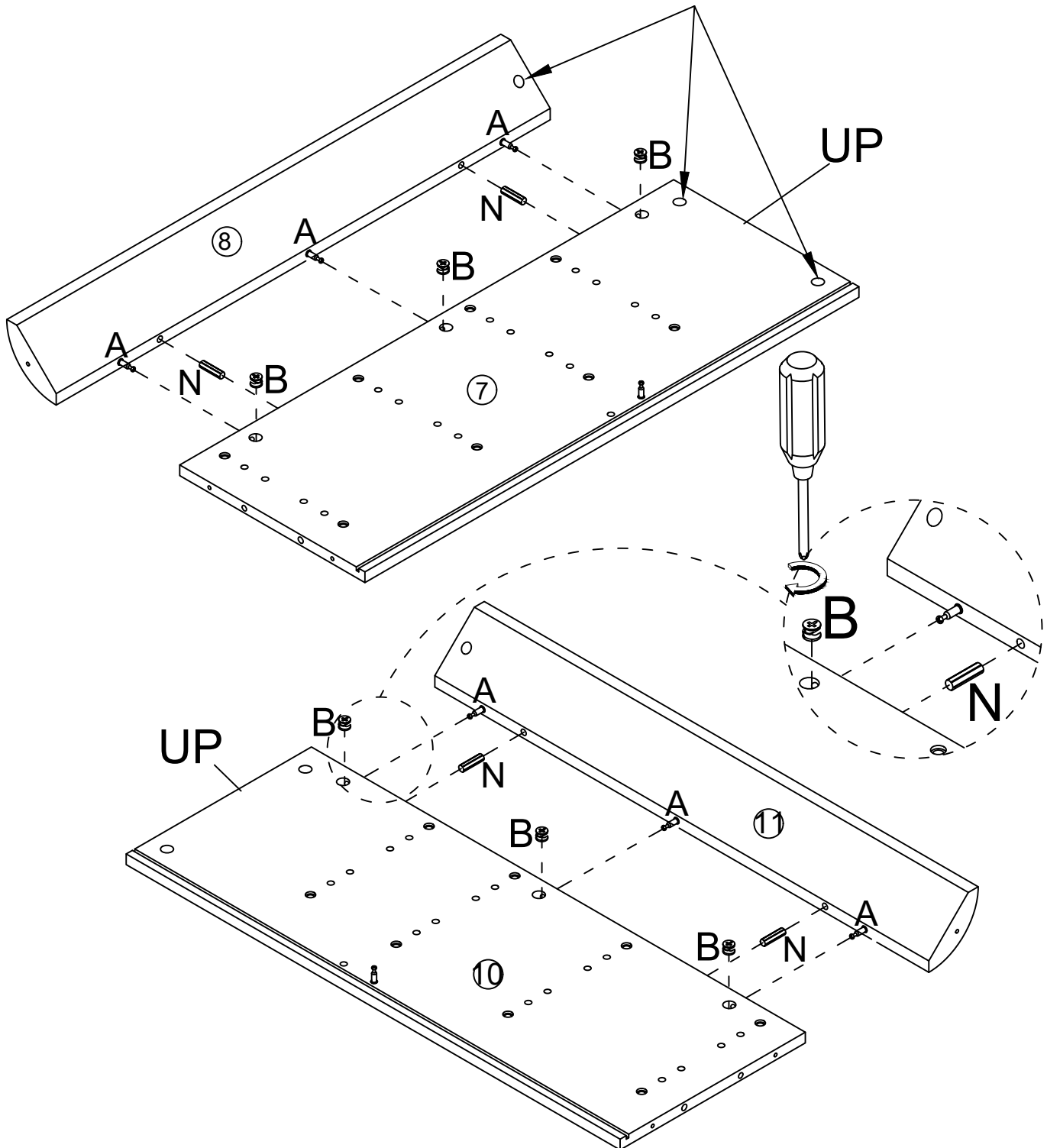
NOTE: Three cam lock holes should be
on the same side.



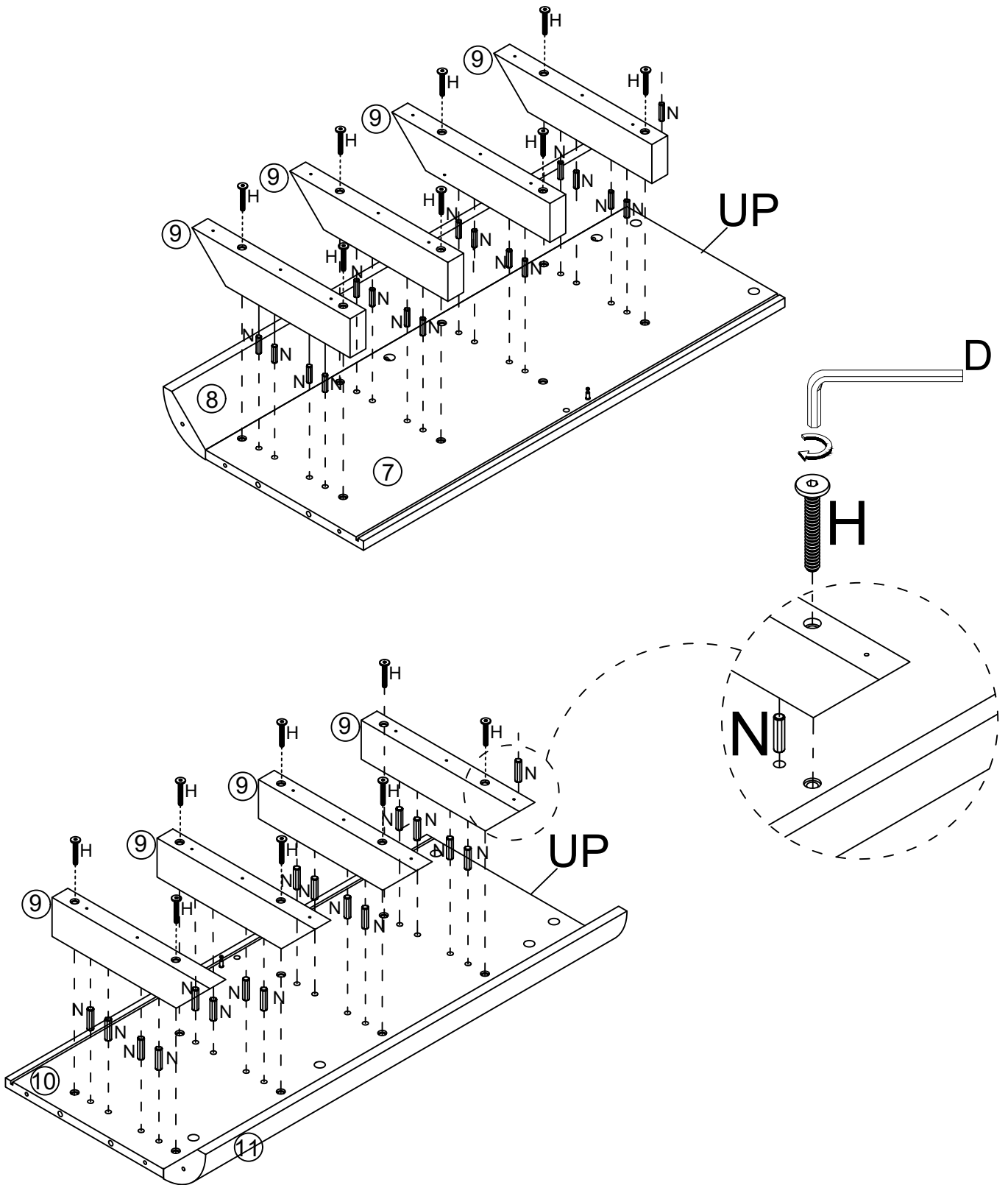

Step 10

N	H	D
		
X32	X16	X1

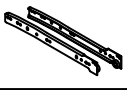

Step 11

P	O
	
X4	X24



NOTE:

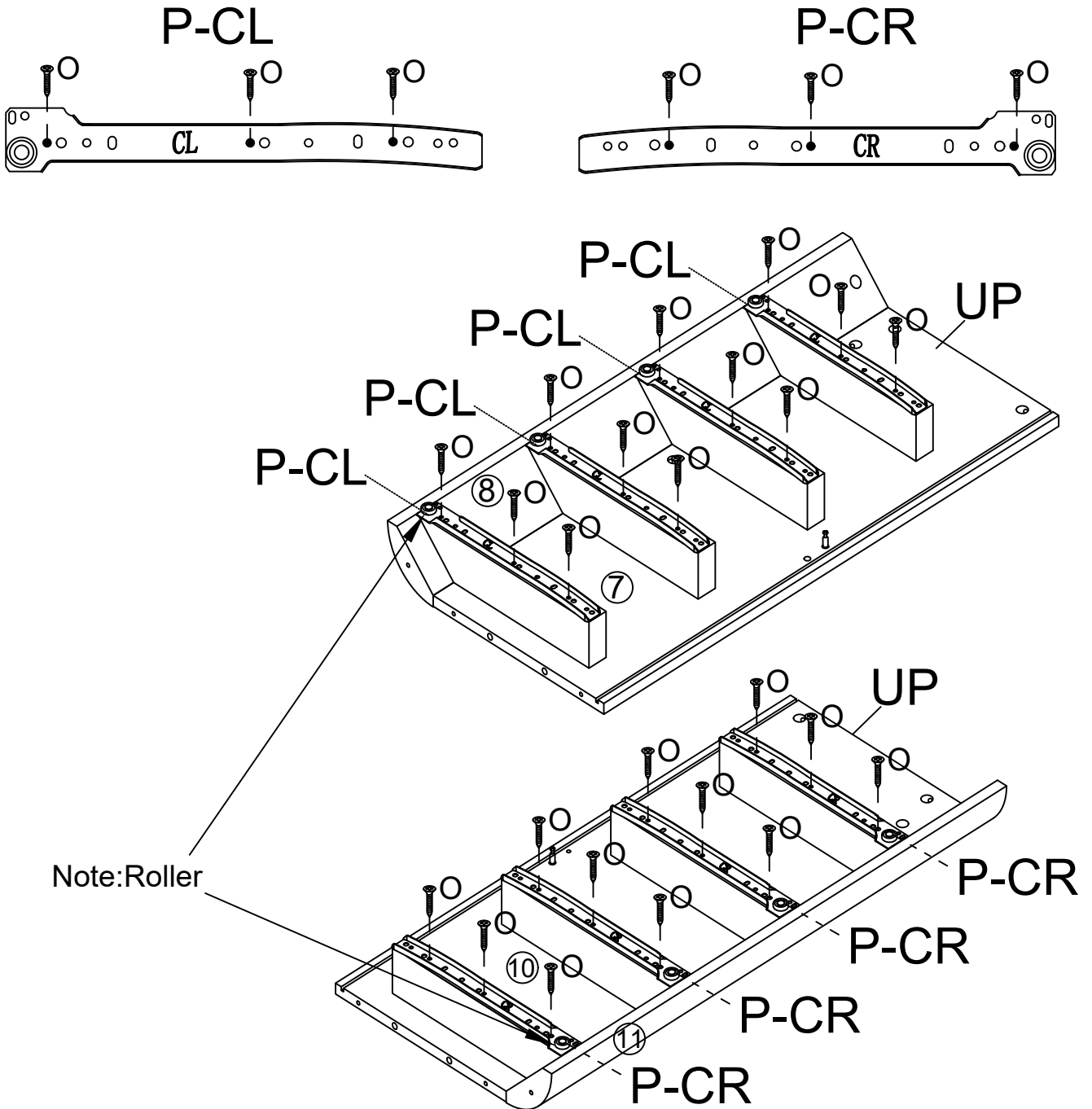

Refer to the images to identify P-CL (left) and P-CR (right). Attach P-CL to #7 panel and P-CR to #10 panel. [O] screws must go in the exact spots shown.



Step 12

P	O
	
X4	X24



NOTE:

Secure left slide (P(CL)) and right slide (P(CR)) to both sides of panel #6 with screw #0

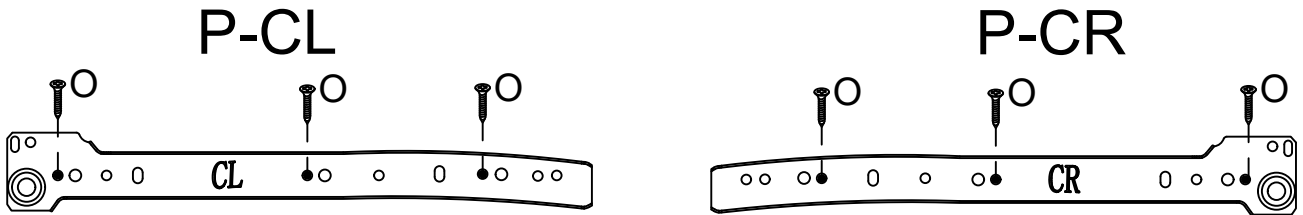

Note: This step involves only ONE board #6

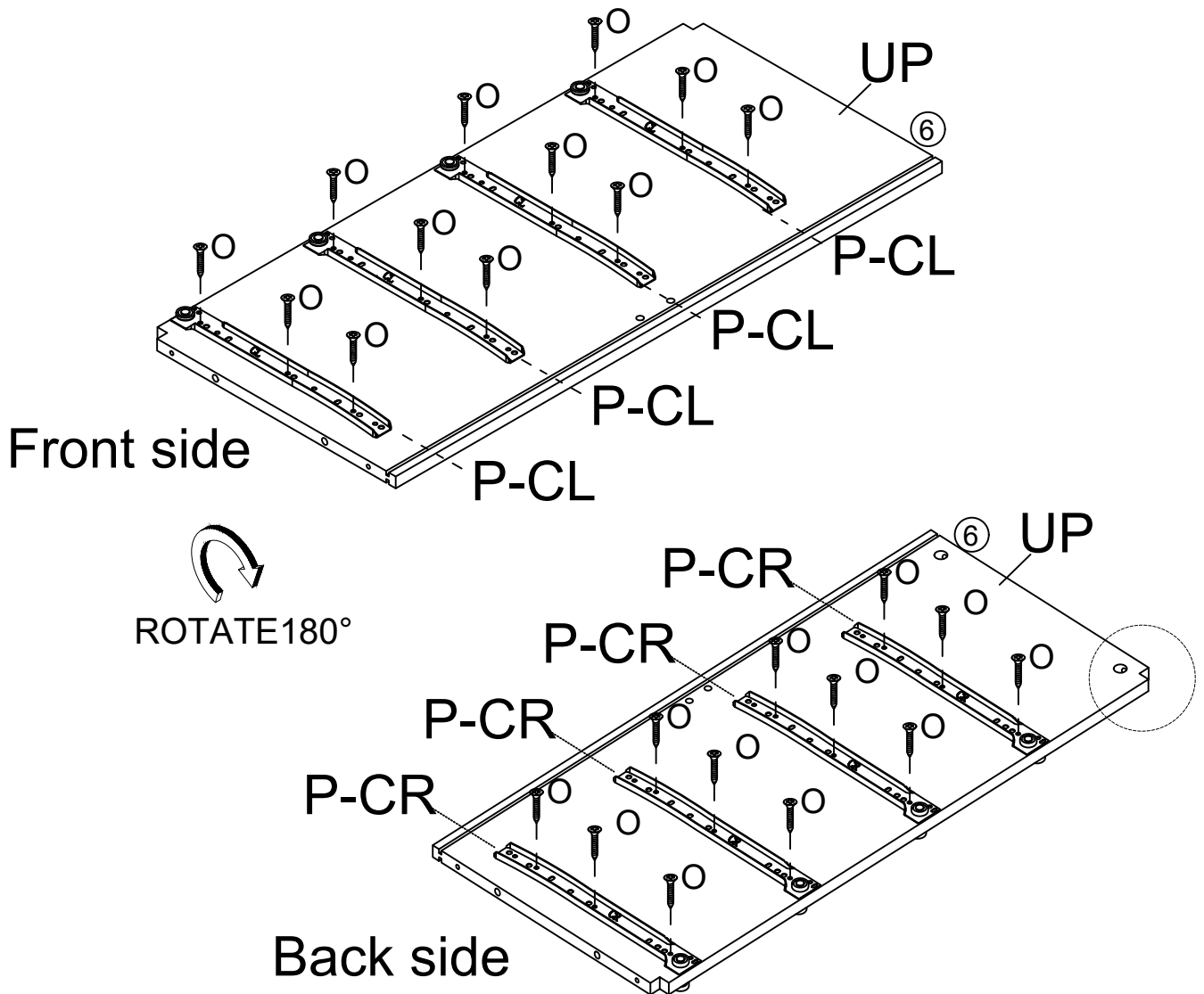

Step 13

A

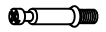

X2

Note: This step involves only ONE Board #6

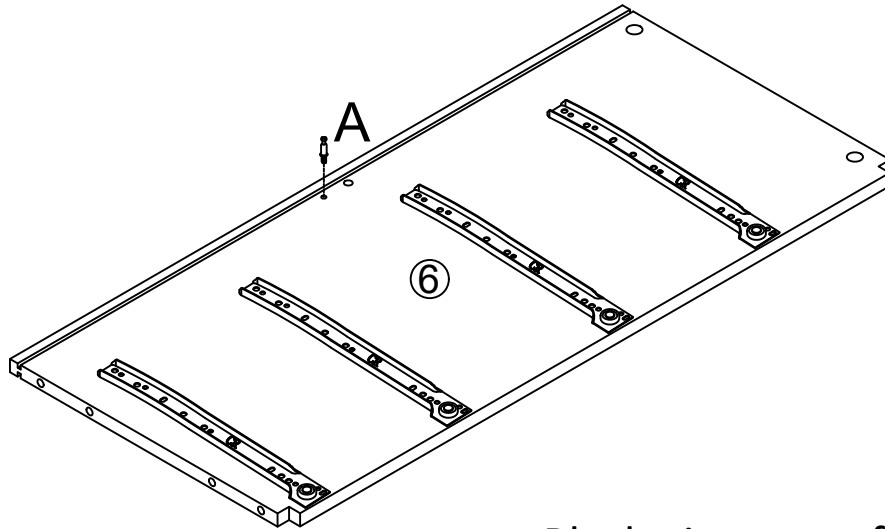

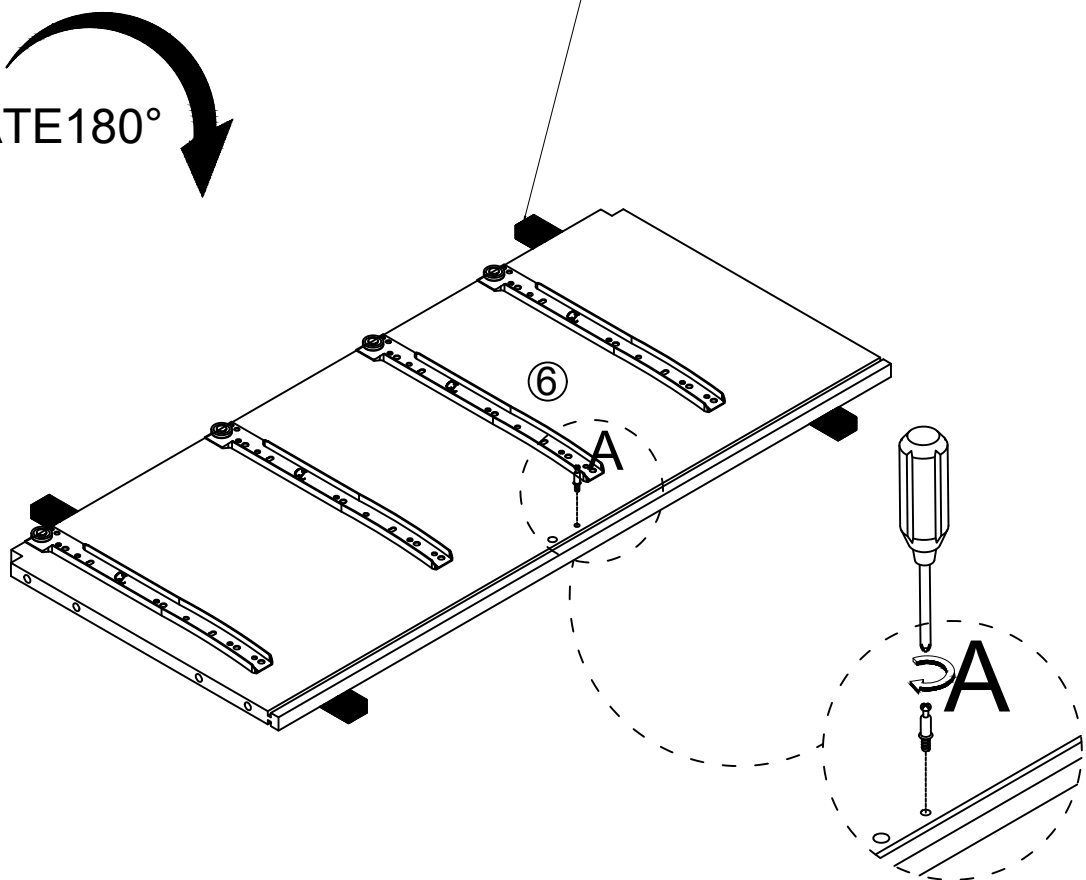

Black pieces are for raising demonstration only,
NOT included.

ROTATE 180°





Step 14

NOTE: It is recommended that 2 people assemble. One person needs to hold the boards to prevent them from falling over.

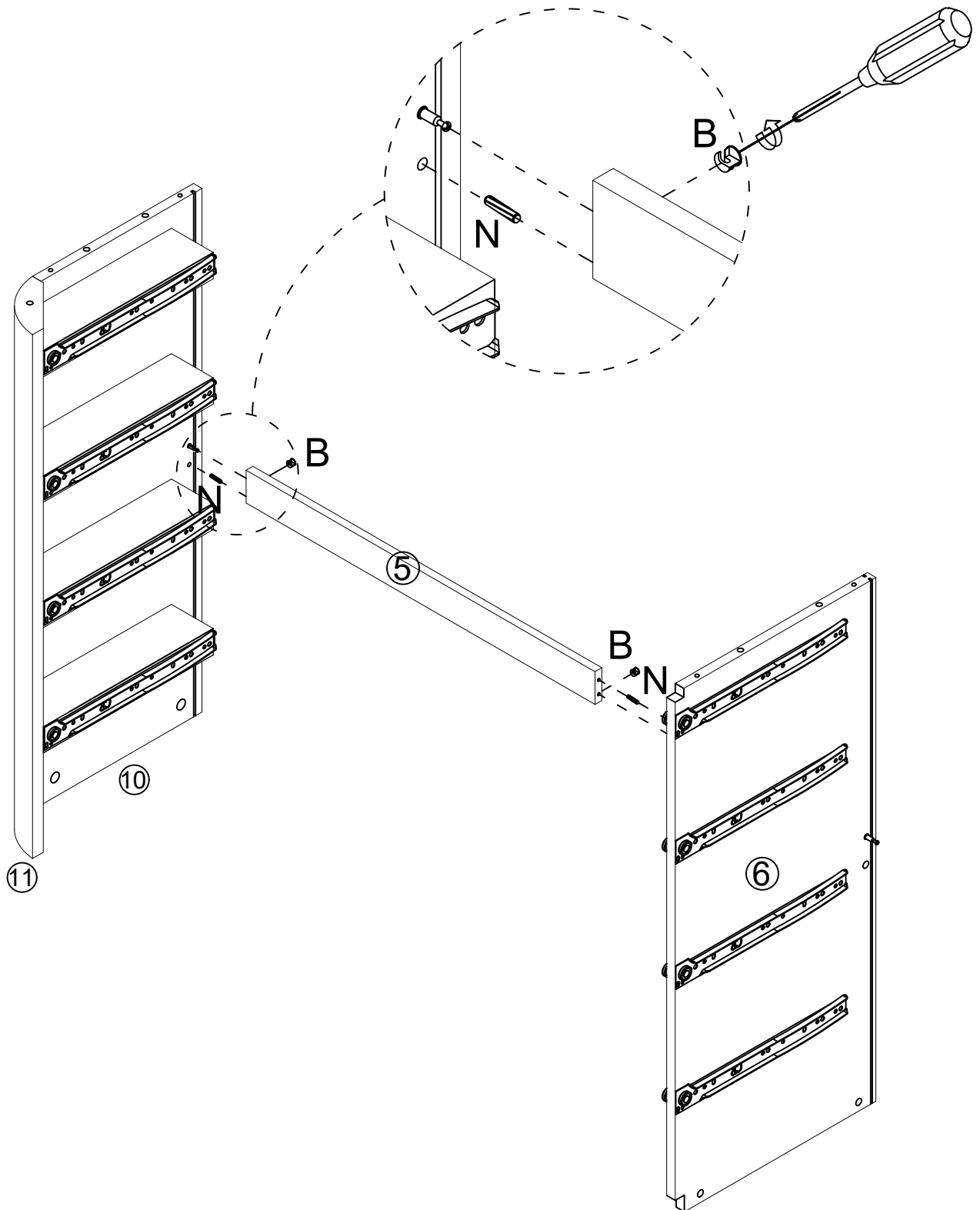
N	B
	
X2	X2





Step 15

N	B
	
X2	X2

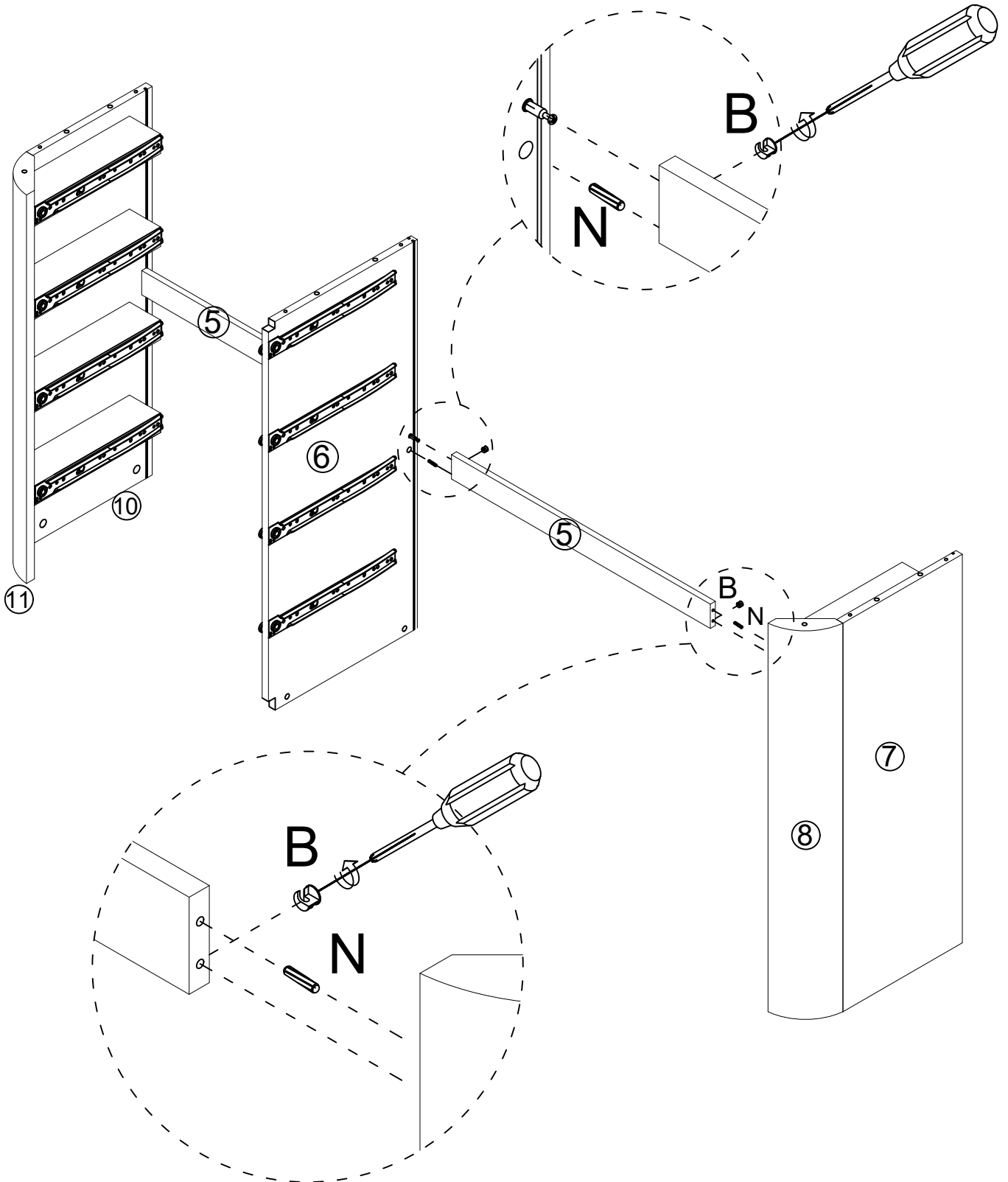
NOTE: It is recommended that 2 people assemble. One person needs to hold the boards to prevent them from falling over.



Step 16

N	C	D
		
X6	X8	X1

NOTE: It is recommended that 2 people assemble. One person needs to hold the boards to prevent them from falling over.

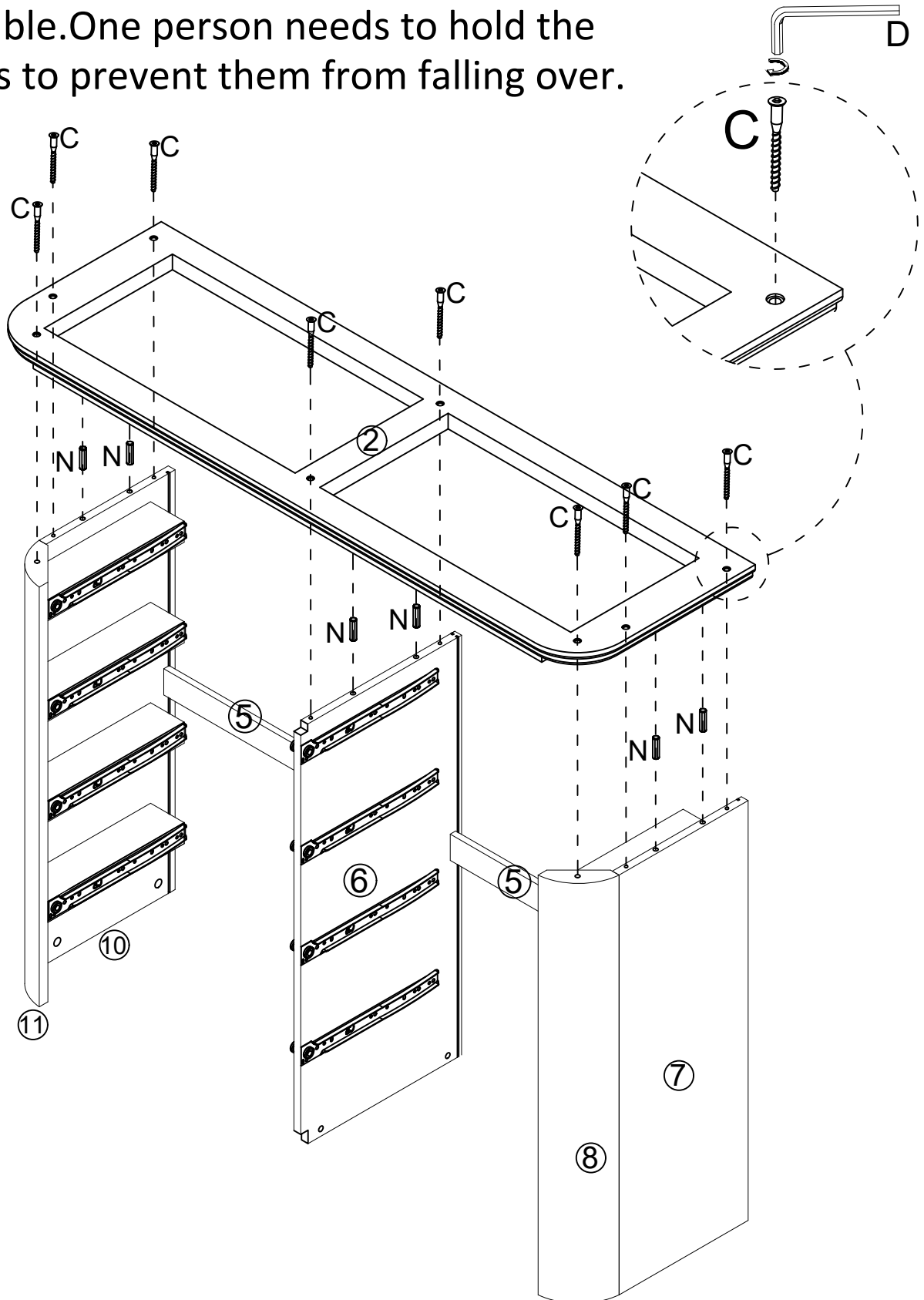

Step 17

Q



X6

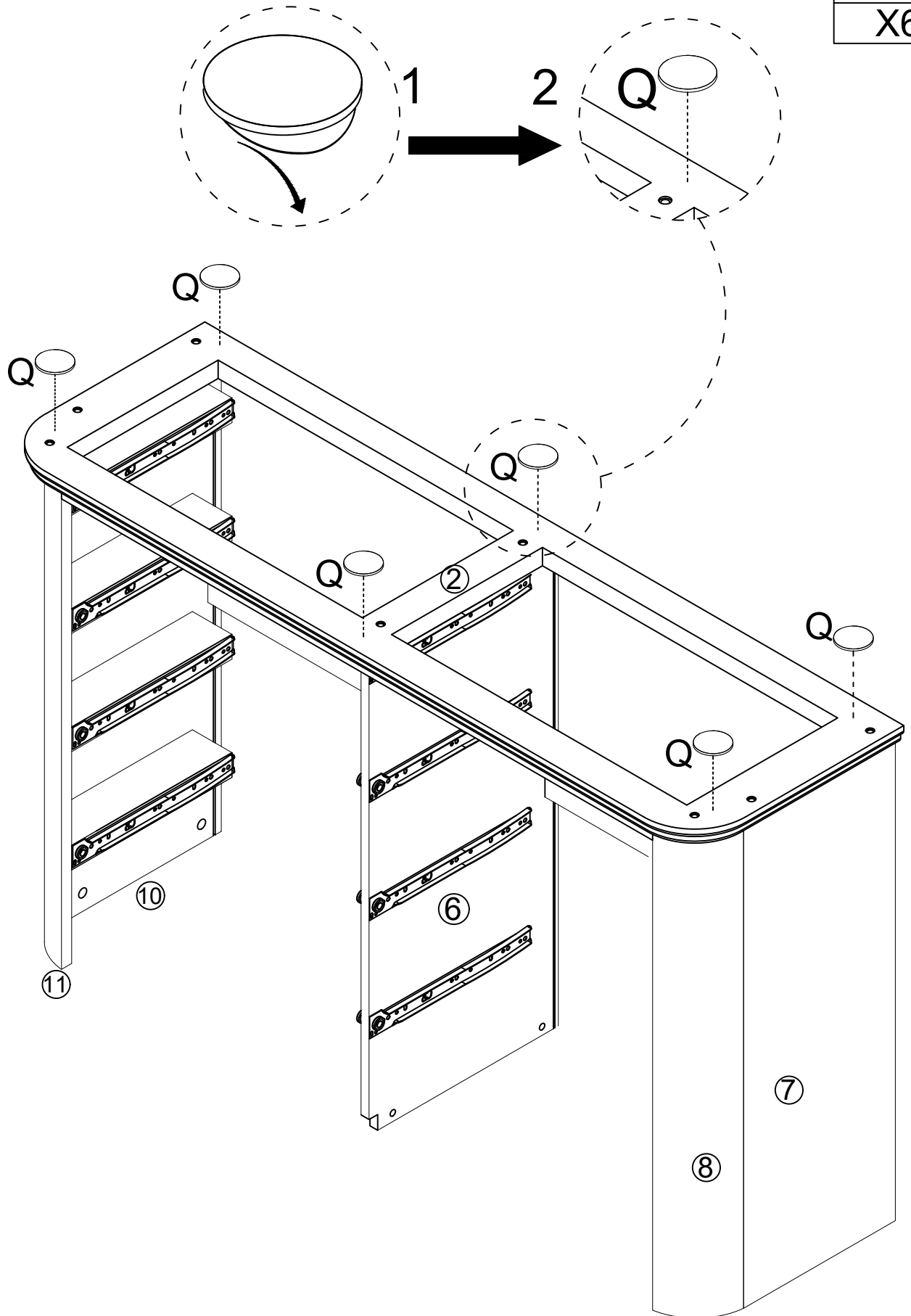

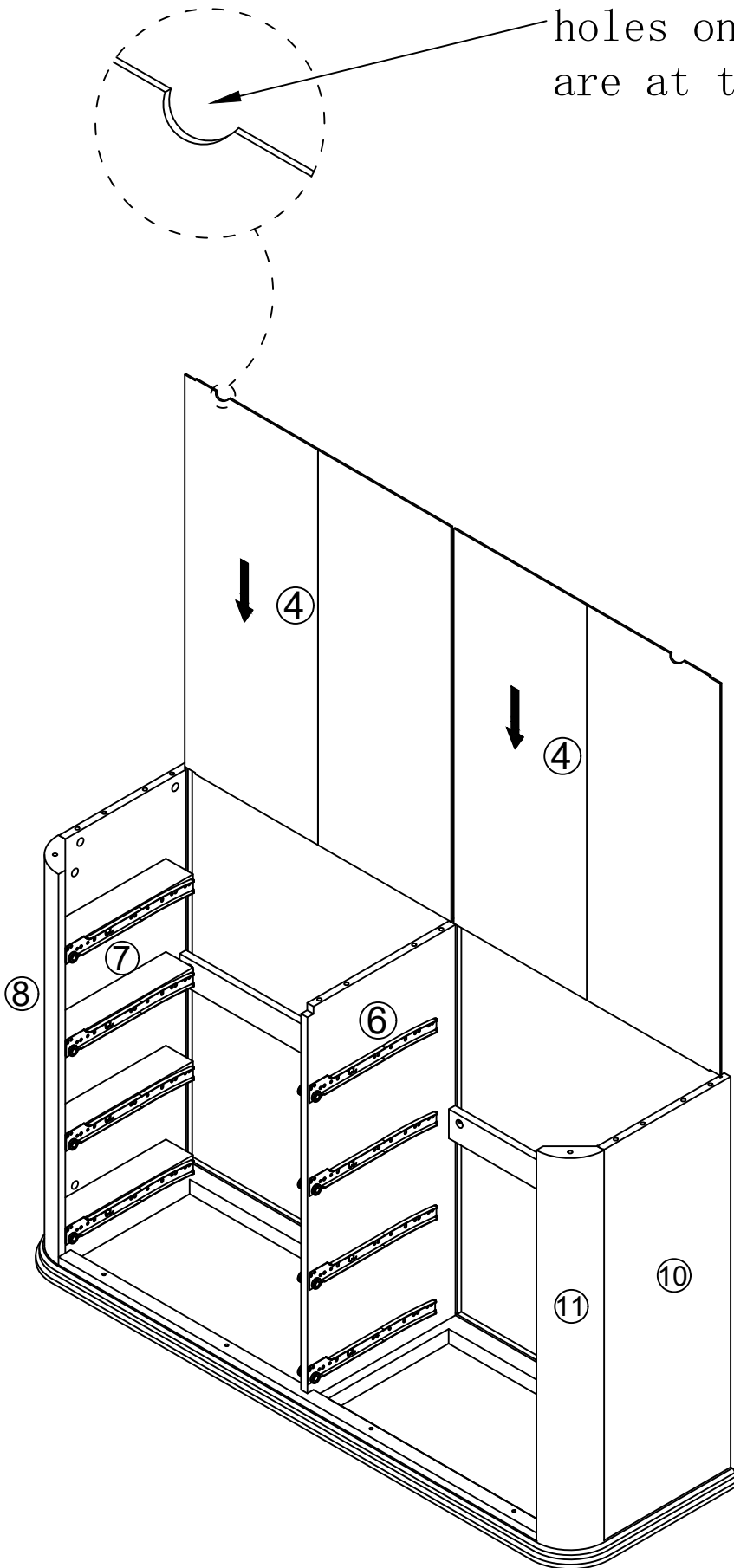

Step 18

Ensure the C-shaped holes on #4 back panel are at the top



Step 19

N	B
	
X6	X8

Note: This step is recommended for two people to complete together.

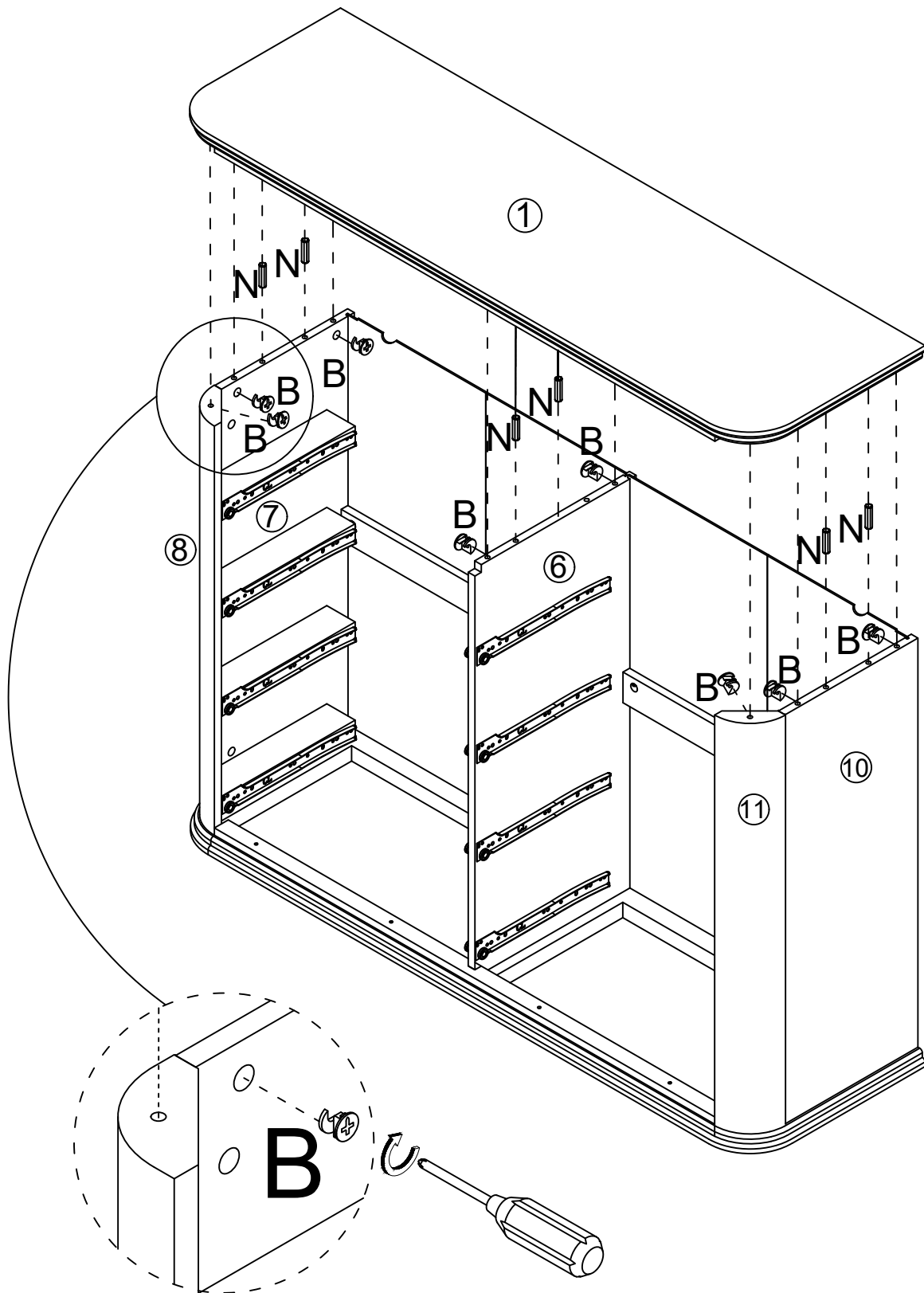

Step 20

M



O

X18

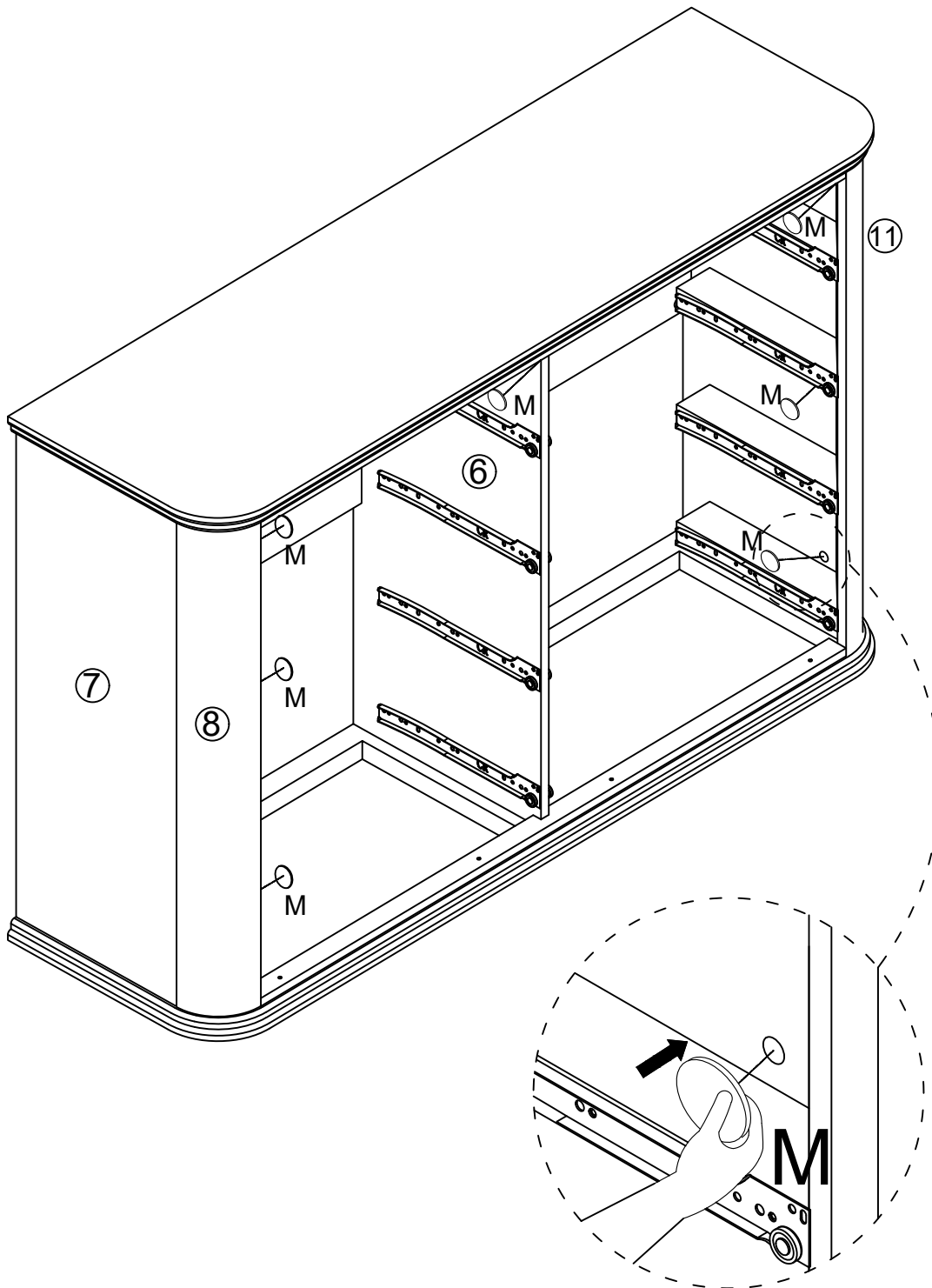
Notice: Covered all the cam lock holes with the sticker (M)

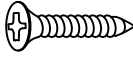

Step 21

F	E
	
X20	X20

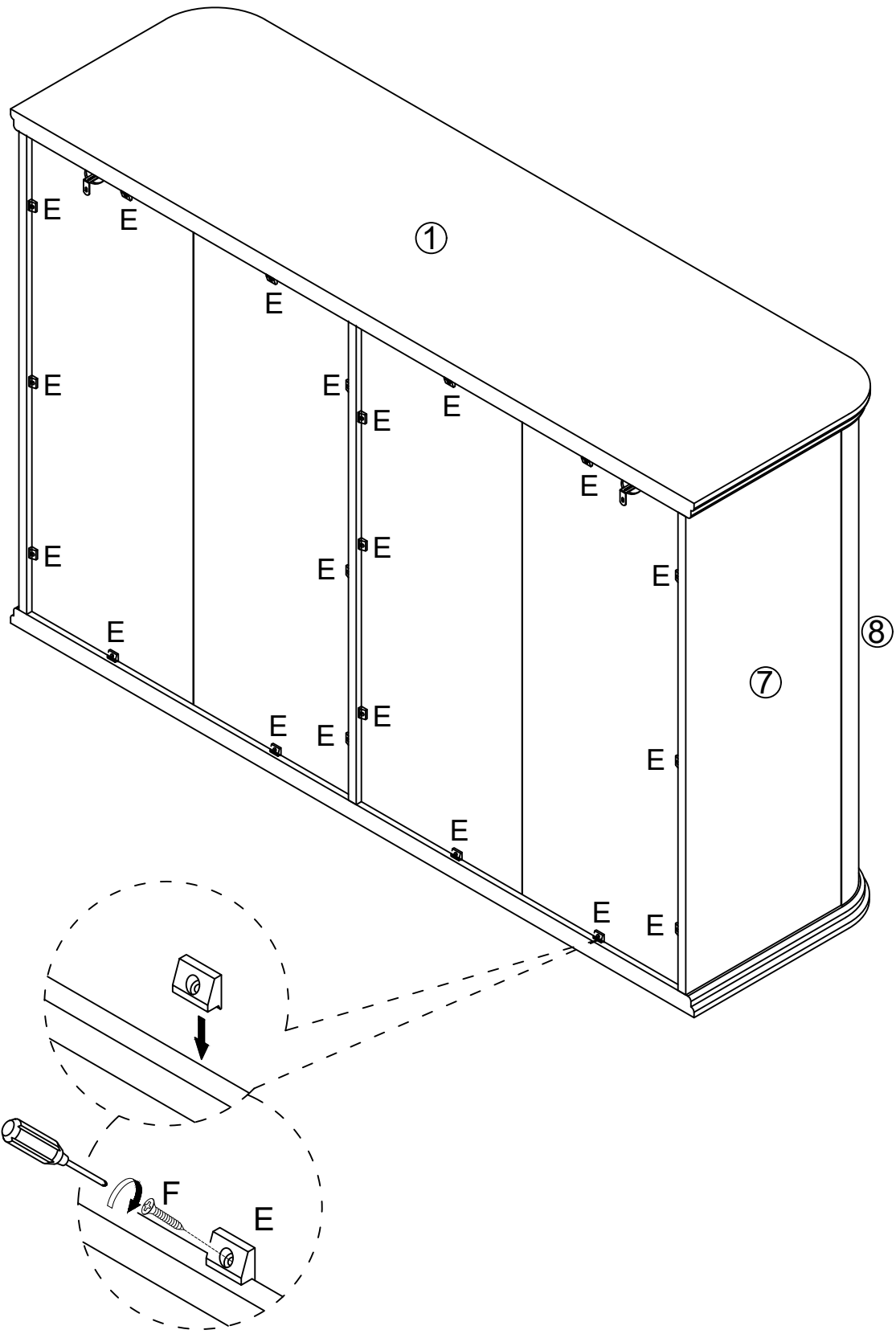

Step 22

MAKE TWO HOLES 45MM DEEP

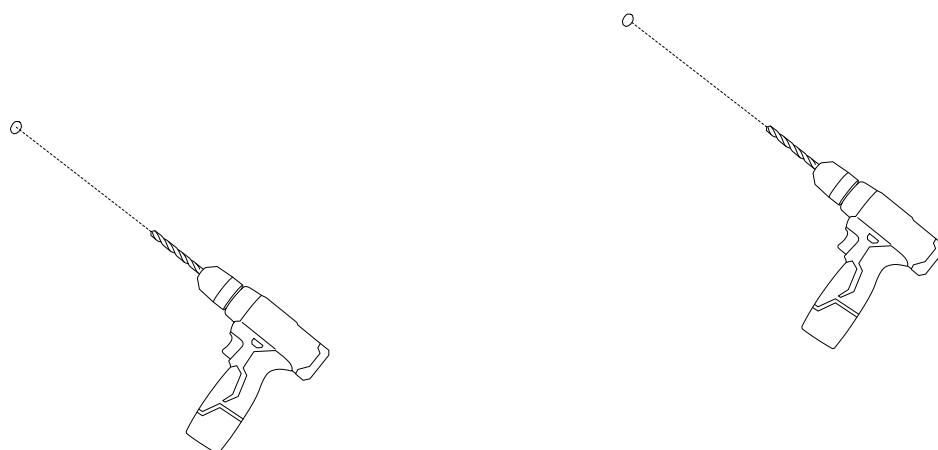

Wall

Step 23

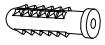
U

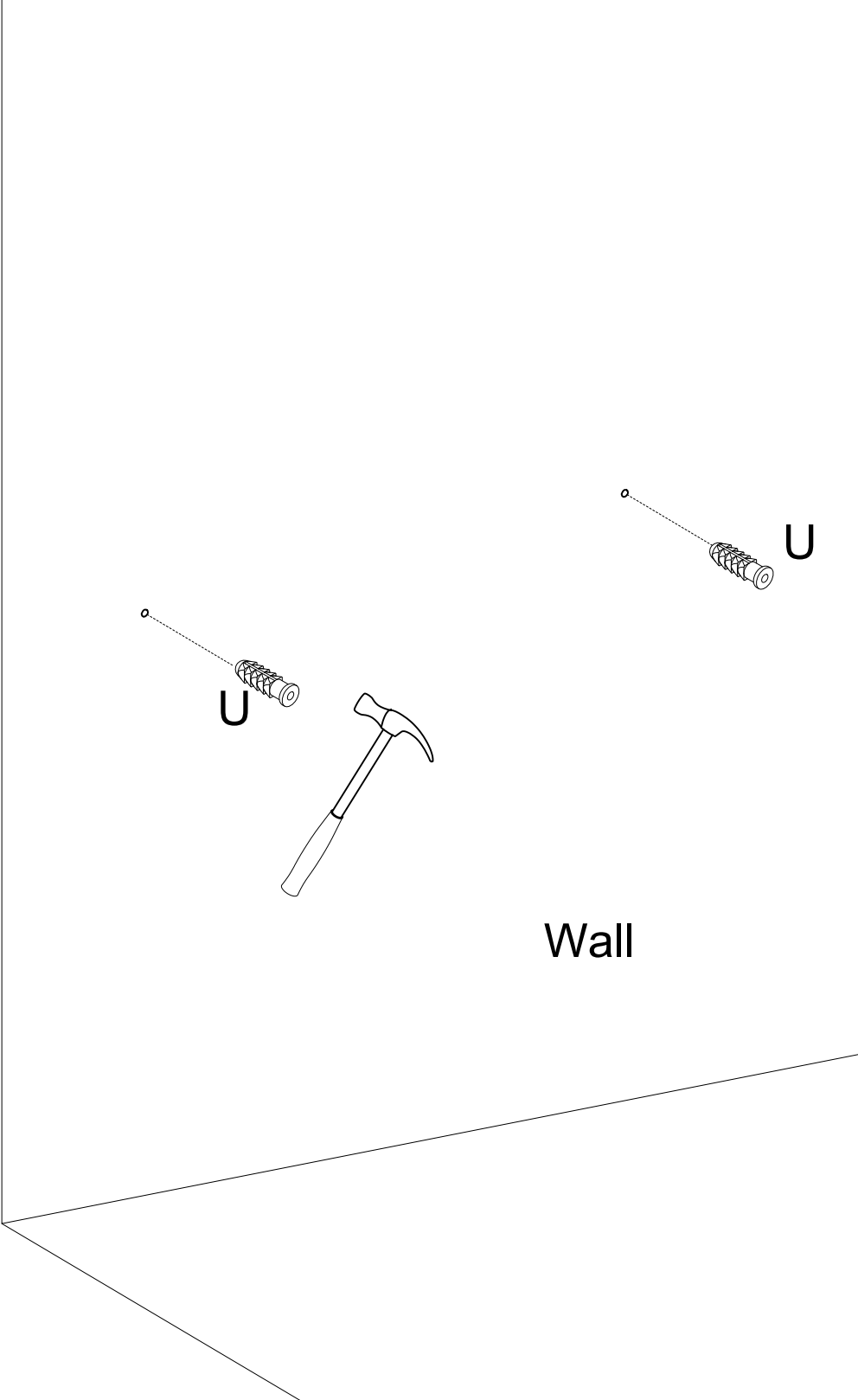
X2



Step 24

Note:According to the distance between the cabinet and the wall,adjust the #T fitting to the appropriate position ,and then tighten all the screw on the #T fitting

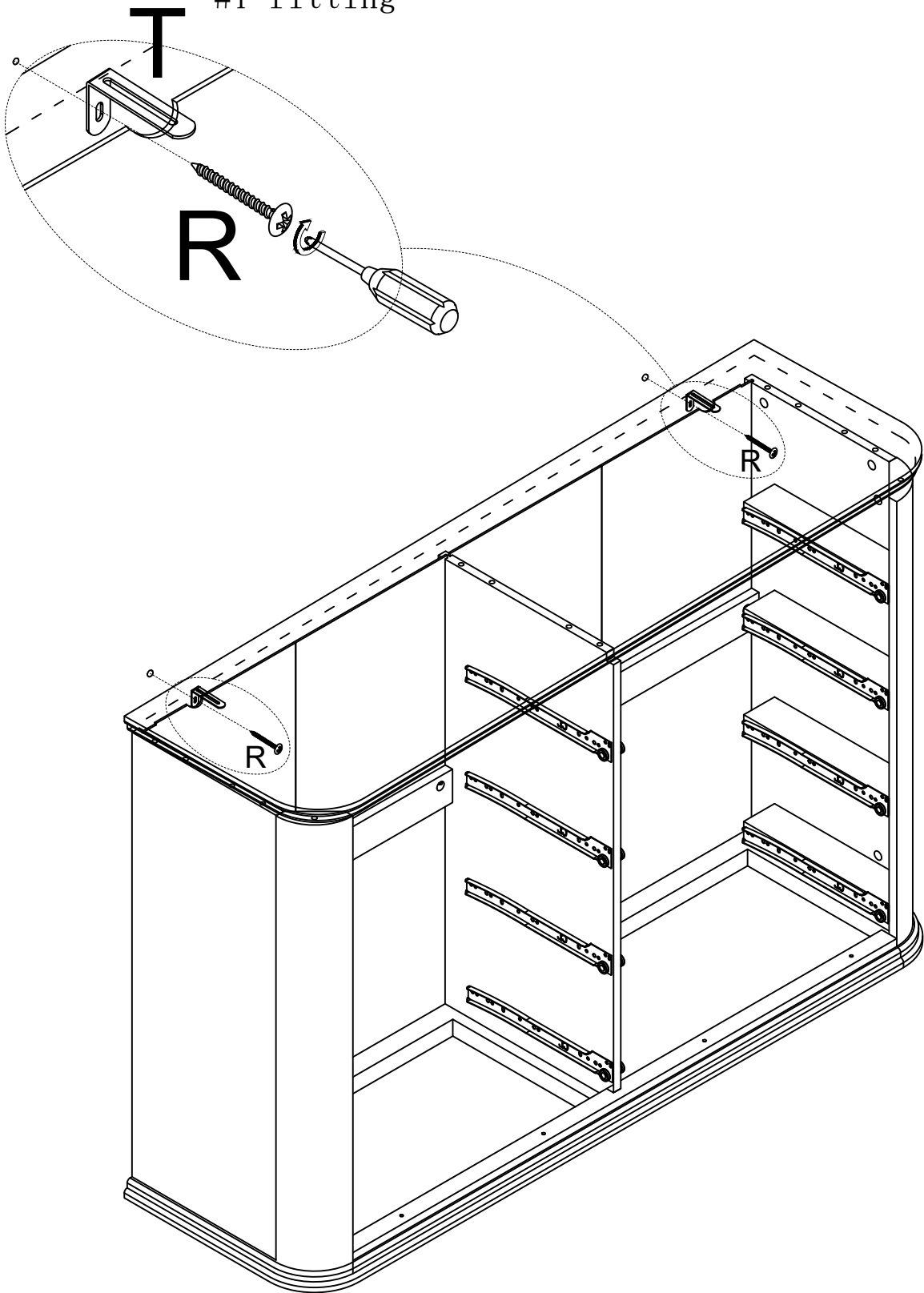
R

X2

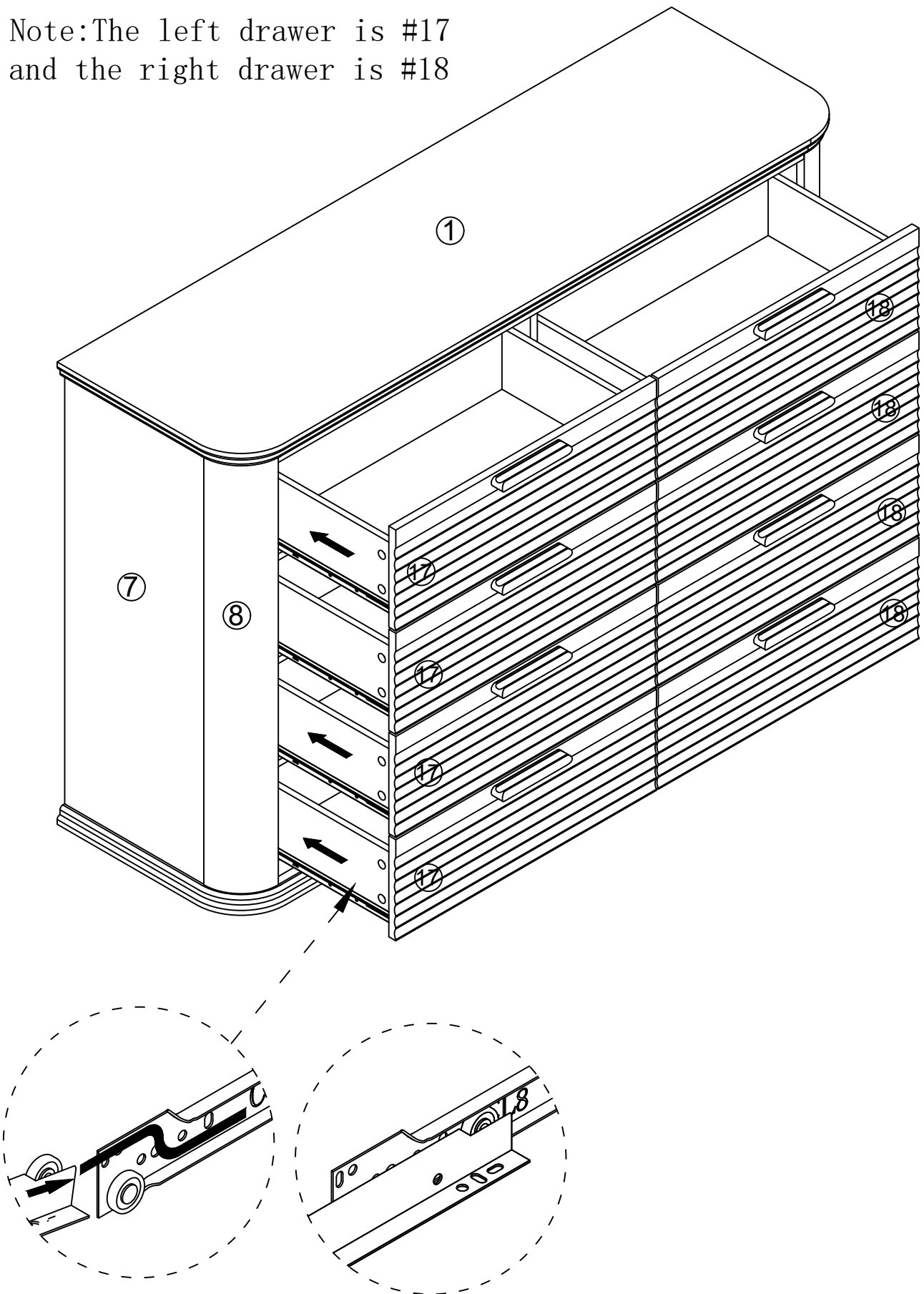

Step 25

Note: The left drawer is #17
and the right drawer is #18



Step 26

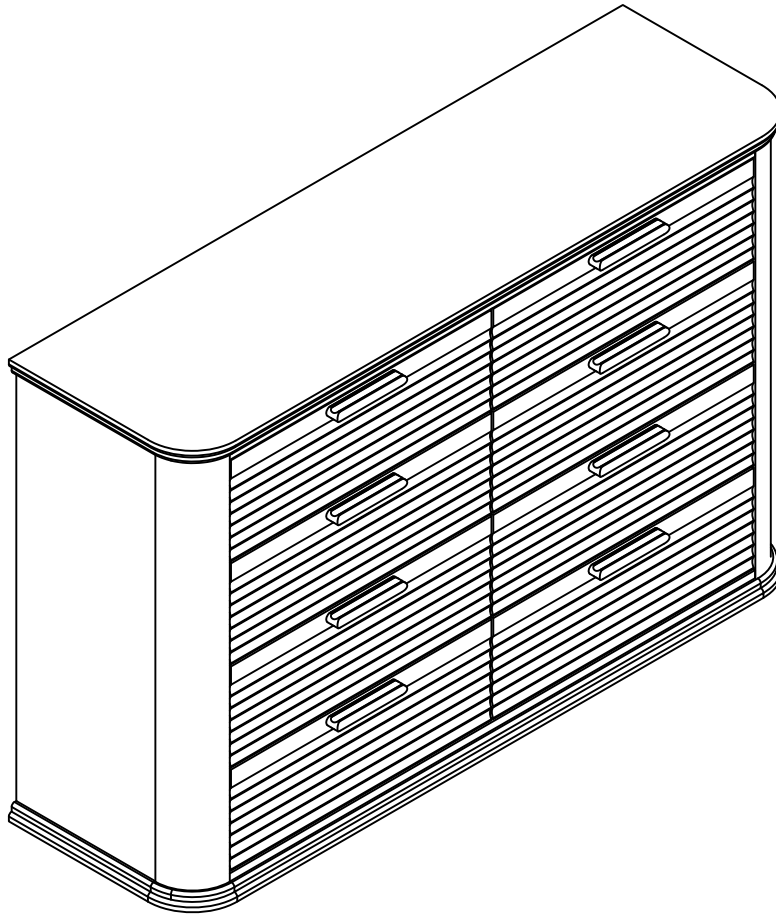

Step 27

WARNING



Children have died from furniture tipover. To reduce the risk of furniture tipover:

- **ALWAYS** install Anti-tip device provided.
- **NEVER** put a TV on this product.
- **NEVER** allow children to stand, climb or hang on drawers, doors, or shelves.
- **NEVER** open more than one drawer at a time.
- Place heaviest items in the lowest drawers.