

Assembly Instructions

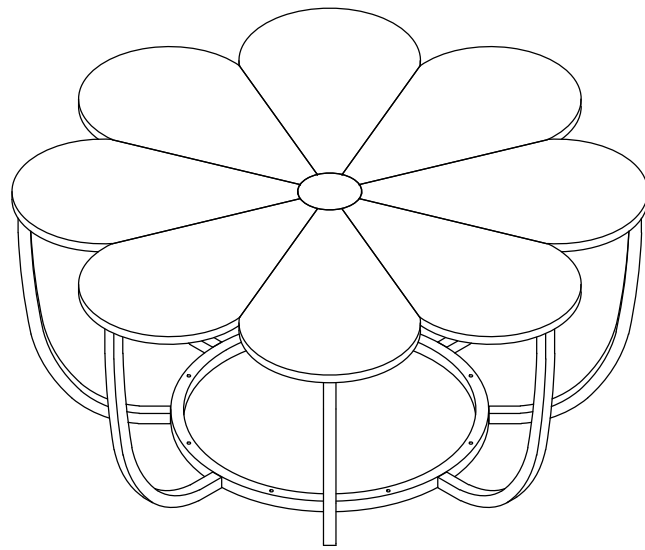

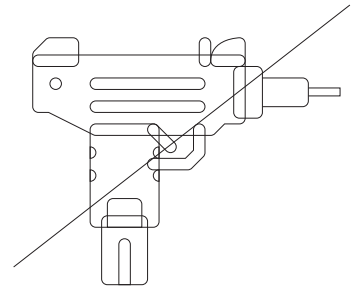
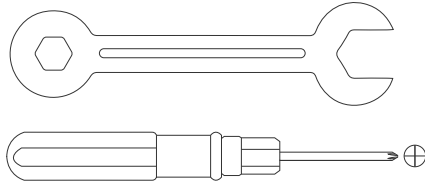
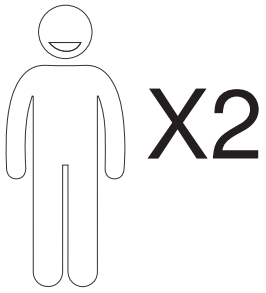

We recommend using hand tools for assembly.

If an electric screwdriver is used, reduce power and torque to avoid damage to the product.

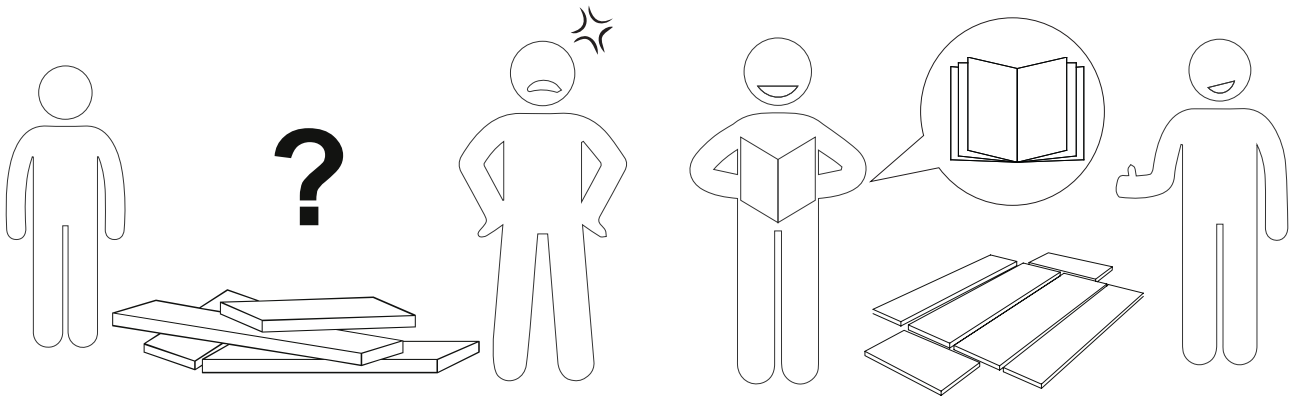

Install the Anti-Tip Straps

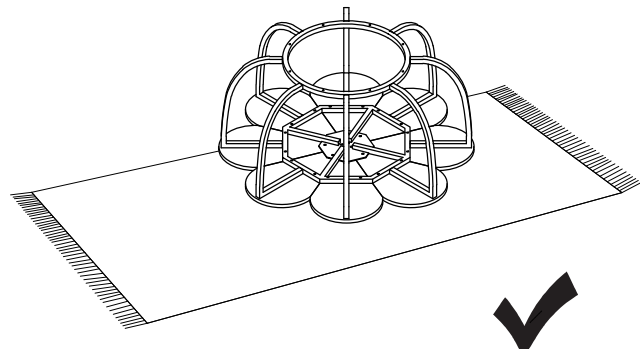
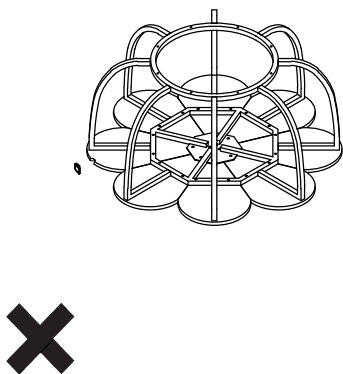

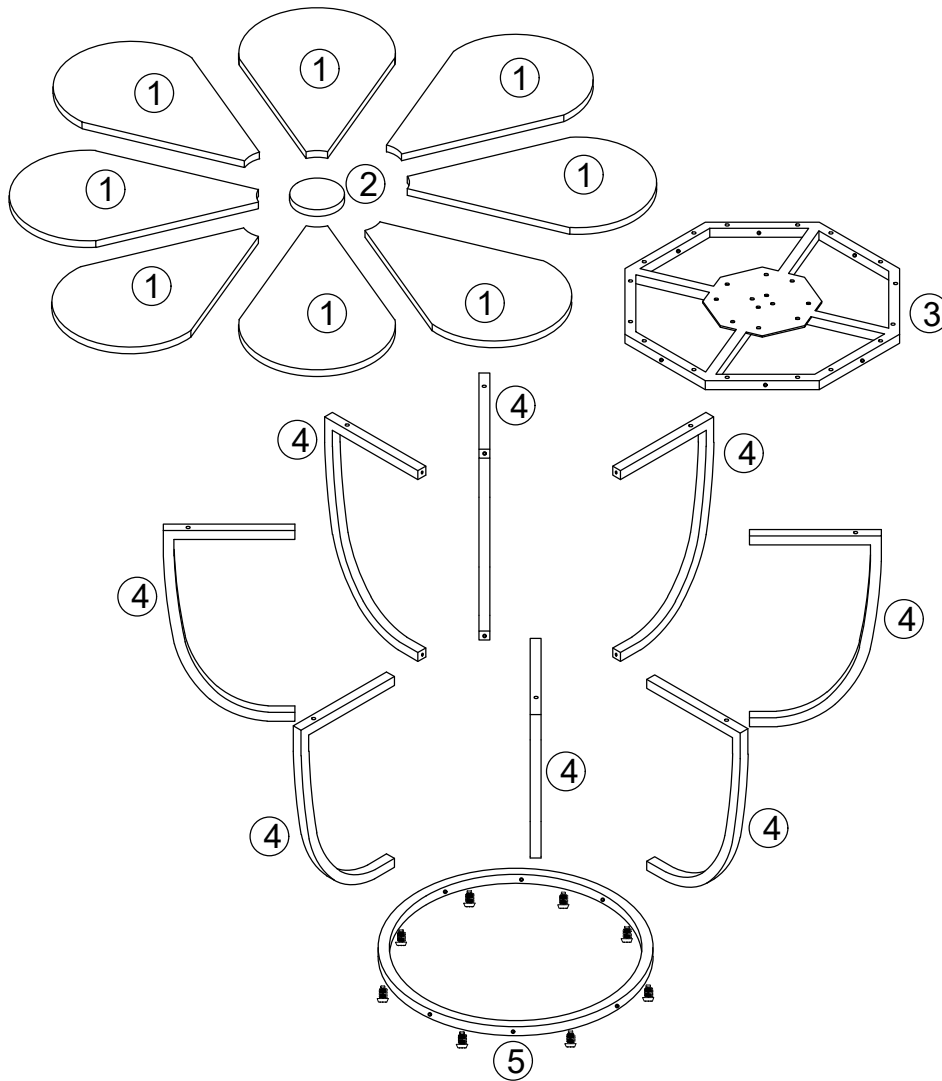







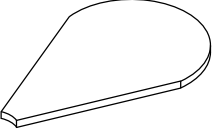

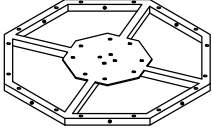
⚠ Caution

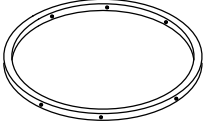
Make sure all parts are included. Most board parts are labeled or stamped on the raw edge. Contact us for a free replacement if you encounter any damaged or missing parts.

Parts List

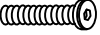
				
① 8 pcs	② 1 pc	③ 1 pc	④ 8 pcs	⑤ 1 pc

Hardware List

				
A 41 pcs	B 1 pc	C 8 pcs	D 10 pcs	

1

screw down

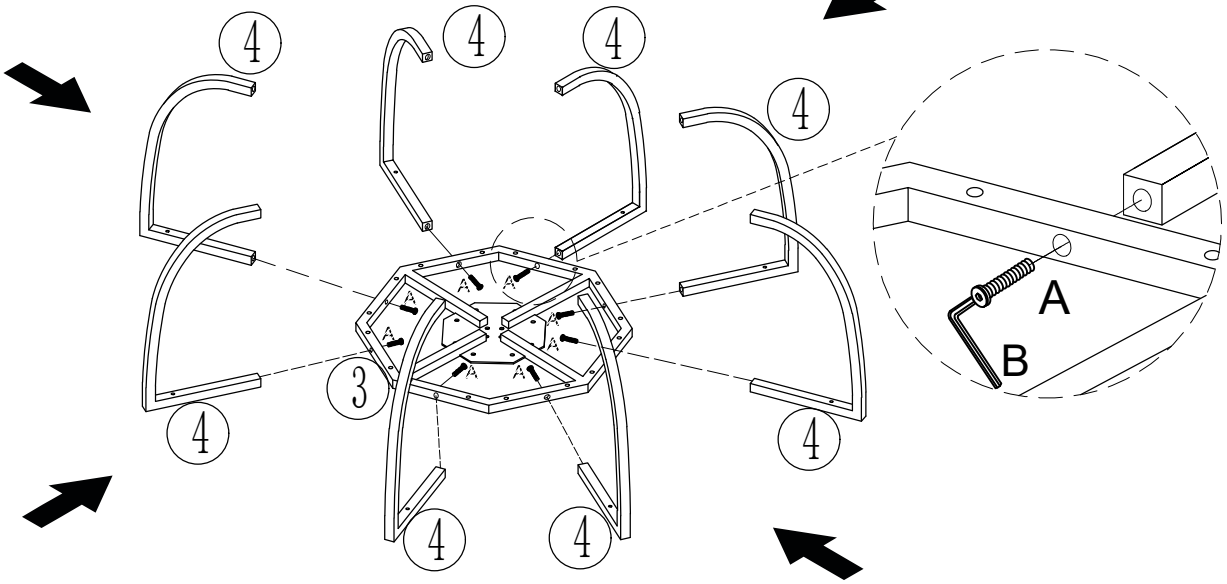
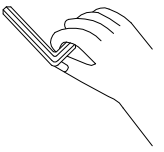

- A 8 pcs
- B 1 pc

2

screw down

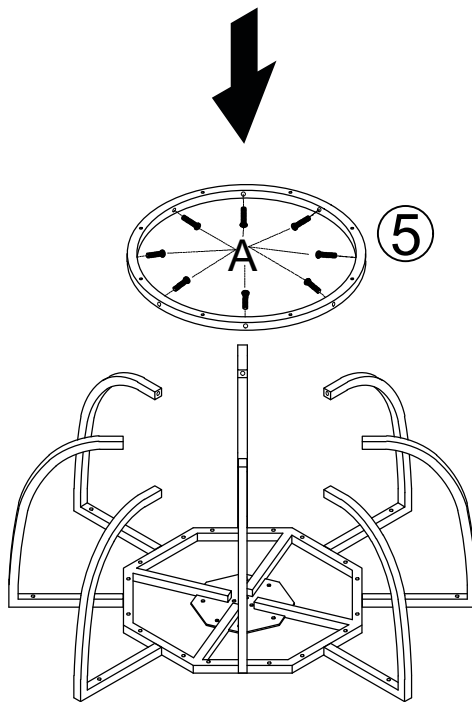
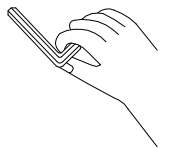

- A 8 pcs
- B 1 pc

3



screw down

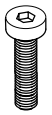
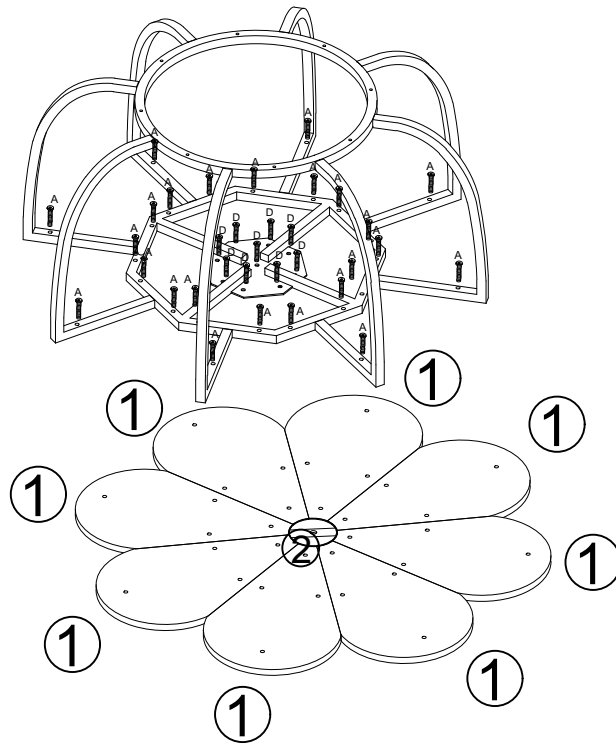
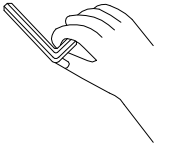

A
24PCS



B
1 pc



D
9PCS

4

screw down

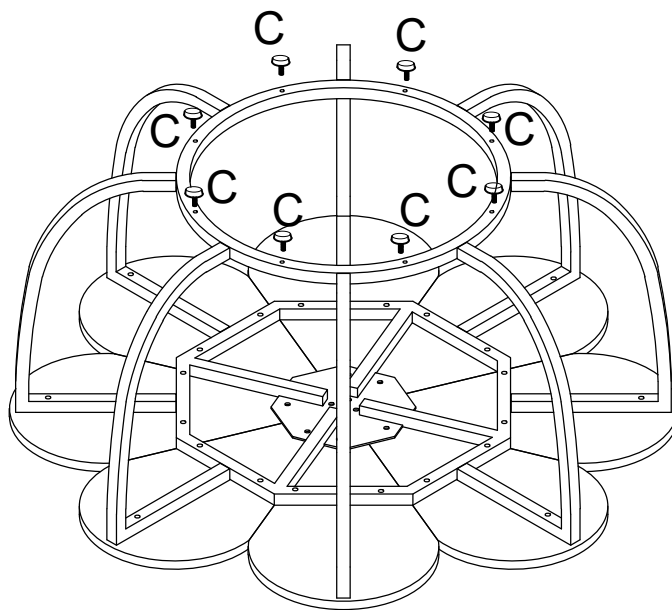
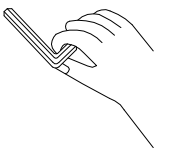

C
8 pcs

5

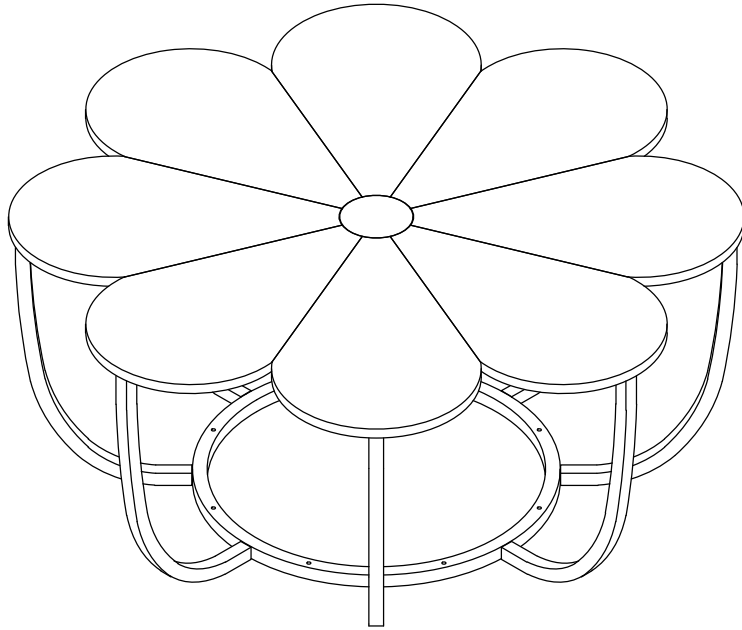

Thank you for your support!

