

MANUAL INSTRUCTION

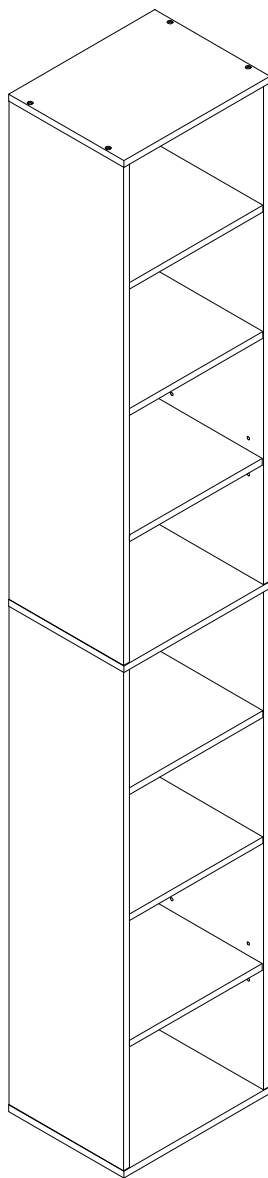

Bookcase
Bücherregale
Bibliothèque
Librería
Libreria
カラーボックス

We offer a diverse range of products
to meet the needs of customers.



US:service@kmcglobe-us.com
FR:service@kmcglobe-fr.com
JP:service@kmcglobe-jp.com

UK:service@kmcglobe-uk.com
ES:service@kmcglobe-es.com

DE:service@kmcglobe-de.com
IT:service@kmcglobe-it.com



(+1) 559-354-1889(ONLY US)



English

Warnings

- The product must be assembled and used in accordance with the provisions of the manual. The seller does not assume any responsibility or liability with respect for any damage caused by incorrect assembly or improper use.
- It is strictly prohibited to sit or stand on the product.
- During the assembly process, keep any small parts out of the reach of children. It may be fatal if swallowed or inhaled.
- To avoid the potential dangers of suffocation, please keep all parts and packaging (films, plastic bags, and foam, etc.) away from babies and children.
- If there is/are defective and/or missing part(s) after unpacking, please cease assembly immediately and get in contact with us as soon as possible.

Français

Avertissements

- Le produit doit être assemblé et utilisé conformément aux dispositions du manuel. Le vendeur n'assume aucune responsabilité pour tout dommage causé par un assemblage incorrect ou une utilisation inappropriée.
- Il est strictement interdit de s'asseoir ou de se tenir debout sur le produit.
- Pendant l'assemblage, gardez les petites pièces hors de portée des enfants. Elles peuvent être mortelles en cas d'ingestion ou d'inhalation.
- Pour éviter tout risque d'étouffement, veuillez garder toutes les pièces et emballages (films, sacs plastiques, mousse, etc.) hors de portée des bébés et des enfants.
- S'il y a des pièces défectueuses et/ou manquantes après le déballage, cessez immédiatement l'assemblage et contactez-nous dès que possible.

Deutsch

Warnungen

- Das Produkt muss gemäß den Bestimmungen des Handbuchs montiert und verwendet werden. Der Verkäufer übernimmt keine Verantwortung oder Haftung für Schäden, die durch falsche Montage oder unsachgemäße Verwendung verursacht werden.
- Es ist strengstens verboten, auf dem Produkt zu sitzen oder zu stehen.
- Halten Sie während des Montagevorgangs kleine Teile außerhalb der Reichweite von Kindern. Verschlucken oder Einatmen kann tödlich sein.
- Um mögliche Erstickungsgefahren zu vermeiden, halten Sie alle Teile und Verpackungen (Folien, Plastiktüten und Schaumstoffe usw.) von Babys und Kindern fern.
- Wenn nach dem Auspacken defekte und/oder fehlende Teile vorhanden sind, stellen Sie die Montage sofort ein und kontaktieren Sie uns so bald wie möglich.

Español

Advertencias

- El producto debe ser ensamblado y utilizado de acuerdo con las disposiciones del manual. El vendedor no asume ninguna responsabilidad por daños causados por un ensamblaje incorrecto o un uso inadecuado.
- Está estrictamente prohibido sentarse o pararse sobre el producto.
- Durante el proceso de montaje, mantenga las piezas pequeñas fuera del alcance de los niños. Puede ser fatal si se ingiere o inhala.
- Para evitar el riesgo de asfixia, mantenga todas las piezas y el embalaje (películas, bolsas de plástico, espuma, etc.) fuera del alcance de bebés y niños.
- Si después de desempacar hay piezas defectuosas y/o faltantes, detenga el montaje de inmediato y póngase en contacto con nosotros lo antes posible.

Italiano

Avvertenze

- Il prodotto deve essere assemblato e utilizzato in conformità con le disposizioni del manuale. Il venditore non si assume alcuna responsabilità per eventuali danni causati da un assemblaggio errato o da un uso improprio.
- È severamente vietato sedersi o stare in piedi sul prodotto.
- Durante il processo di assemblaggio, tenere le piccole parti fuori dalla portata dei bambini. Può essere letale se ingerito o inalato. Per evitare il rischio di soffocamento, tenere
- tutte le parti e gli imballaggi (pellicole, sacchetti di plastica, schiuma, ecc.) lontano da neonati e bambini.
Se dopo aver aperto la confezione si riscontrano parti difettose e/o mancanti, interrompere immediatamente l'assemblaggio e contattarci il prima possibile.

日本語

警告

- 本製品はマニュアルの指示に従って組み立ておよび使用してください。誤った組み立てや不適切な使用によって生じた損害について、販売者は一切の責任を負いません。
- 製品の上に座ったり立ったりすることは厳禁です。
- 組み立て中は、小さな部品を子供の手の届かないところに保管してください。誤って飲み込んだり吸い込んだりすると致命的な危険があります。
- 窒息の危険性を避けるため、全ての部品や包装材（フィルム、ビニール袋、フォームなど）を乳児や子供から遠ざけてください。
- 開梱後、部品が欠陥または不足している場合は、直ちに組み立てを中止し、できるだけ早くご連絡ください。

PARTS

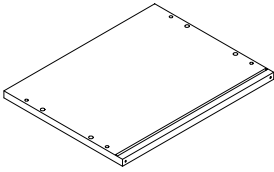

1 x1

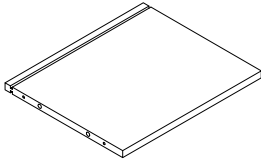

2 x4

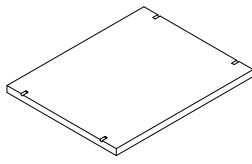

3 x2

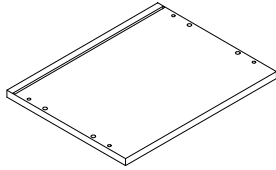

4 x1

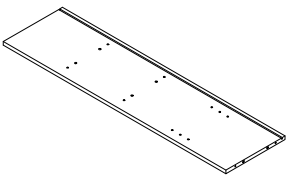

5 x1

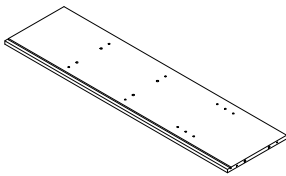

6 x1

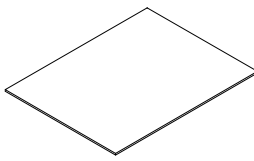

7 x4

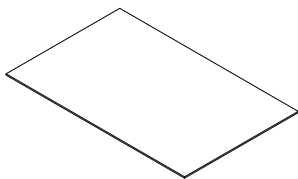

8 x2

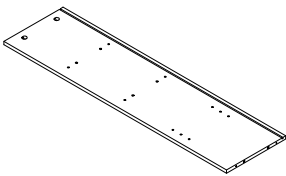

9 x1

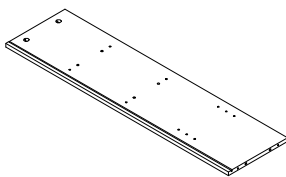

10 x1

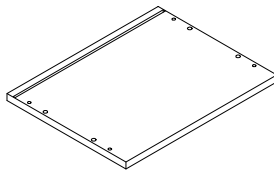

11 x1

HARDWARE



Φ6x35mm

A x4



Φ15x9mm

B x4



M4x40mm

C x30



Φ6x30mm

D x32

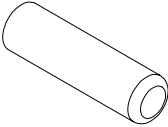

Φ5x20mm

E x8



Φ20mm

F x20



G x2



M3x14mm

H x26

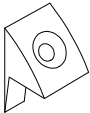

I x24

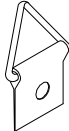

J x4

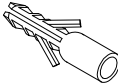

Φ6x30mm

K x2

EXPLOSION DIAGRAM

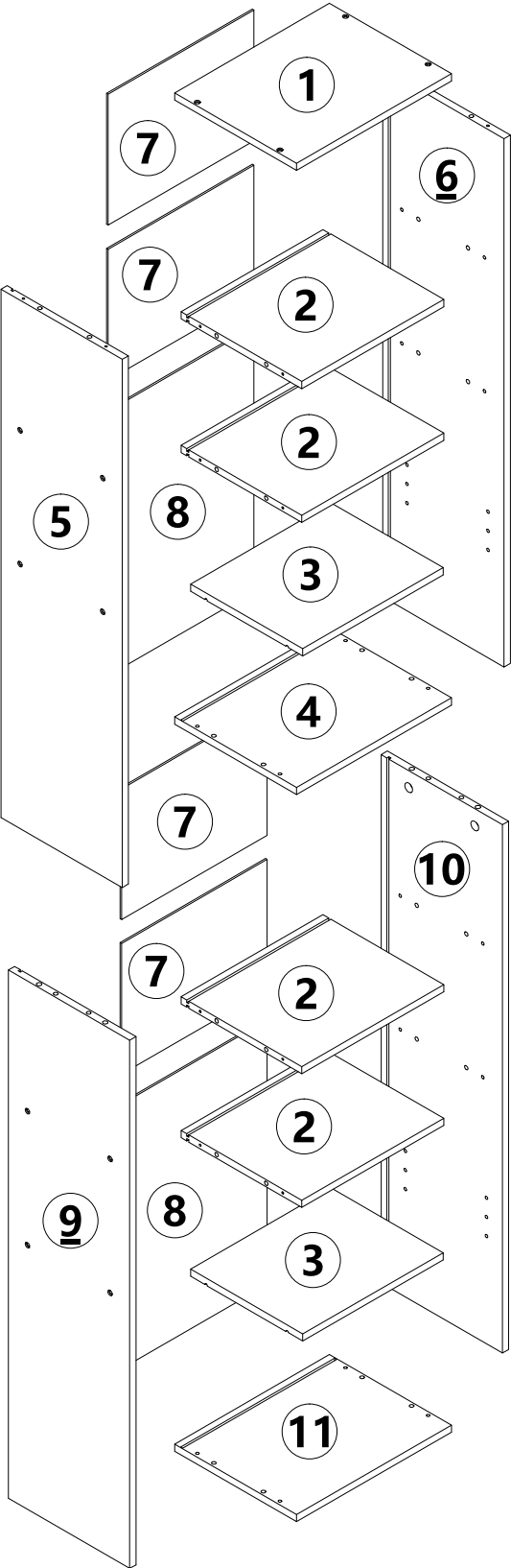

1



D x16

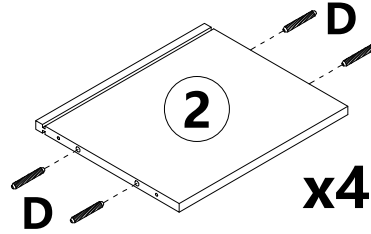

2



C x4

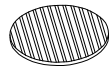

F x4

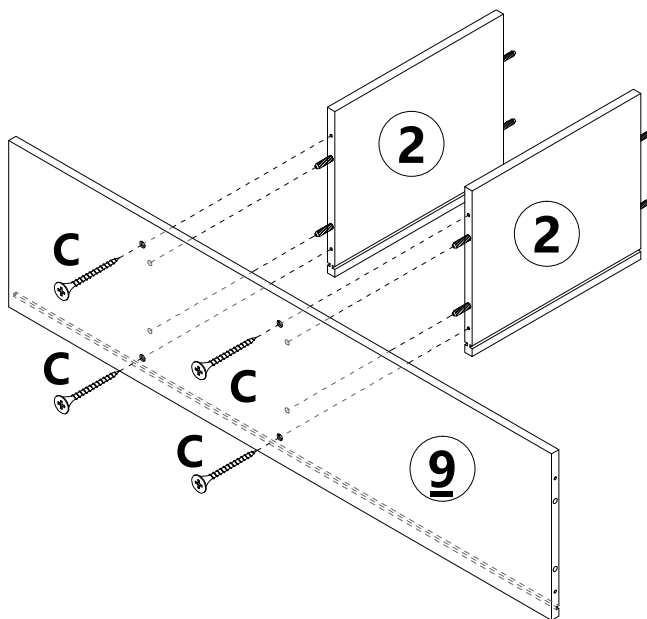
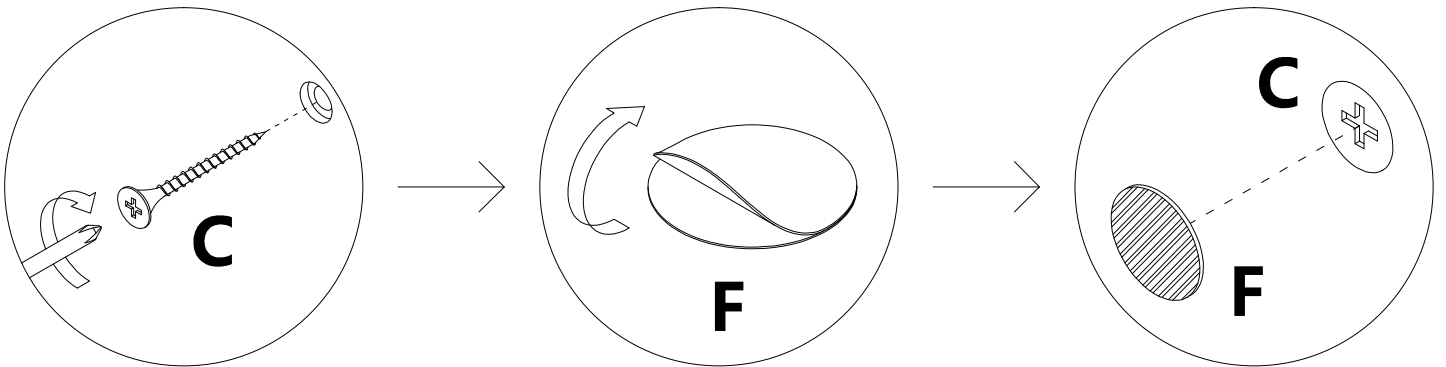

90°

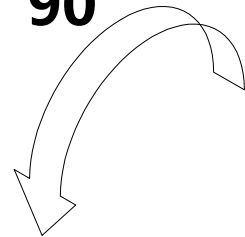

3

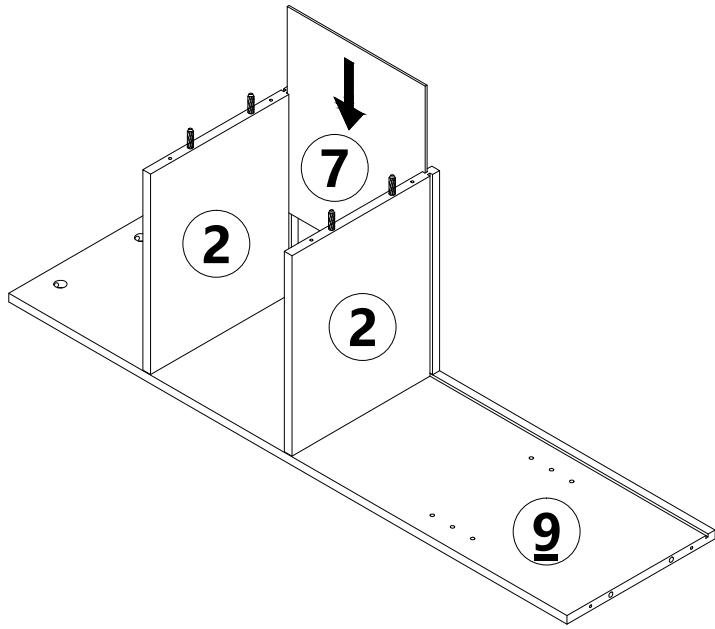

4

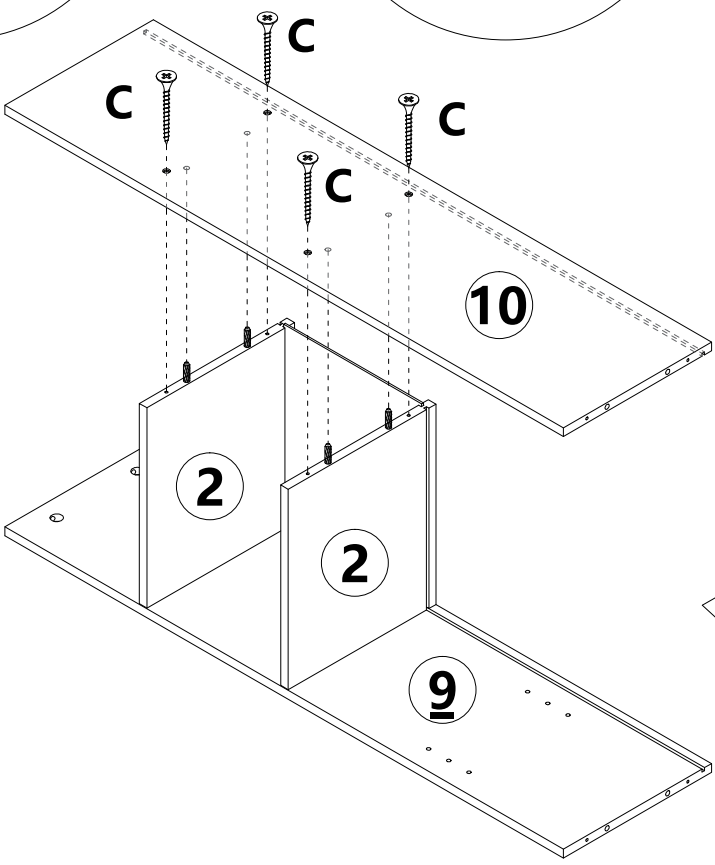
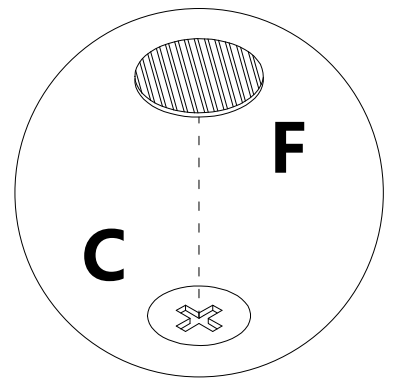
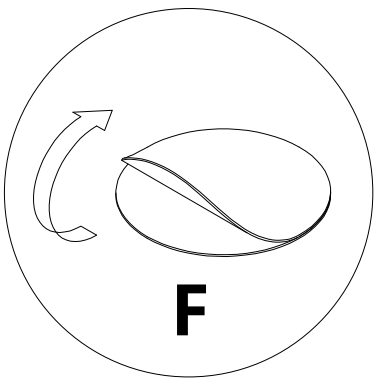
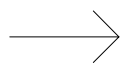
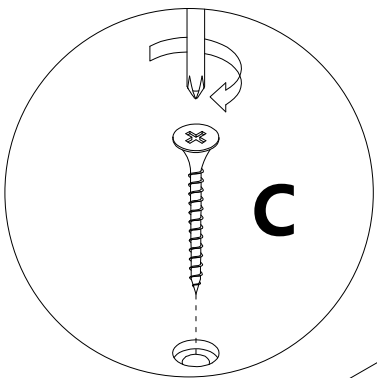

90°

5

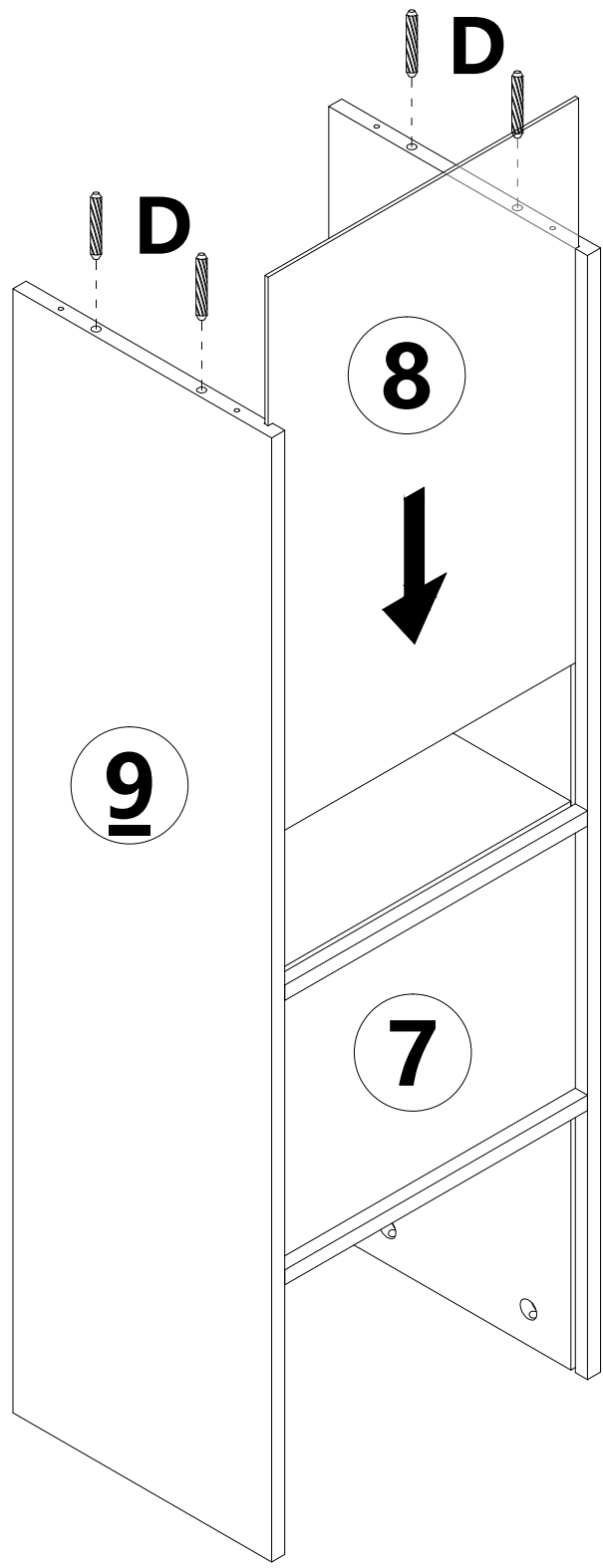
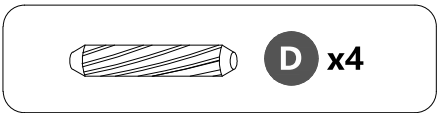

6

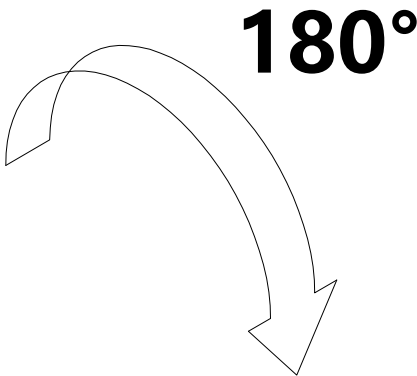
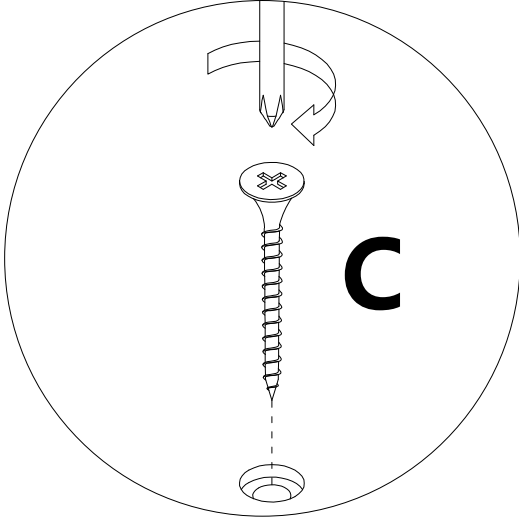
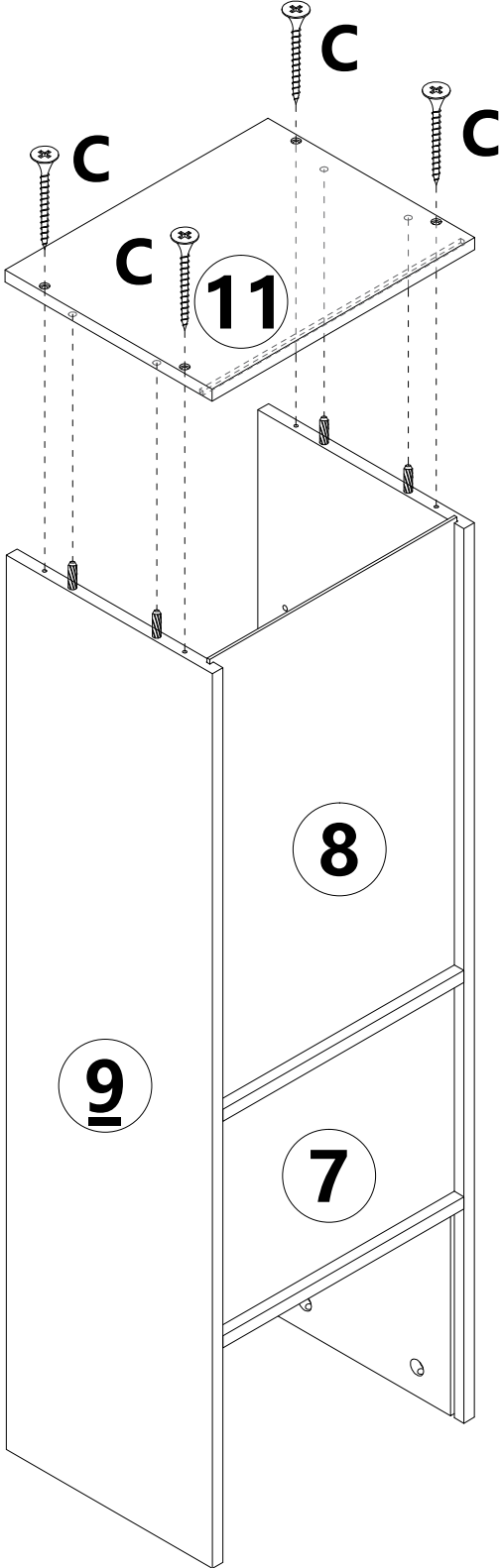
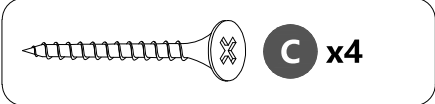

7

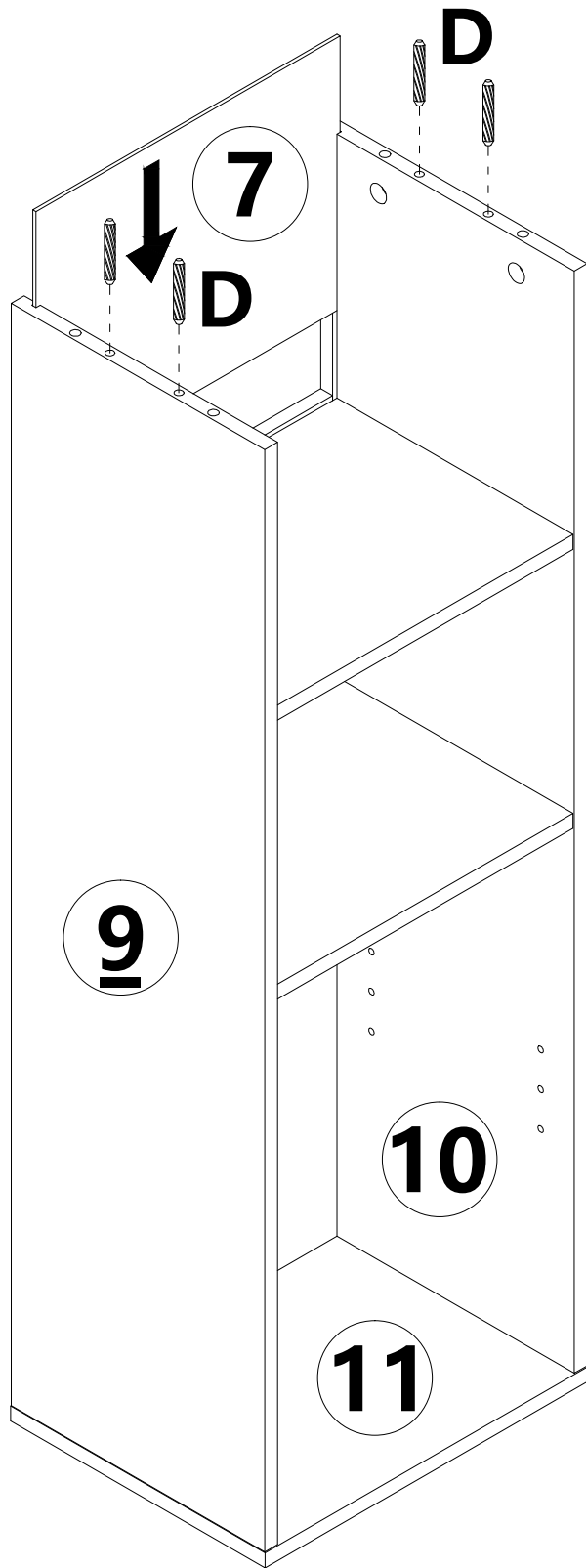
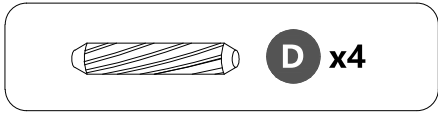

8

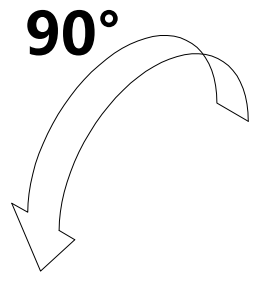
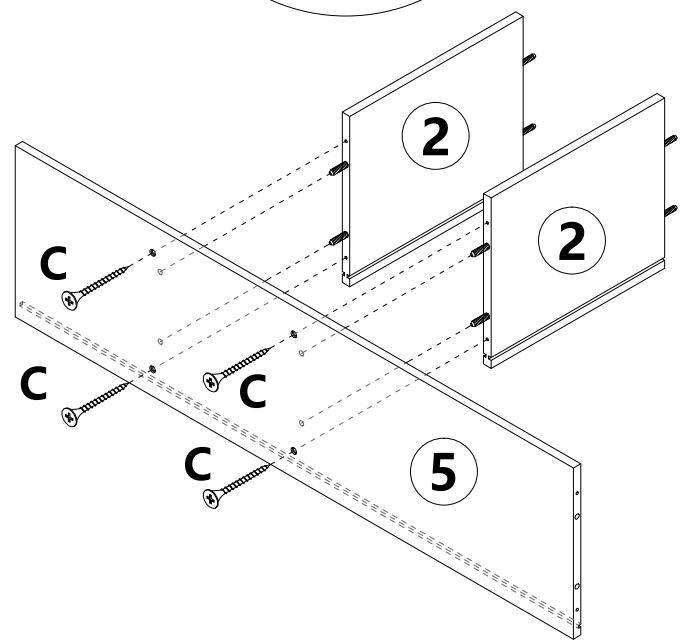
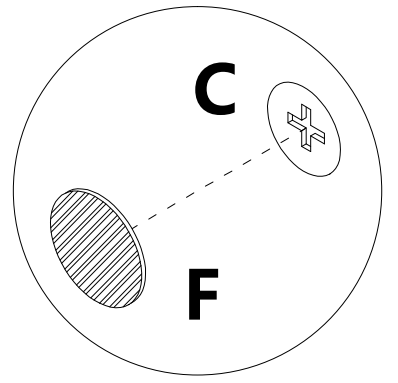
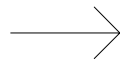
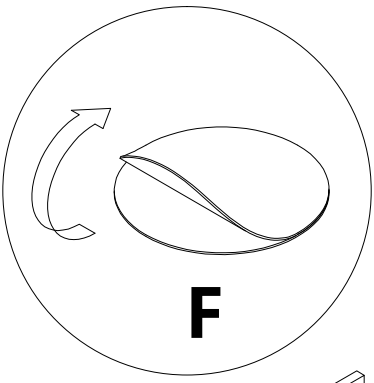
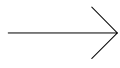
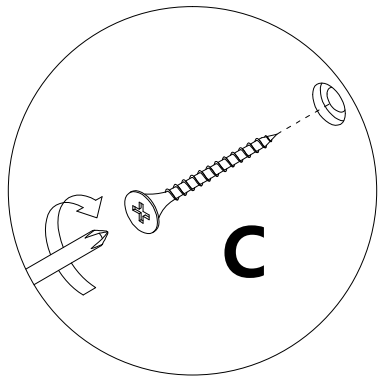

9

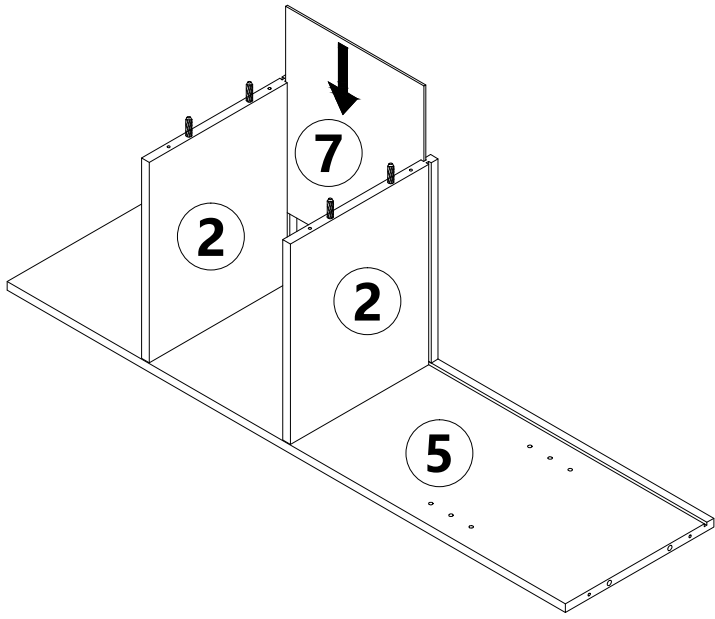

10

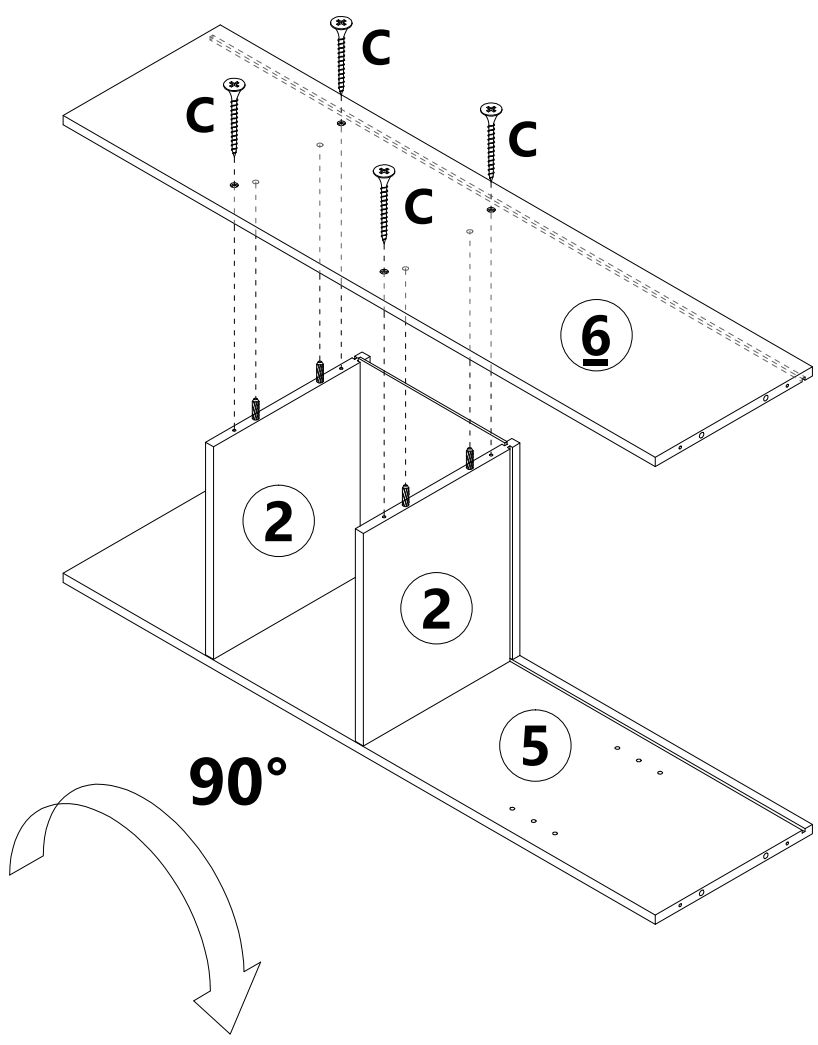
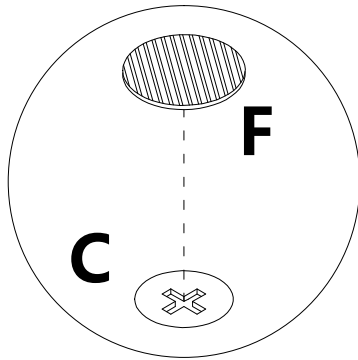
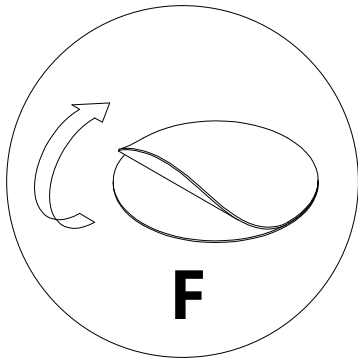
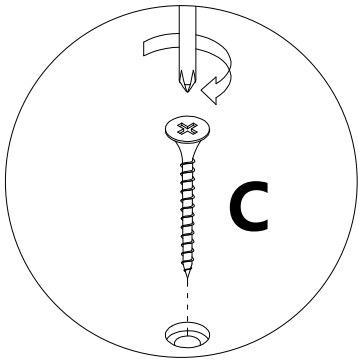

11

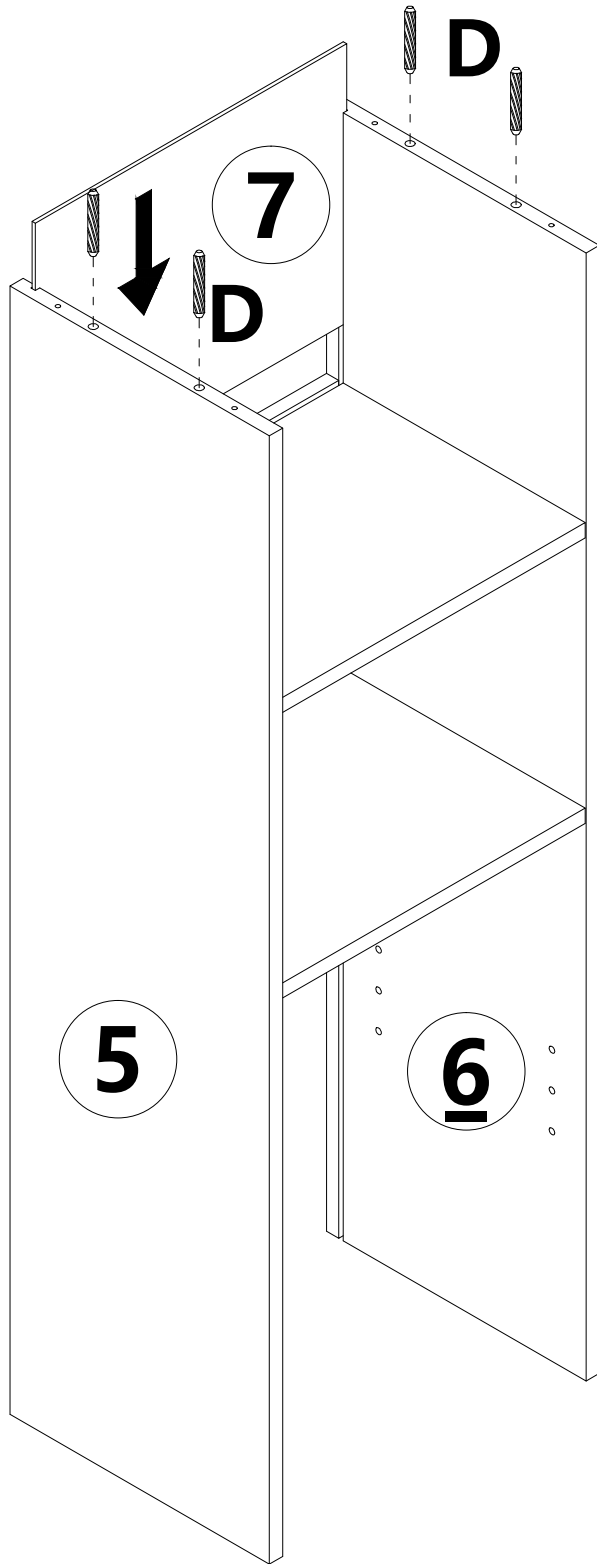
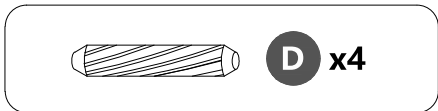

12

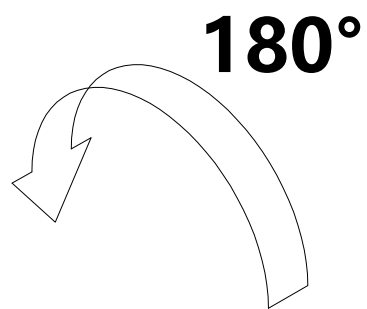
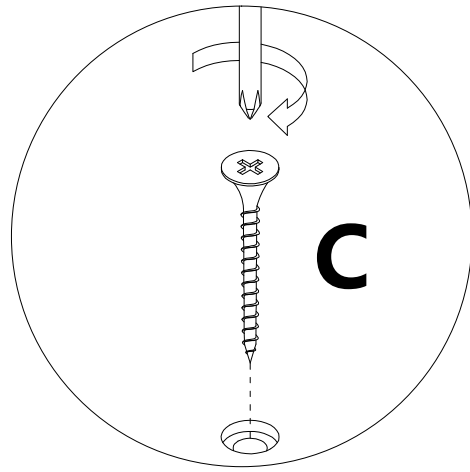
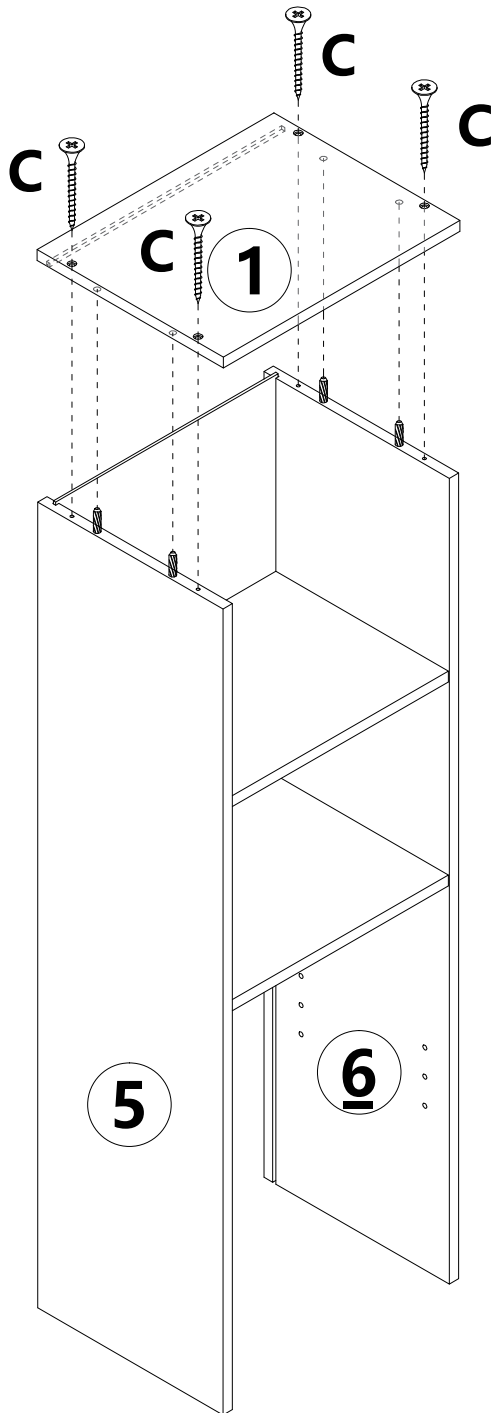
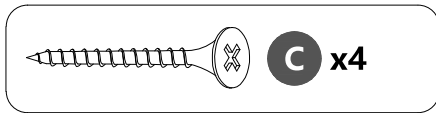

13

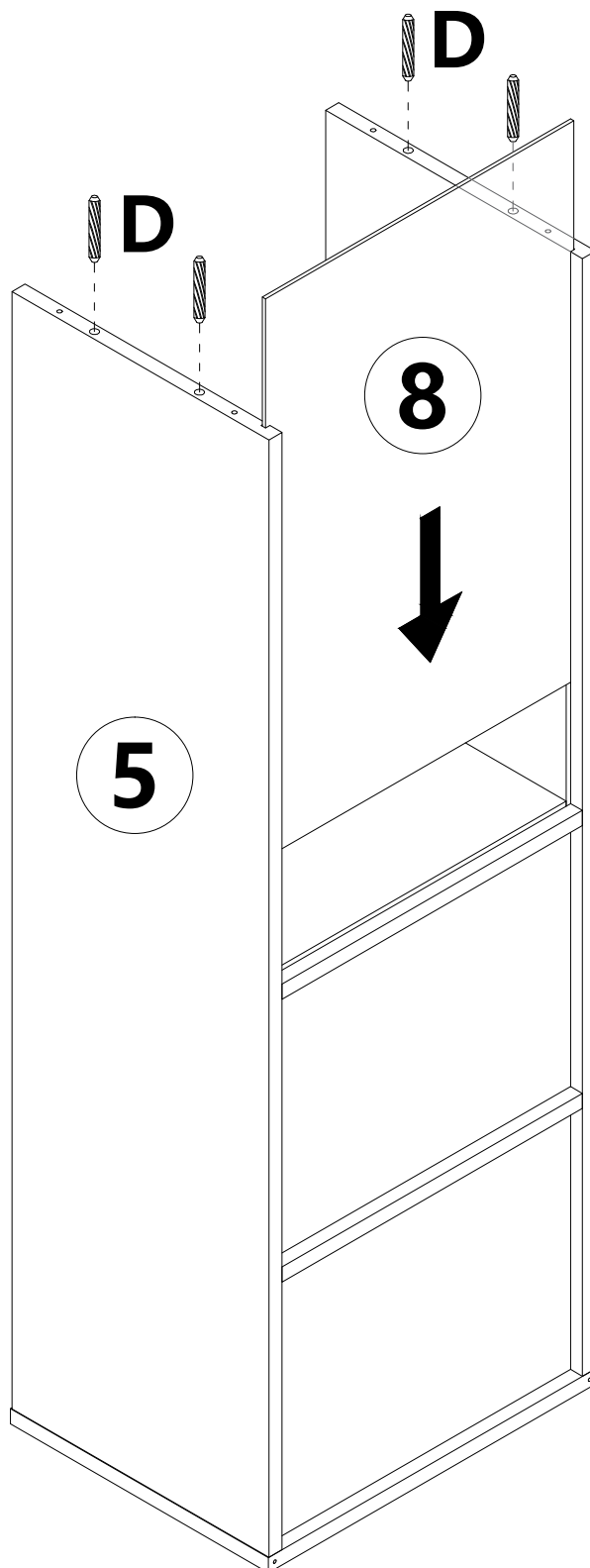
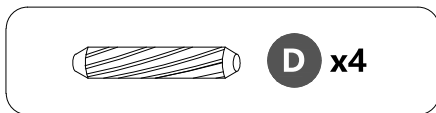

14

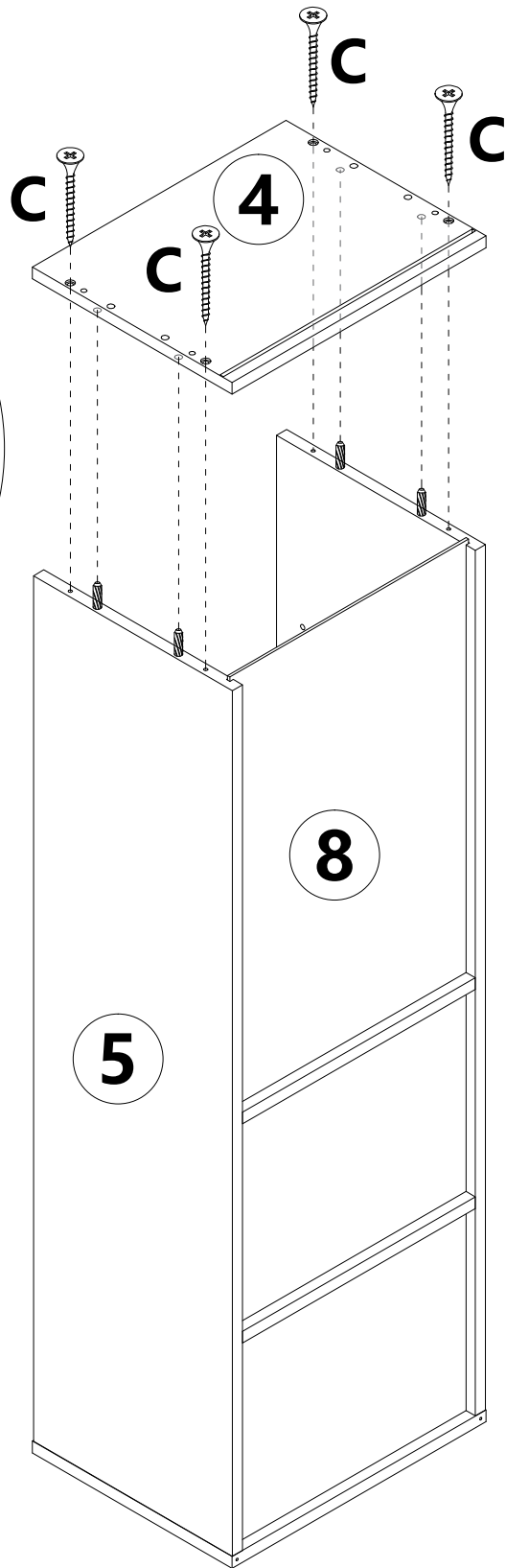
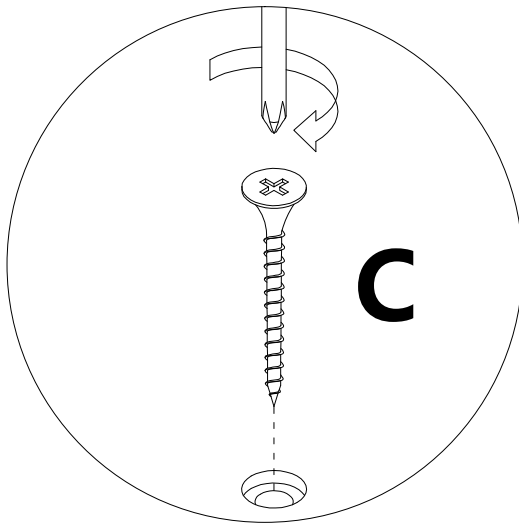
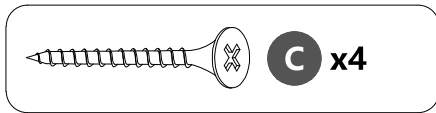

15

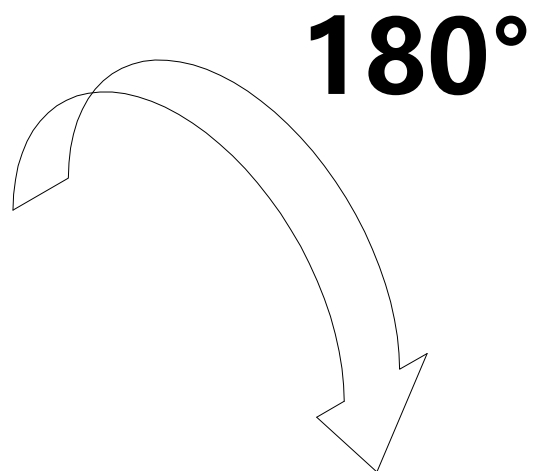
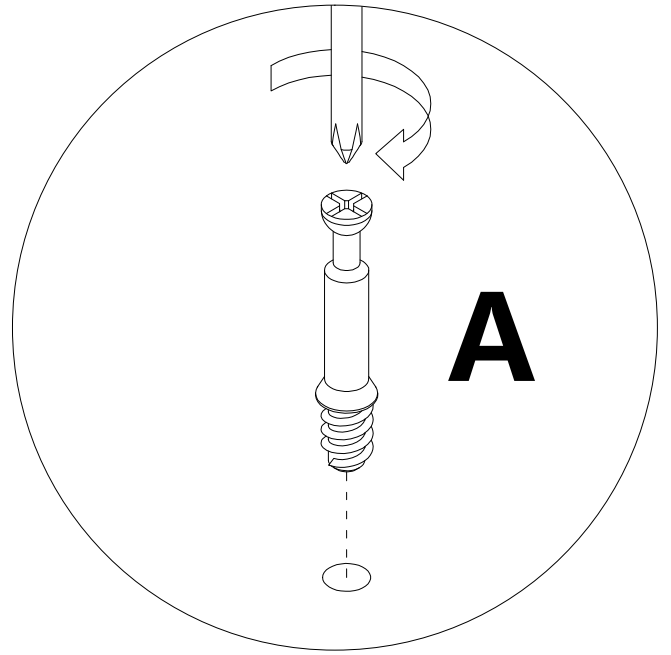
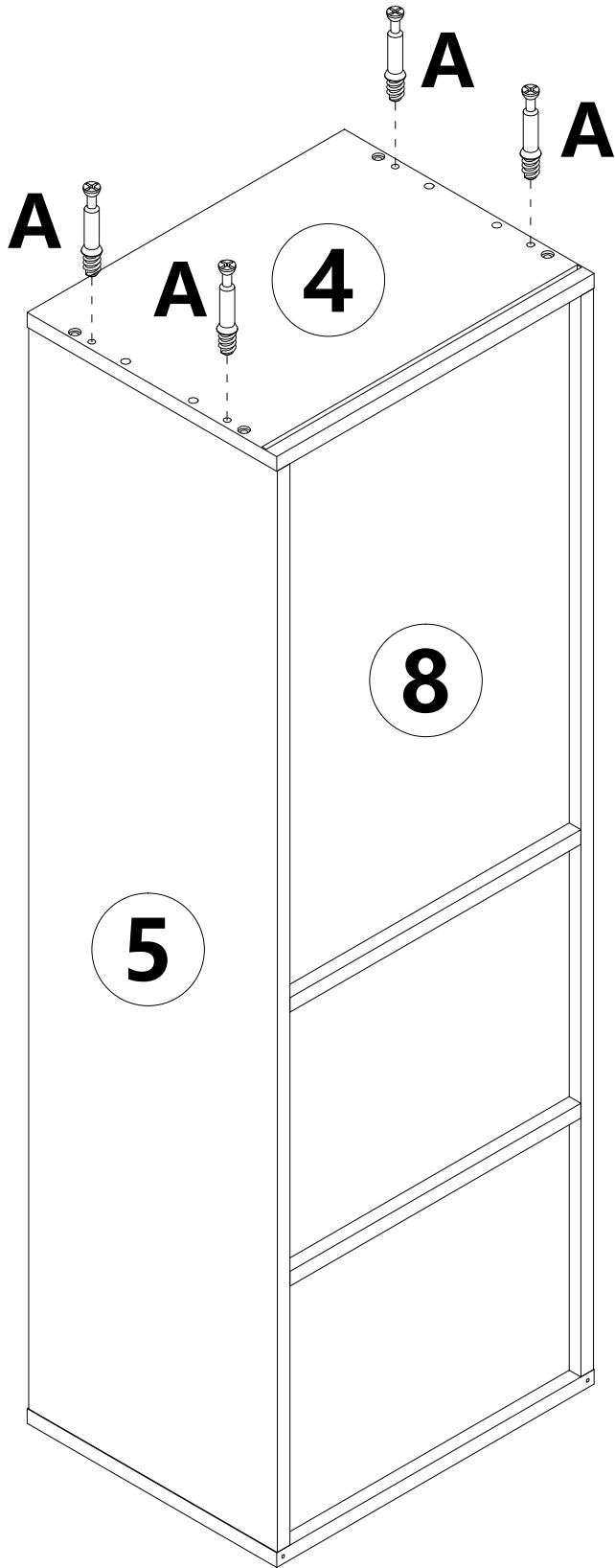
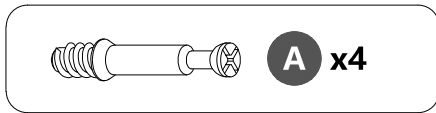

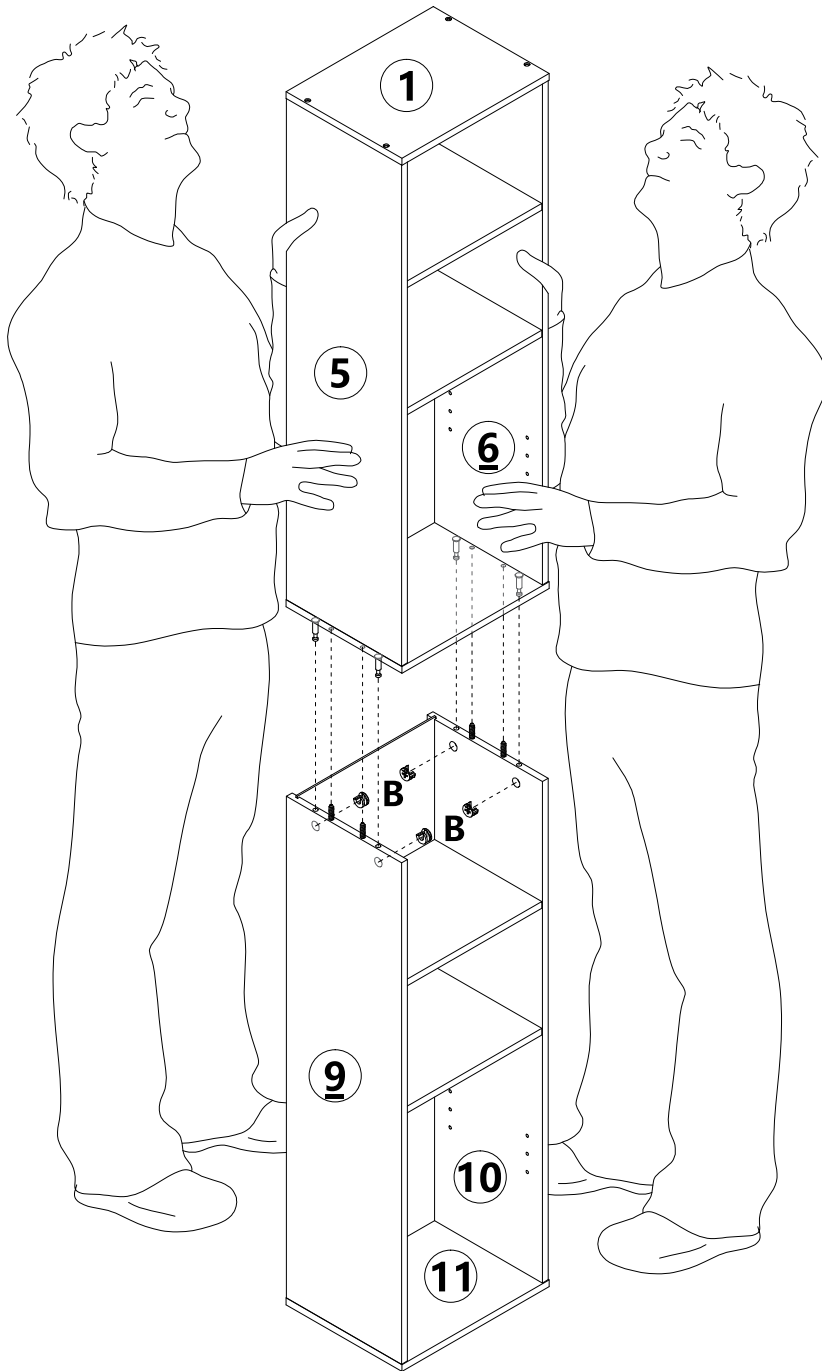
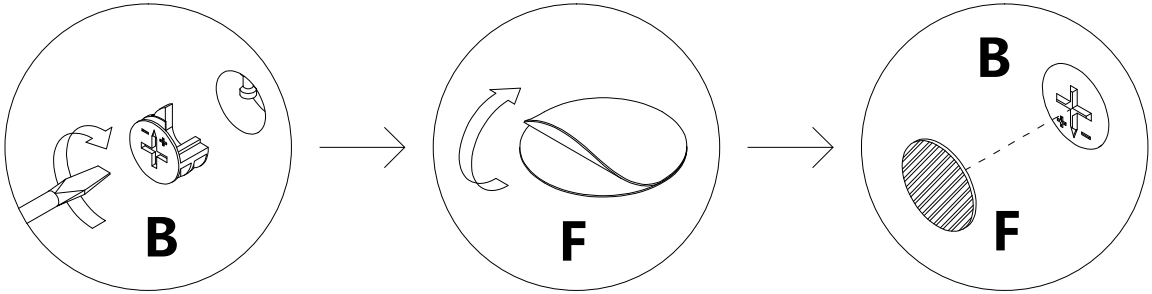

17

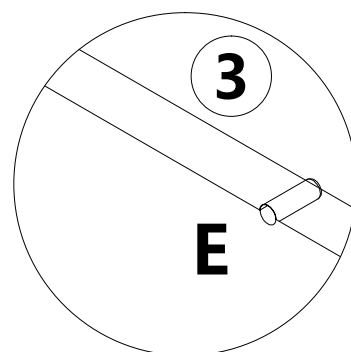
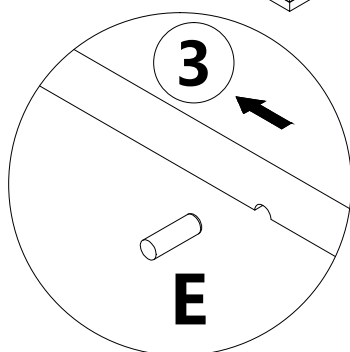
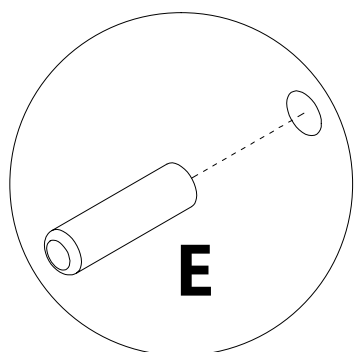
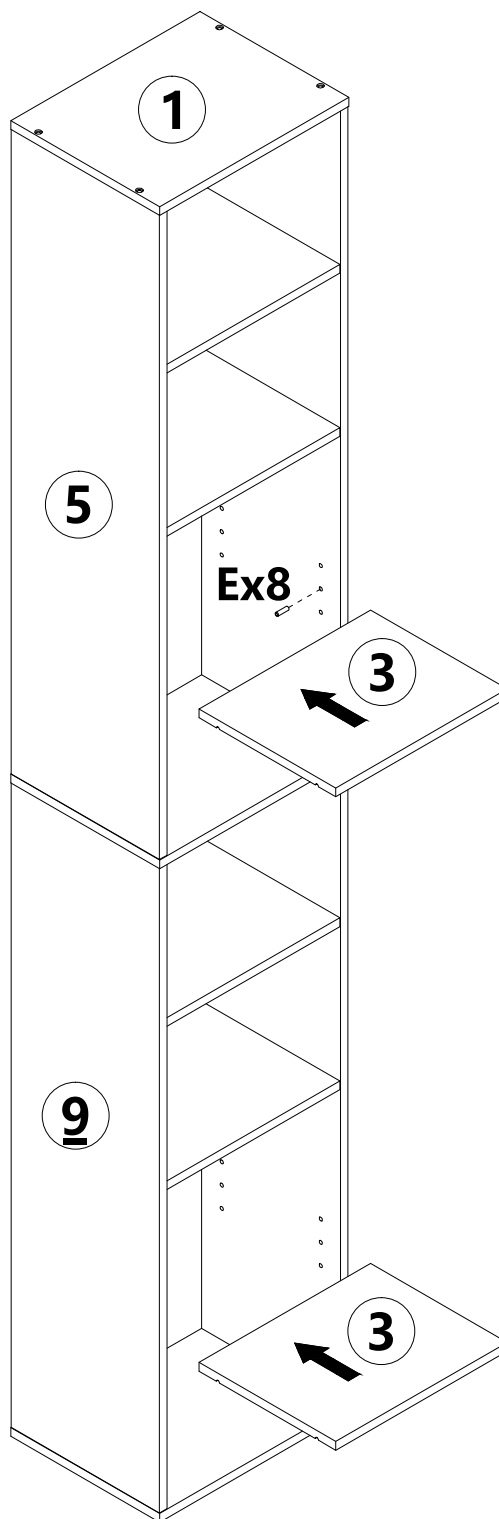
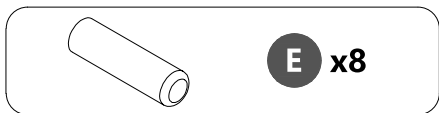

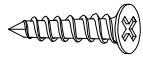

H x26



I x24



J x2

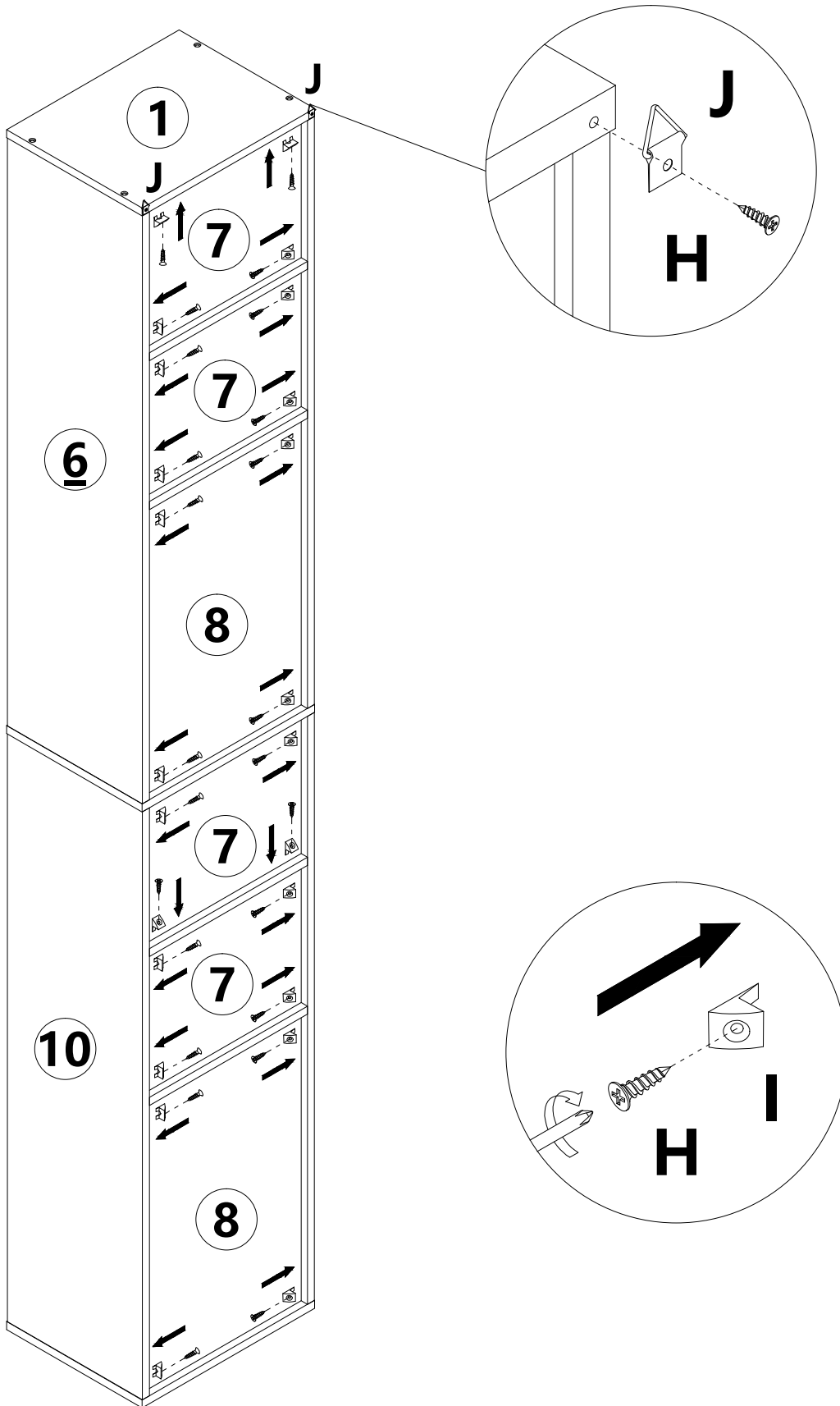

19



C x2



J x2

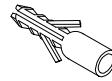

K x2

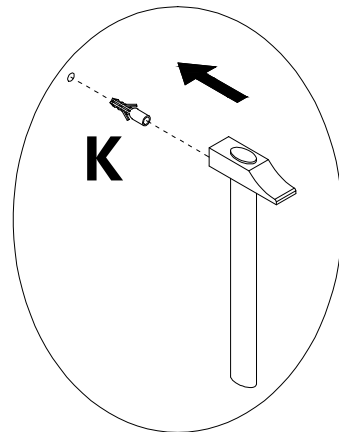
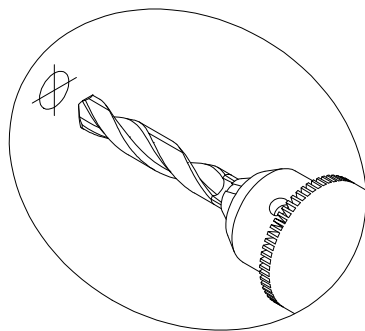
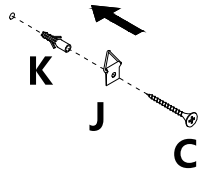
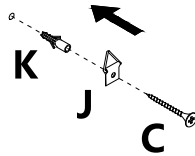
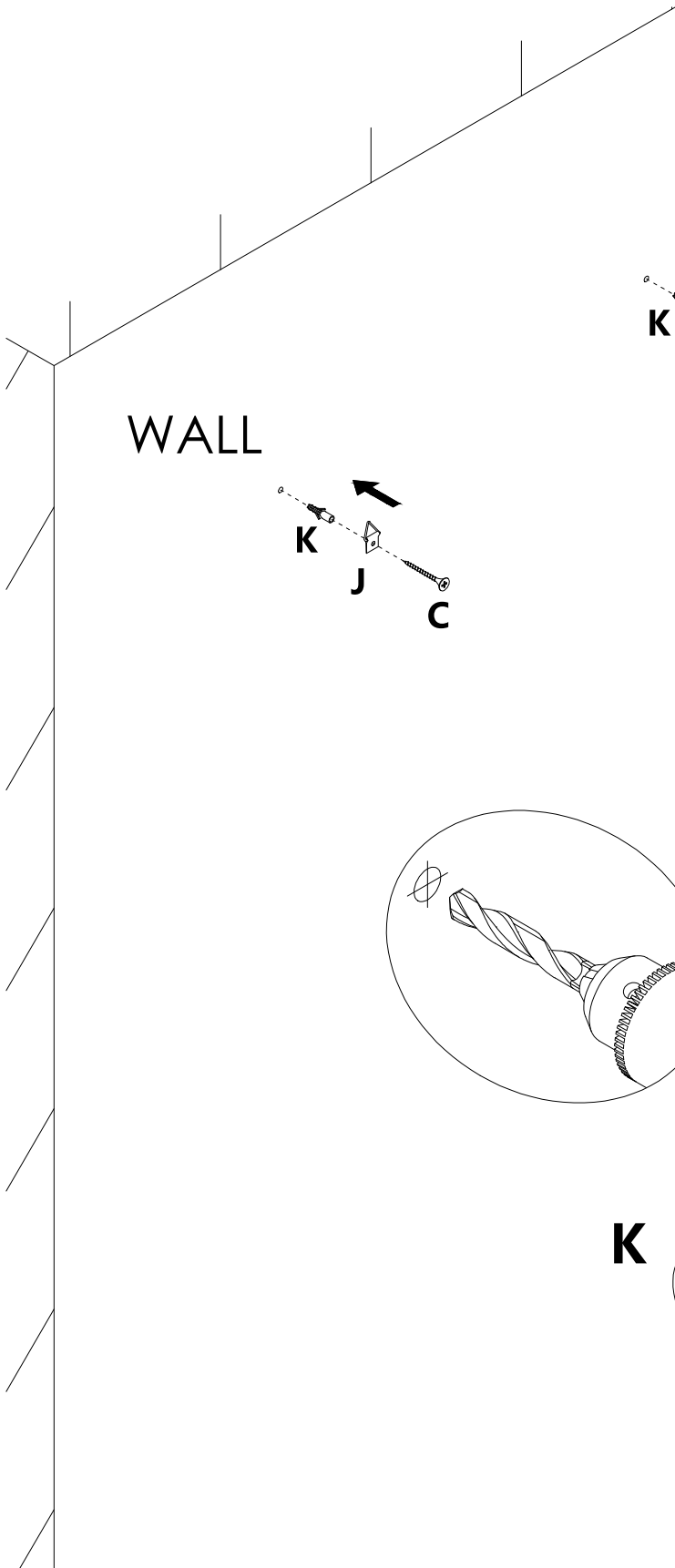

K

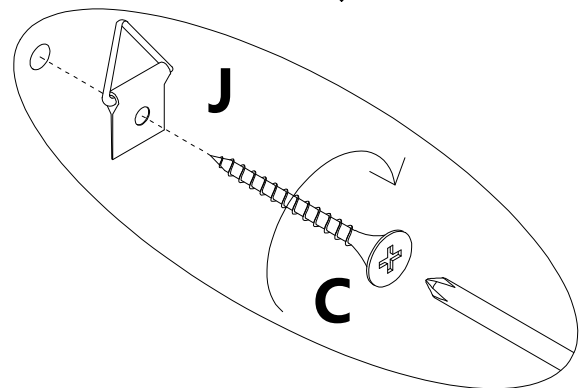

20

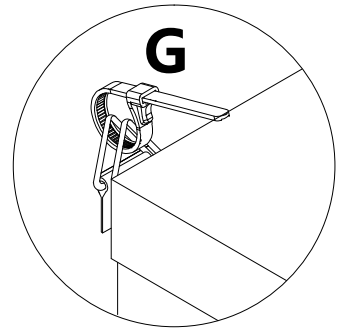
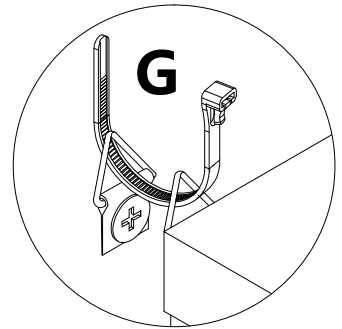
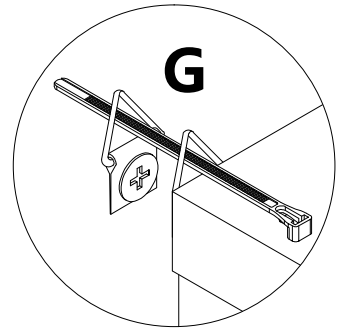
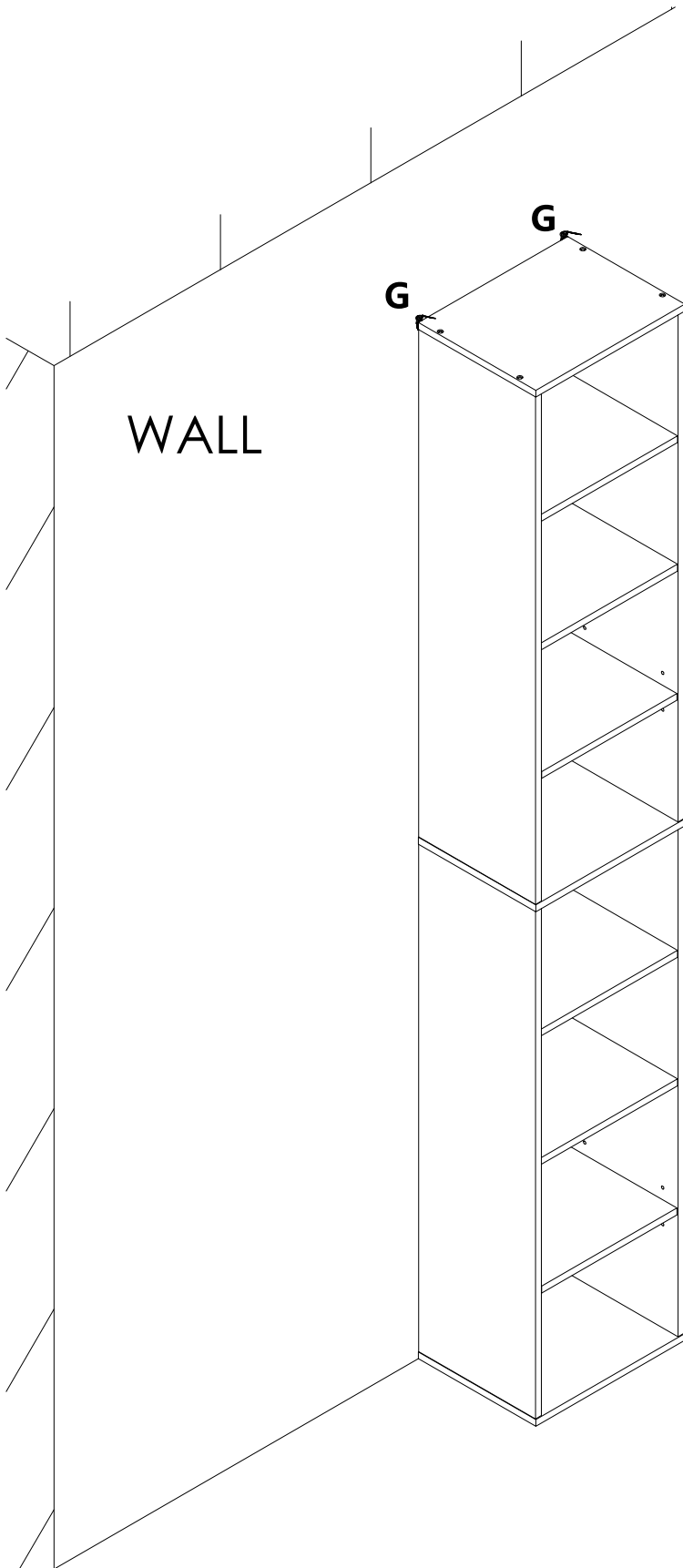
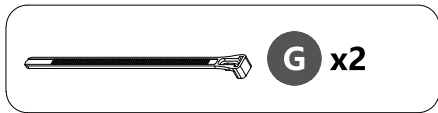

Guarantee and Service

- If you have any issues with your item please let us know! We will always do our best to come up with a solution that you will be happy with.
 - Please get in touch with our customer service team before returning the product.
 - And please do not throw the original box(es) if you have not finished assembling or confirmed no quality issues.
- * Length of return period:
- Items can be returned within 30 days of purchase.
 - In the meanwhile, everything you purchased from us comes with a one-year warranty.

Garantie et Service

- Si vous avez des problèmes avec votre article, veuillez nous en informer ! Nous ferons toujours de notre mieux pour trouver une solution qui vous satisfera.
 - Veuillez contacter notre service client avant de retourner le produit.
 - Et veuillez ne pas jeter la ou les boîtes d'origine tant que vous n'avez pas terminé l'assemblage ou confirmé l'absence de problèmes de qualité.
- * Durée de la période de retour :
- Les articles peuvent être retournés dans les 30 jours suivant l'achat.
 - De plus, tout ce que vous avez acheté chez nous est couvert par une garantie d'un an.

Garantie und Service

- Falls Sie Probleme mit Ihrem Artikel haben, lassen Sie es uns bitte wissen! Wir werden stets unser Bestes tun, um eine Lösung zu finden, mit der Sie zufrieden sind.
 - Bitte wenden Sie sich an unser Kundenservice-Team, bevor Sie das Produkt zurücksenden.
 - Und bitte werfen Sie die Originalverpackung(en) nicht weg, wenn Sie das Produkt noch nicht vollständig montiert haben oder noch keine Qualitätsprobleme ausgeschlossen sind.
- * Rückgabefrist:
- Artikel können innerhalb von 30 Tagen nach dem Kauf zurückgegeben werden.
 - Alle von Ihnen gekauften Produkte haben außerdem eine einjährige Garantie.

Garantía y Servicio

- Si tiene algún problema con su artículo, ¡háganoslo saber! Siempre haremos nuestro mejor esfuerzo para encontrar una solución que le satisfaga.
 - Póngase en contacto con nuestro equipo de atención al cliente antes de devolver el producto.
 - Y no tire la(s) caja(s) original(es) si no ha terminado de ensamblar o confirmado que no hay problemas de calidad.
- * Duración del período de devolución:
- Los artículos se pueden devolver dentro de los 30 días posteriores a la compra.
 - Además, todo lo que compre de nosotros viene con una garantía de un año.

Garanzia e Servizio

- Se hai problemi con il tuo articolo, faccelo sapere! Faremo sempre del nostro meglio per trovare una soluzione che ti soddisfi.
 - Ti preghiamo di contattare il nostro team di assistenza clienti prima di restituire il prodotto.
 - E ti preghiamo di non gettare la/le scatola/e originale/i se non hai finito di assemblare o confermato l'assenza di problemi di qualità.
- * Durata del periodo di restituzione:
- Gli articoli possono essere restituiti entro 30 giorni dall'acquisto.
 - Inoltre, tutti gli articoli acquistati da noi sono coperti da una garanzia di un anno.

保証とサービス

- 商品に問題がある場合は、お知らせください! お客様がご満足いただける解決策を見つけるために、最善を尽くします。
 - 製品を返品する前に、カスタマーサービスチームにご連絡ください。
 - 組み立てが完了していないか、品質に問題がないことを確認していない場合は、元の箱を捨てないでください。
- * 返品期間の長さ:
- 購入から30日以内であれば、商品の返品が可能です。
 - さらに、当社からご購入いただいたすべての商品には1年間の保証が付いています。



US:service@kmcglobe-us.com
FR:service@kmcglobe-fr.com
JP:service@kmcglobe-jp.com

UK:service@kmcglobe-uk.com
ES:service@kmcglobe-es.com

DE:service@kmcglobe-de.com
IT:service@kmcglobe-it.com



(+1) 559-354-1889(ONLY US)