

Desk

IMPORTANT

Carefully remove all the parts from the carton and place them individually on a soft cloth to prevent scratches or other damage.

Carefully and strictly follow these assembly instructions to ensure a completed product as designed.

Do not use power tools above 8 volts to assemble.

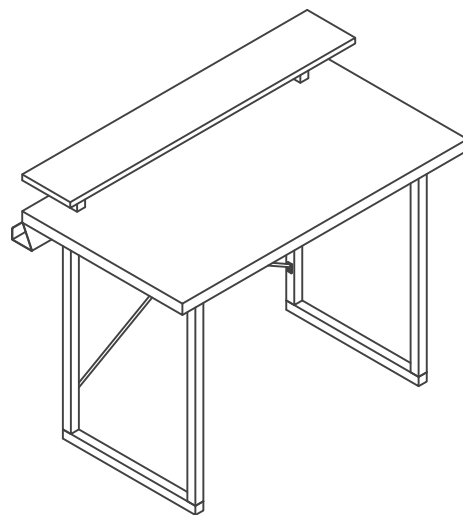

Part List

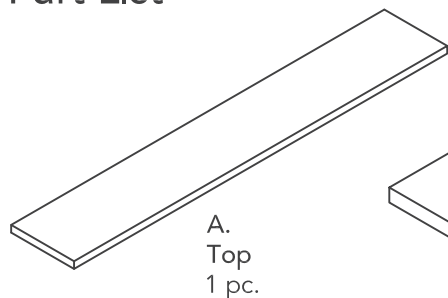

A.
Top
1 pc.

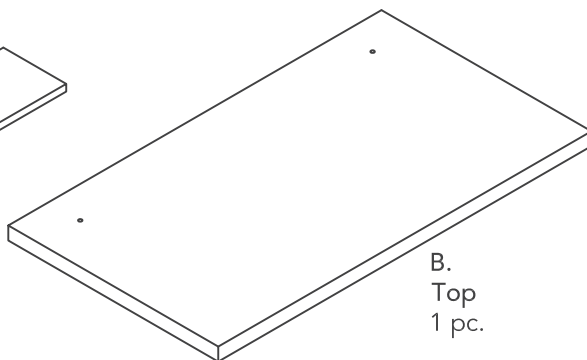

B.
Top
1 pc.

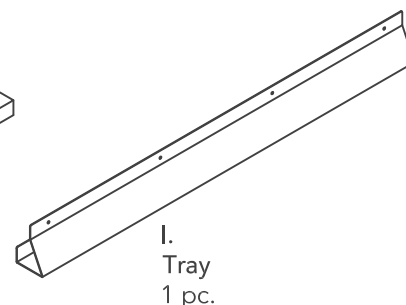

I.
Tray
1 pc.

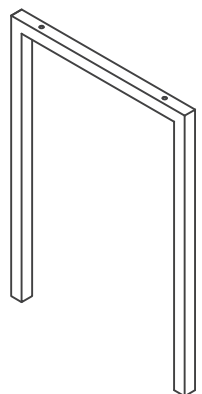

C.
Side Frame
1 pc.

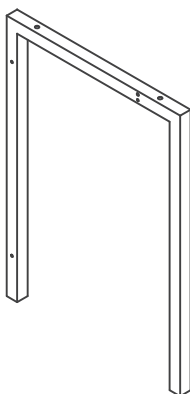

D.
Side Frame
1 pc.



E.
Upright
2 pcs.



H.
Rail
2 pcs.

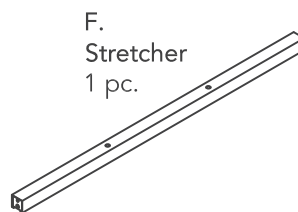

F.
Stretcher
1 pc.



G.
Stretcher
2 pcs.

Hardware List



M6x45
Head Cap Bolt (long)
10 pcs. (+1 extra)



M6x30
Head Cap Bolt (medium)
2 pcs. (+1 extra)



M6x15
Head Cap Bolt (short)
10 pcs. (+1 extra)



M3x19
3/4" Flat Head Screw
4 pcs. (+1 extra)



Pin
2 pcs. (+1 extra)



Flat Washer
2 pcs. (+1 extra)



Spring Washer
2 pcs. (+1 extra)

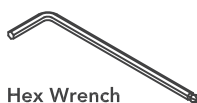

Hex Wrench
1 pc.



Small Hex Wrench
1 pc.

Tool(s) required for assembly: Phillips screwdriver, Level

Assembly Instructions 2/5

IMPORTANT

- Use a soft cloth between these parts and the floor.
- Do not use power tools above 8 volts to assemble.
- Do not tighten all the screws until each part is properly assembled.
- The unit must be level to work properly. Use the included adjustable levelers to level.
- Keep Hex Wrench as the bolts may need to be tightened in the future.

STEP 1

Attach Uprights (E) to Top (A) with Head Cap Bolts (short).

Tighten Head Cap Bolts with Hex Wrench. (See Figure 1)

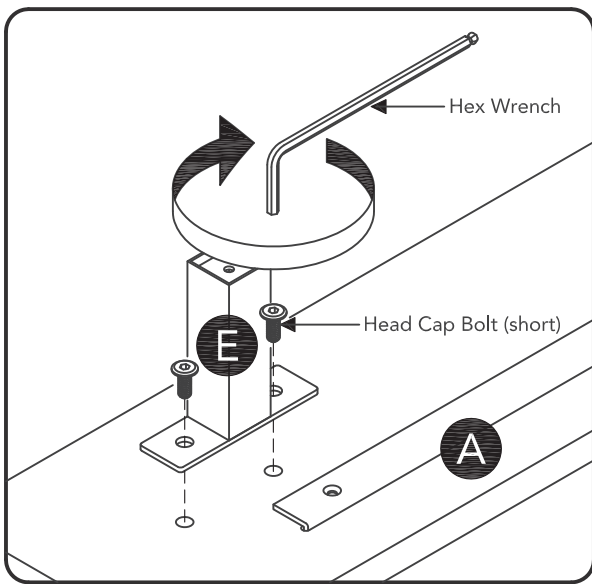
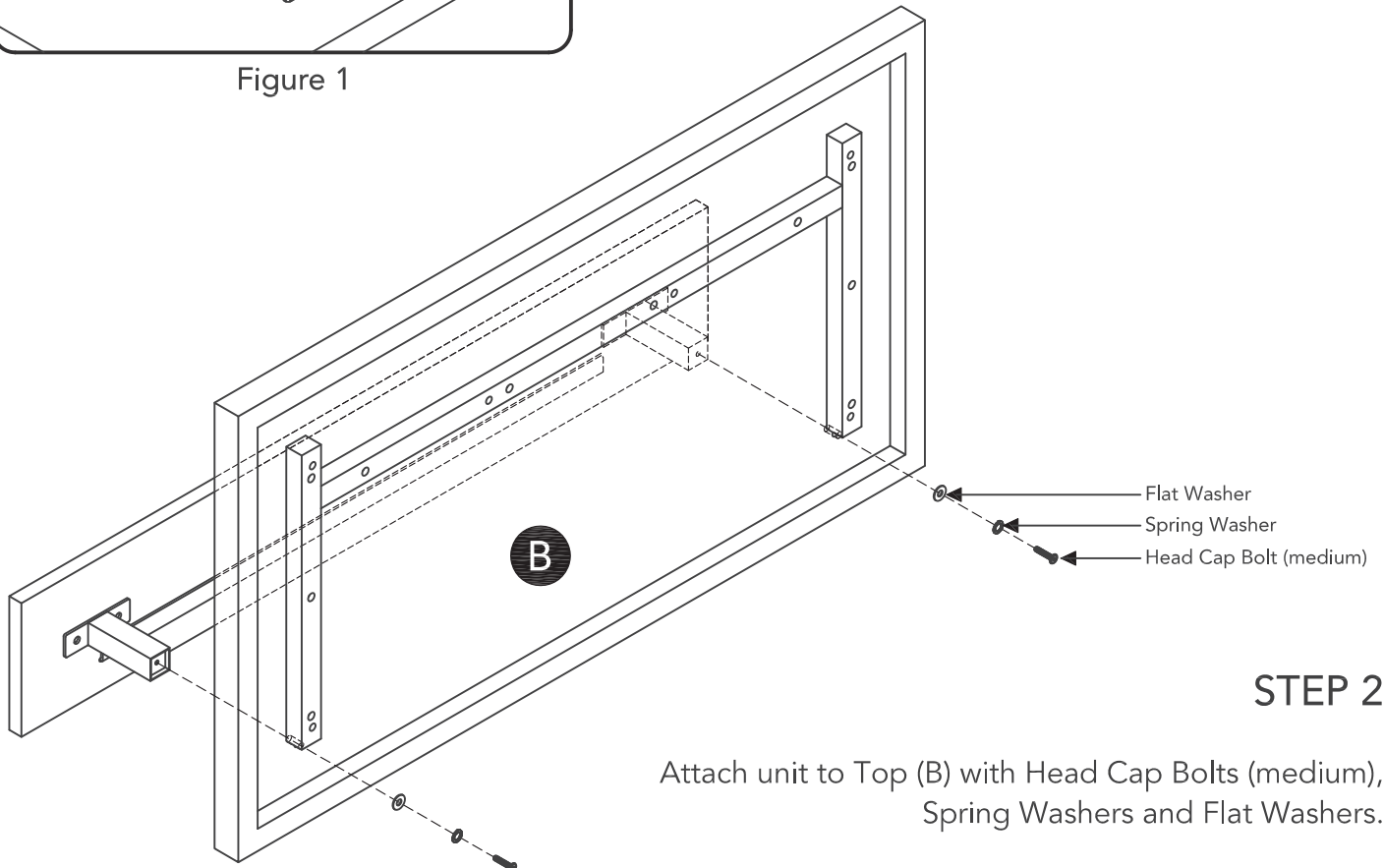
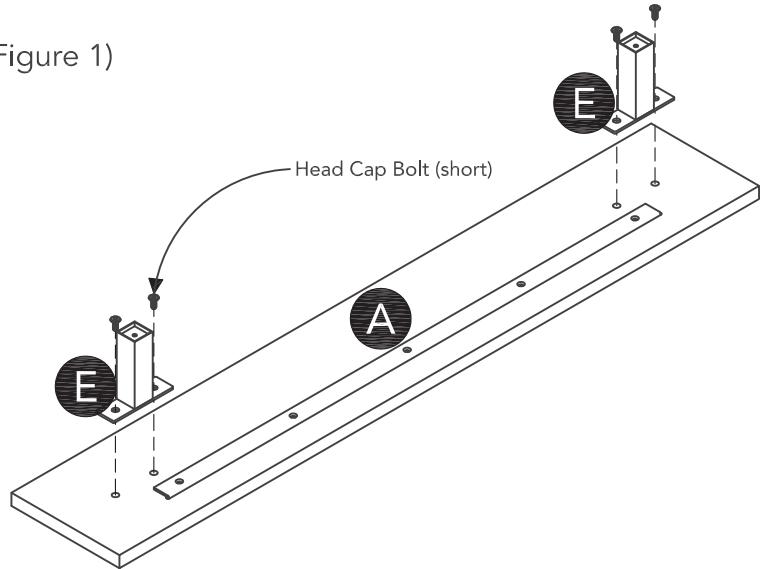

Figure 1



STEP 2

Attach unit to Top (B) with Head Cap Bolts (medium), Spring Washers and Flat Washers.

Tighten Head Cap Bolts with Hex Wrench.

STEP 3

Attach Rails (H) to Side Frames (C) and (D) with Head Cap Bolts (long).

Tighten Head Cap Bolts with Hex Wrench.

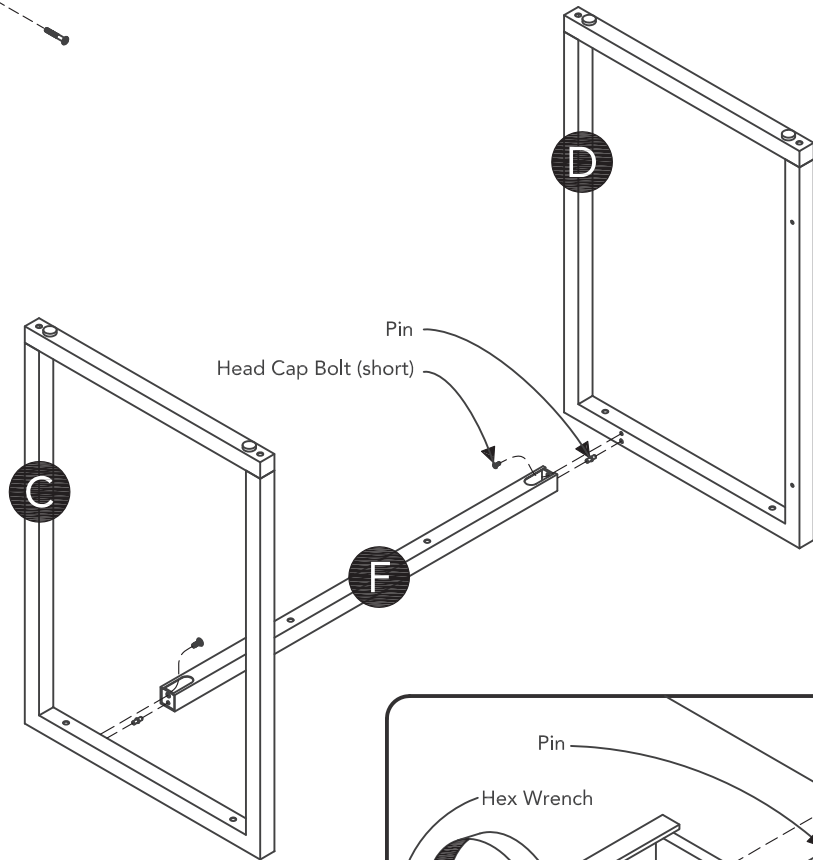
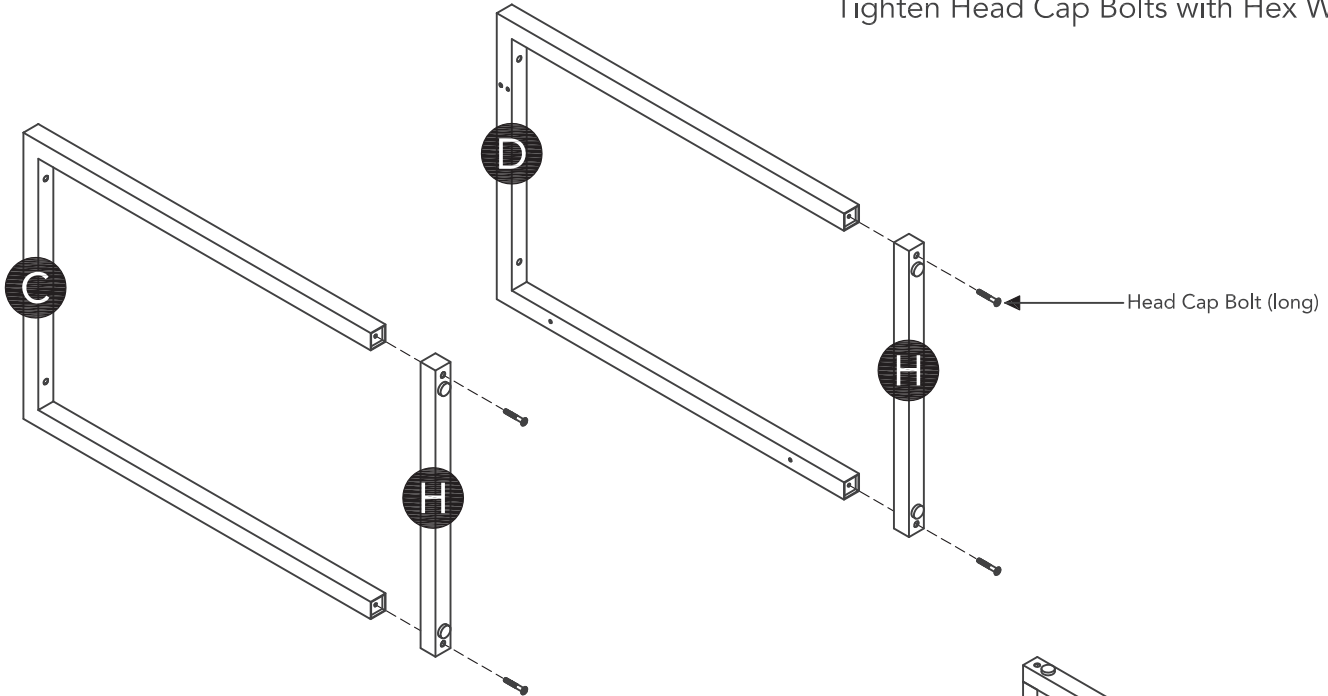

STEP 4

Attach Stretcher (F) to Side Frames (C) and (D) with Pins and Head Cap Bolts (short).

Tighten Head Cap Bolts with Hex Wrench.
(See Figure 2)

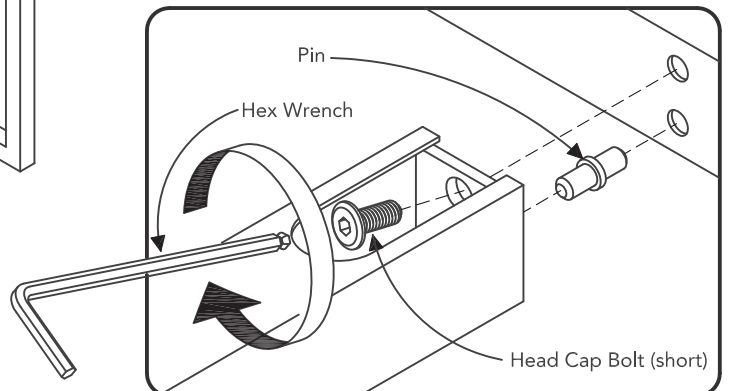

Figure 2

STEP 5

Attach Stretchers (G) to unit with Head Cap Bolts (short).

Tighten Head Cap Bolts with Hex Wrench.
(See Figure 3)

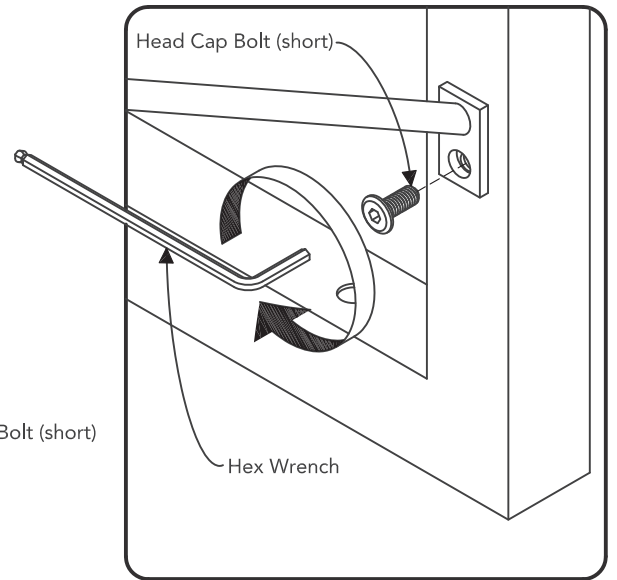
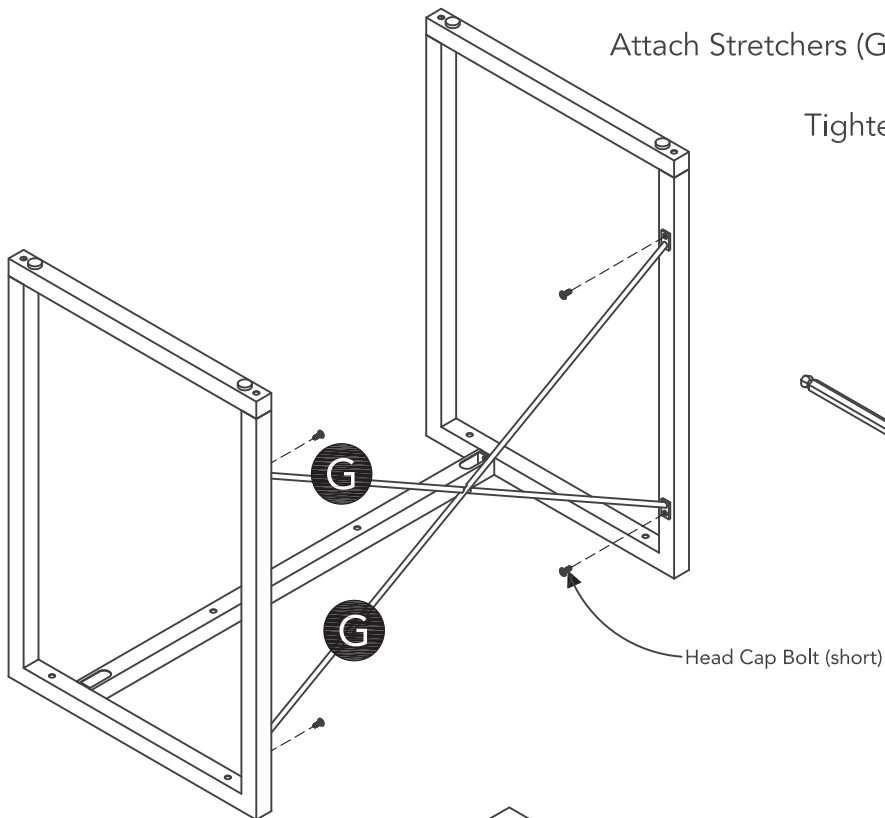
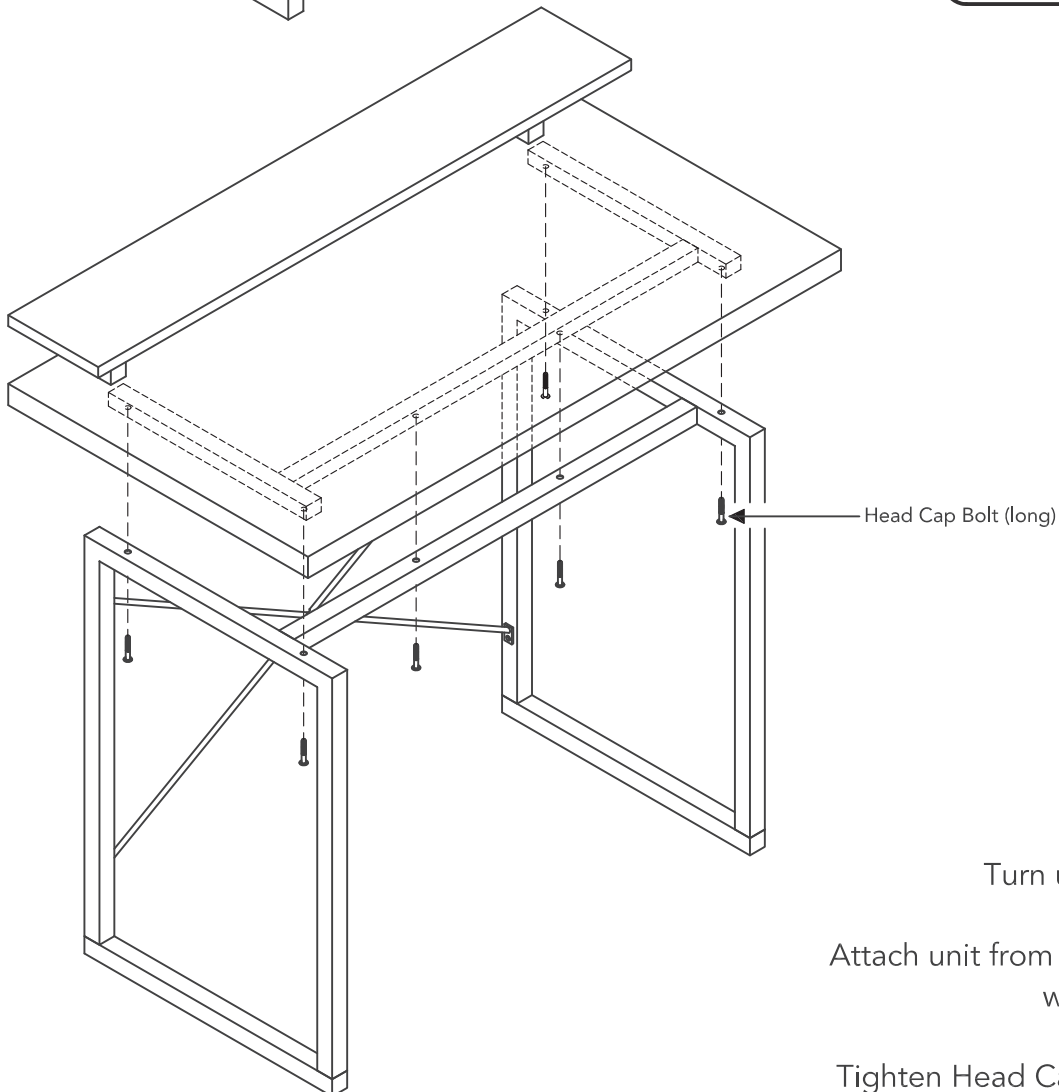

Figure 3



STEP 6

Turn unit to its upright position.

Attach unit from Step 2 to unit from Step 5
with Head Cap Bolts (long).

Tighten Head Cap Bolts with Hex Wrench.

STEP 7

Attach Tray (I) to unit with 3/4" Flat Head Screws.

Level unit by adjusting the adjustable levelers on bottom of unit. (See Figure 4)

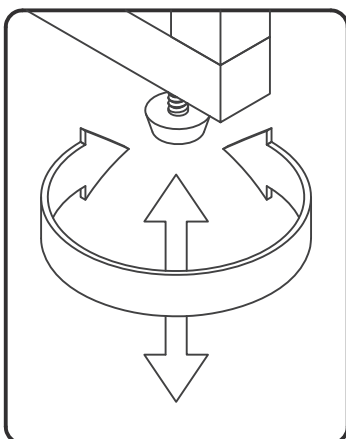
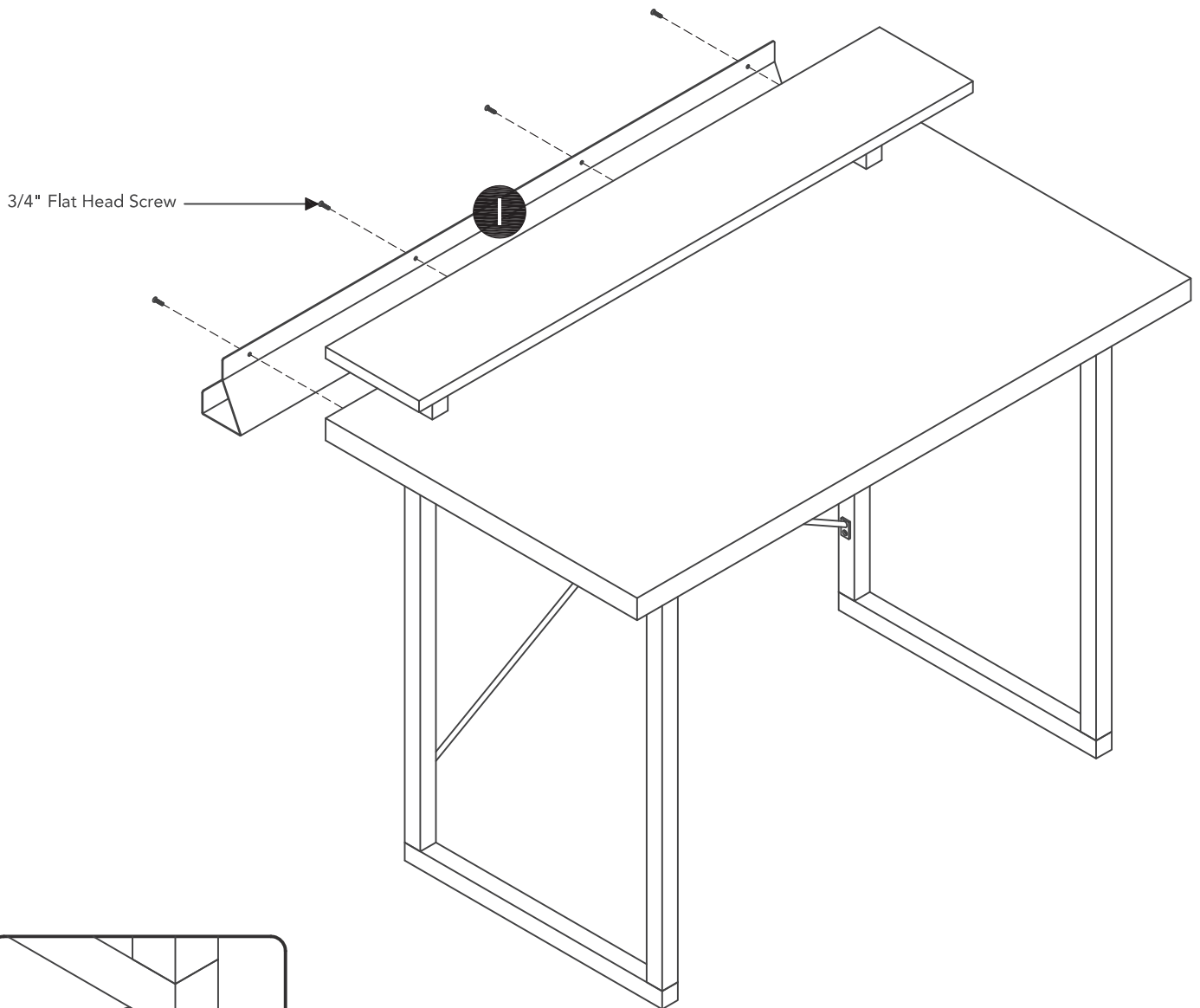

Figure 4

CARE INSTRUCTIONS

NEVER

allow liquids to remain on furniture.
Absorption causes parts to warp
and split and finishes to delaminate.

NEVER

use glass cleaners on
finished furniture. Ammonia
chemically attacks the finish.



Do not use power tools
above 8 volts to assemble.

**PREVENT
CRACKING**

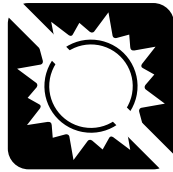

Do not place
in direct sunlight.

**PREVENT
FADING**



Do not write
directly on surface.

**PREVENT
MARKING**



Do not place hot
objects on surface.

**PREVENT
FINISH DAMAGE**

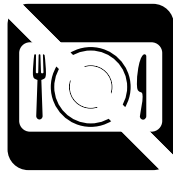

Do not use rubber
based placemats.

**PREVENT
DISCOLORING**



Do not use commercial
waxes and polishes.

**PREVENT
YELLOWING**

CLEAN

with a soft cloth moistened
in lukewarm soap and water.
Buff with a dry clean cloth.

