

# ASSEMBLY INSTRUCTION

ITEM:D2005-CH (2PCS/Carton)

## STEP:1

Attach the two Front Legs(A) to the Seat Frame(B) using 4pcs of FHG bolt set.

Caution: Tighten screws **HALFWAY** to allow for later adjustments.

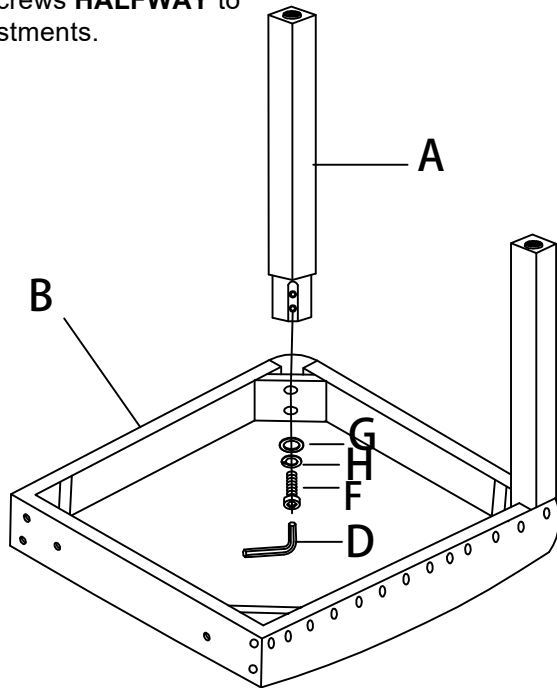

## PARTS LIST

NO.	DESCRIPTION	SKETCH	QTY
A	FRONT LEGS		4PCS
B	SEAT FRAME		2PC
C	CHAIR BACK		2PC

## HARDWARE LIST

NO.	DESCRIPTION	SKETCH	QTY
D	WRENCH 5MM		2PC
E	BOLT $\square$ 5/16" * 3-1/2"		8PCS
F	BOLT $\square$ 5/16" * 2"		12PCS
G	LOCK WASHER 5/16" * 22MM		20PCS
H	FLAT WASHER 5/16"		20PCS

## STEP:2

Attach the Chair Back(C) to the Seat Frame(B).

- ① Partially tighten the FHG bolt set in 2 center screw hole for positioning.
- ② Then partially tighten the EHG bolt set in the 4 corner holes.

Caution: Tighten screws **HALFWAY** to allow for later adjustments.

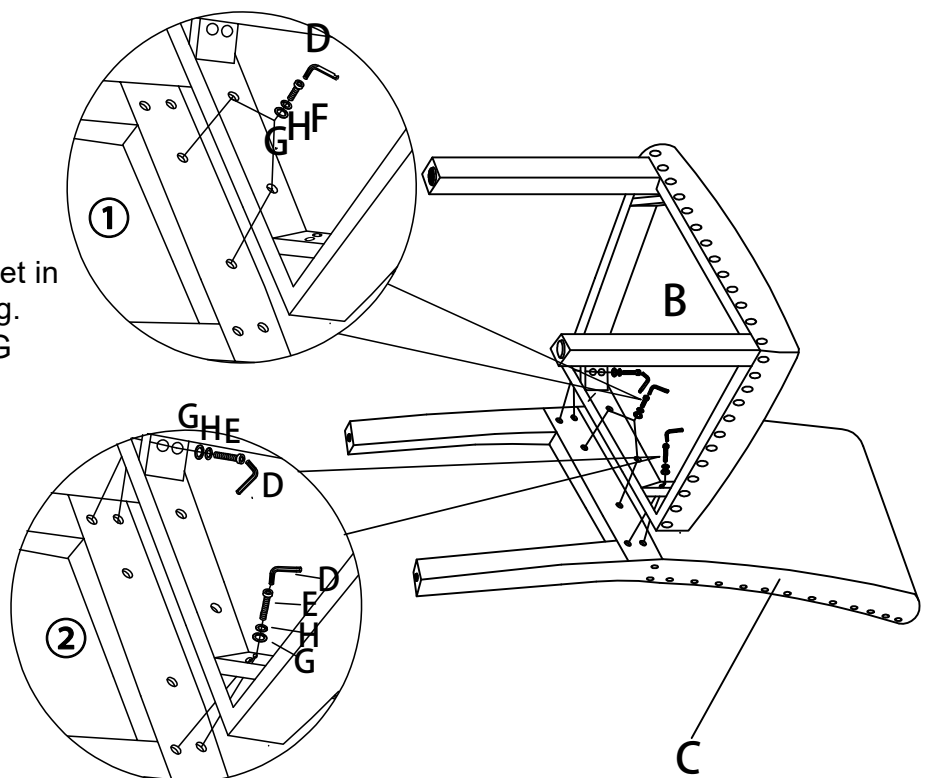

MADE IN VIETNAM

# ASSEMBLY INSTRUCTION

ITEM:D2005-CH (2PCS/Carton)

## STEP:3

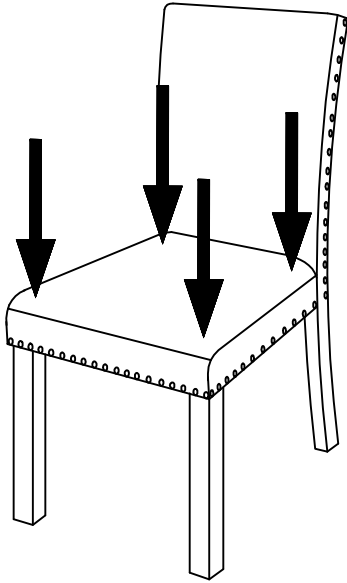

Place the chair upright on a flat and hard surface, press down on all four corners of the seat until it sits evenly.

## STEP:4

Once the chair is level and stable, carefully tighten all screws securely.

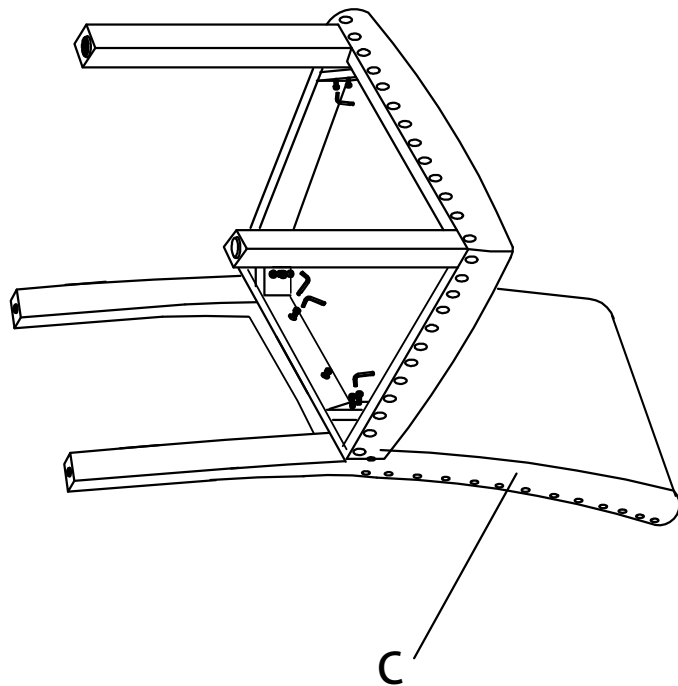

COMPLETE

MADE IN VIETNAM