

# Lift Top Coffee Table

## Instruction Manual

# Mesa de café elevable

## Manual de instrucciones

# Table basse relevable

## Manuel d'Instruction

T-LIFT-001

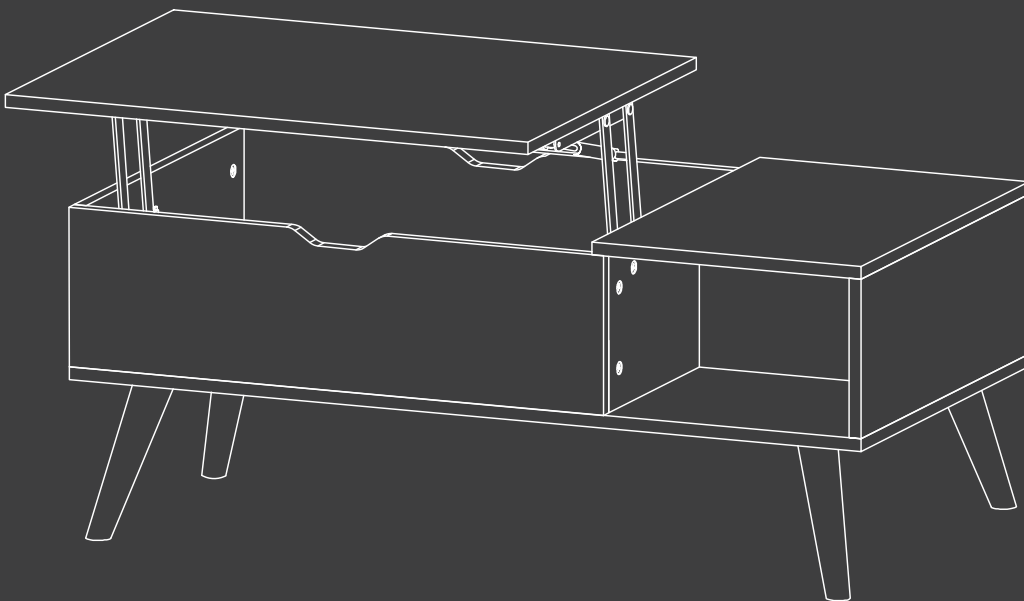

✉ [HJ-Customer-Service@outlook.com](mailto:HJ-Customer-Service@outlook.com)

☎ 6269443420 | 6267435564

EST 9:00AM--17:00PM

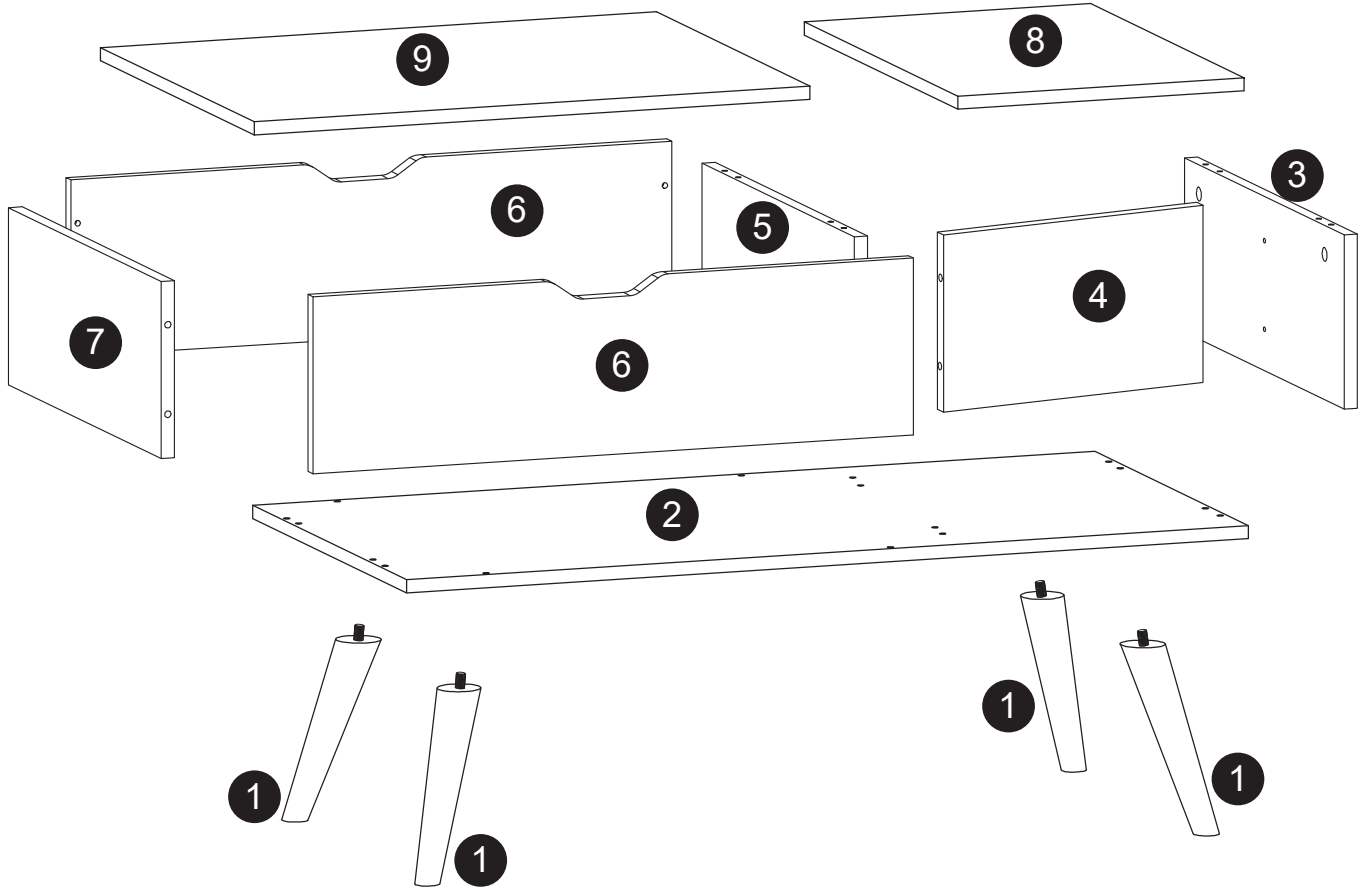

1 X4

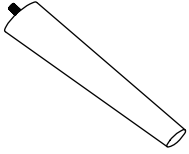

2 X1

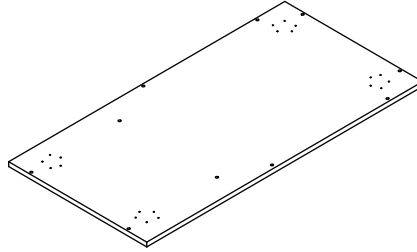

3 X1

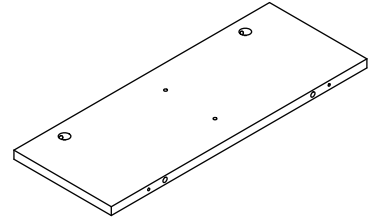

4 X1

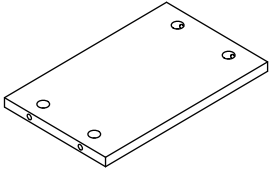

5 X1

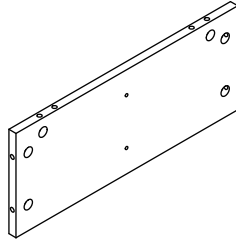

6 X2

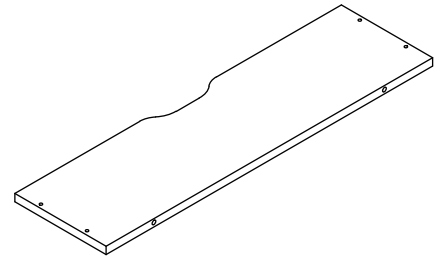

7 X1

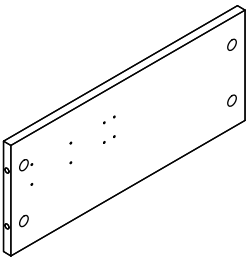

8 X1

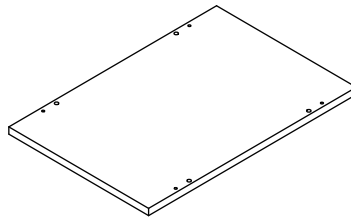

9 X1

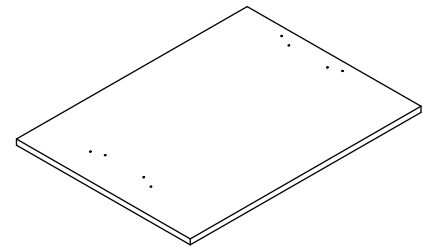

**A** X16



**B** X10



**C** X16



**D** X1

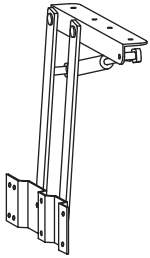

**E** X1

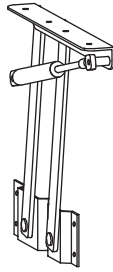

**F** X16

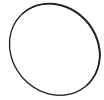

**G** X4



**H** X44

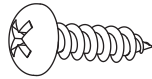

**I** X10



**J** X1

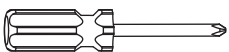

M4

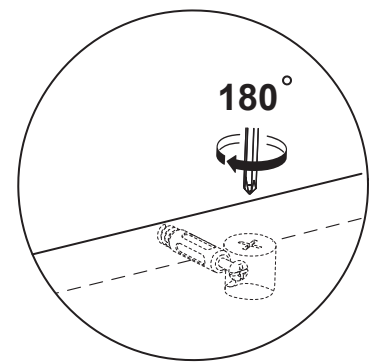
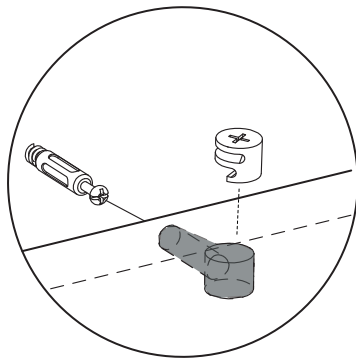
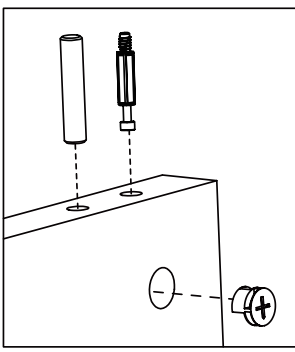

- EN: **NOTE:** 1. As shown, make sure each part is in the correct position.  
2. Align the slot of the cam lock with the cam bolt, then turn the cam lock clockwise to lock it.
- ES: **NOTA:** 1. Como se muestra, asegúrese de que cada pieza esté colocada en la posición correcta.  
2. Alinee la ranura de la excéntrica con el perno de excéntrica y, a continuación, gírela en sentido horario para bloquearla.
- FR: **REMARQUE :** 1. Comme indiqué, assurez-vous que chaque pièce est à la bonne position.  
2. Alignez la fente du verrou à came avec le boulon à came, puis tournez le verrou à came dans le sens des aiguilles d'une montre pour le verrouiller.

## Step 1

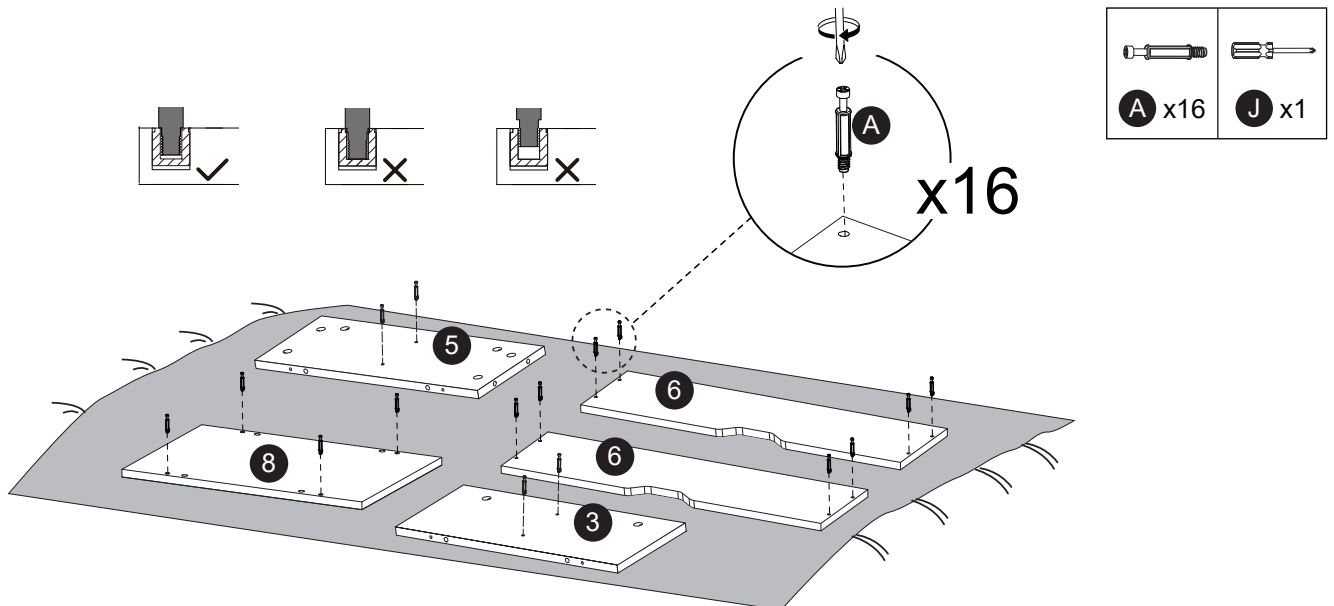

- EN: **NOTE:** 1. Place a blanket under the panels to prevent scratches or damage.  
2. Do not over-tighten or under-tighten the cam bolt (A).
- ES: **NOTA:** 1. Coloque una manta debajo de los paneles para evitar arañazos o daños.  
2. No apriete en exceso ni deje flojo el perno excéntrico (A).
- FR: **REMARQUE :** 1. Placez une couverture sous les panneaux pour éviter les rayures ou les dommages.  
2. Ne pas trop serrer ni trop desserrer le boulon à came (A).

## Step 2

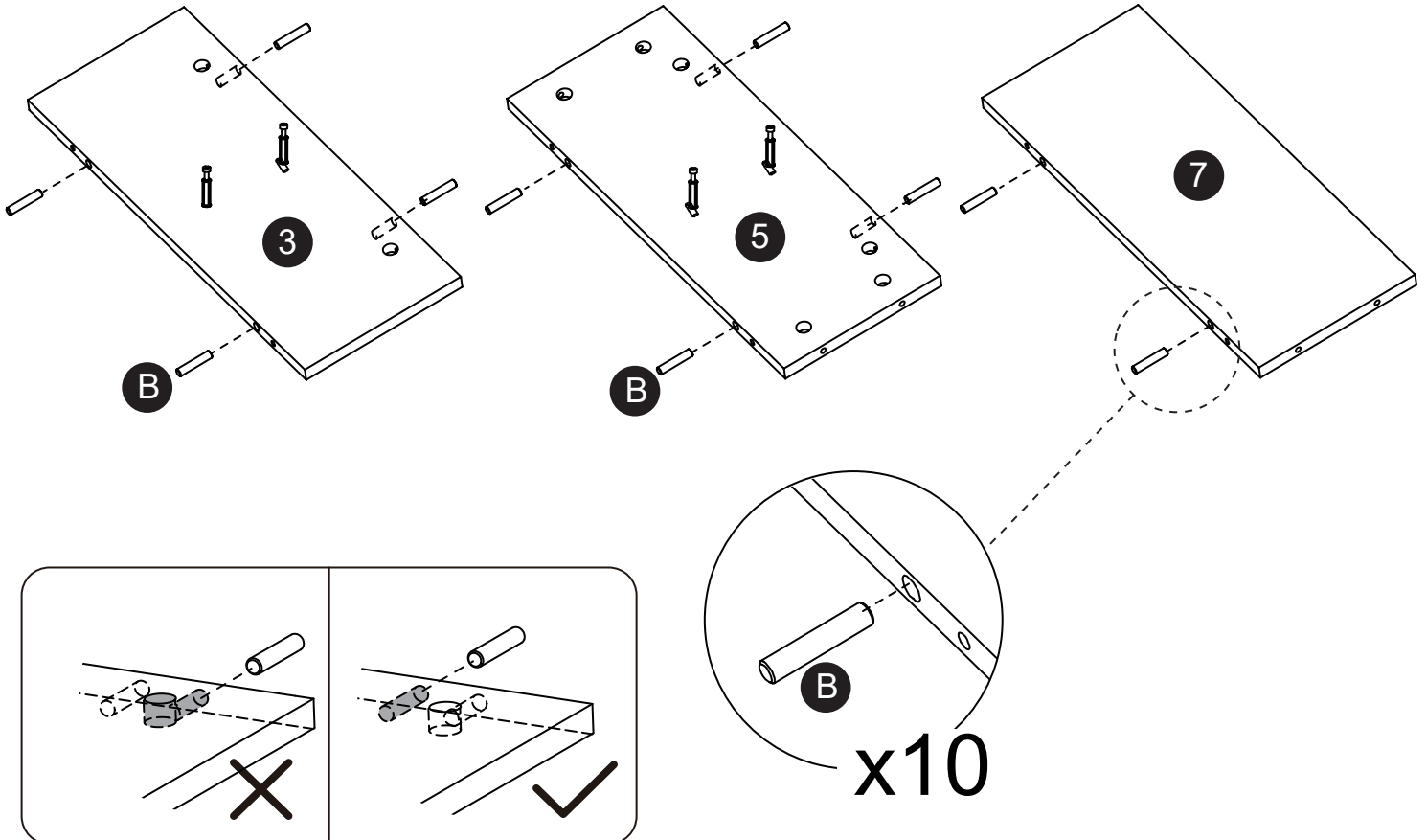
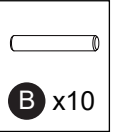





EN: **NOTE:** Insert wood dowels **B** into the holes closer to the center of the panel, not the edge holes.

ES: **NOTA:** Inserte los tacos de madera **B** en los orificios más cercanos al centro del panel, y no en los orificios de los bordes.

FR: **REMARQUE :** Insérez les chevilles en bois **B** dans les trous plus proches du centre du panneau, pas dans les trous de bord.

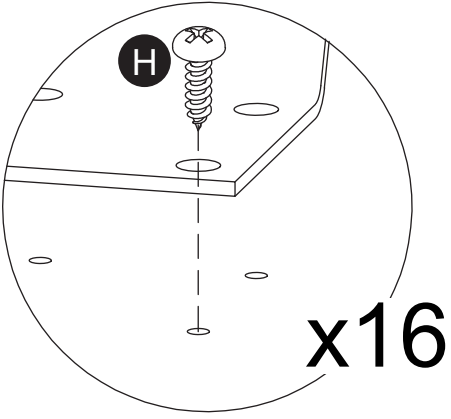
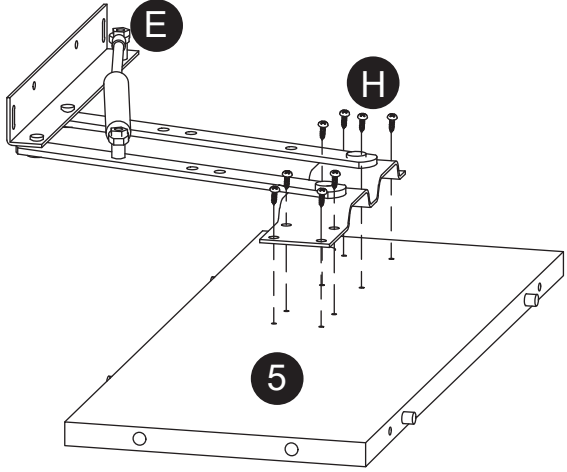
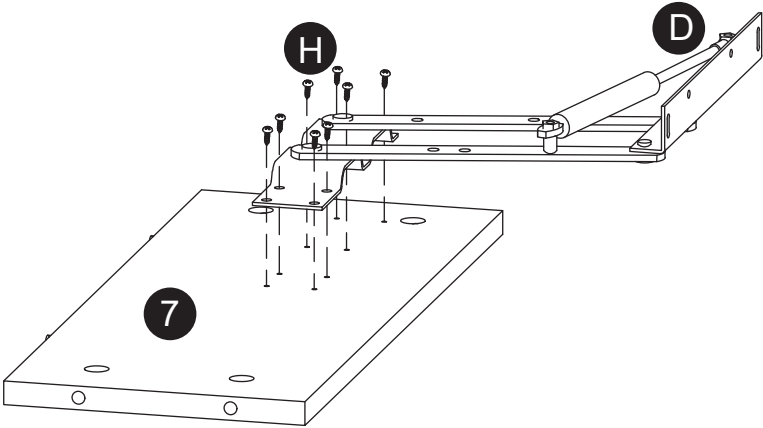

# Step 3

			
<b>D</b> x1	<b>E</b> x1	<b>H</b> x16	<b>J</b> x1





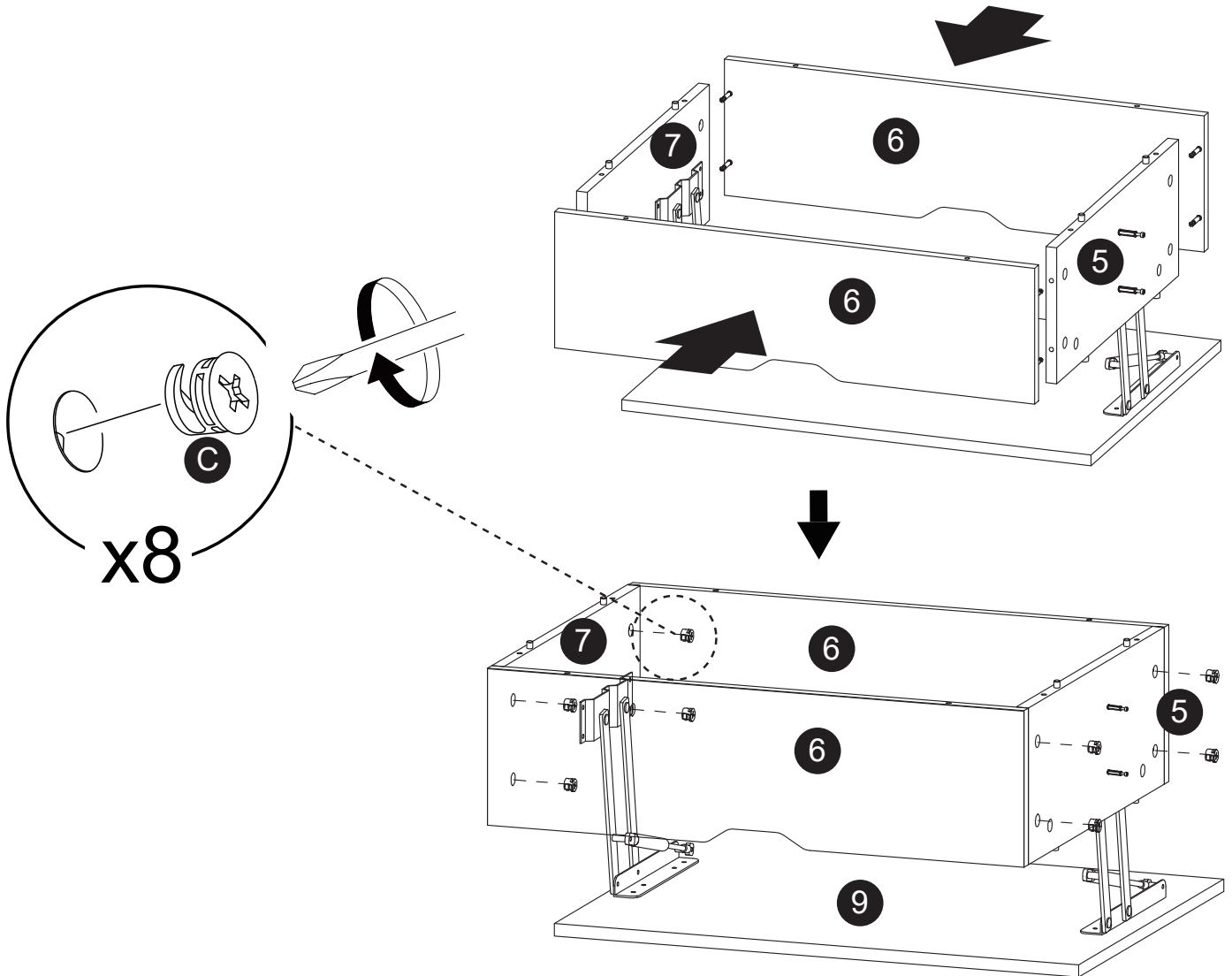

# Step 5

	
<b>C</b> x8	<b>J</b> x1



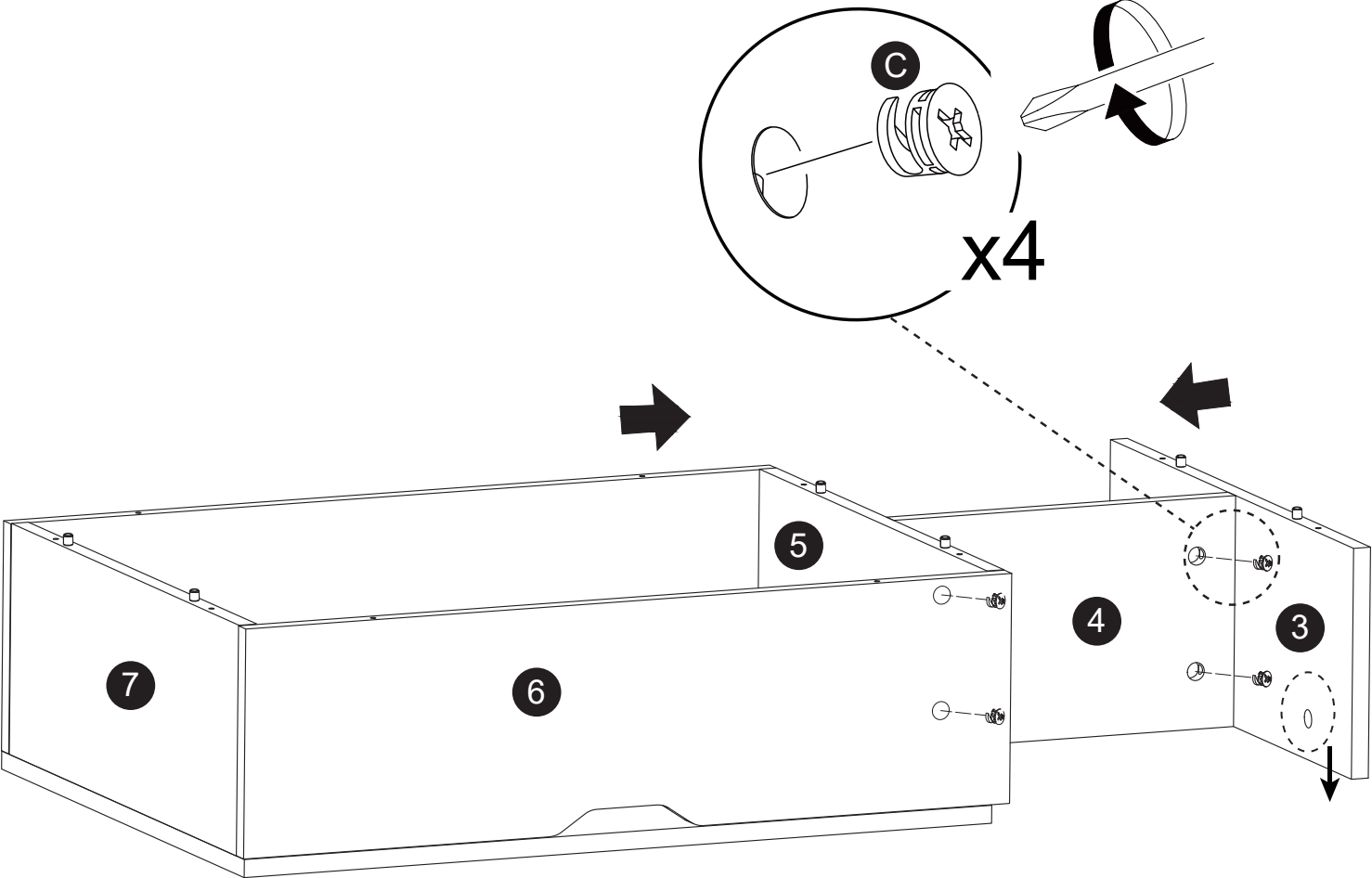

# Step 6

 <b>C</b> x4	 <b>J</b> x1
--	--



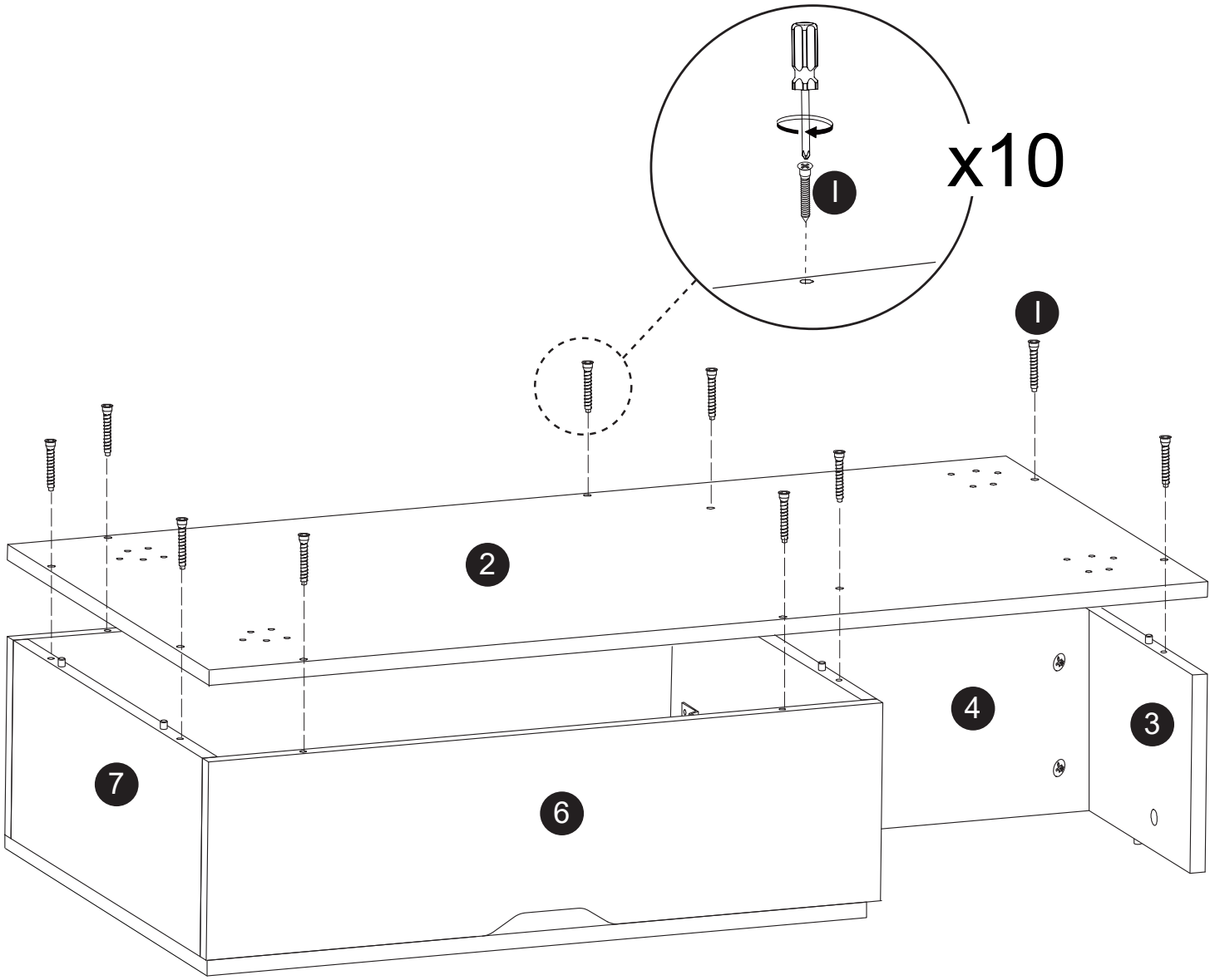

# Step 7

	
<b>I</b> x10	<b>J</b> x1



# Step 8

		
<b>G</b> x4	<b>H</b> x20	<b>J</b> x1

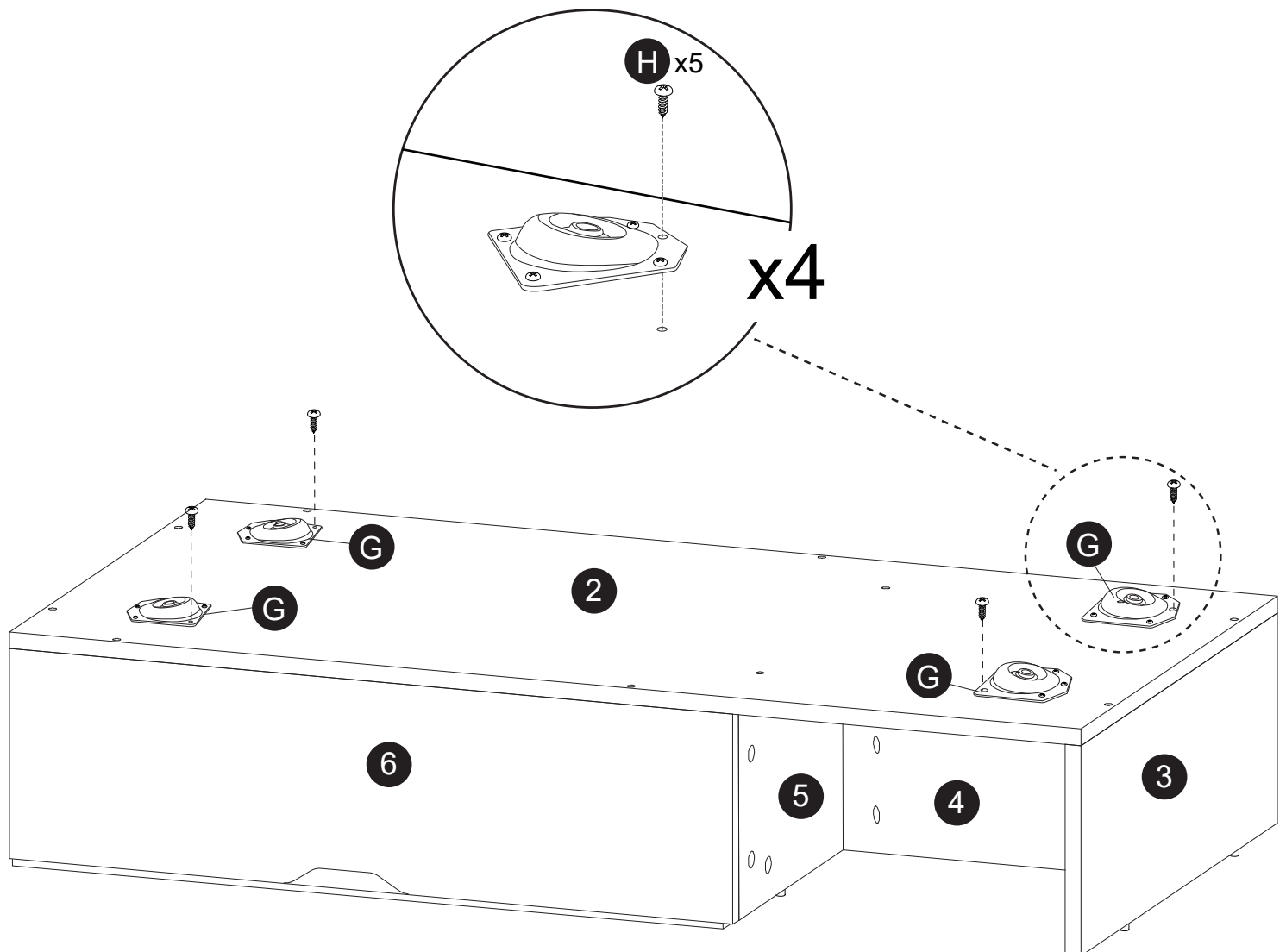

EN:  Parts **G** must be placed in the correct direction and position.

ES:  Las piezas **G** deben colocarse en la dirección y posición correctas.

FR:  Les pièces **G** doivent être placées dans le bon sens et à la bonne position.

# Step 9

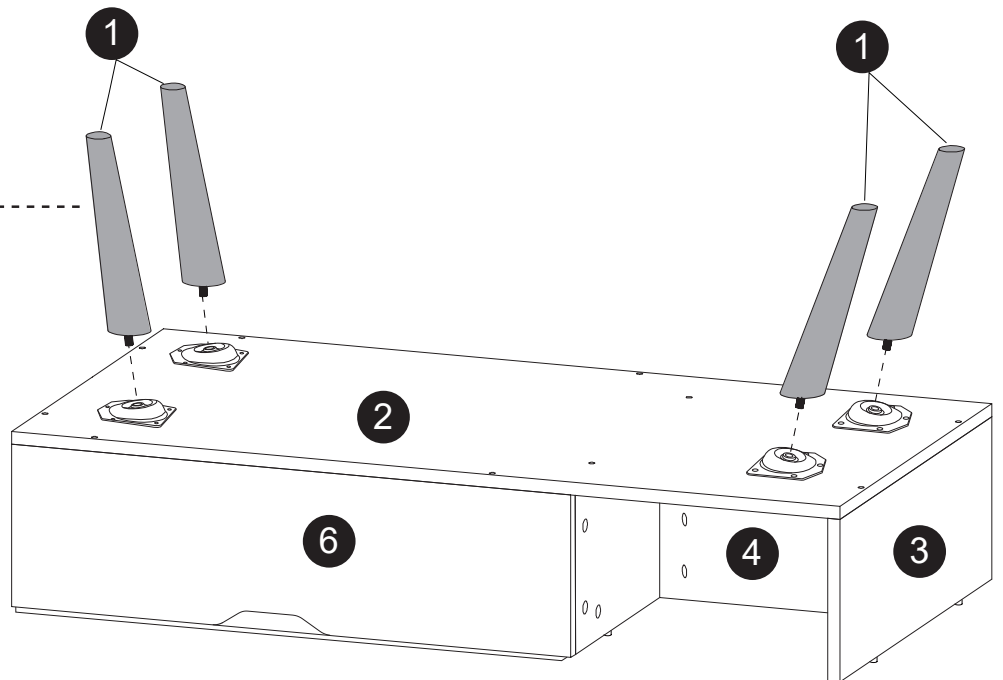
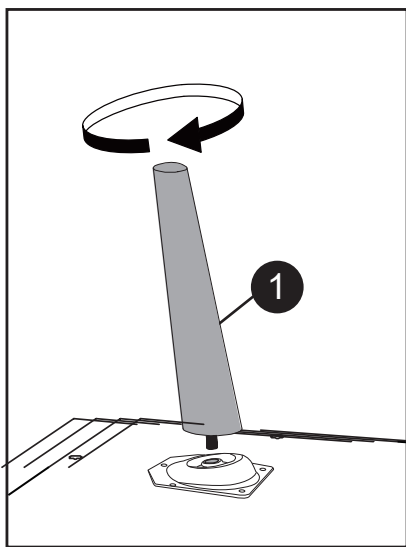

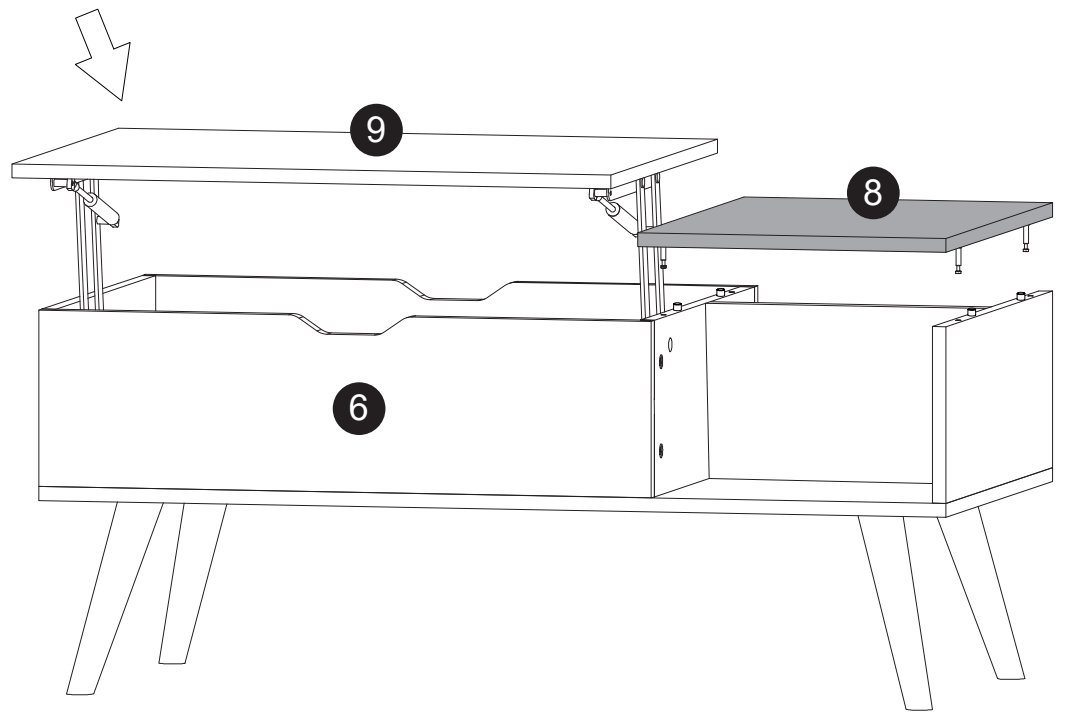
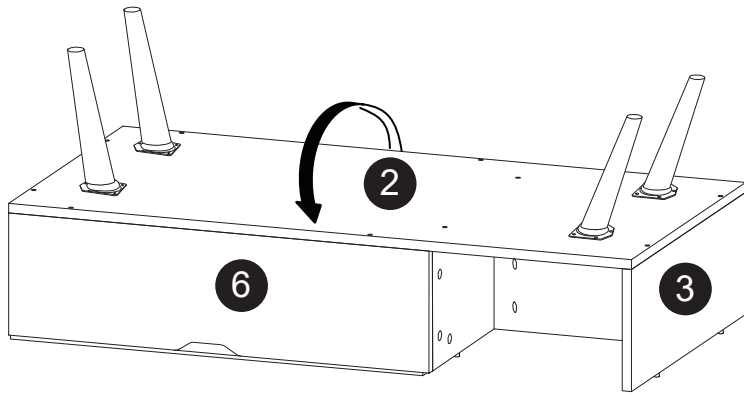

# Step 10

---



# Step 11

	
<b>C</b> x4	<b>J</b> x1

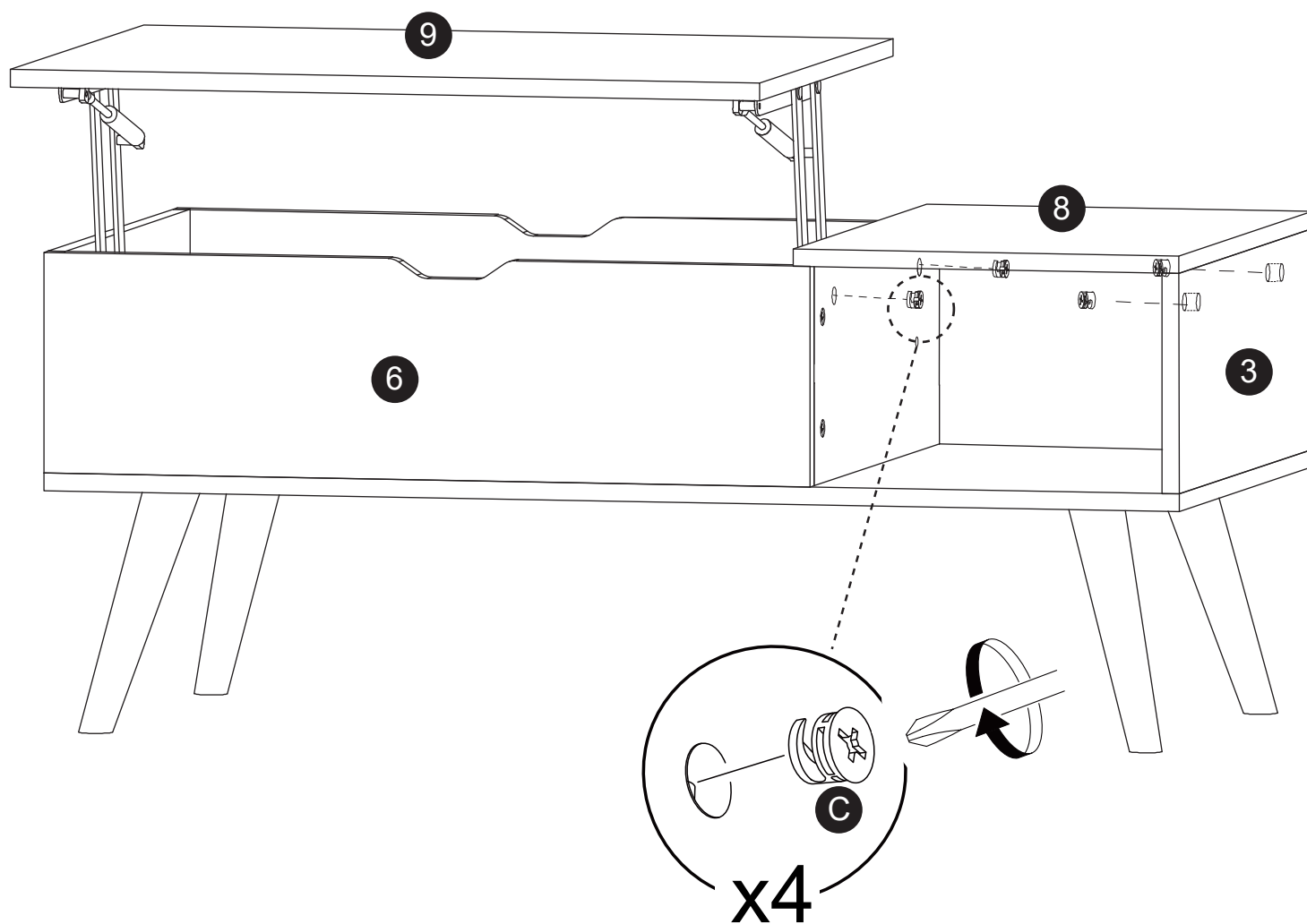

## Step 12

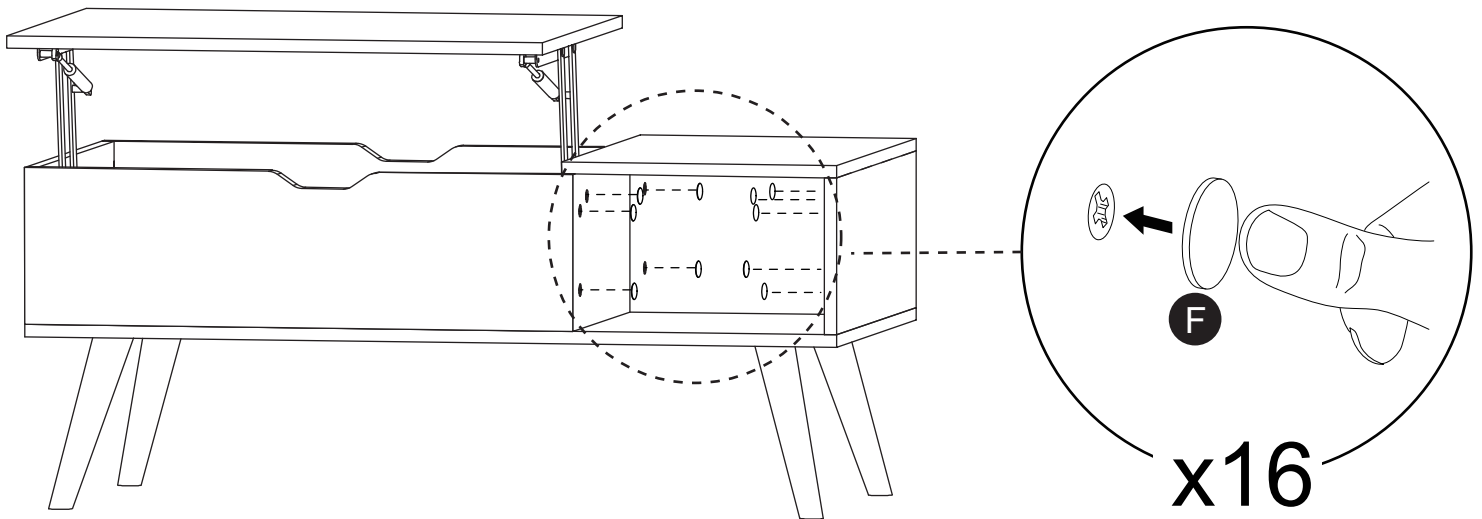
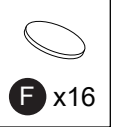

EN: Cover the cam lock holes with stickers.

ES: Cubra los orificios de la excéntrica con pegatinas.

FR: Couvrez les trous de la serrure à came avec des autocollants.

## **Servicio técnico**

6269443420 | 6267435564

## **Información adicional**

HJ-Customer-Service@outlook.com

Gracias por haber elegido este producto. Nos esforzamos por ofrecerle los productos y servicios de mejor calidad del sector. Si tiene algún problema, no dude en ponerse en contacto con nosotros.

## **Support Technique**

6269443420 | 6267435564

## **Autres Informations**

HJ-Customer-Service@outlook.com

Merci d'avoir choisi ce produit. Nous nous efforçons de vous offrir des produits et des services de la meilleure qualité dans l'industrie. Si vous rencontrez des problèmes, n'hésitez pas à nous contacter.

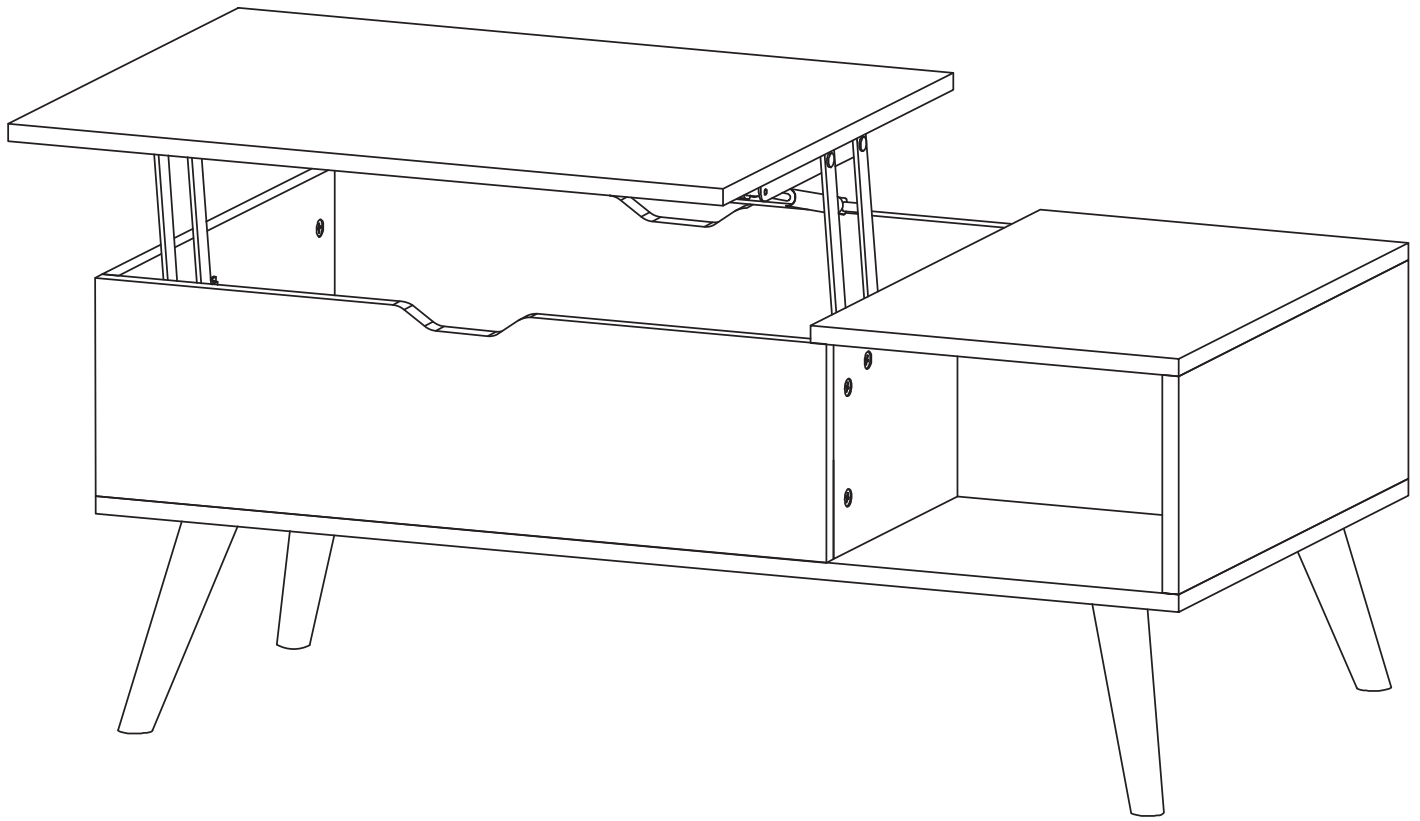

## Technical Support

6269443420 | 6267435564

## Other Info

[HJ-Customer-Service@outlook.com](mailto:HJ-Customer-Service@outlook.com)

Thank you for choosing this product. We strive to provide you with the best quality products and service in the industry. Should you have any issues, please don't hesitate to contact us.