





ASSEMBLY INSTRUCTION



Description: SOFA, POWER

Read instructions carefully prior to assembly.

Thank you for purchasing this quality product. Check carefully for small parts which may have come loose during shipment. Remove all components from pack and place top down on soft surface such as carpet or cloth to prevent scratching the finish. Identify and count all parts as specified below.

It is recommended to use two or more person during the assembly process.

PARTS LIST:			
NO.	DESCRIPTION	SKETCH	Q'TY
A	Seat Body		1 PC
B	Left Backrest		1 PC
C	Console Backrest		1 PC
D	Right Backrest		1 PC

PARTS LIST:			
NO.	DESCRIPTION	SKETCH	Q'TY
E	Left wing		1 PC
F	Right wing		1 PC
G	Power source		1 PC

Important note:

1. Carefully open and break seal of bag for backrest and seat cushions. Please let cushions fully expand for 24 HRs before putting seat covers on seat cushions.
2. After expansion insert seat cushion into seat cover and carefully zip closed.

Step 1: Attach Backrest (B/C/D) to the Seat (A).

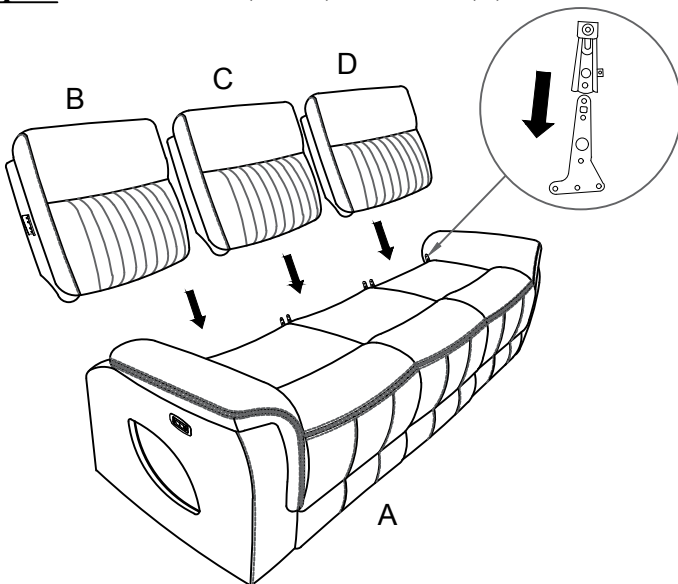

Step 2: Attach the Left/Right Wings (E/F) to the Left/Right side of the Backrest (B/D).

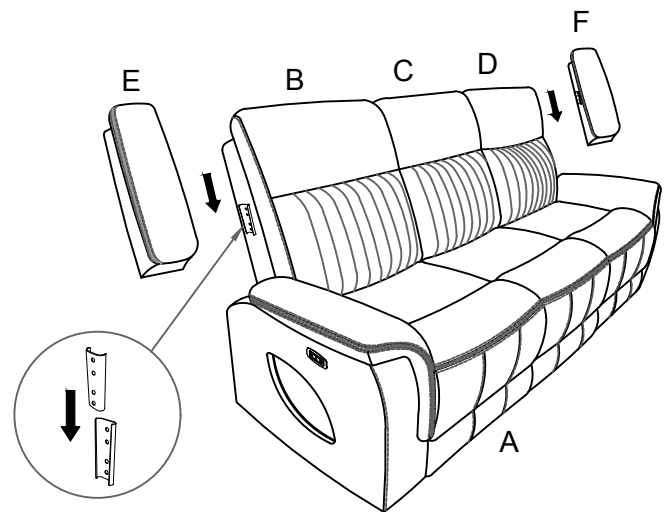

Step 3: Connect the power wire under the Armrest frame to the power source through out Power source (G).

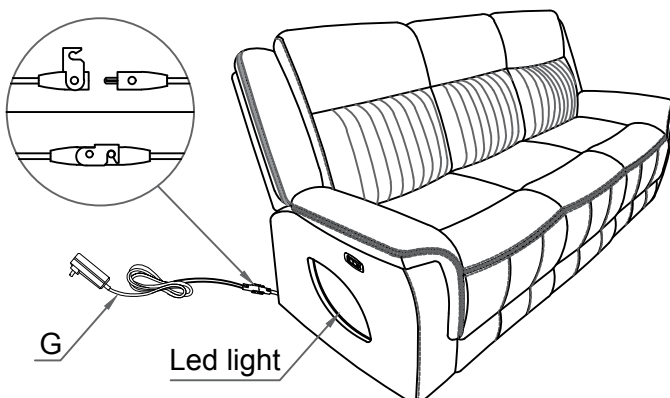

Step 4: Open the Footrest by pressing the power button on/off.

