

Please check contents before assembly. If any items are missing or damaged, do not take the unit back to the store.

PICNIC TABLE COMPONENTS

1-Table Top

4-Ea. Leg Brace

2-Ea. Bench Boards

4-Ea. Legs

2-Ea. Bench Rails

2-Ea. Table Brace

NOTE: Cracks or Checks in logs are part of the natural beauty of cedar logs and should not be considered defects.

HARDWARE

- 2 - 3 1/2" Bolts W/Nuts & Washers
- 8 - 4" Bolts W/Nuts & Washers
- 8 - 6" Bolts W/Nuts & Washers
- 8 - 4" Lag Screws
- 2 - 5" Lag Screws

TOOLS REQUIRED

Optional: Battery or electric power drill will make assembly easier and faster.

NOTE: Using a battery Or electric power drill with a socket attachment will make assembly easier and faster.

STEP 1 Lay the table top on a clean dry smooth surface as shown in **Figure 1**.

Figure 1

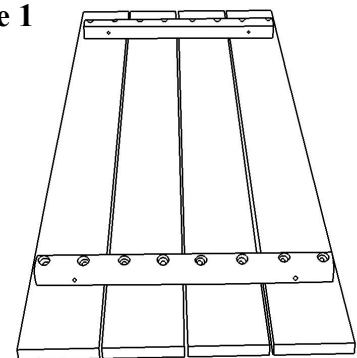

STEP 2 Position legs on the four corners, the side of the leg with the larger bore hole should be facing toward the center of the table (Note: each pair of legs are opposites). Install 4 of the 6" bolts through the table cleats into the legs as shown in **Figure 2 & 3**. Install the washers and nuts as shown in **Figure 3**. Do not tighten these down completely at this time. (Note: the table legs may not set flush to the table top, this is normal).

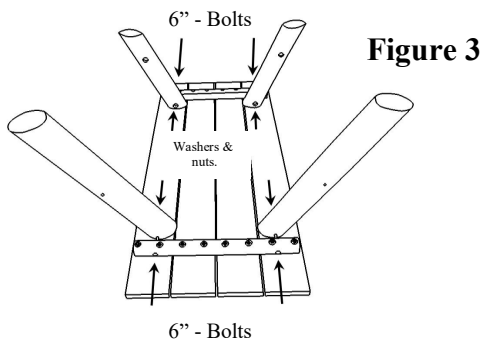

Figure 2

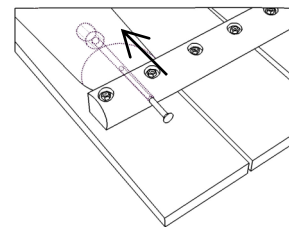
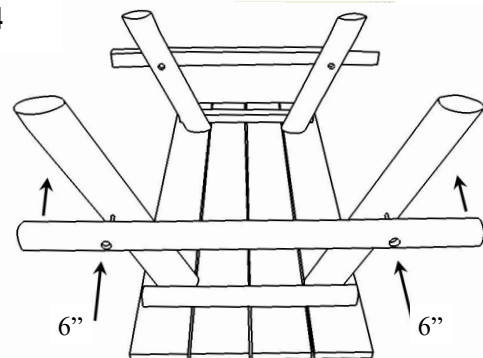

Figure 4

STEP 3 Attach bench rails with 6" bolts, nuts & washers as show in **Figure 4**. Position the bench rails with the flat side against the legs with counter bore holes facing out, the counter bore holes for the benches should be facing up (Once table is flipped over these holes will be facing toward the ground). Install the 6" bolt through bench rail and then through leg, use washers and nuts to secure (Do not completely tighten).



Carefully flip the table over onto its legs. Level the top, then tighten down all nuts.

STEP 4 **Note: Make sure the table top is parallel to the bench rail before attaching leg braces.**

Attach the four 9" leg braces with the 4" lag screws as shown in **Figure 5**. Center the brace to the legs and bench rail logs. Tap in 1/2" with a hammer to start lag screw.

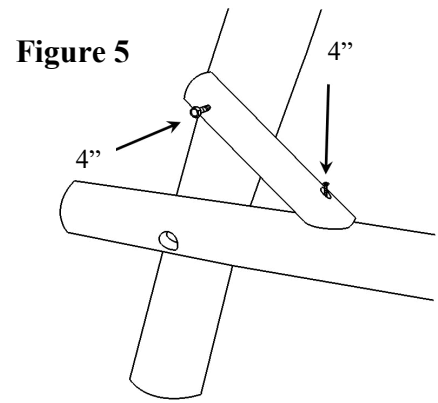

STEP 5 Attach the table brace with 3 1/2" bolts, nuts, & washers to the table top as shown in **Figure 6**, with bolts going through the center holes of the two center table boards.

STEP 6 Attach the bench boards with 4" bolts, nuts & washers as shown in **Figure 7**. (If necessary: adjust bench rails to allow the bolts to drop into the holes of the bench by loosening the bench rail nuts from the legs.)

STEP 7 Attach the other end of the table brace to center of bench rail with the 5" Hew Washer Head Screw as shown in **Figure 8**.

Figure 6

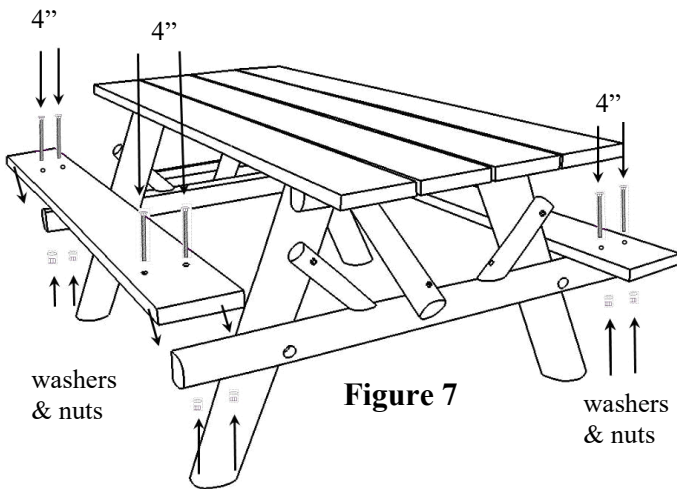
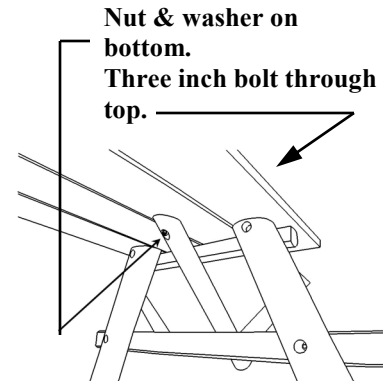

Figure 7

STEP 8 Tighten all nuts, screws, and lag screws firmly until pieces are tight together. Your table is now ready for use.

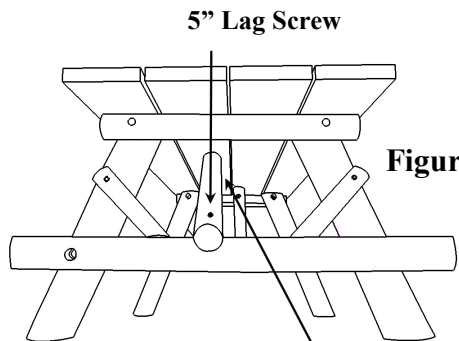

Figure 8

**Nut & washer on bottom.
Three inch bolt through top.**

