

# BED

## FULL/ QUEEN SIZE

### ASSEMBLY INSTRUCTIONS

#### PARTS AND FITTING PACKAGING DETAIL

##### BOX #1

- A. HEADBOARD 1 PC
- B. FOOTBOARD 1 PC

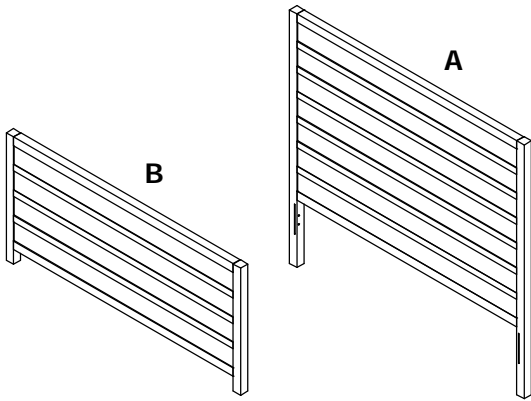

##### BOX #2

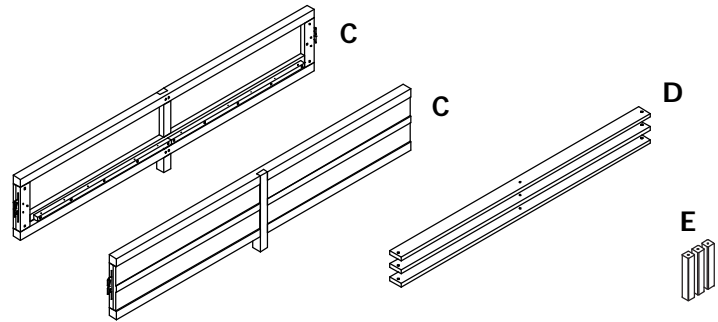

- C. SIDERAILS 2 PCS
- D. BED SLATS 3 PCS
- E. LEG SUPPORT 3 PCS
- HARDWARE BOX\*

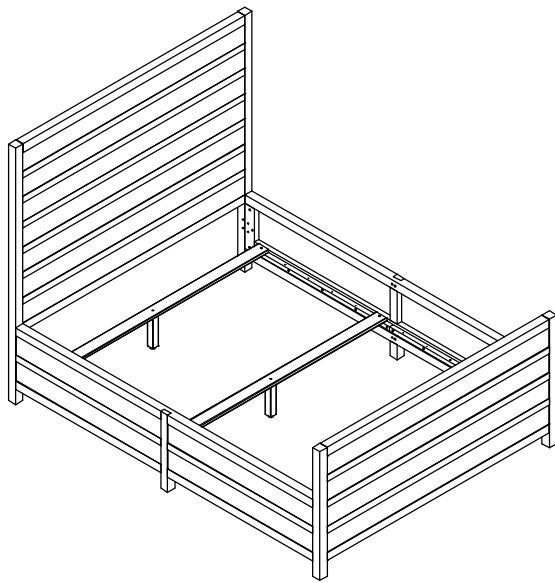

#### BED ASSEMBLED

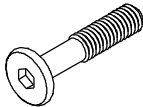

#### HARDWARE PACKED IN BOX #2

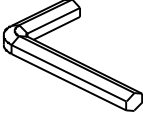
1	ALLEN BOLT 40MM	3 PCS	2	WOOD SCREW Ø8X30MM	6 PCS
					
3	ALLEN KEY	1 PC	<b>YOUR BOX MAY CONTAIN EXTRA HARDWARE</b>		
					

**TOOL REQUIRED :**  
PHILLIPS HEAD SCREW  
DRIVER (NOT PROVIDED)

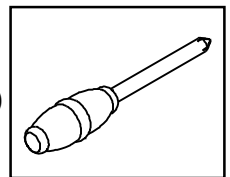

#### STEP 1 :

FIX ONE OF THE SIDERAILS (C) TO THE HEADBOARD (A) BY SLIDING IN THE HOOK INSTALLED AT THE END OF THE SIDERAIL (C) TO THE HEADBOARD (A), AND PUSH DOWN THE SIDERAIL (C) TO SECURE THE CONNECTION.

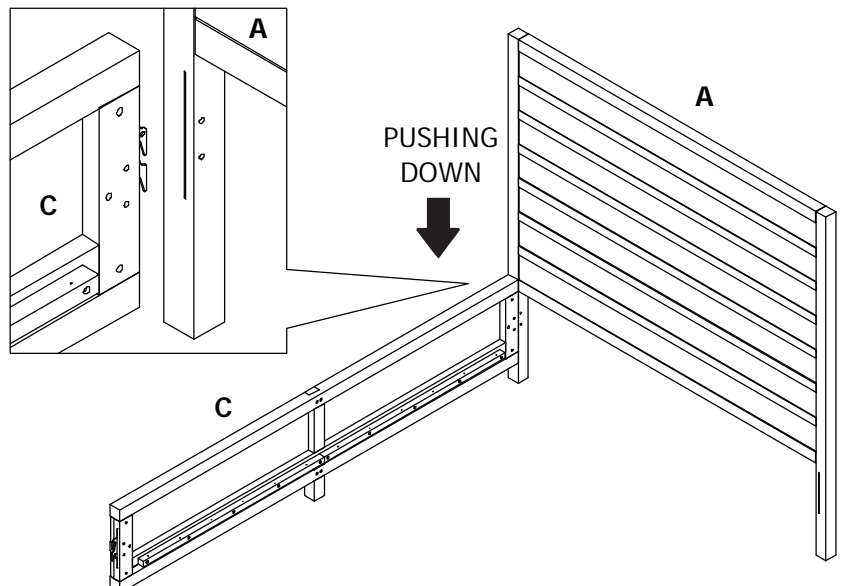

## STEP 2 :

FIX THE OTHER END OF THE SIDERAIL (C) TO THE FOOTBOARD (B).

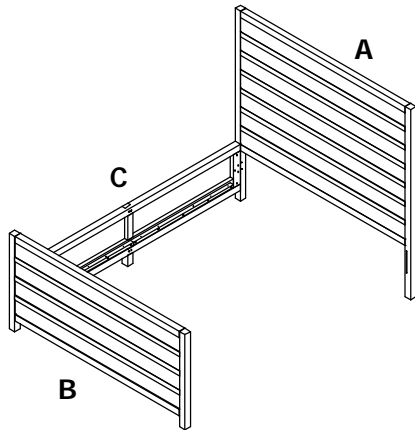

## STEP 3 :

REPEAT THE SAME WAY FIX THE OTHER SIDERAIL (C) TO THE HEADBOARD (A) AND FOOTBOARD (B).

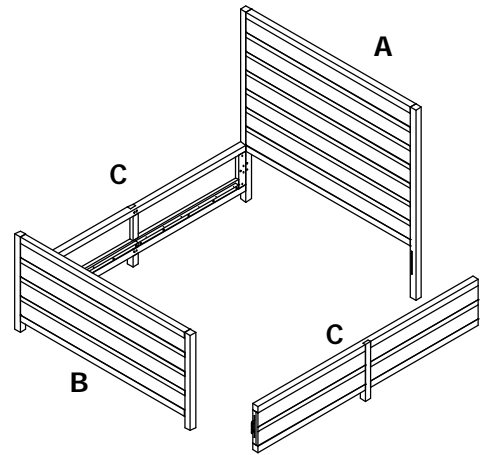

## STEP 4 :

FOLLOW THE ILLUSTRATION TO PLACE THREE BED SLATS (D) ON THE BED FRAME AND THE BED SLATS (D) USING WOOD SCREWS (2). USE THE PILOT HOLES ON THE SIDERAILS (C) AS YOUR REFERENCE FOR EASY ASSEMBLY.

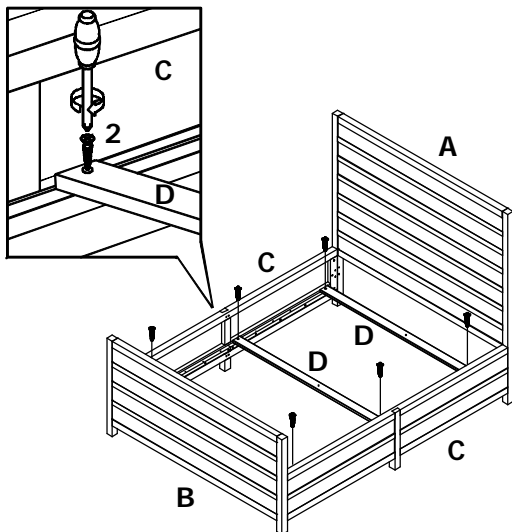

## STEP 5 :

FOLLOW THE ILLUSTRATION TO FIX THE LEG SUPPORT (E) TO BED SLATS (D) USING ALLEN BOLTS (1). USE ALLEN KEY (3) TO TIGHTEN THE BOLTS. MAKE SURE ALL BOLTS AND SCREWS ARE TIGHTENED BEFORE USING.

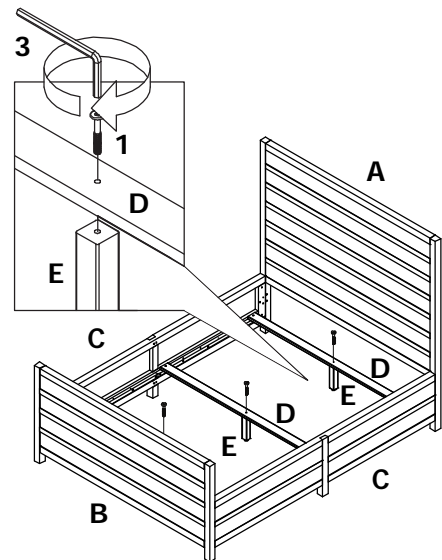

## INSTRUCTIONS FOR ADJUSTING LEVELERS :

POSITION THE BED IN YOUR ROOM. LOCATE LEVELERS UNDER EACH LEG SUPPORT.

TURN COUNTER-CLOCKWISE TO EXTEND, CLOCKWISE TO CONTRACT.

ADJUST LEVELERS UNTIL EACH LEG SUPPORT IS APPLYING EQUAL UPWARD PRESSURE ON THE BED SLAT.

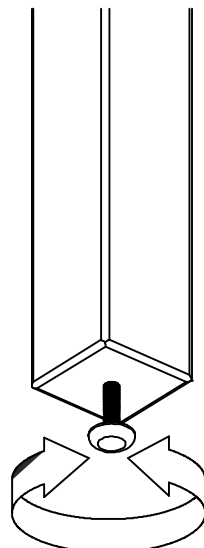

## MAINTENANCE INSTRUCTIONS :

- REMOVE BOX SPRING AND MATTRESS BEFORE MOVING YOUR BED.
- LIFT YOUR BED WHEN MOVING IT. DRAGGING CAN DAMAGE LEG SUPPORT.
- READJUST LEVELERS AFTER MOVING YOUR BED.