

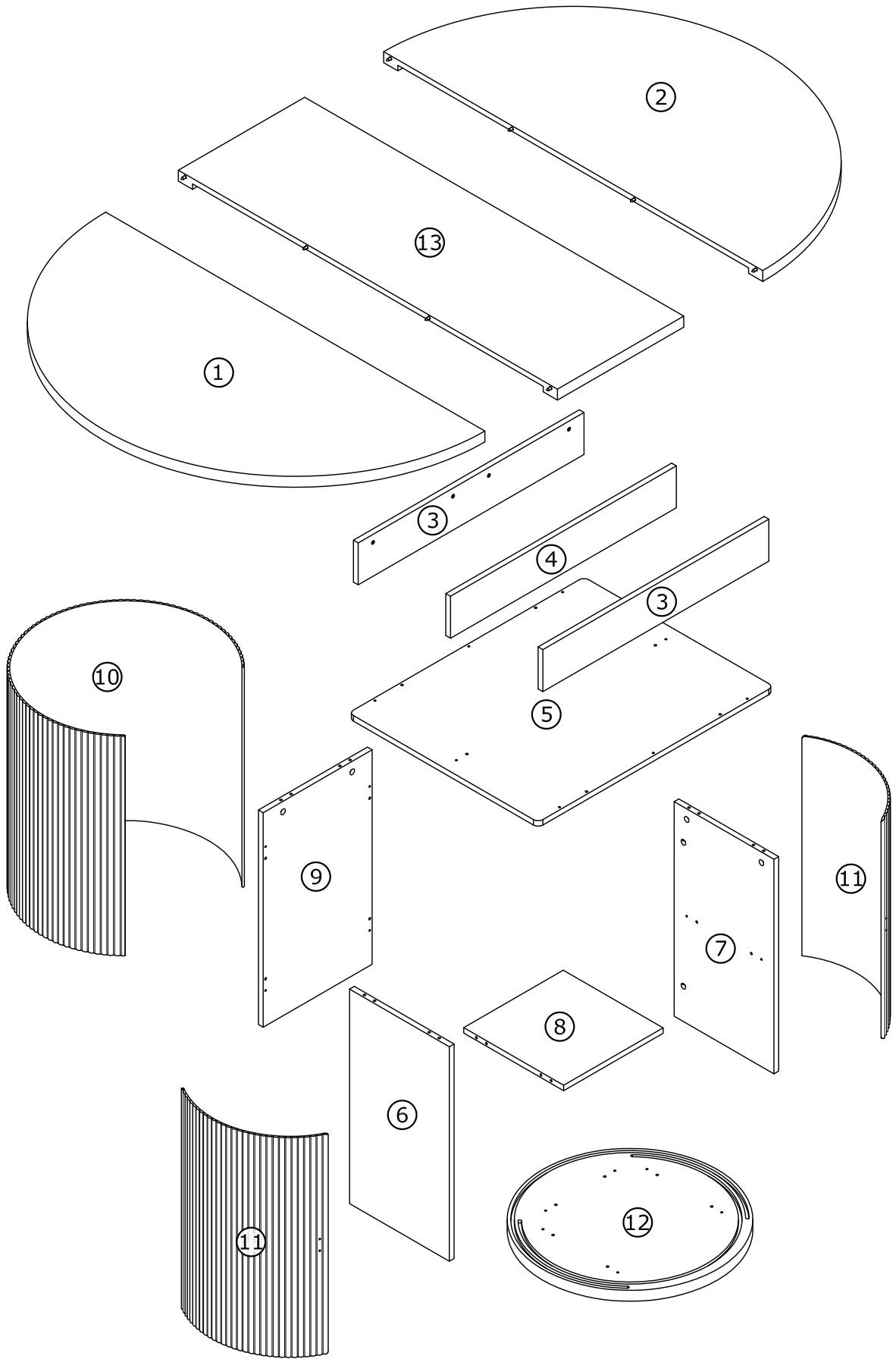

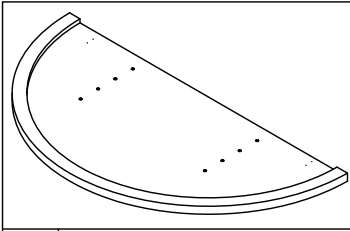

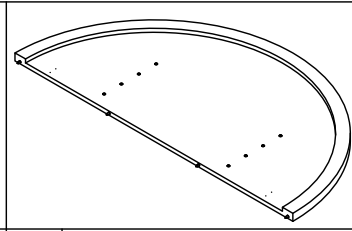

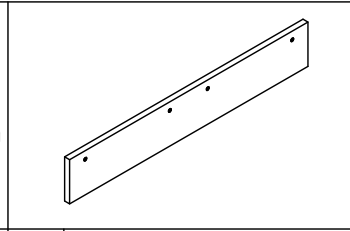
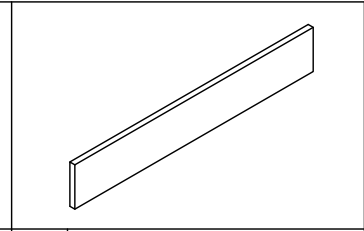
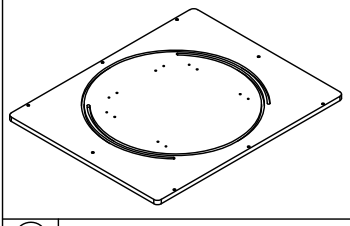
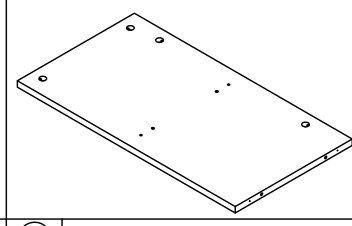
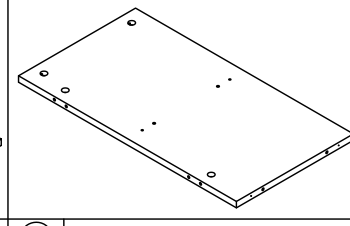
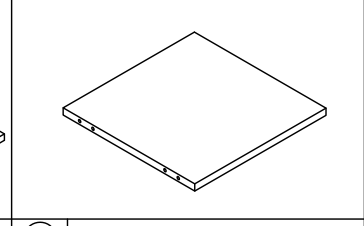
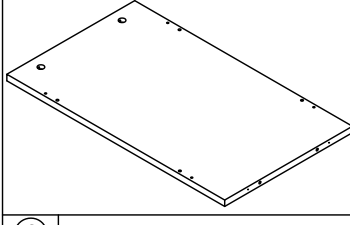
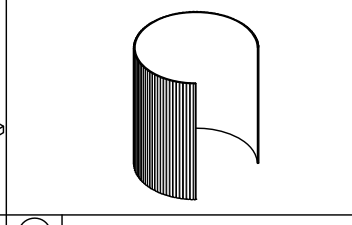
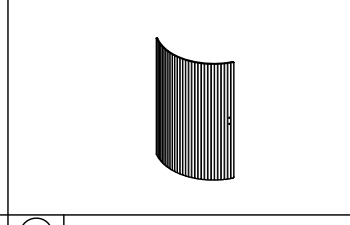
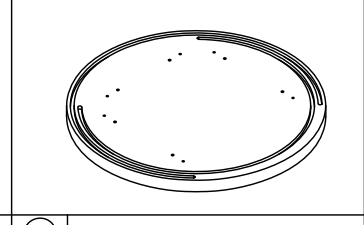
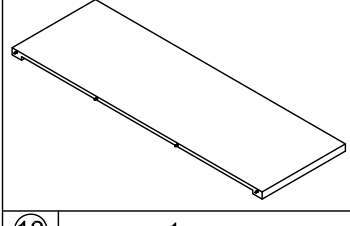

Installation instruction

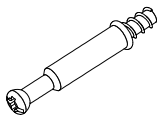

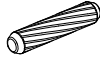
Parts and Operation Elements

			
① 1pc	② 1pc	③ 2pcs	④ 1pc
			
⑤ 1pc	⑥ 1pc	⑦ 1pc	⑧ 1pc
			
⑨ 1pc	⑩ 1pc	⑪ 2pcs	⑫ 1pc
			
⑬ 1pc			

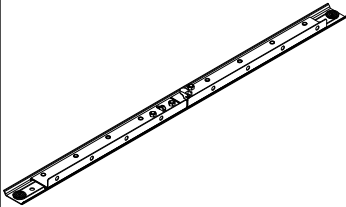
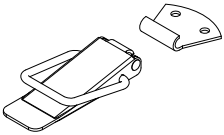
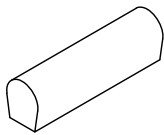
Hardware

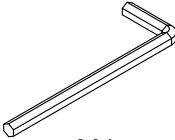
							
Cam bolt		Cam lock		6 x 30mm Wood dowel		Ø4 x 40mm	
A	14+1pcs	B	14+1pcs	C	26+1pcs	D	14+1pcs
							
3.5 x 12mm		Ø4 x 14mm					
E	16+1pcs	F	4pcs	G	2pcs	H	4sets
							
		M6 x 10mm		M4			
I	2pcs	J	24+1pcs	K	1pc		



SPARE BAG

THE SPARE BAG INCLUDED EXTRA HARDWARE FOR DAMAGED OR MISSING SMALL HARDWARE WHILE YOU ARE ASSEMBLING

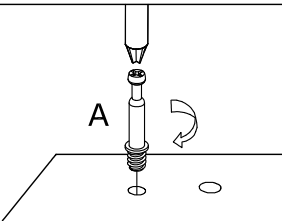
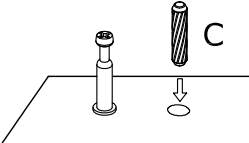
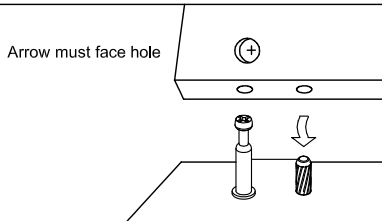
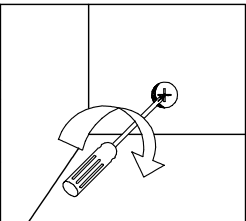
			
Gently screw cam bolt into the threaded anchor	Insert the wood dowel halfway into hole		Screw the camlock firmly into locked position.

1

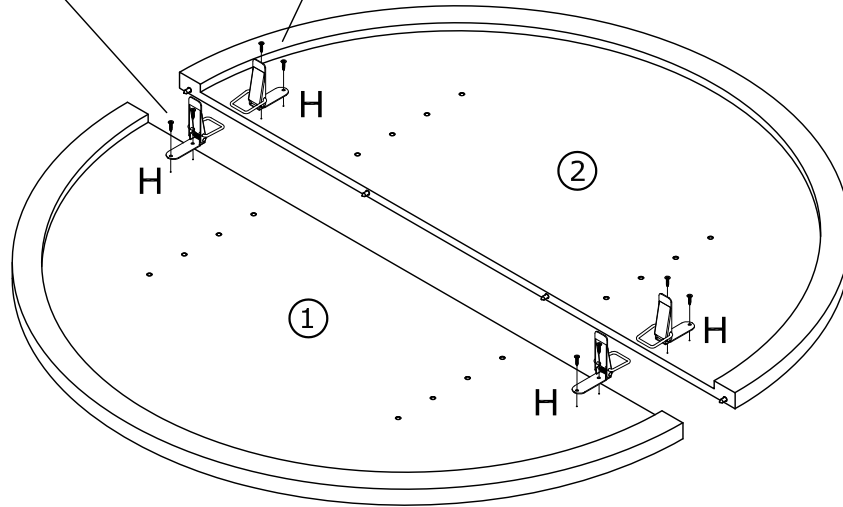
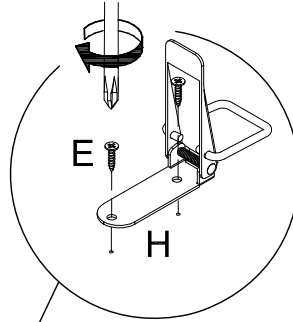
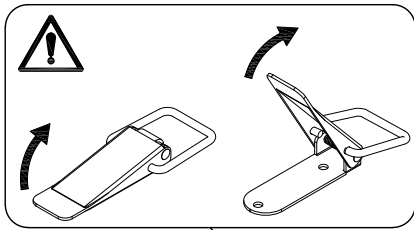
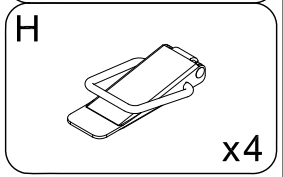
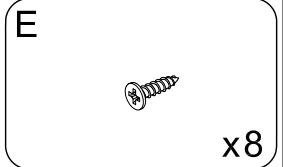

2

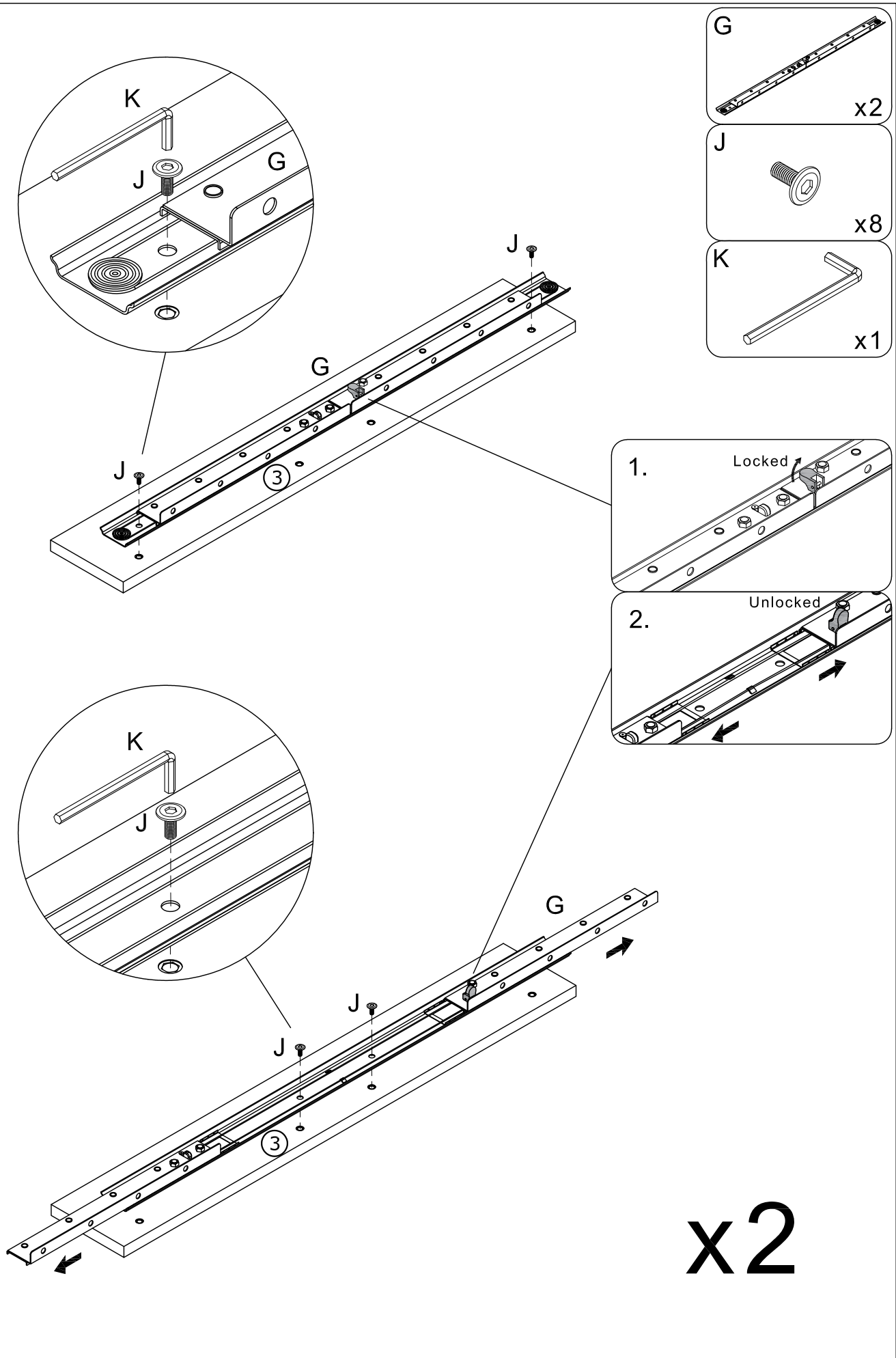

3

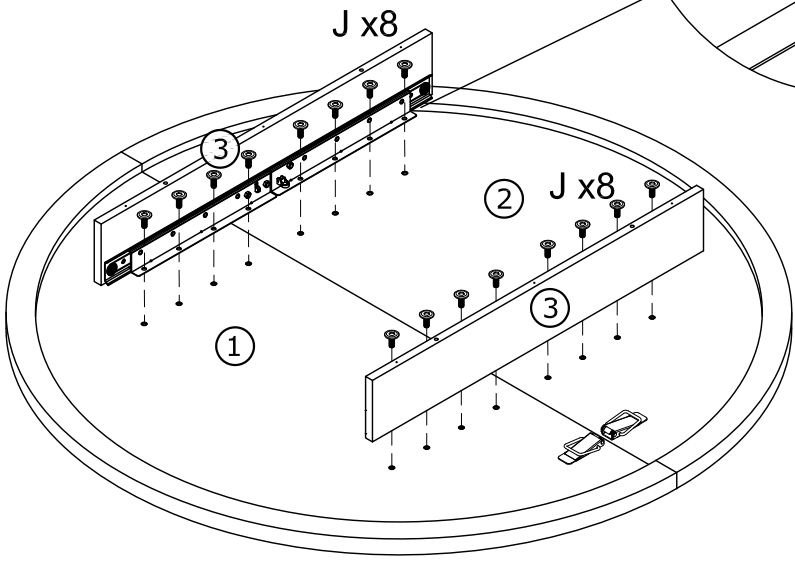
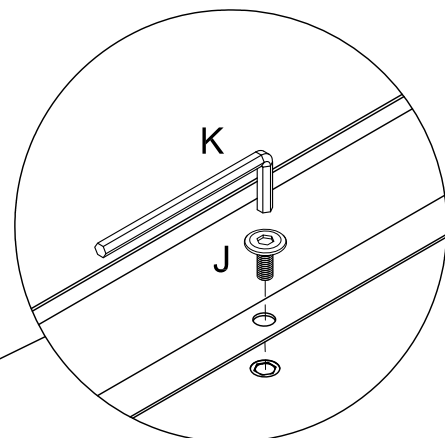
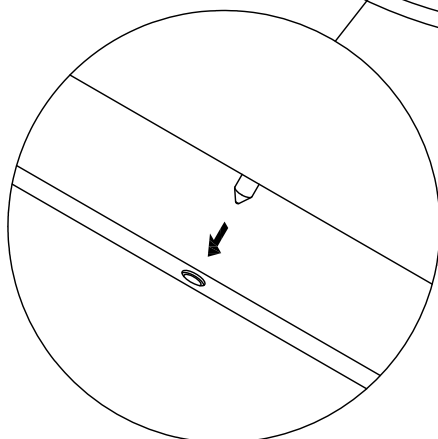
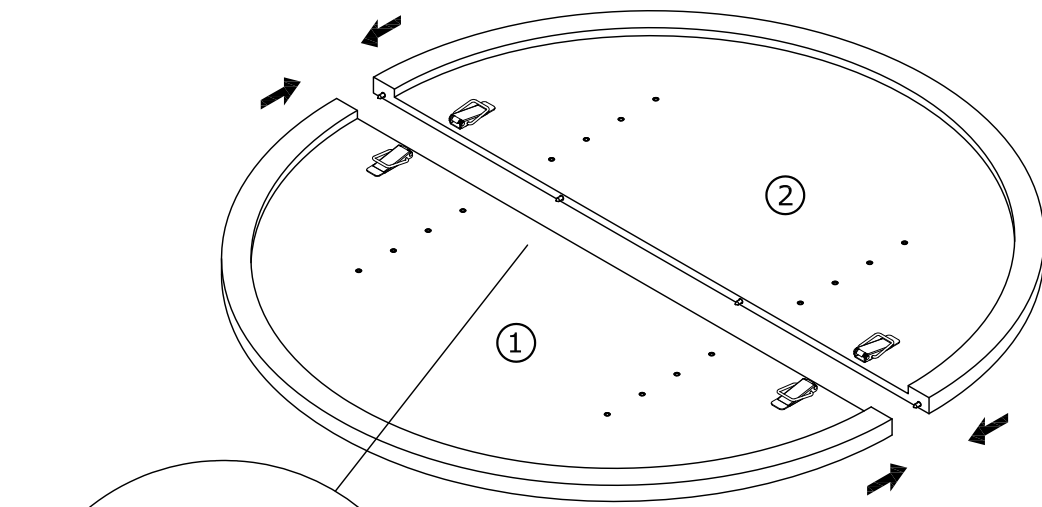
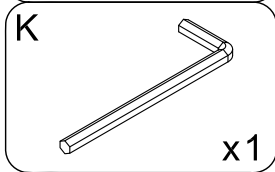
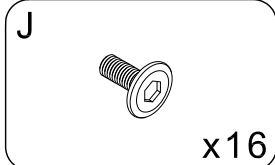

4

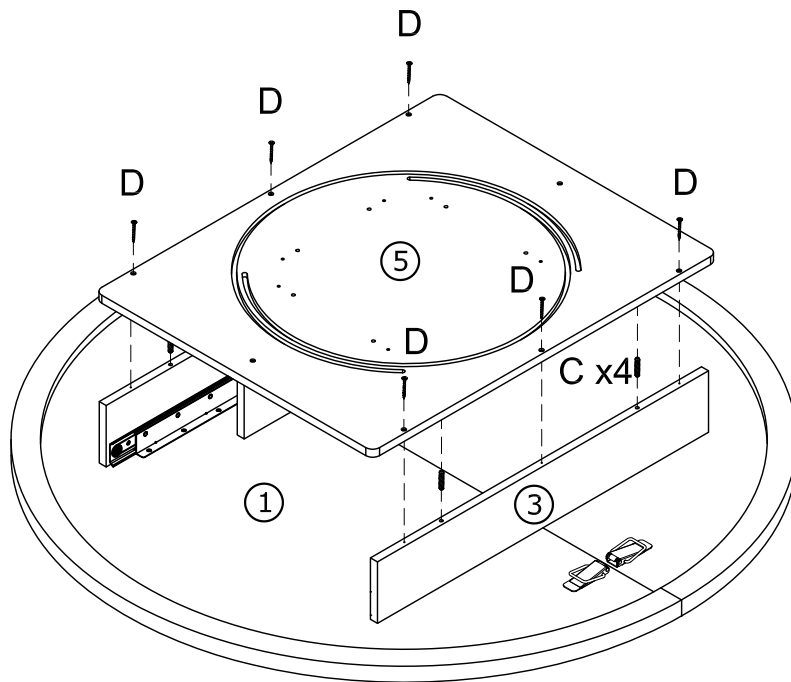
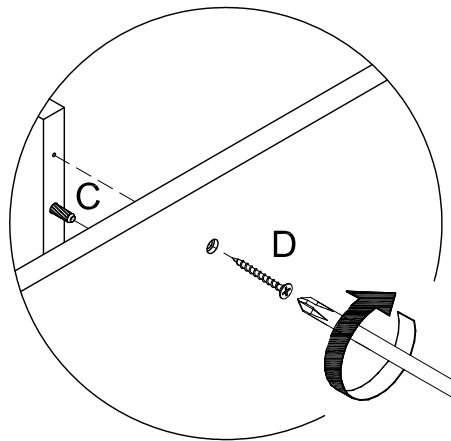
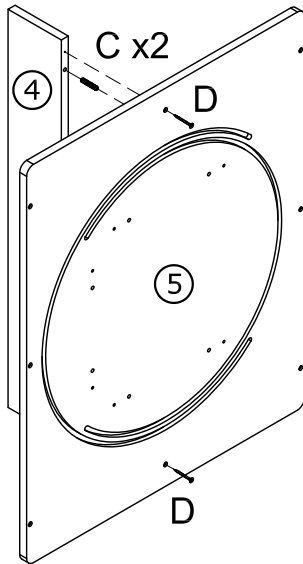
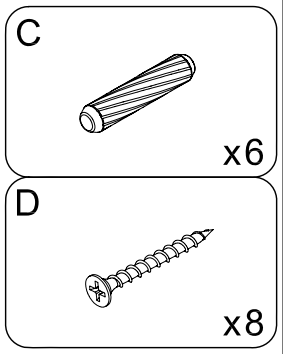

5

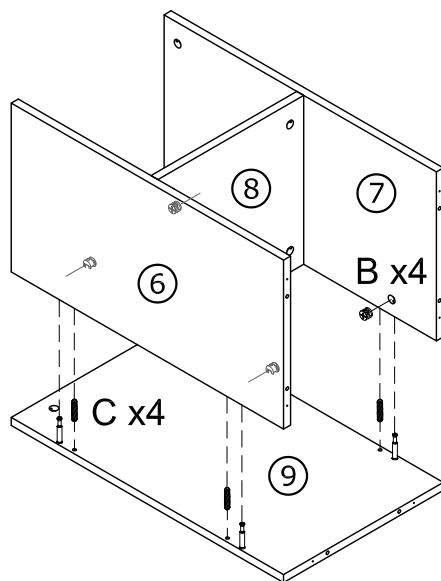
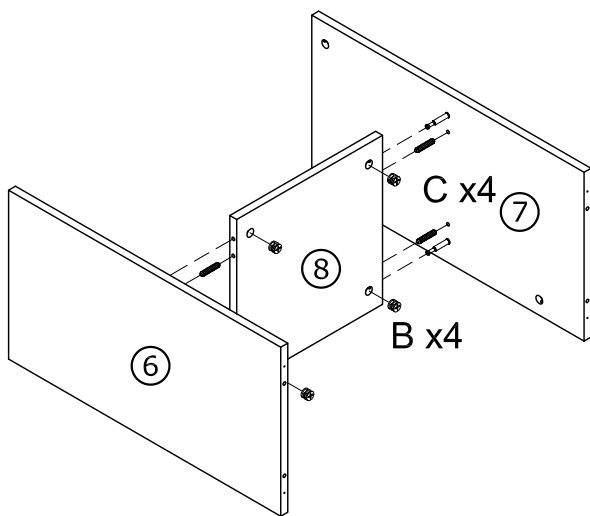
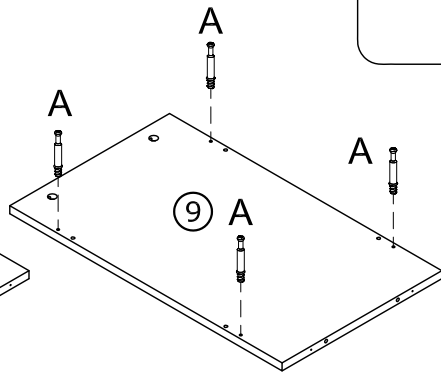
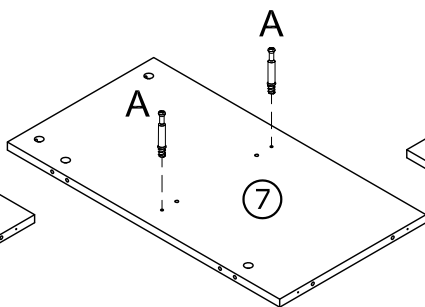
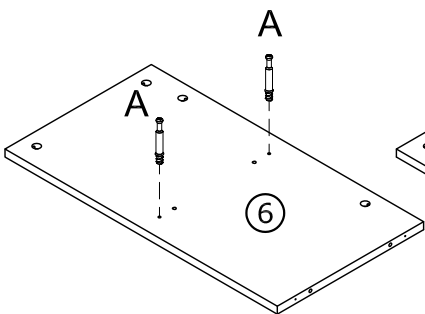
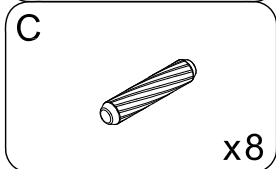
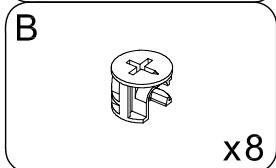
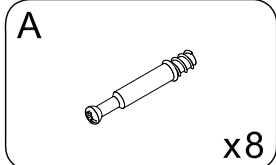
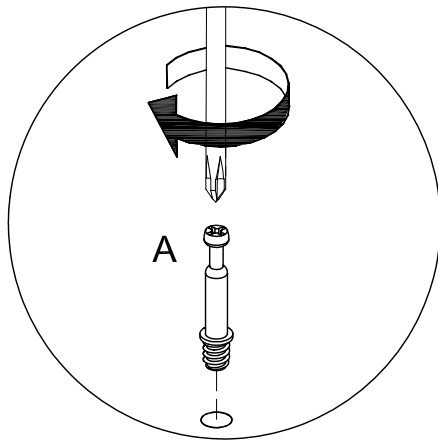

6

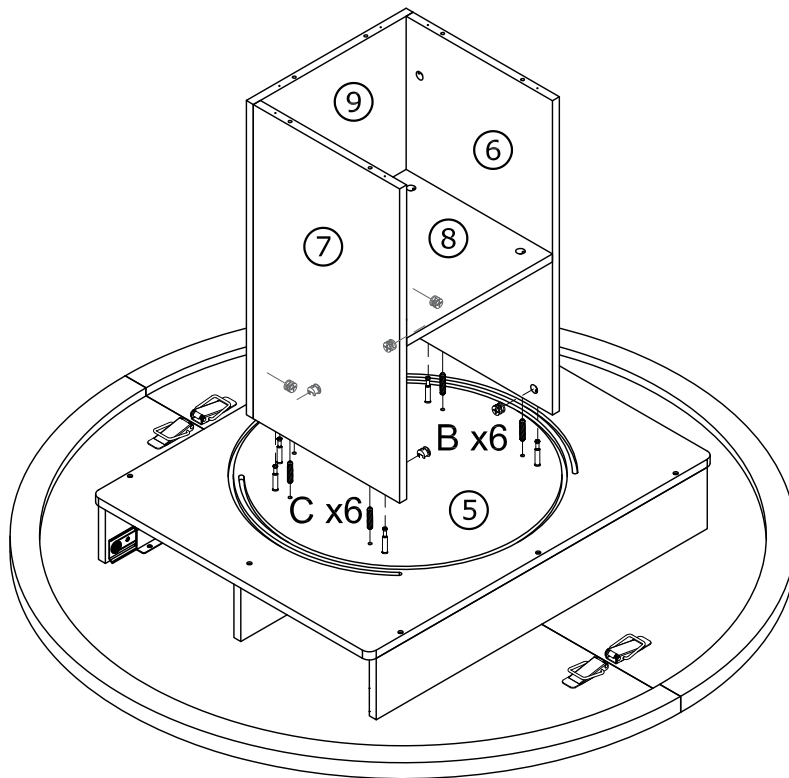
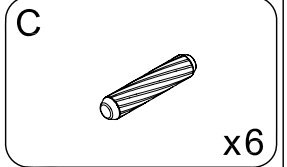
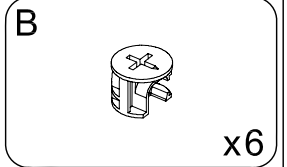
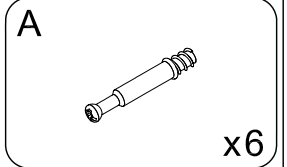
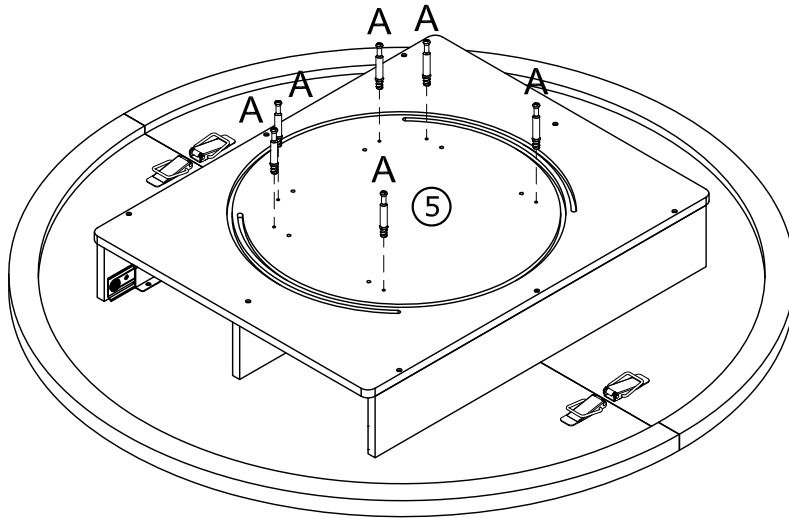

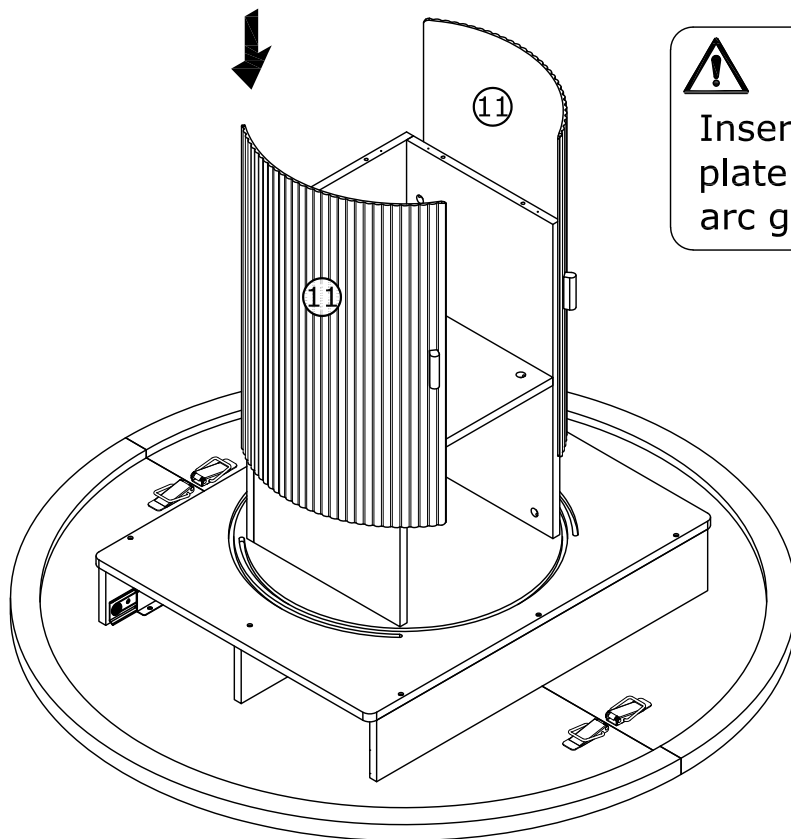
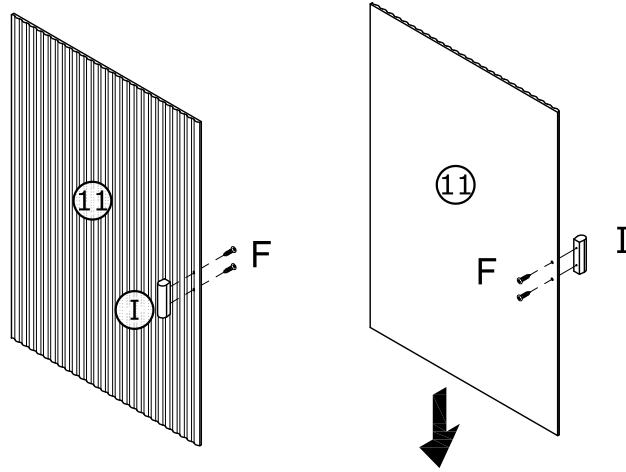
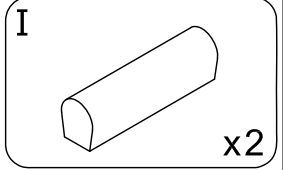
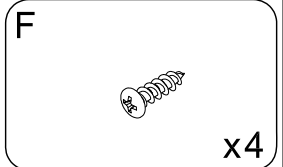
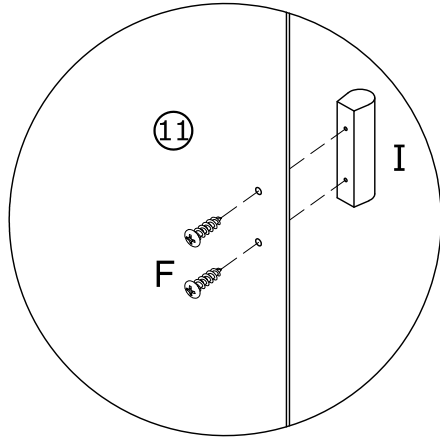

7

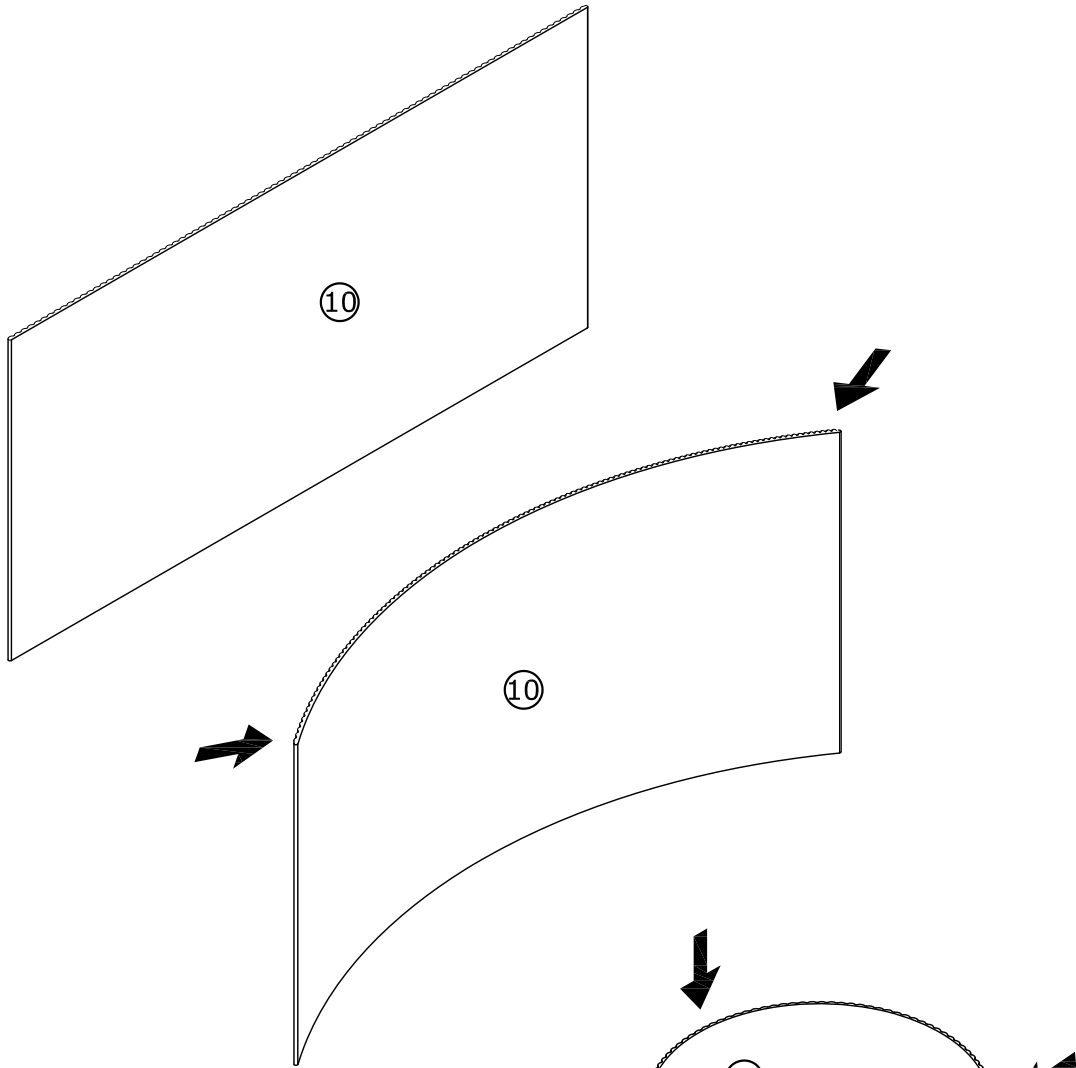

 Insert the No. 11 plate into the inner arc groove

8



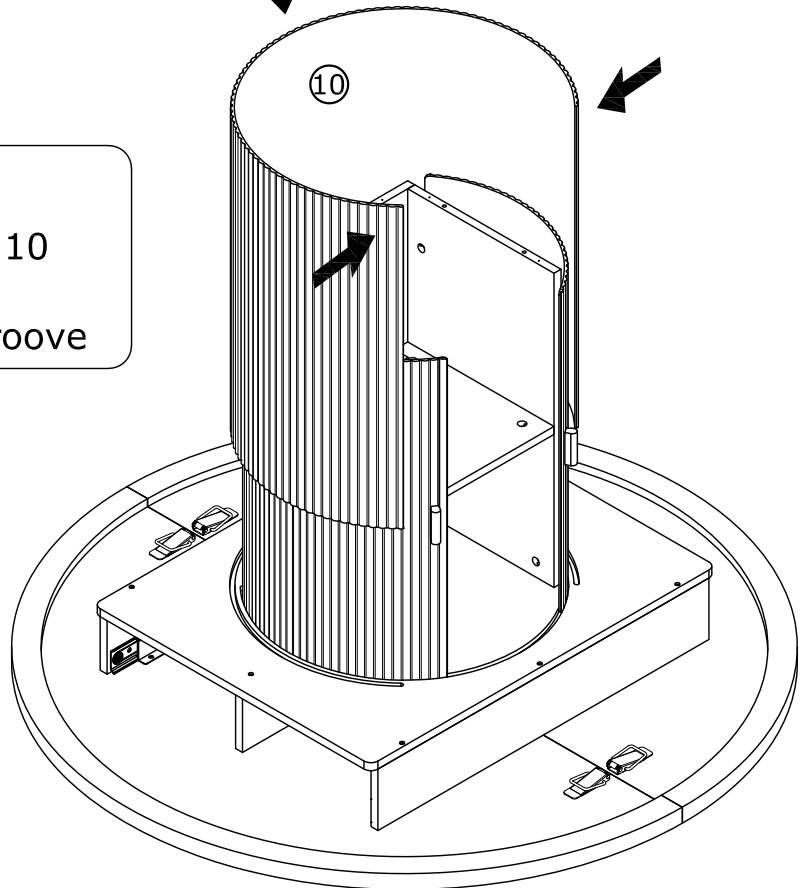

Insert the No.10
plate into the
outside arc groove



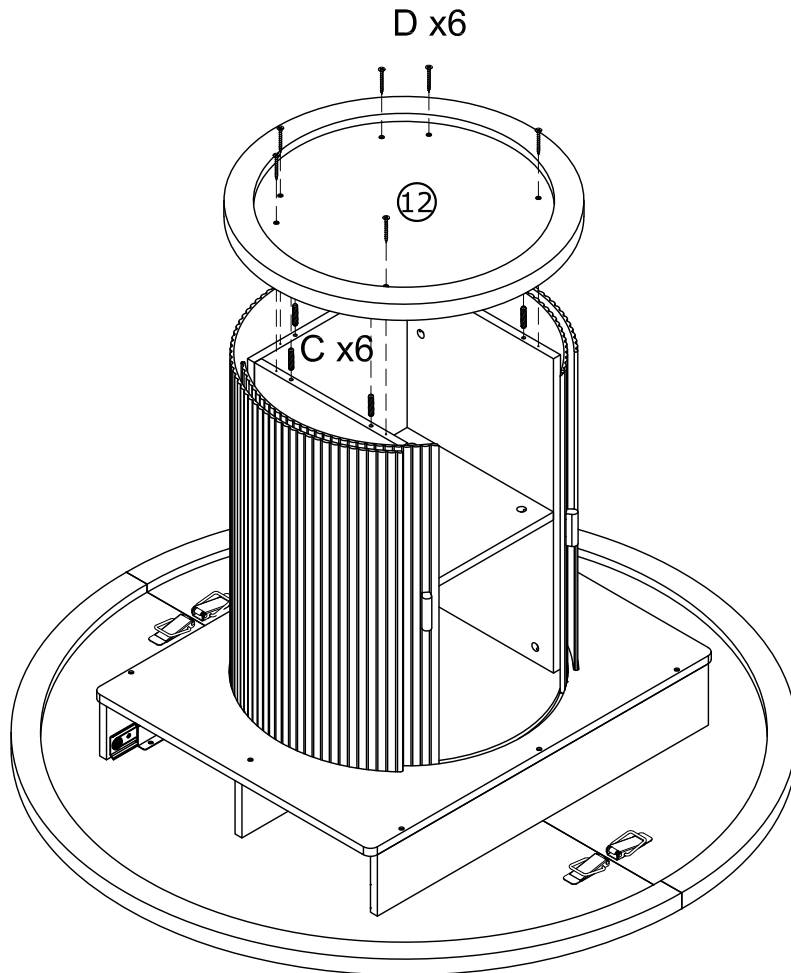
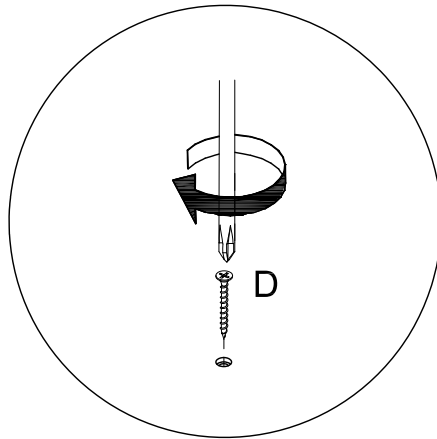
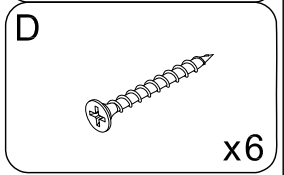
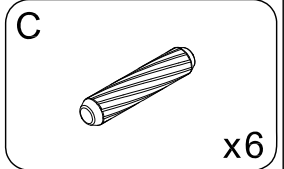

9

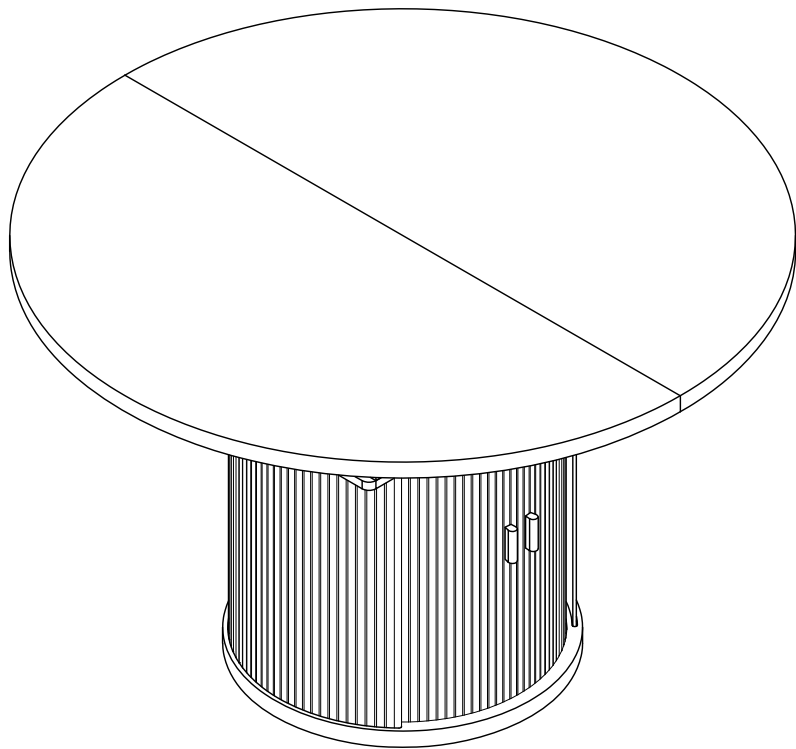

Round table



10

- E  x8
- H  x4

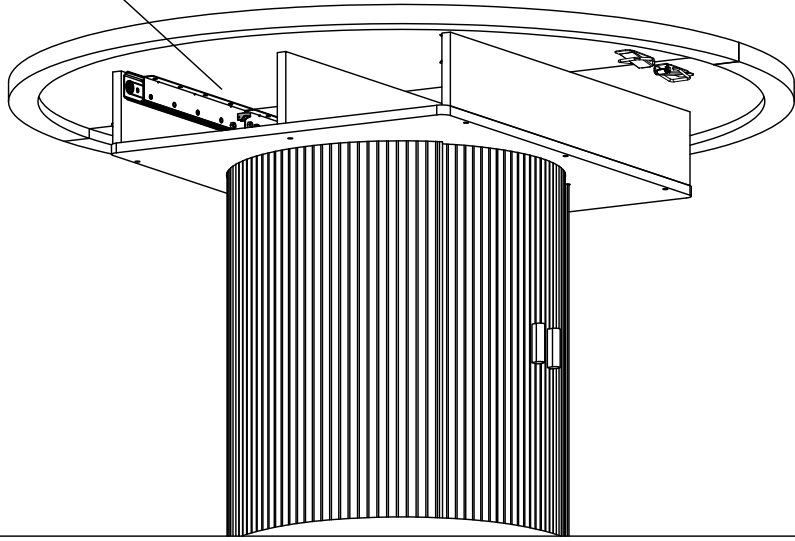
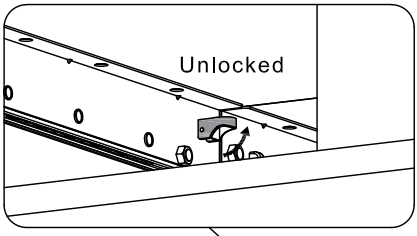
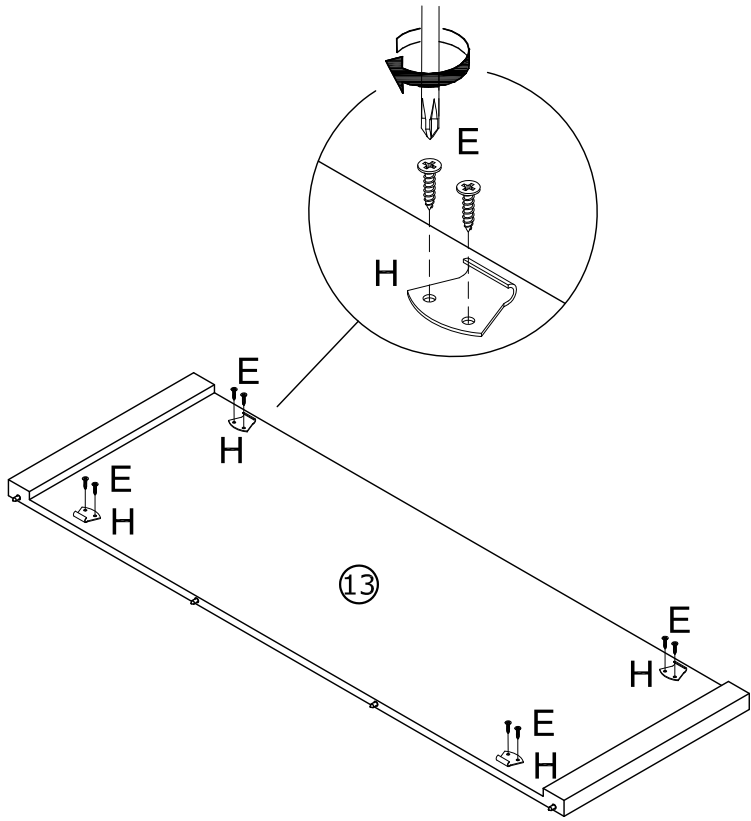

11

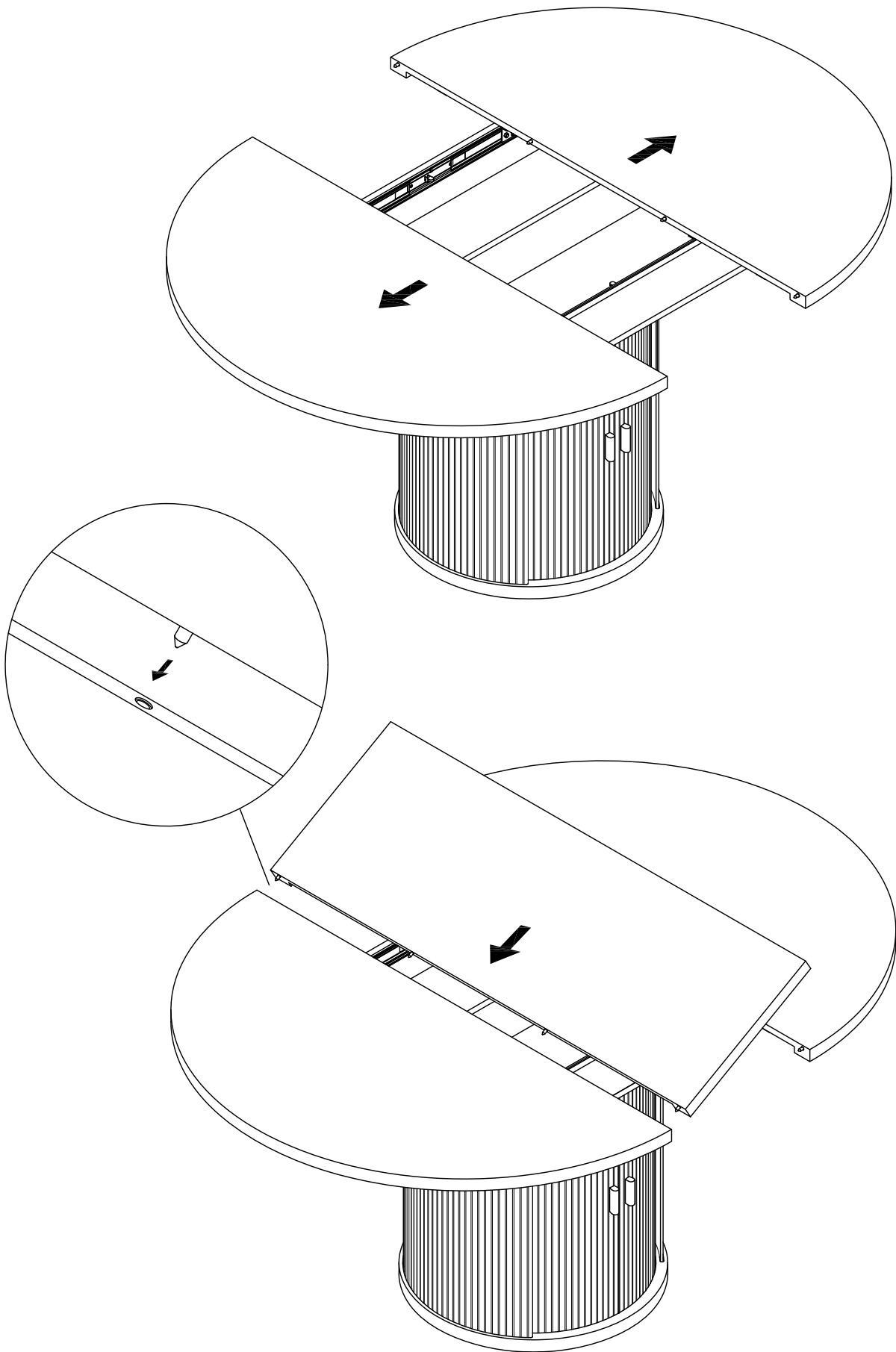

12

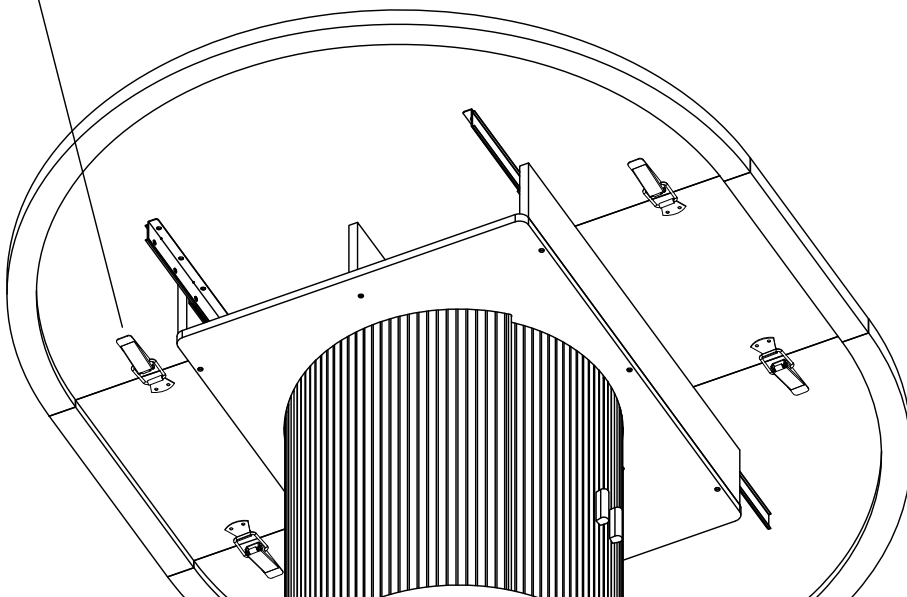
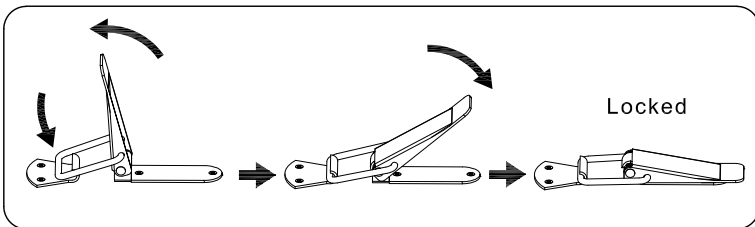
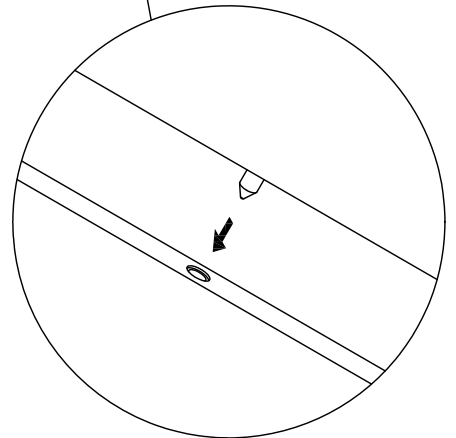
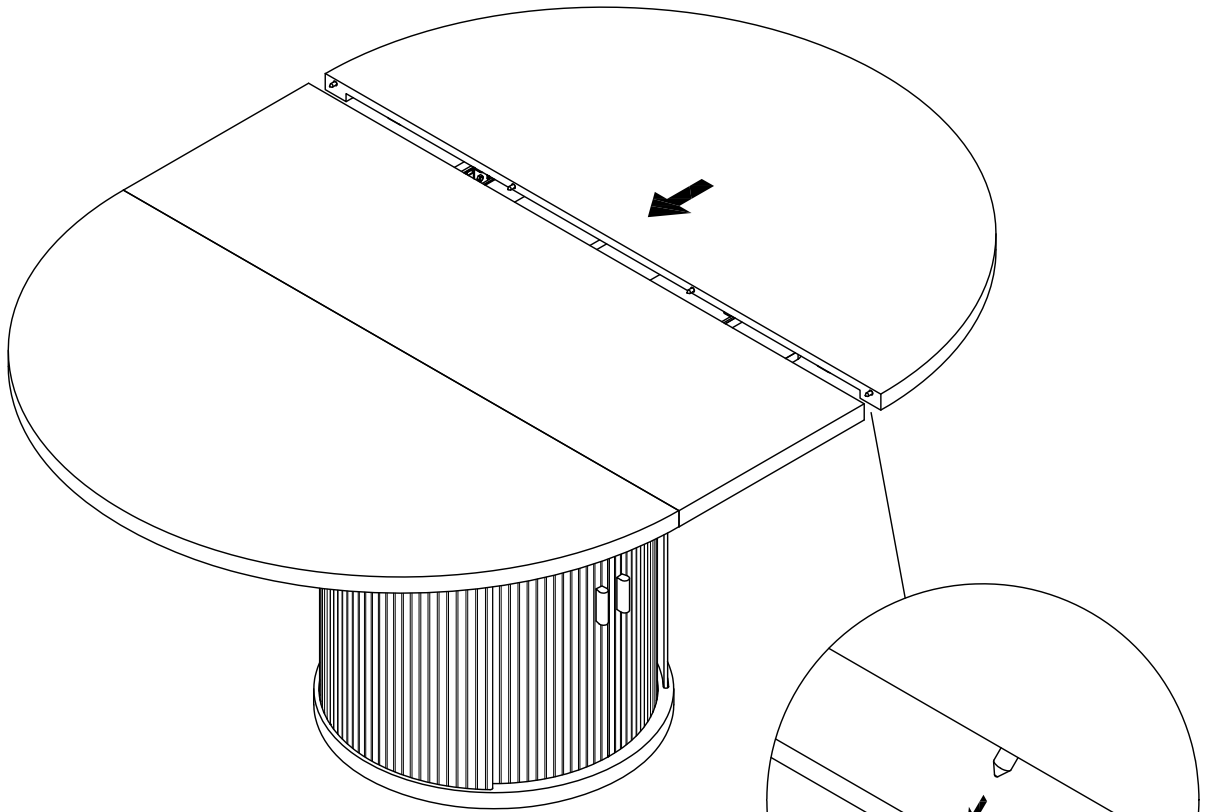

Long table

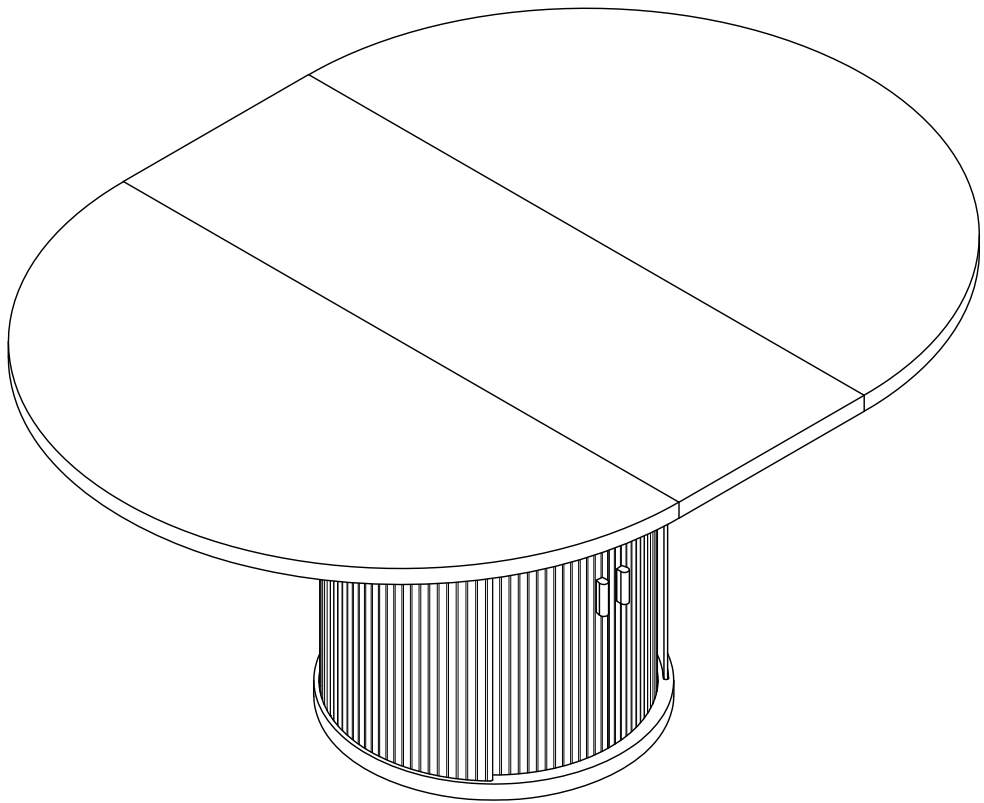

Long table to round table

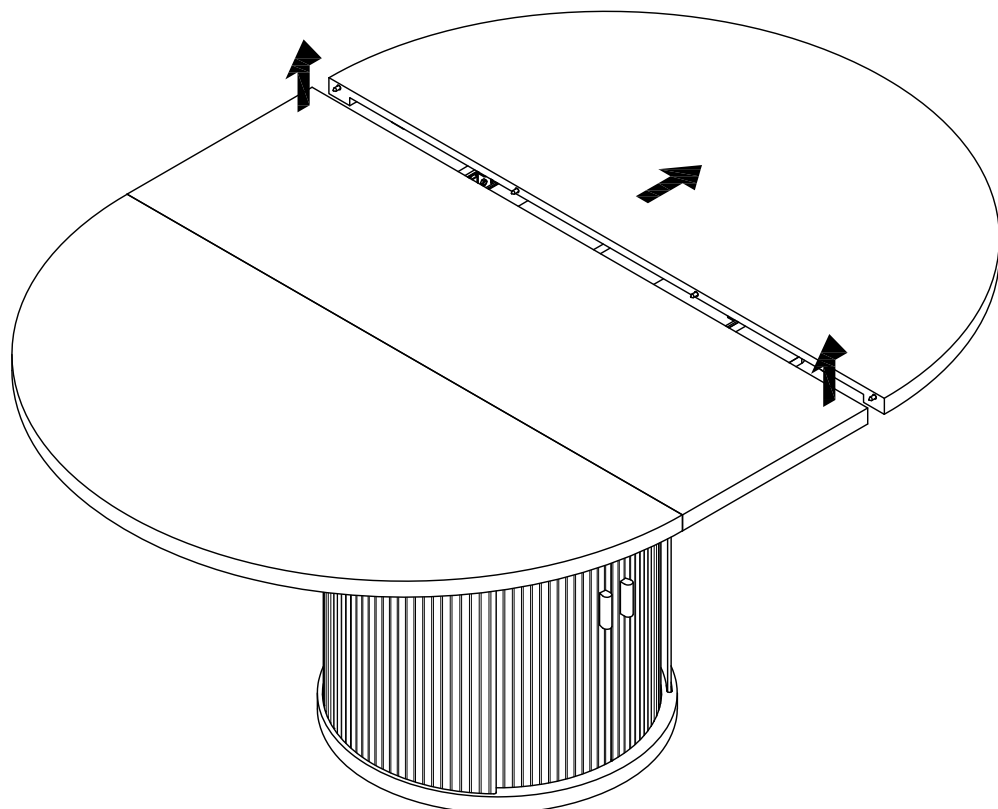
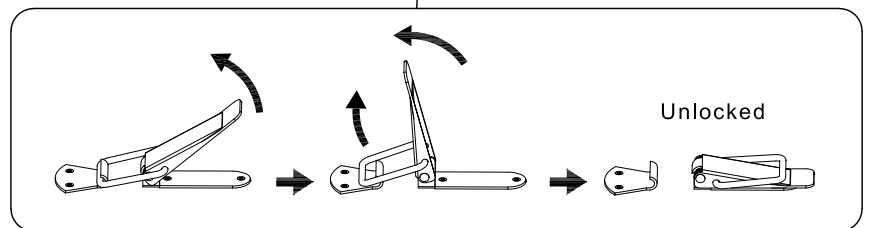
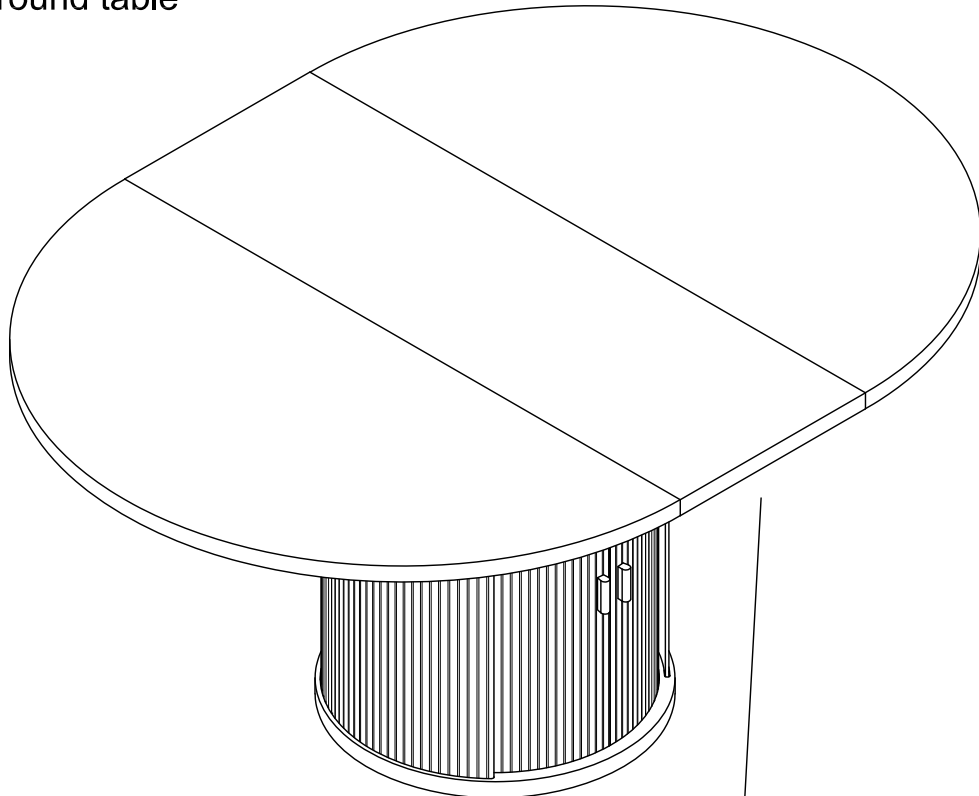

Long table to round table

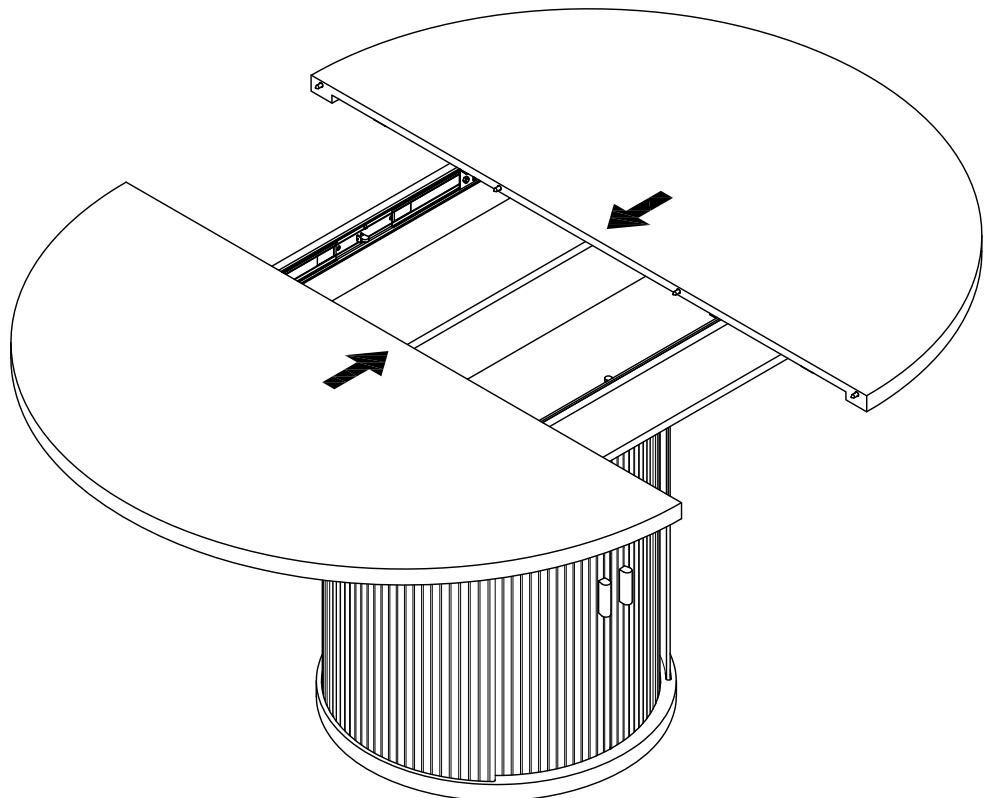
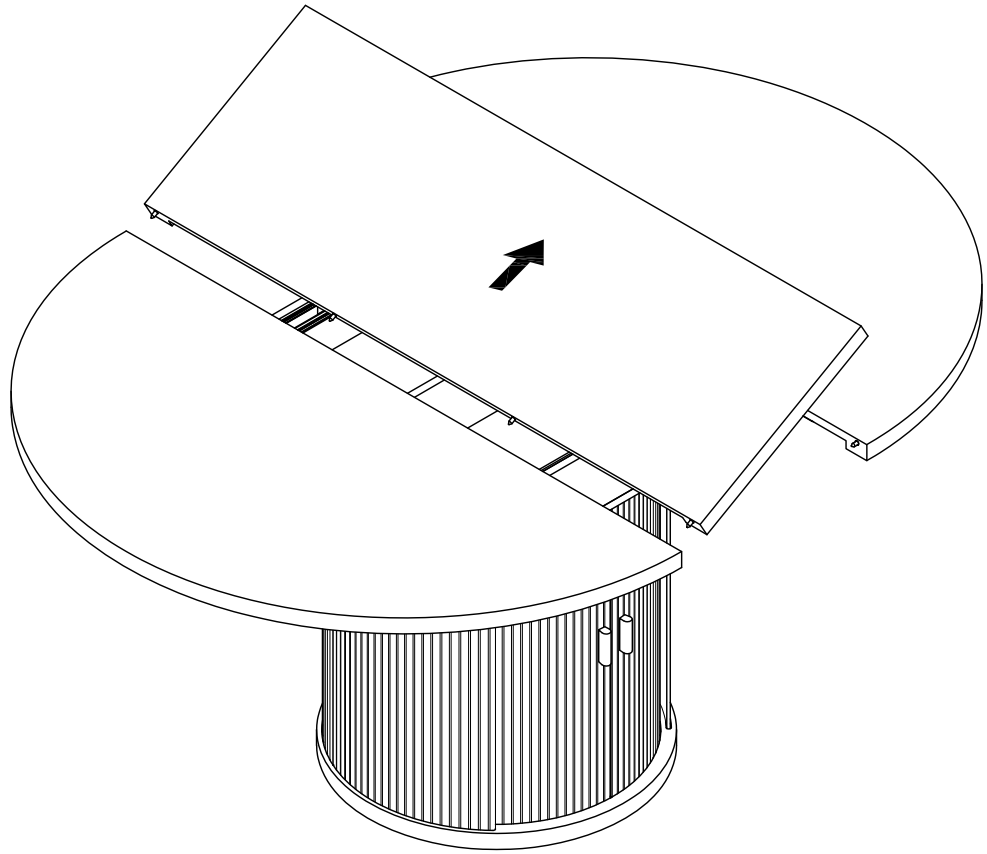

Round table

