

Wagon Stroller Instruction

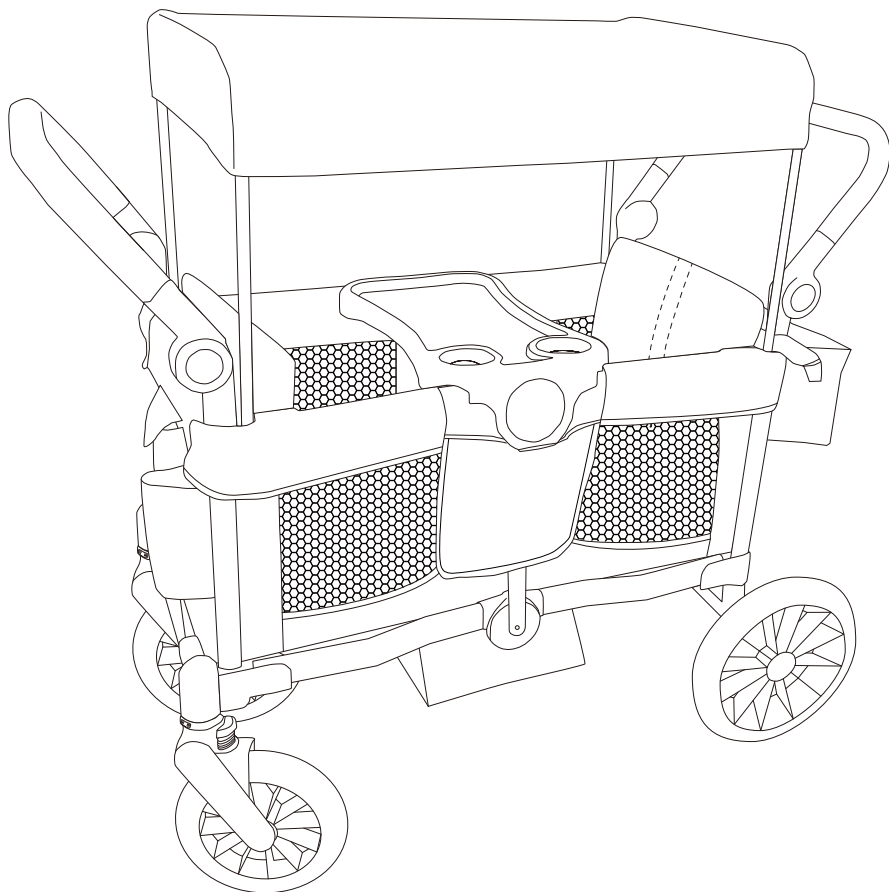

Any questions please contact us
service@replycenter.net

Usage Range: Use from 6 months up to 55 lbs per seat
Model NO.: BBA002

Read all instructions and labels before assembly and use of product.
KEEP INSTRUCTIONS FOR FUTURE USE.

IMPORTANT INFORMATION:

1. Before installing, please refer to the manual to check each part.
2. If you experience any issue during the installation, please reach out to our service team for assistance: service@replycenter.net

WARNING

READ AND FOLLOW ALL WARNINGS AND INSTRUCTIONS! FAILURE TO DO SO COULD RESULT IN SERIOUS INJURY OR DEATH!

- **NEVER** leave children unattended. **ALWAYS** keep children in view while in the product.
- Adult assembly required. Take care when unpacking and assembling; contains small parts and some items with sharp edges.
- To prevent a possible choking hazard, remove and discard packing material before using this product.
- Avoid serious injury from falling or sliding out. **ALWAYS** use waist restraint.
- **DO NOT** carry or roll product on stairs or escalators with child in it.
- **DO NOT** hang items on parent's handle or place them on the canopy as they can tip product over and injure child.
- **ALWAYS** exercise care when going over curbs or steps, and never use product for anything other than transporting your child. Use at a normal walking pace only; faster strolling can cause a loss of control and injury to the child.
- **DO NOT** place hot liquids in storage pockets. Spills can burn you or your child.
- **DO NOT** use product if any parts are missing or broken.
- **ALWAYS** apply brakes when taking children in or out.
- **DO NOT** allow child to stand on the footwell. Product may tip over and injure child.
- **DO NOT** allow child to climb on, into or out of Product unassisted.
- **DO NOT** carry additional children, goods, or accessories in or on this product except as advised in these instructions.
- The product is intended for use with one or two children and to accommodate only the additional weights in storage as listed in these instructions.
- To avoid tipping, always remove the heavier weight child from a seating position before removing the lighter weight child.
- **DO NOT** allow child to push or pull product in any mode.
- **DO NOT** allow child to sit, stand or climb over the storage basket or child's tray.
- **DO NOT** step on parent's handle.
- **DO NOT** enable easy entry when the front seat is occupied.

- **DO NOT** allow child to stand while product is in motion.
- **DO NOT** allow child to jump on seat or footwell.
- **ALWAYS** ensure product is in a fully locked position before using.
- Care must be taken when folding and unfolding product or changing handle modes to prevent finger injury to you or your child in hinge areas. Make sure child is not in the seat or near the product when folding or unfolding.
- **NEVER** leave product on a hill or incline, even with brakes set, to avoid product from tipping.
- To avoid accidental rolling, **ALWAYS** set brakes when product is not being used.
- **AVOID STRANGULATION:**
 - DO NOT** suspend strings or toys from the canopy.
 - DO NOT** place product anywhere near cords from window blinds draperies, phone, etc.
 - DO NOT** place items with a string around your child's neck such as hood strings or pacifier cords.
 - If not properly secured, the child may slip into leg openings and strangle.
- When making adjustments to the product, **ALWAYS** ensure that all parts of the body are clear of any moving parts of the product particularly when switching modes.
- The canopy is not intended to provide UV protection.
- Sharp or heavy objects placed in pockets may cause damage to the product, or injury to the child.
- The product is not suitable for running or skating.
- The product is not for children under 6 months.
- The maximum weight capacity of the tray is 4.4 lbs.
- **DO NOT** overload the tray as it can become unstable.
- The maximum weight capacity of the storage bag is 4.4 lbs.
- The maximum weight capacity of the stroller is 55 lbs for each child.
- The maximum weight capacity of the stroller in combination with any accessories is 220 lbs total.
- **DO NOT** place any child taller than 39 inches per seat in the product.
- **DO NOT** overload the product as it can become unstable.
- **ALWAYS** distribute weight as evenly as possible on each side of the product.

Cleaning

- Clean minor spills and stains on cloth or plastic surfaces with cold water and mild soap. Air dry.
- Do not use bleach.
- Metal and plastic parts can be wiped clean with a soft damp cloth and dried with a soft cloth.
- DO NOT use abrasive cleaners or solvents.
- Check that you have all parts for this model BEFORE assembling your product. If any parts are missing, please contact customer service.
- Care must be taken when folding and unfolding product or changing handle modes to prevent finger injury to you or your child in hinge areas. Make sure child is not in the seat or near the product when folding or unfolding.

Parts List

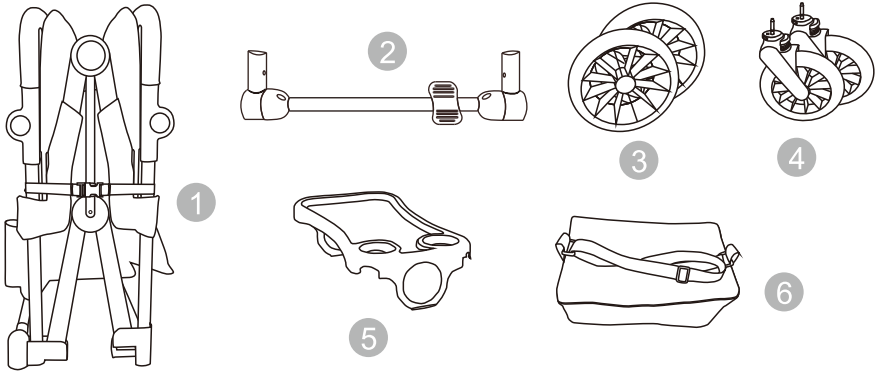

Item	Parts List	QTY
1	Wagon frame	1
2	Rear wheel bracket	1
3	Rear wheel	2
4	Front wheel	2
5	Dining tray	1
6	Storage bag	1

Install the wheels

Align the wheel posts to the stroller frame and press until you hear a click that indicating proper installation.

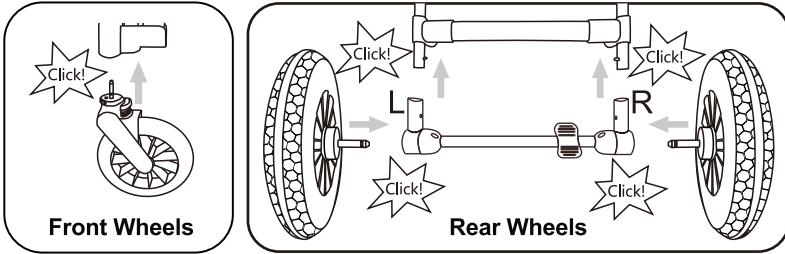

Install Rear wheel axle

When looking at the product with the handle closest to your body, there is a left and right side. Rear wheel axle are coded "L" and "R". Make sure the bottom of wagon locks in open slot in rear axle.

Unfolding wagon

Open the seat belt on the side of the wagon stroller to be able to unfold it.

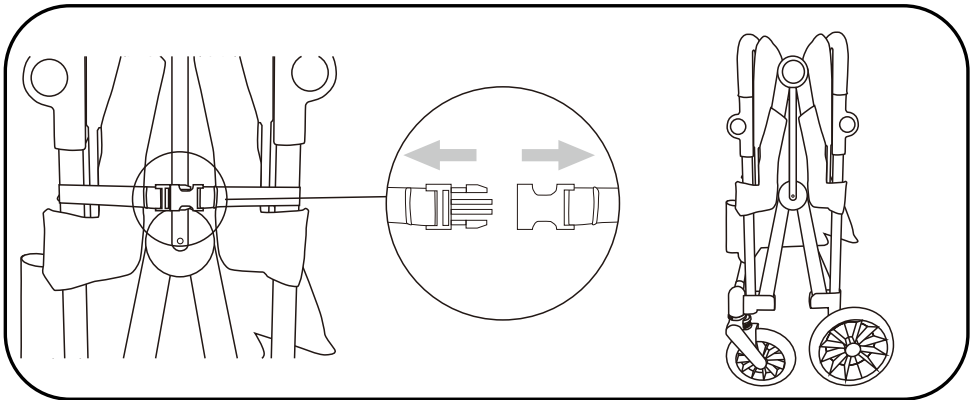

Allow the wagon to unfold out, or manually pull the wagon apart as shown in the picture, then press down on the sides of the wagon (as indicated by the arrows) until you hear a click.

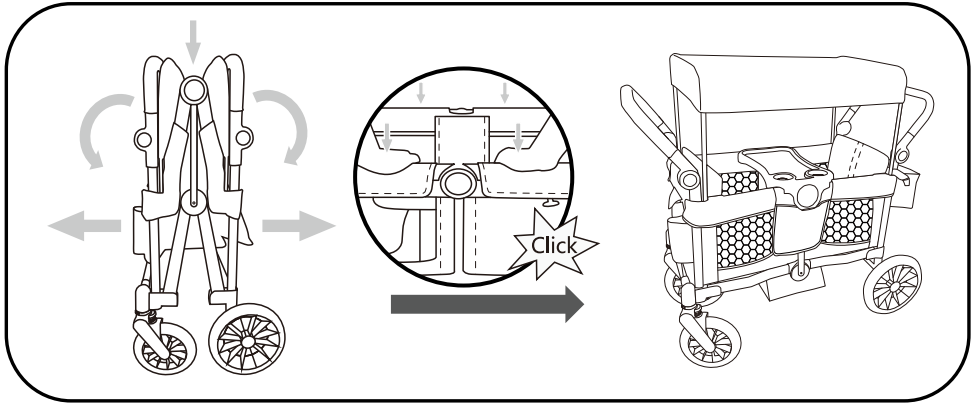

Handle Adjustment

Adjust the direction of the handle by pressing both buttons at the same time as shown.

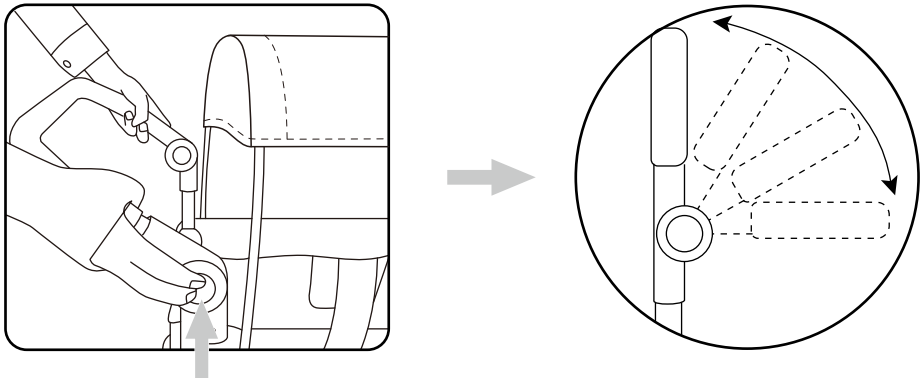

Secure frame cover to wagon frame

Secure the cover of the structure to structure by means of velcro that are found in the corners of this wrapping tube. Velcro do the same to each other of the wagon stroller.

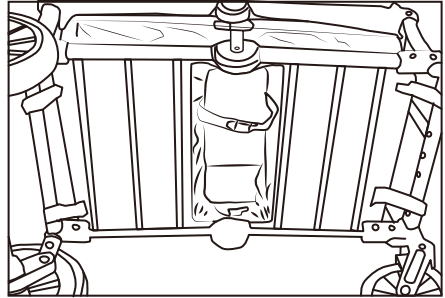

Secure the seat back to the seat cover

There is a zipper on the back of the seat cushion, please make sure the zipper is tight to prevent the seat cushion from sliding out easily.

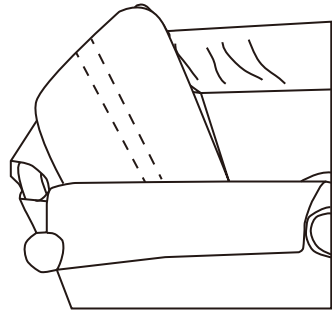

Install the tray

- Align the sides of the tray with slots sides of the stroller and slide it down until that it fits correctly in the stroller.
- To remove it, press the buttons on both sides and pull upwards.

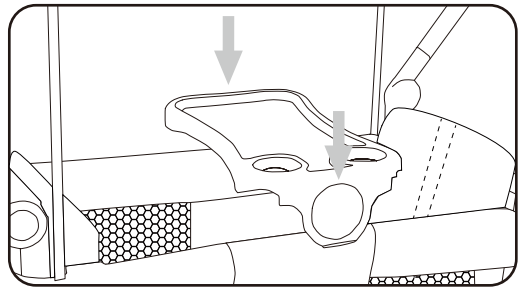

Use of brakes

 To activate the brakes, press the front of the lever brake as shown in picture.

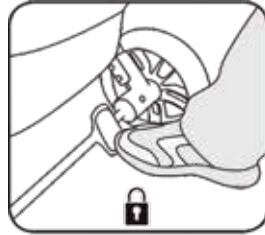

 To deactivate the brakes, lift the front of the lever brake as shown in the picture.



Use of the safety harness

Push the canopy to one side and remove the food tray. Please fasten the 5-point harness for safety after your child sit in the stroller.

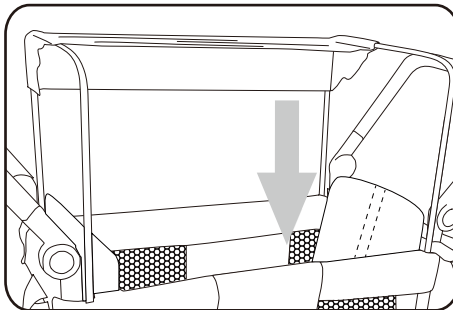
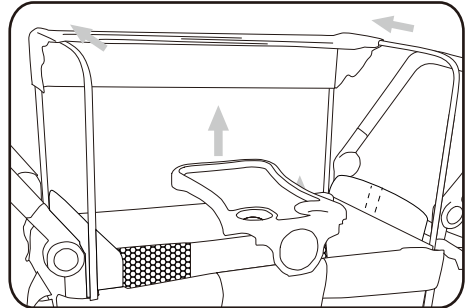

Use of the Storage bag

When securing the storage bag to the carhandle, it is necessary to remove the long strap from the storage bag .

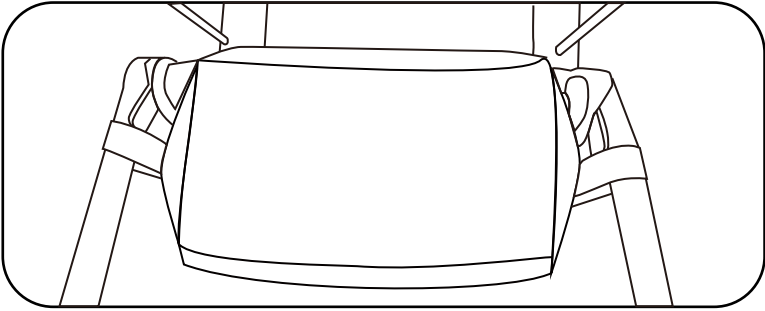

Long hanging belt is only used when hanging the storage bag on the body for adults .

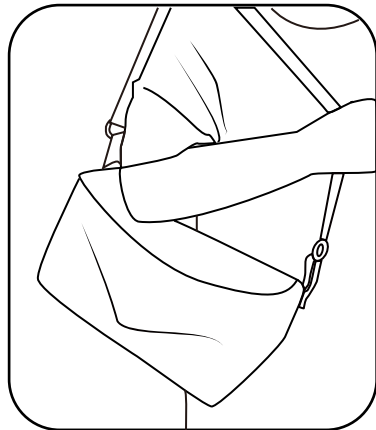

⚠️ WARNING

- Avoid serious injury or death from falling or sliding out. ALWAYS use child restraint system.
- NEVER leave children unattended. ALWAYS keep children in view while in the product.
- The product is intended for use with one or two children.
- After fastening safety harness, adjust safety harness to that they perfectly secure your child. Straps must be positioned exactly as shown.
- Place your child in the wagon stroller, with the crotch strap between the child's legs. Fasten the belt and fasten both buckles. Adjust the waist strap, comfortably around your child.

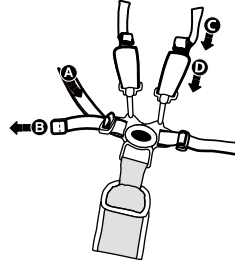
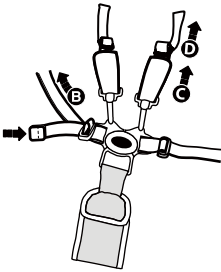

Adjusting canopy

Adjust and pull the canopy to the appropriate position.

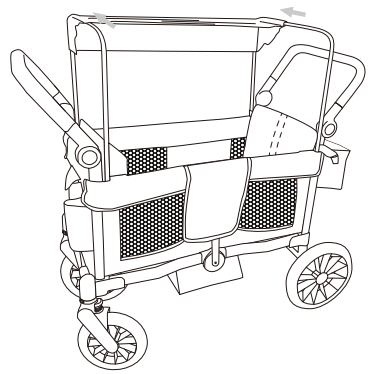
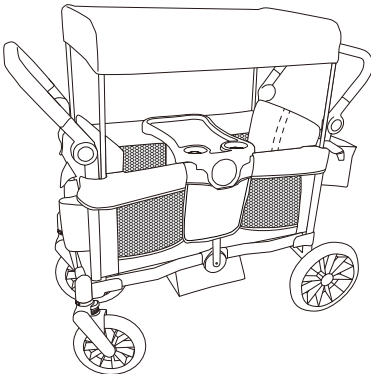

How to fold the Wagon Stroller

STEP 1 >

Remove dining tray and flip two side organizer pockets inside the stroller.

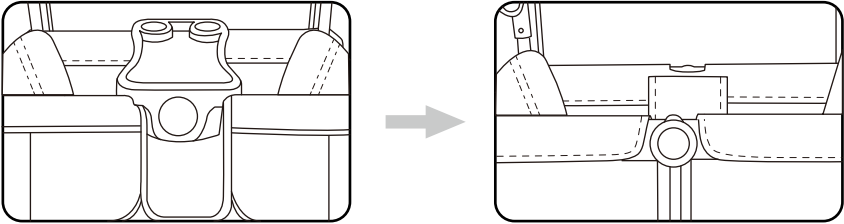

STEP 2 >

Two handles should be adjusted by pressing the adjustment button to adjust the handle as shown.

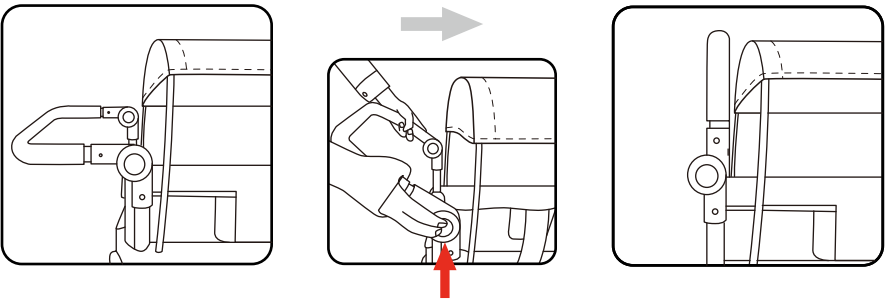

STEP 3 >

Place the interior foot rest flush with the baby seat.

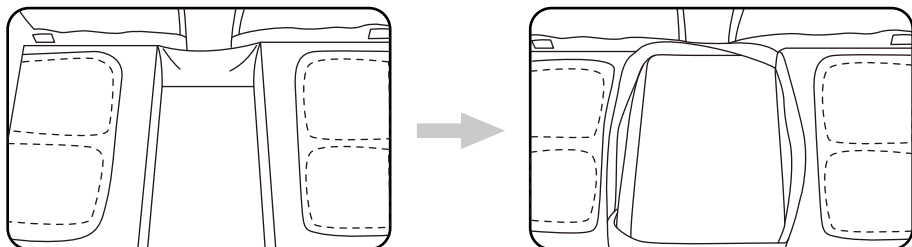

STEP 4 >

Press the buttons on both sides of the stroller and lift up as shown in the picture.

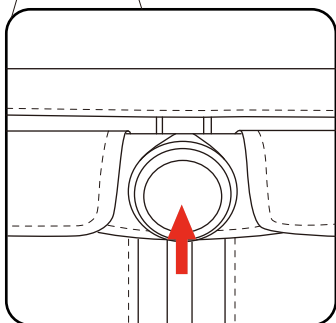
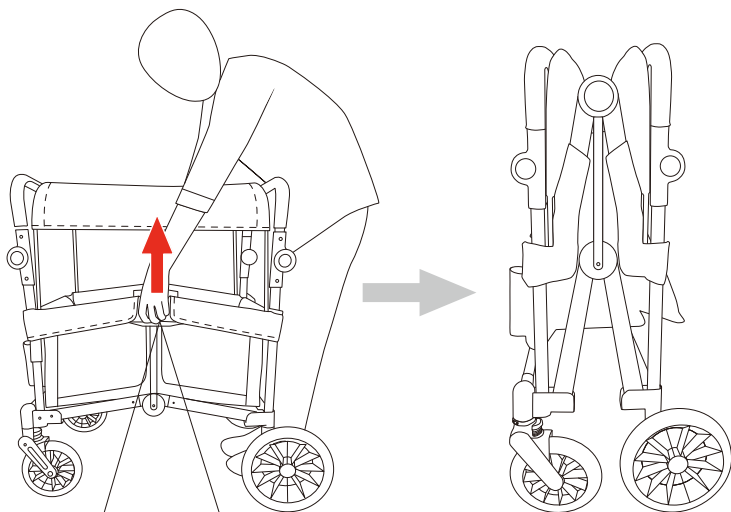

Note: Both side buttons should be pressed at the same time.

STEP 5 >

Fasten the seat belt on the side of the wagon and hear a click.

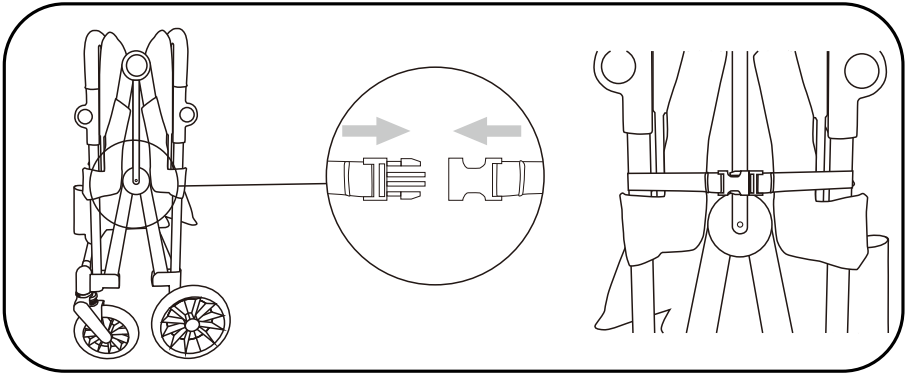

AFTER-SALE SERVICE

If you have any suggestions for our products or find that the products have quality problems, please contact us first, our after-sales team will reply you within 24 hours, and we will do our best to give you solutions until you are satisfied.

Guaranteed Customer Service

Your shopping experience is very important to us!
Feel unsatisfied? **Contact us!**
Have any questions? **Contact us!**

Wanna share your experience with our products?
Share your pictures with us.

Any suggestions? **Contact us!**
We gotcha back!



E-mail: service@replycenter.net