

Weight capacity : 75 kgs/ 165 Lbs

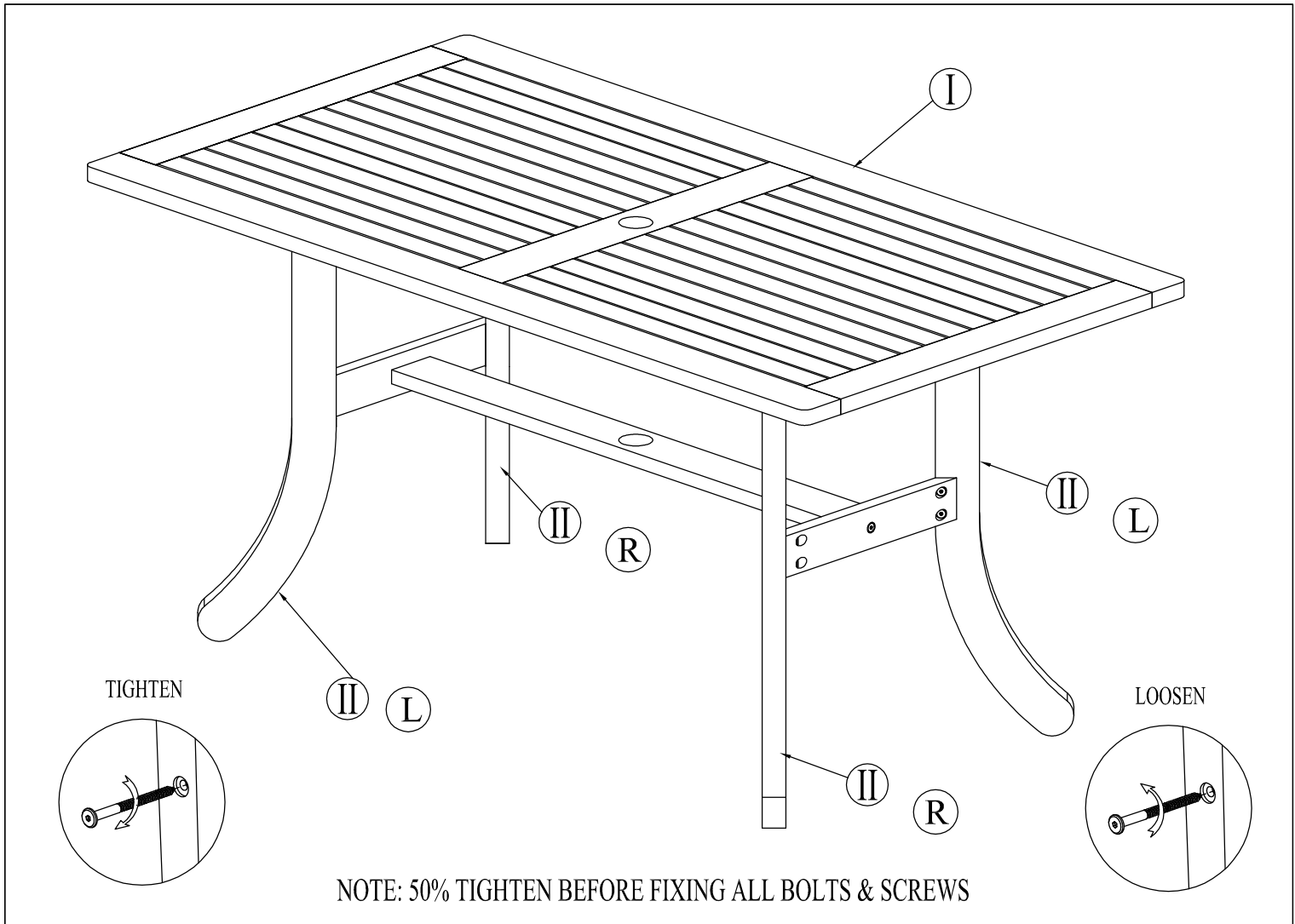

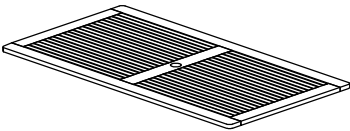

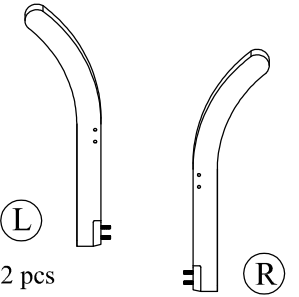

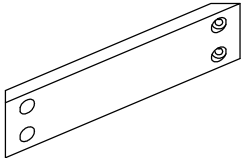
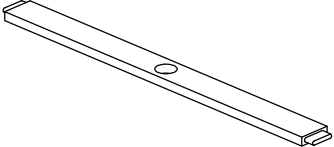

### COMPONENTS LIST

 <p>Q'TY 1</p>	 <p>2 pcs</p> <p>Q'TY 4</p>	 <p>Q'TY 2</p>	 <p>Q'TY 1</p>
--	--	--	---

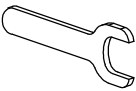
### HARDWARE LIST

A		2	Screw 7 x 60	D		8	Washer
B		8	Screw 7 x 40	E		1	Spanner
C		8	Nut M8	F		2	Allen Key

# Step 1

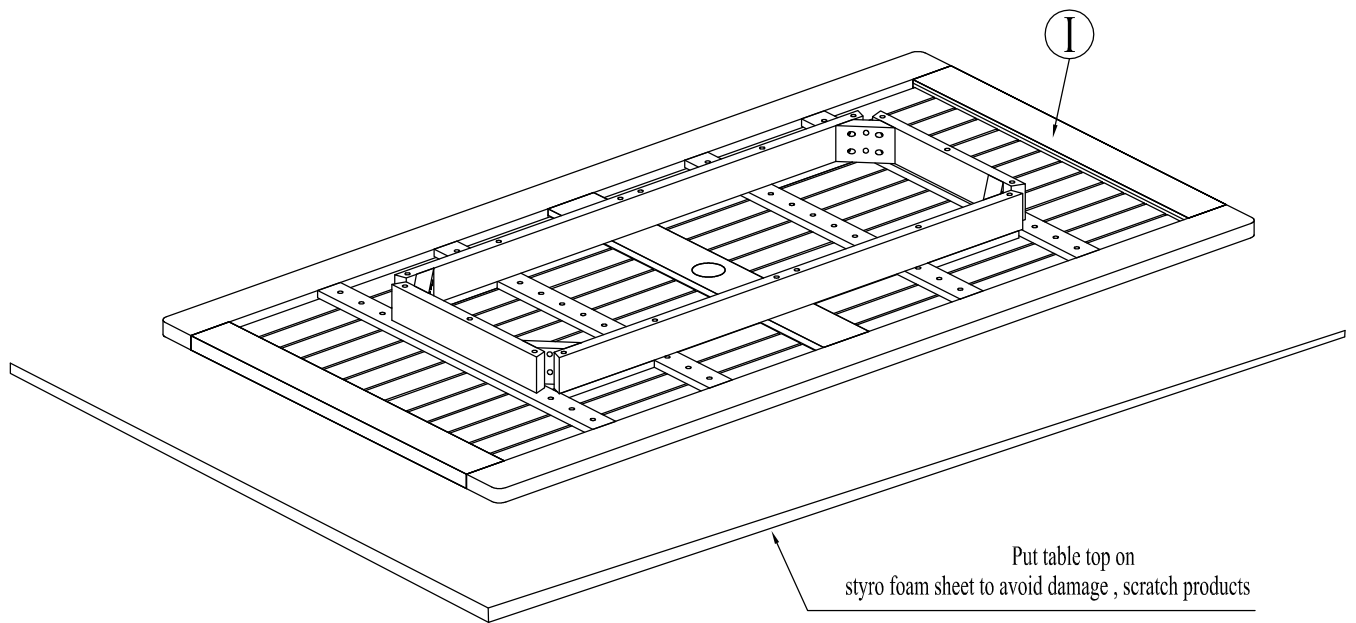

# Step 2

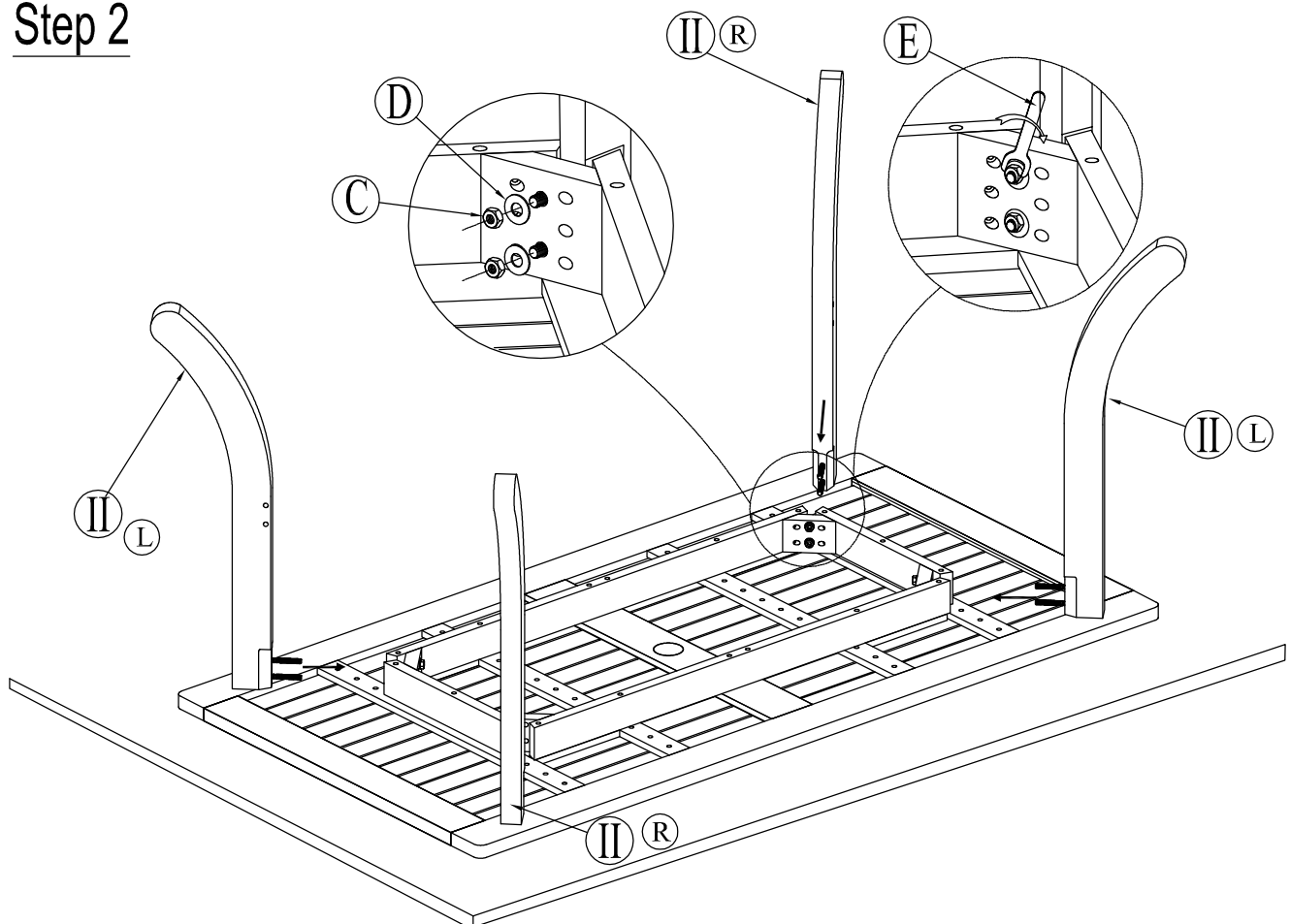

### Step 3

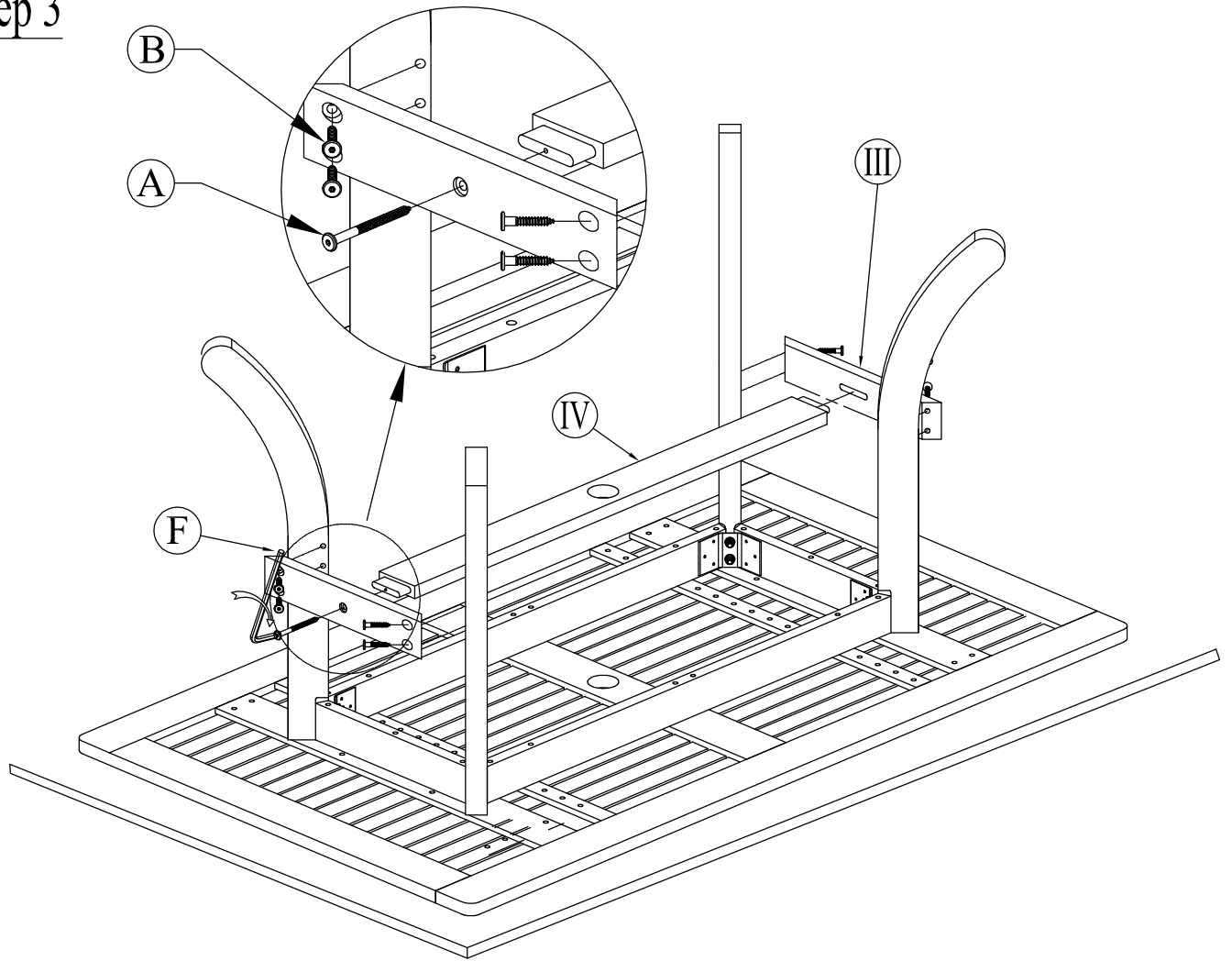

### Step 4

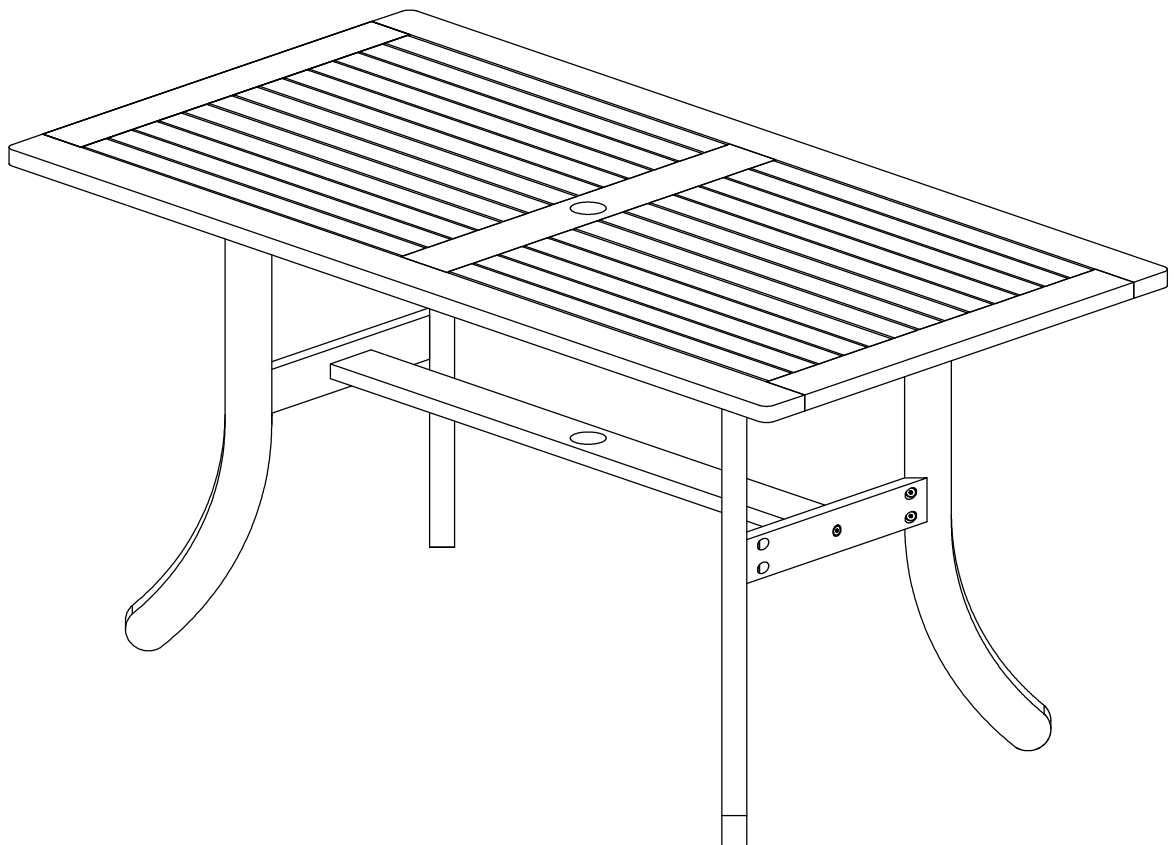

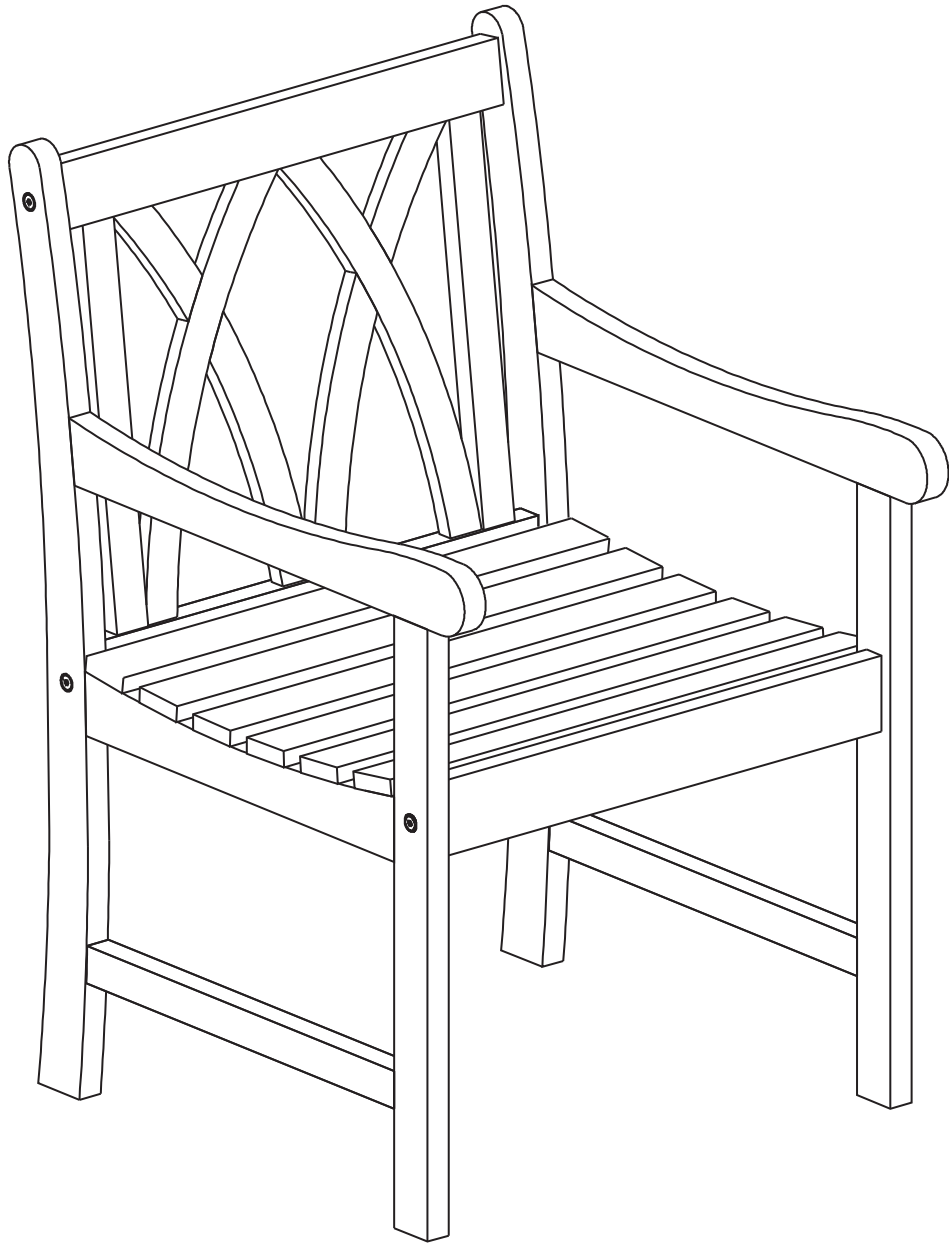

Maximum capacity : 110 kgs/242 Lbs



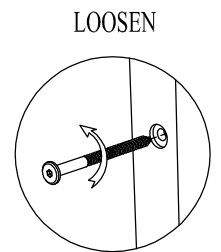
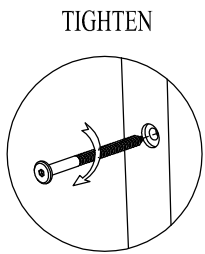
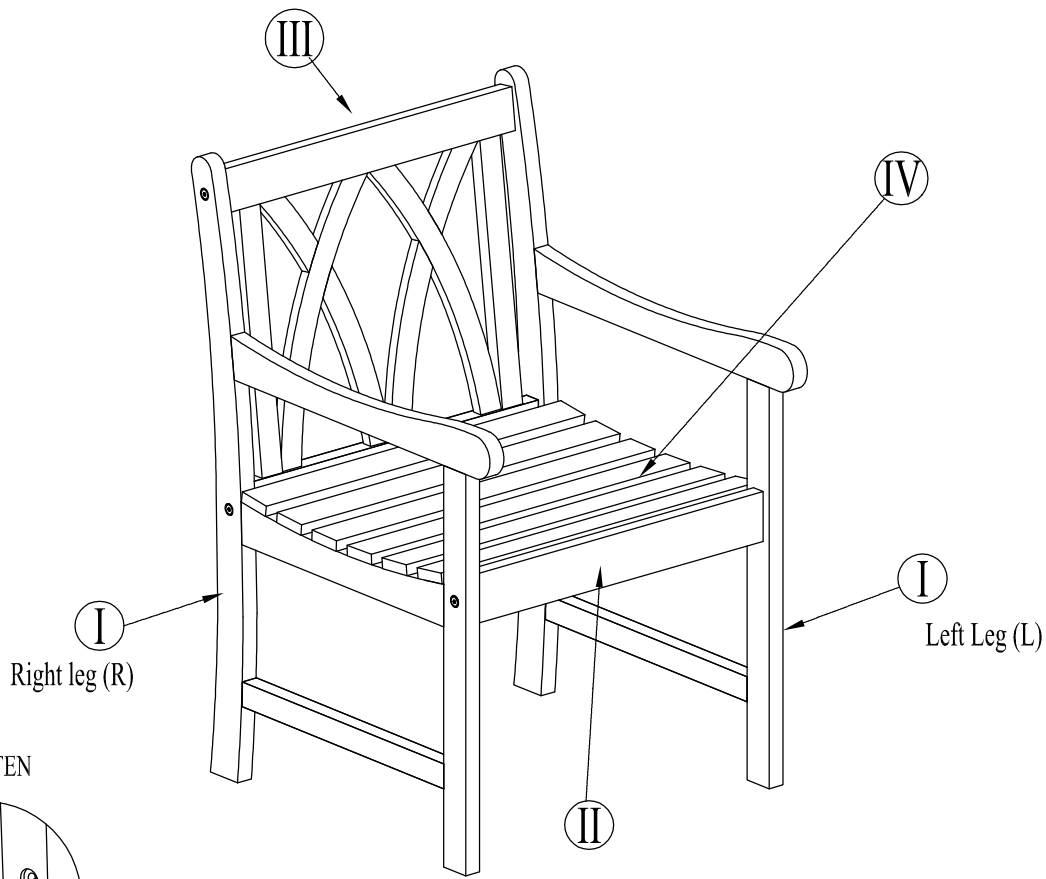

NOTE: 50% TIGHTEN BEFORE FIXING ALL BOLTS & SCREWS

### COMPONENTS LIST

<p>Right leg (R)      Left Leg (L)</p> <p>Q'TY 2</p>	<p>Q'TY 1</p>	<p>Q'TY 1</p>
<p>Q'TY 1</p>		

### HARDWARE LIST

A		6	Screw 7 x 70				
B		2	Screw 7x40	C		2	Allen Key

# Step 1

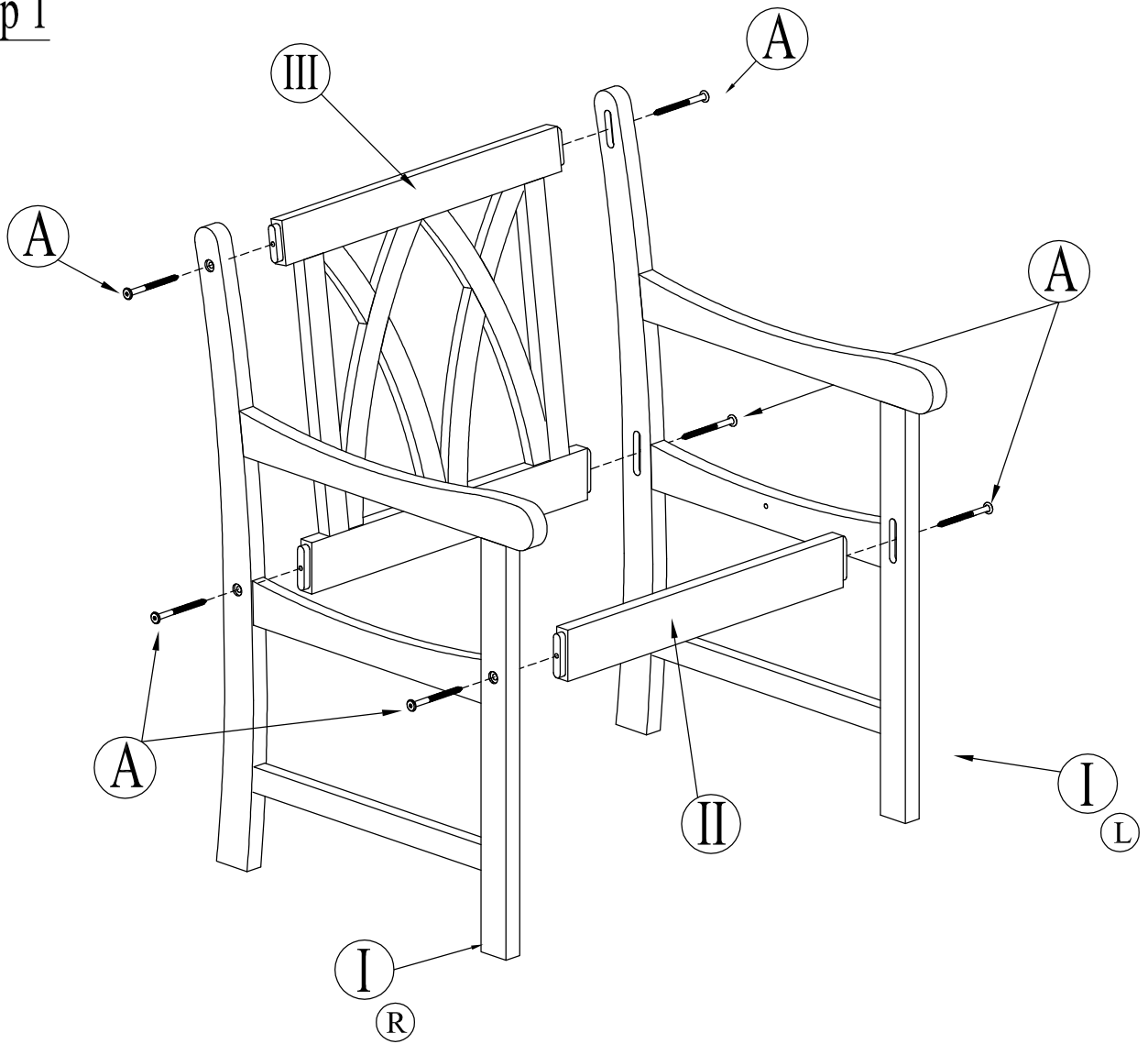

# Step 2

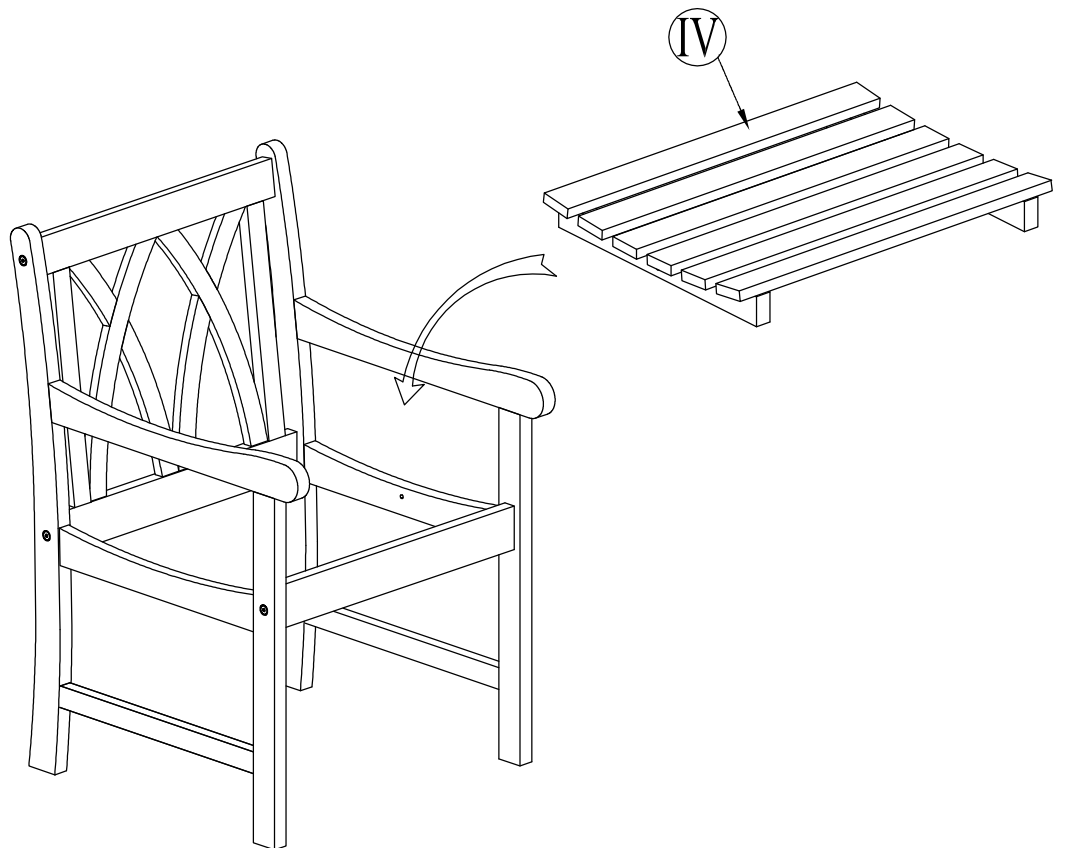

### Step 3

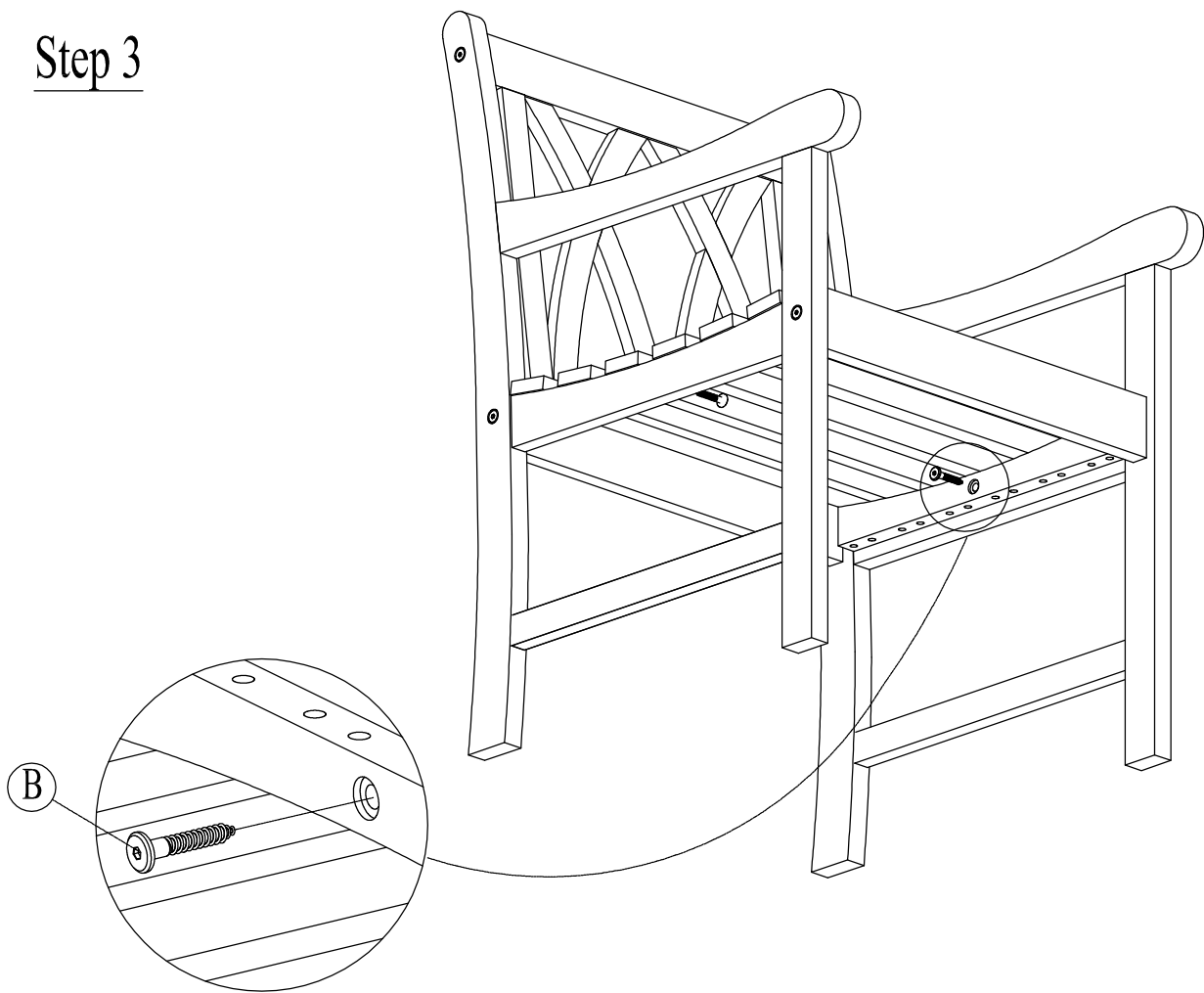

### Step 4

