

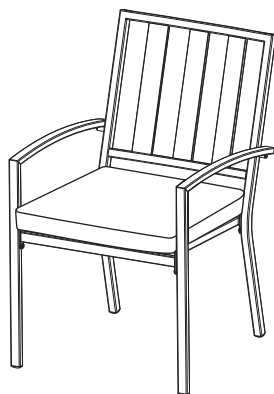

Assembly Instructions
Instructions de montage
Instrucciones de montaje

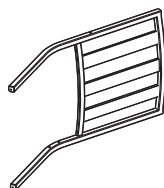

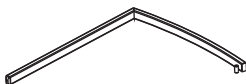
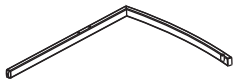

Chair

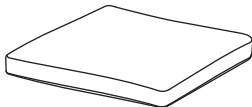

Parts List-Liste des pieces-Lista de partes

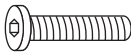
NO.	Picture	Description	Qty
A		Backrest Panel	1
B		Right Arm Panel	1
C		Left Arm Panel	1
D		Seat Panel	1
E		Seat cushion	1

Hardware-Matériel-Hardware

NO.	Picture	Description	Qty
F		Bolt (6.35 MM X 20 MM)	8
G		Bolt (6.35 MM X 35 MM)	2
H		Washer (Ø6.5 X 1.0 MM)	8
I		Washer (Ø12 X Ø6.5 X 1.0 MM)	2
J		Hex Bolt Driver	1

Assembly Preparation-Preparación de montaje-Preparación de montaje

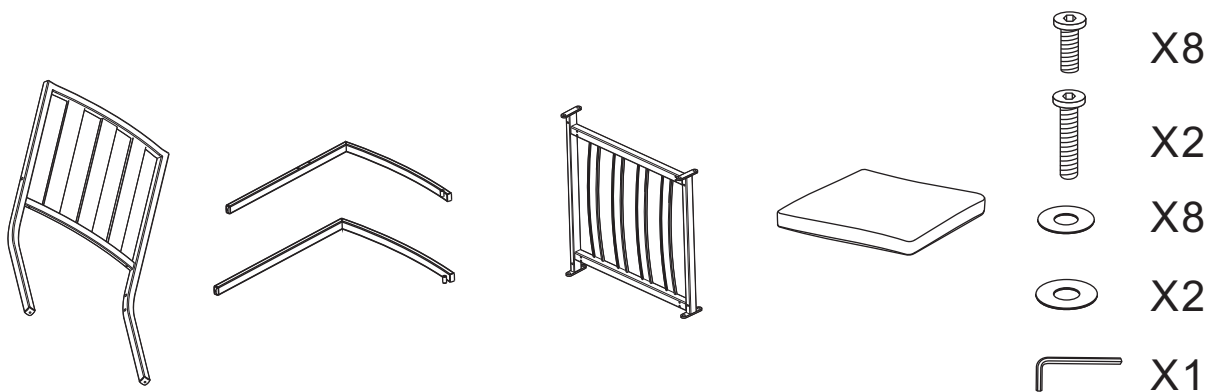

DO NOT FULLY TIGHTEN BOLTS UNTIL THE ITEM IS FULLY ASSEMBLED.

NE SERREZ PAS COMPLÈTEMENT LES BOULONS JUSQU'À CE QUE L'ARTICLE SOIT COMPLÈTEMENT ASSEMBLÉ.

NO APRIETE COMPLETAMENTE LOS PERNOS HASTA QUE EL ARTÍCULO ESTÉ COMPLETAMENTE MONTADO.

Assembly Steps-Étapes d'assemblage-Pasos de montaje

Overview

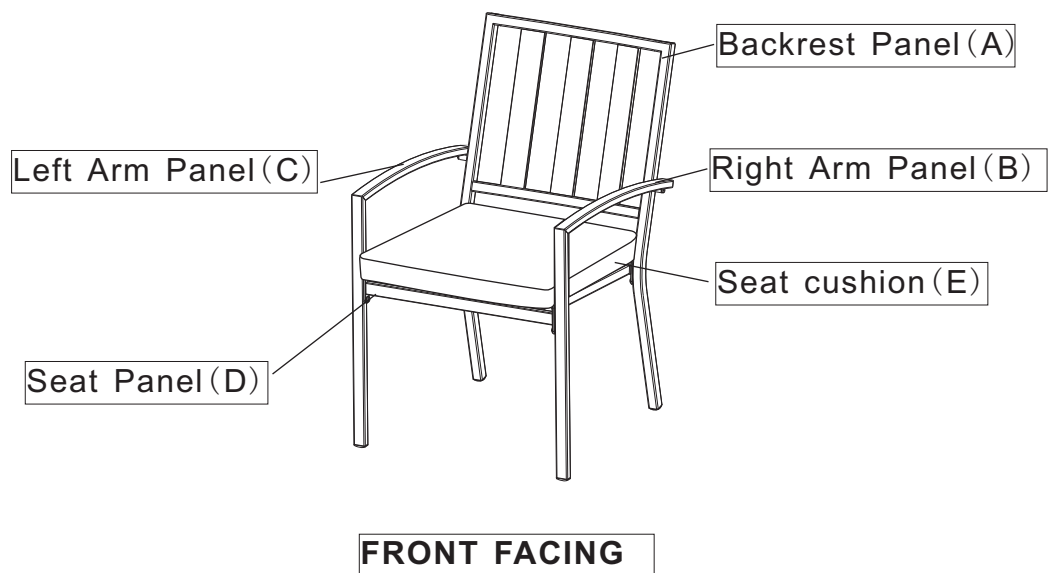

Step 1

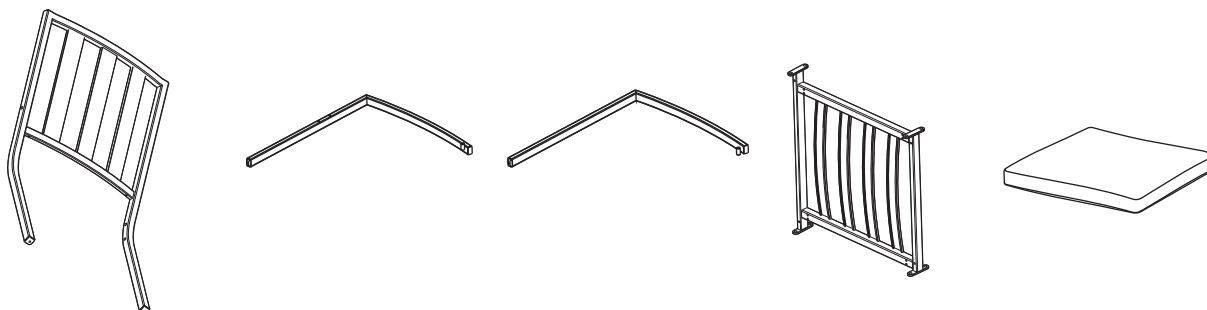

Step 2

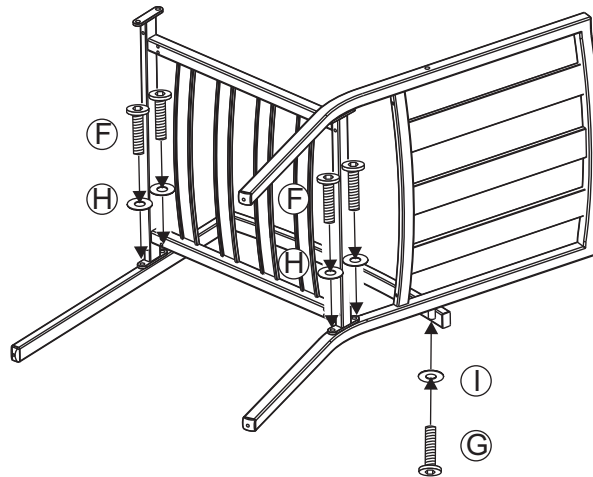

Step 3

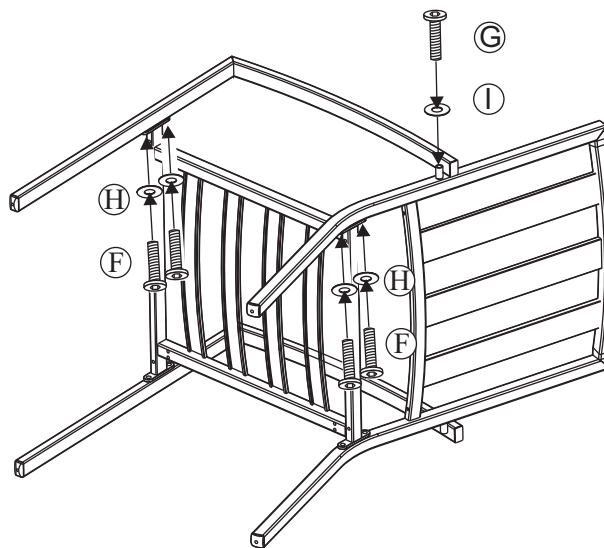

DO NOT FULLY TIGHTEN BOLTS UNTIL THE ITEM IS FULLY ASSEMBLED.

NE SERREZ PAS COMPLÈTEMENT LES BOULONS JUSQU'À CE QUE L'ARTICLE SOIT COMPLÈTEMENT ASSEMBLÉ.

NO APRIETE COMPLETAMENTE LOS PERNOS HASTA QUE EL ARTÍCULO ESTÉ COMPLETAMENTE MONTADO.

Step 4

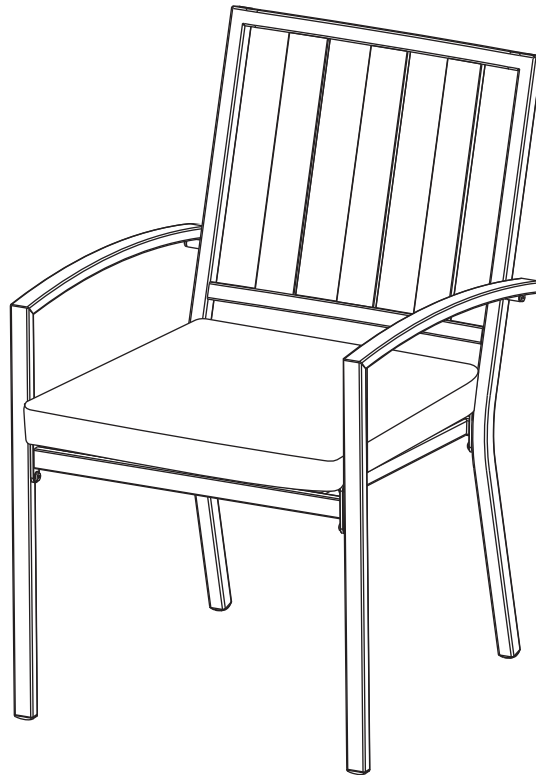

DO NOT FULLY TIGHTEN BOLTS UNTIL THE ITEM IS FULLY ASSEMBLED.

NE SERREZ PAS COMPLÈTEMENT LES BOULONS JUSQU'À CE QUE L'ARTICLE SOIT COMPLÈTEMENT ASSEMBLÉ.

NO APRIETE COMPLETAMENTE LOS PERNOS HASTA QUE EL ARTÍCULO ESTÉ COMPLETAMENTE MONTADO.