

Instruction Manual

8-inch wooden base slicer

Product Schematic diagram

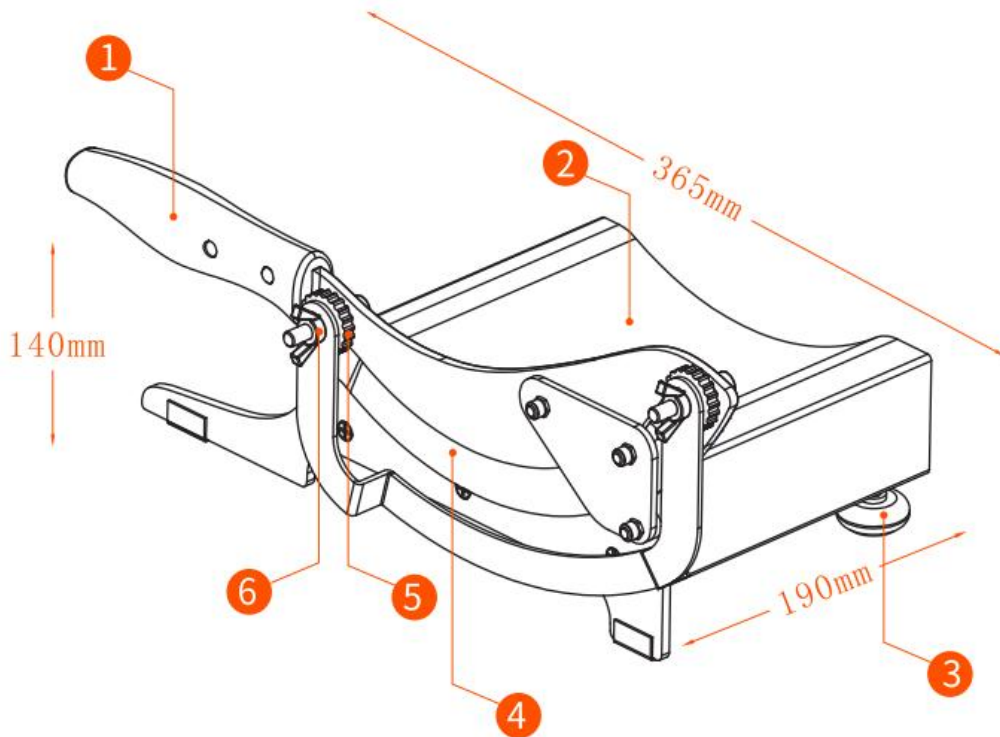

1.Handle
4.Up blade

2. Wooden body
5. Black nut

3. Anti-slip foot pad
6. Wing nut

Machine maintenance

When not in use for a long time, please use a dry cloth to wipe water marks on the body and parts, and give the shaft, Nuts, fuselage, baffle and other parts are smeared with anti-rust oil (can be replaced by vegetable oil). The thickness baffles are best to be removed and stored in a cool and dry place.

Instructions

- 1.Place the slicer on a smooth and clean flat workbench and confirm that it is stable;
- 2.Place the food to be processed in the corresponding cutting area of the fuselage workbench, and adjust the distance between the thickness baffle and the blade by screwing in and out of the 2 black nuts, so as to achieve the purpose of controlling the thickness of the slice;
- 3.Lift the knife handle by hand until the blade is just above the height of the food material, and push the food material in the direction of the thickness baffle until it resists the thickness baffle;
- 4.Hold the knife handle tightly with your hand, hold the food with your left hand, press the knife handle down to complete a slicing action, repeat the action to complete the operation.

Thickness adjustment instructions

- 1.Unscrew the two wing nuts on the thickness baffle counterclockwise, remove the thickness baffle, and unscrew the two black nuts;
- 2.Use the matching wrench to unscrew the two short screws counterclockwise, then screw in the two long screws clockwise, and turn them to a reasonable position according to the required thickness;
- 3.Then install and tighten the black nut, thickness baffle, and wing nut in turn.