

ASSEMBLY INSTRUCTIONS



COFFEE TABLE

ASSEMBLY INSTRUCTIONS

ASSEMBLY TIPS:

1. Remove hardware from box and sort by size.
2. Please check to see that all hardware and parts are present prior to start of assembly.
3. Please follow attached instructions in the same sequence as numbered to assure fast & easy assembly.



WARNING!

1. Don't attempt to repair or modify parts that are broken or defective. Please contact the store immediately.
2. This product is for home use only and not intended for commercial establishments.



ASSEMBLY TIME

60 MINUTES

PARTS IDENTIFICATION

A LEFT SIDE PANEL 1 PC

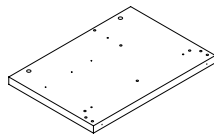

B RIGHT SIDE PANEL 1 PC

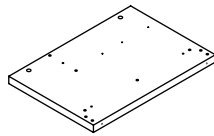

C MIDDLE DIVIDER PANEL 1 PC

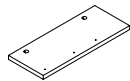

D LOWER CROSS BRACE 2 PCS

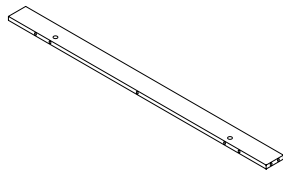

E BOTTOM PANEL 1 PC

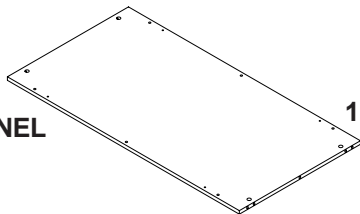

F BACK PANEL 1 PC

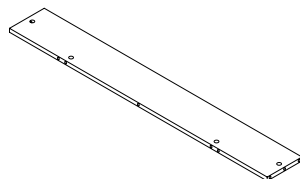

G TOP PANEL 1 PC

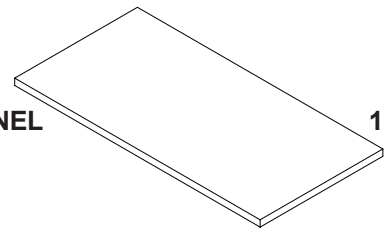

H LEFT DRAWER FRONT PANEL 1 PC

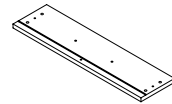

I RIGHT DRAWER FRONT PANEL 1 PC

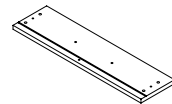

J DRAWER LEFT SIDE PANEL 2 PCS

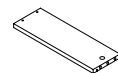

K DRAWER RIGHT SIDE PANEL 2 PCS

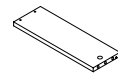

L DRAWER BOTTOM SUPPORT 2 PCS

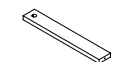

NOTE:

Phillips head screw driver is required in the assembly process; however, manufacturer does not provide this item.

M **DRAWER
BACK PANEL**

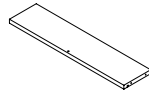

2 PCS





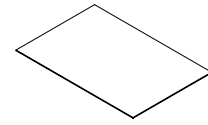



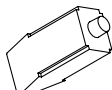

N

**DRAWER
BOTTOM PANEL**

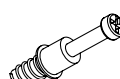
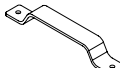

2 PCS

HARDWARE IDENTIFICATION

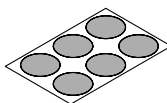
Z							
NO	DESCRIPTION	FIGURE	Q'TY	NO	DESCRIPTION	FIGURE	Q'TY
1	GLUE 40g		1 PC	7	RAIL L = 350mm BLK		2 SET
2	WOODEN DOWEL Ø8x30mm		43 PCS	8	SCREW Ø3x10mm BLK		24 PCS
3	CAM BOLT Ø7x35.5mm SR		24 PCS	9	HANDLE BLK		2 PCS
4	CAM LOCK Ø15x12mm SR		24 PCS	10	HANDLE BOLT M5x25mm BLK		4 PCS
5	SCREW Ø4.3x35mm SR		10 PCS	11	NUT M5		4 PCS
6	PLASTIC FEET Ø15mm		6 PCS	12	STICKER Ø20mm		4 PCS

Z7,Z9,Z10,Z11 not included in blister packaging.

NOTE:

Phillips head screw driver is required in the assembly process; however, manufacturer does not provide this item.

STEP 1

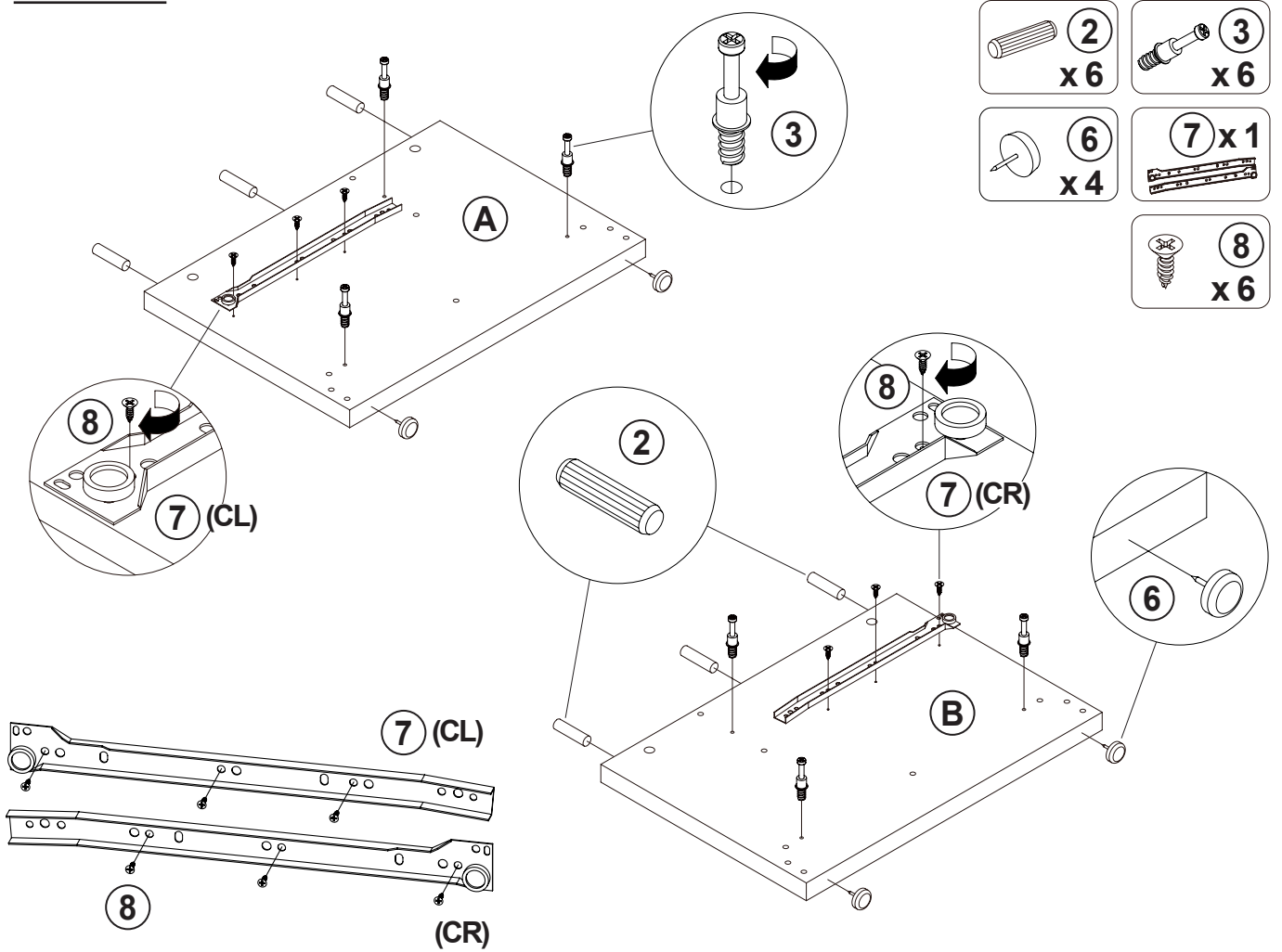

STEP 2

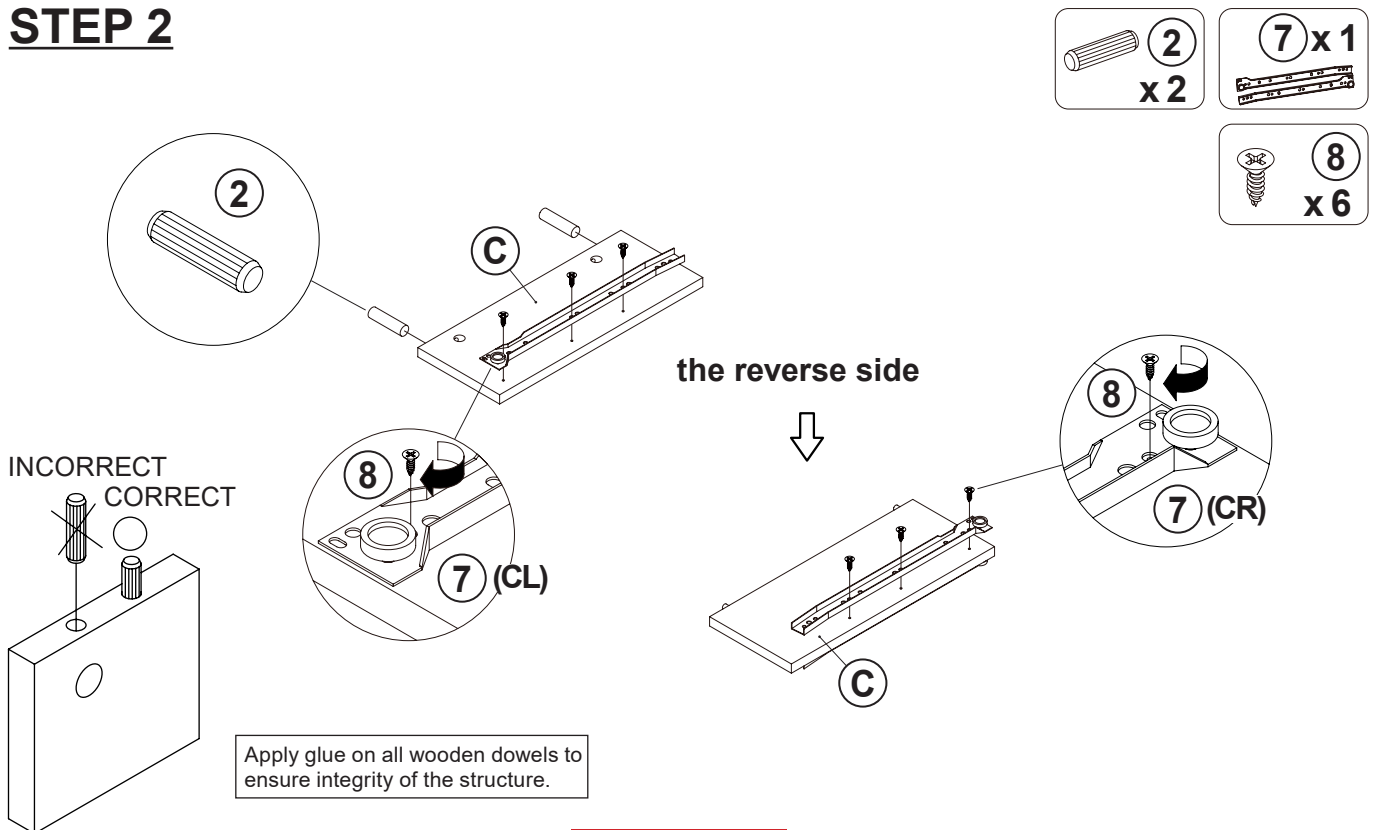

STEP 3

2
x 27

3
x 12

6
x 2

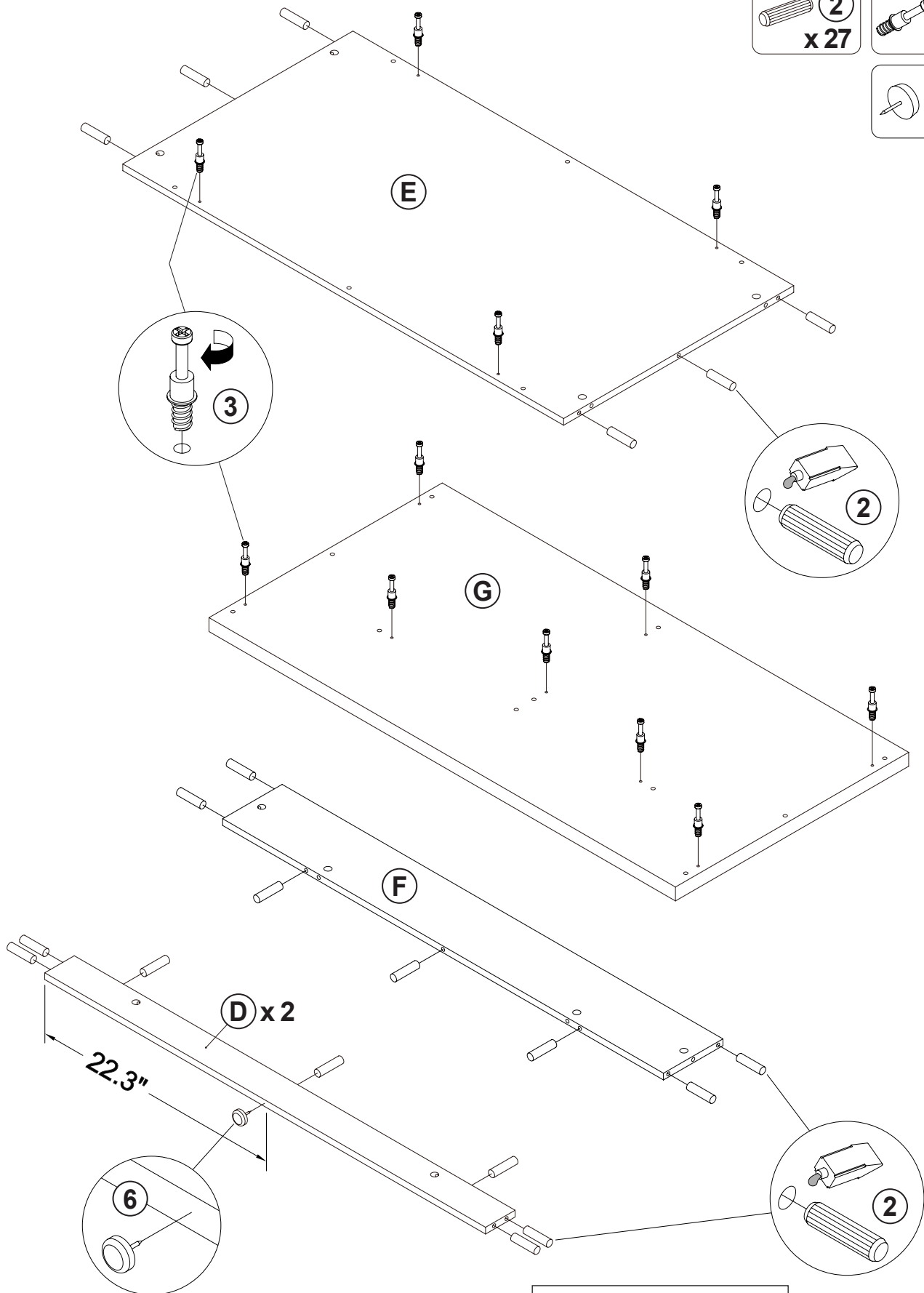

Apply glue on all wooden dowels to ensure integrity of the structure.

STEP 4

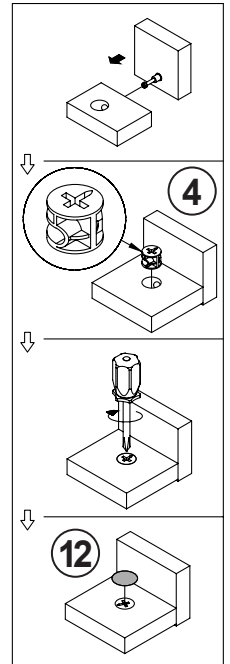
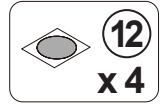
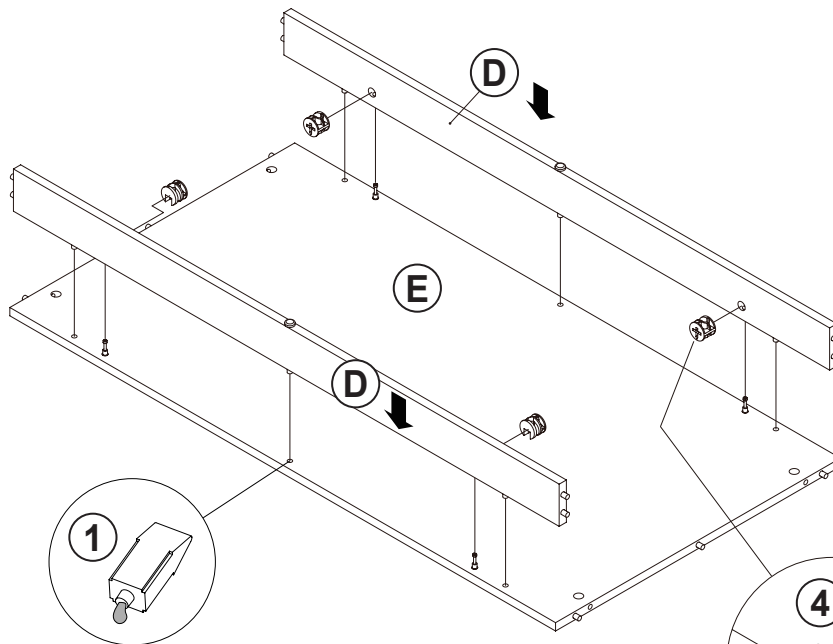

STEP 5

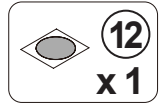
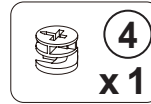
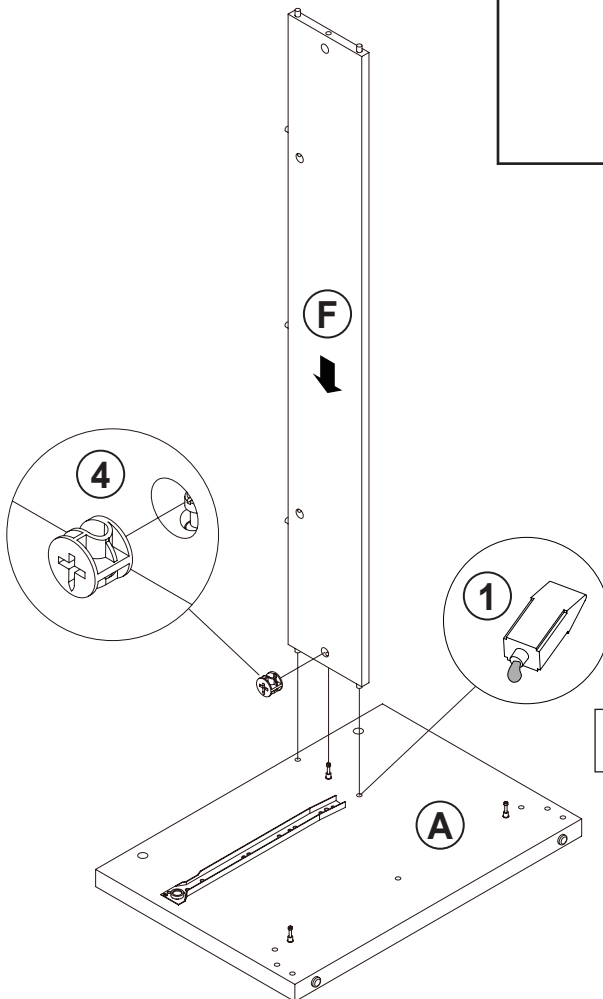

Apply glue on all wooden dowels to ensure integrity of the structure.

STEP 6

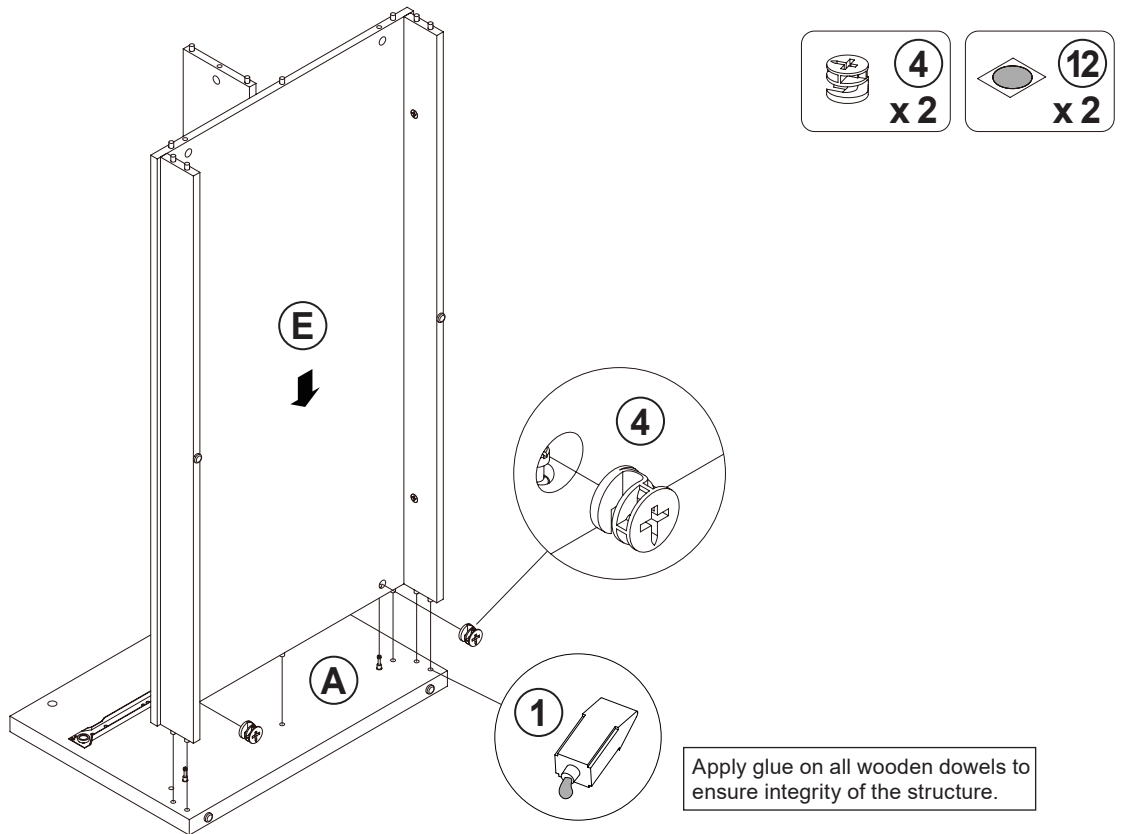

STEP 7

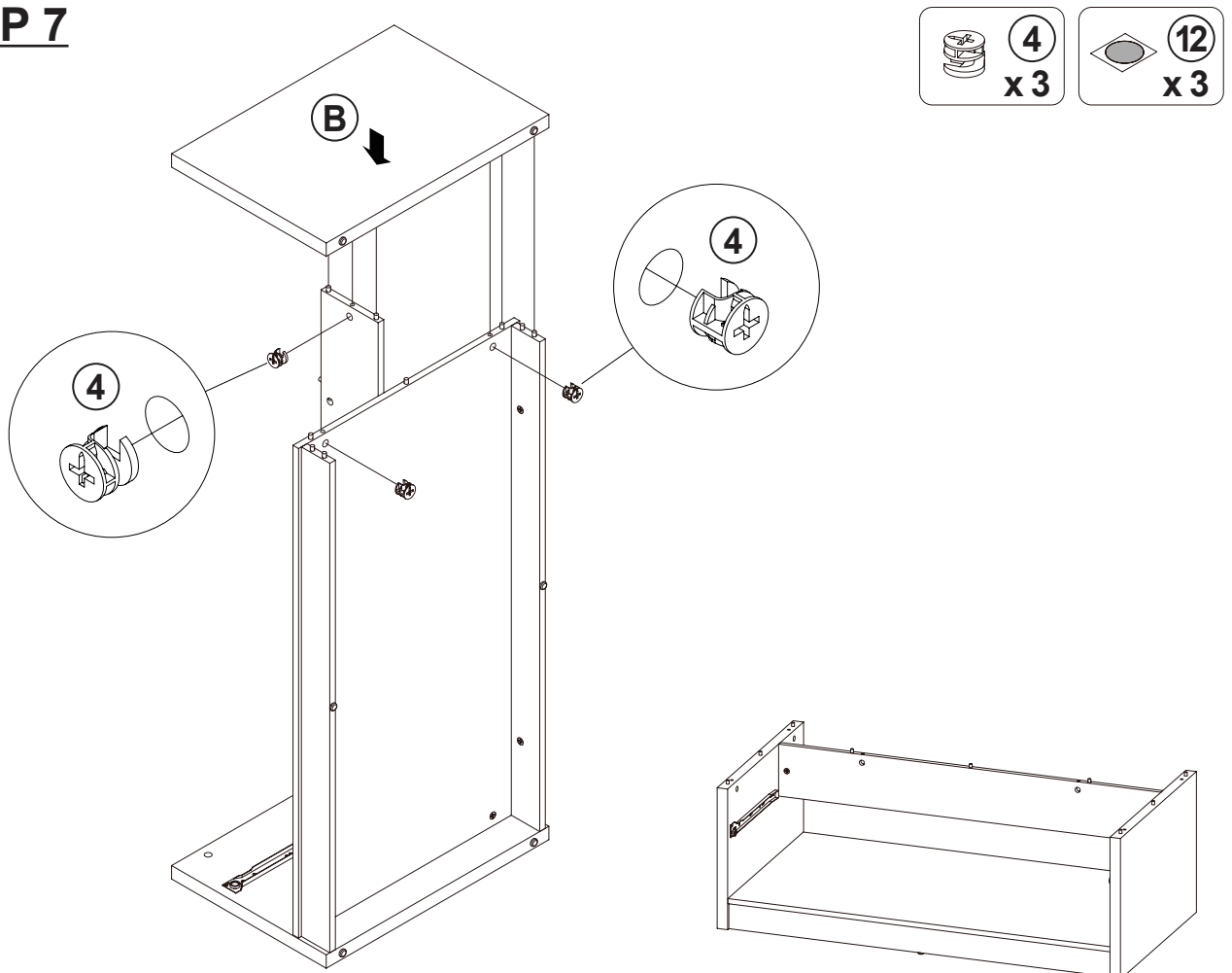

STEP 8

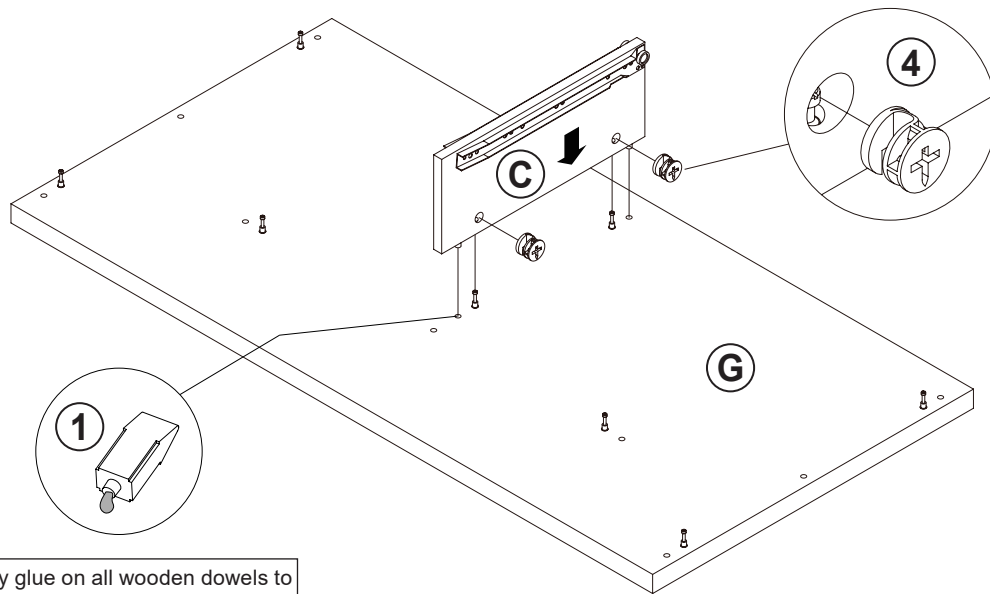
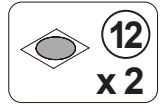

Apply glue on all wooden dowels to ensure integrity of the structure.

STEP 9

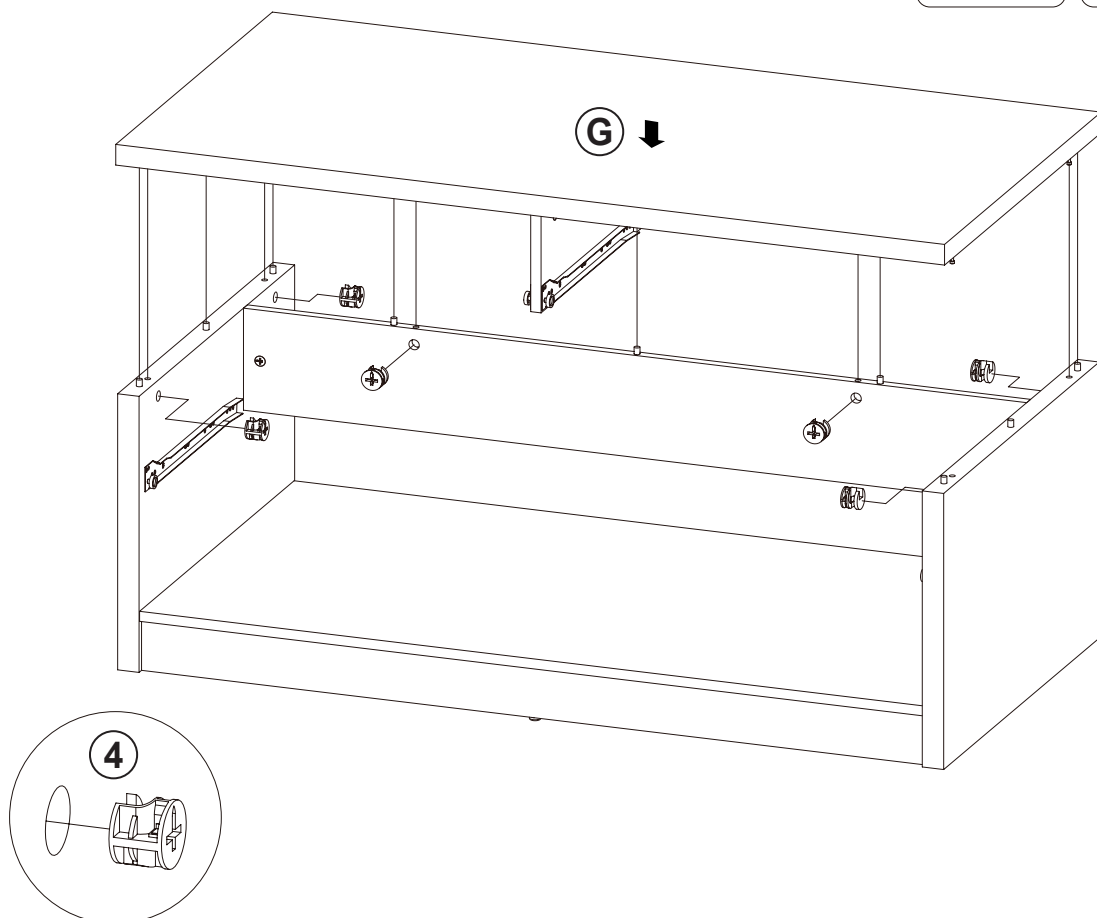
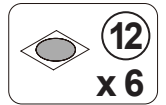

STEP 10

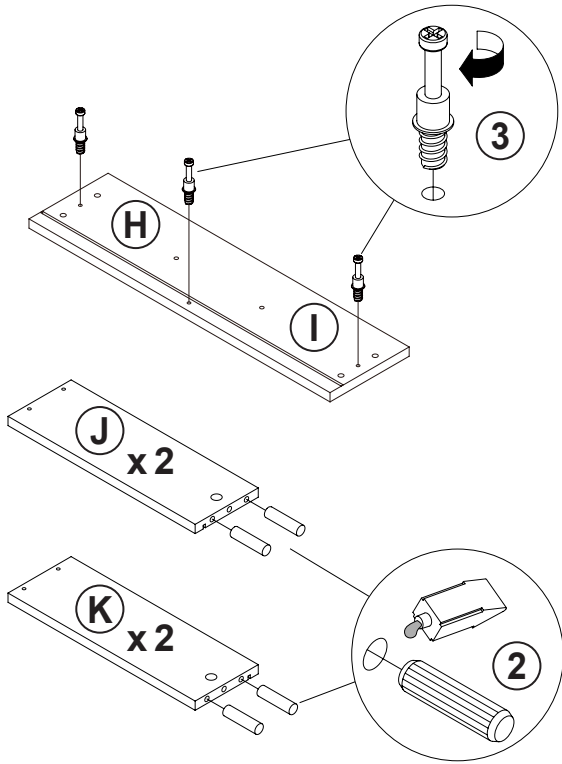
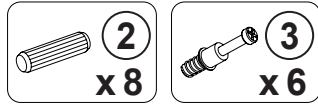

STEP 11

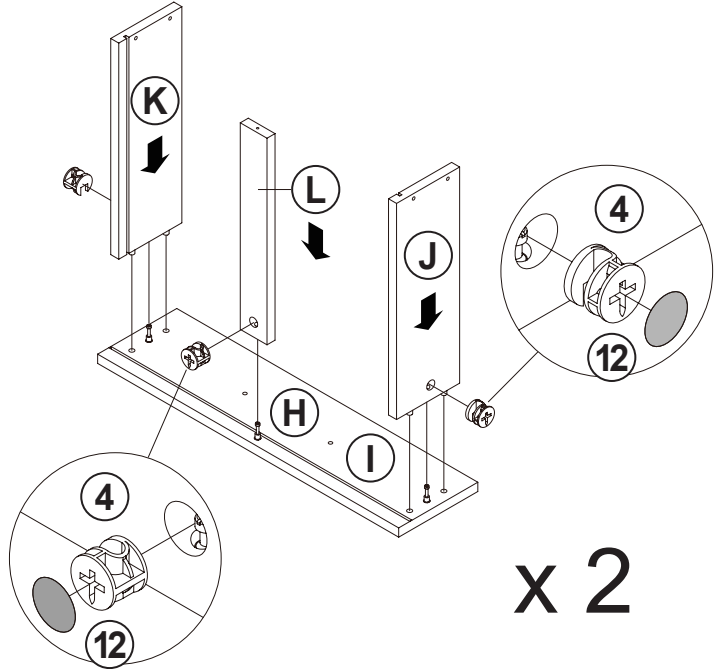
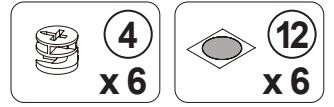

STEP 12

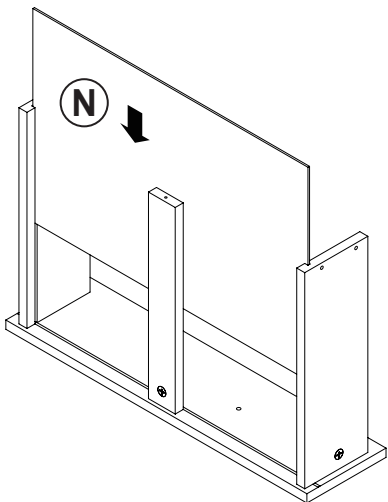

x 2

STEP 13

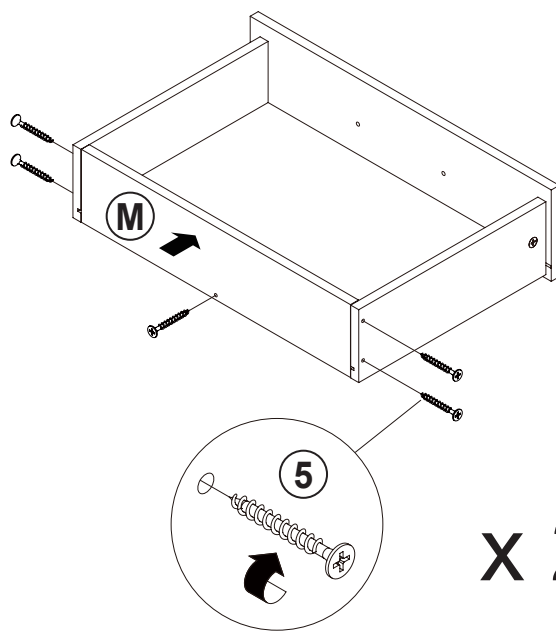
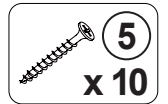

x 2

STEP 14

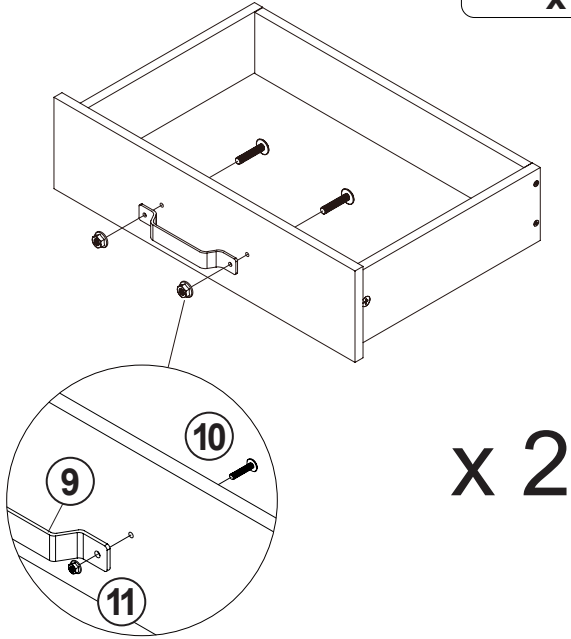
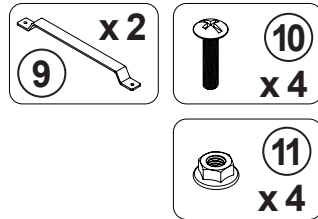

STEP 15

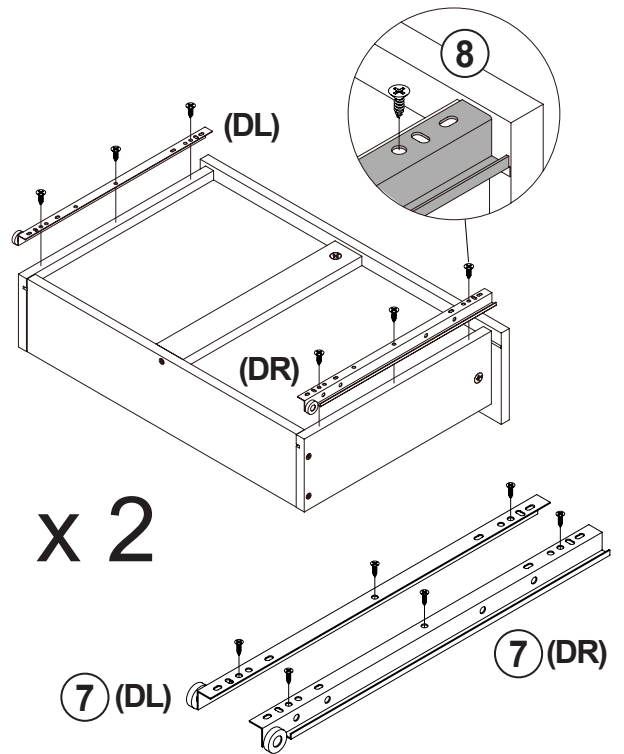
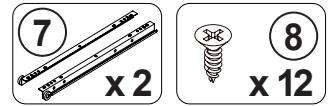

STEP 16

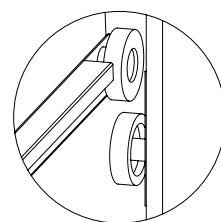
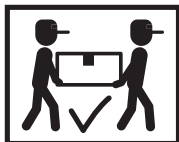
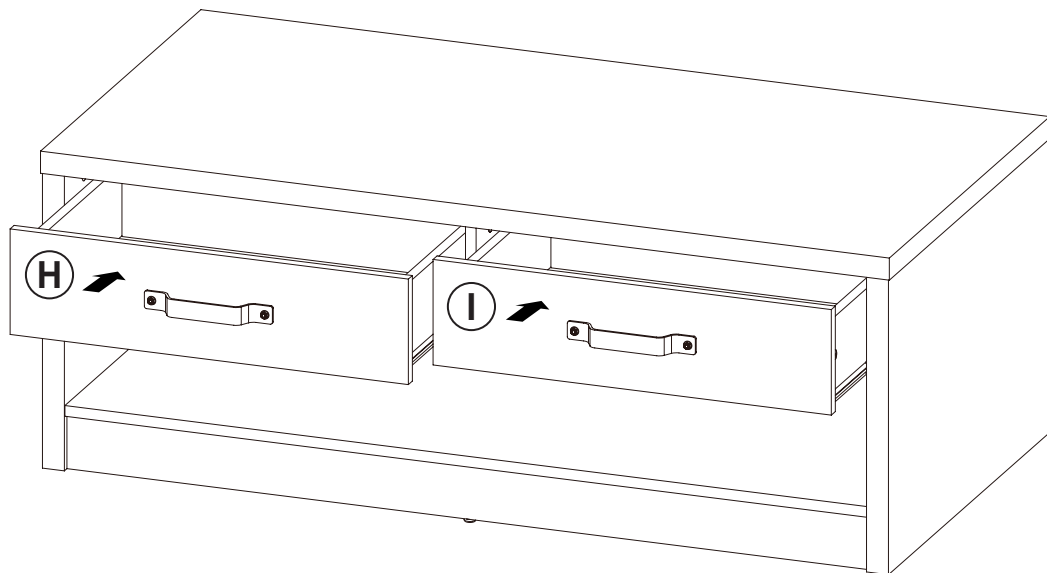

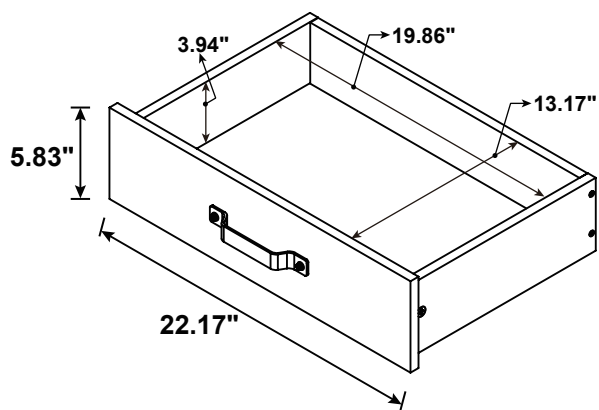
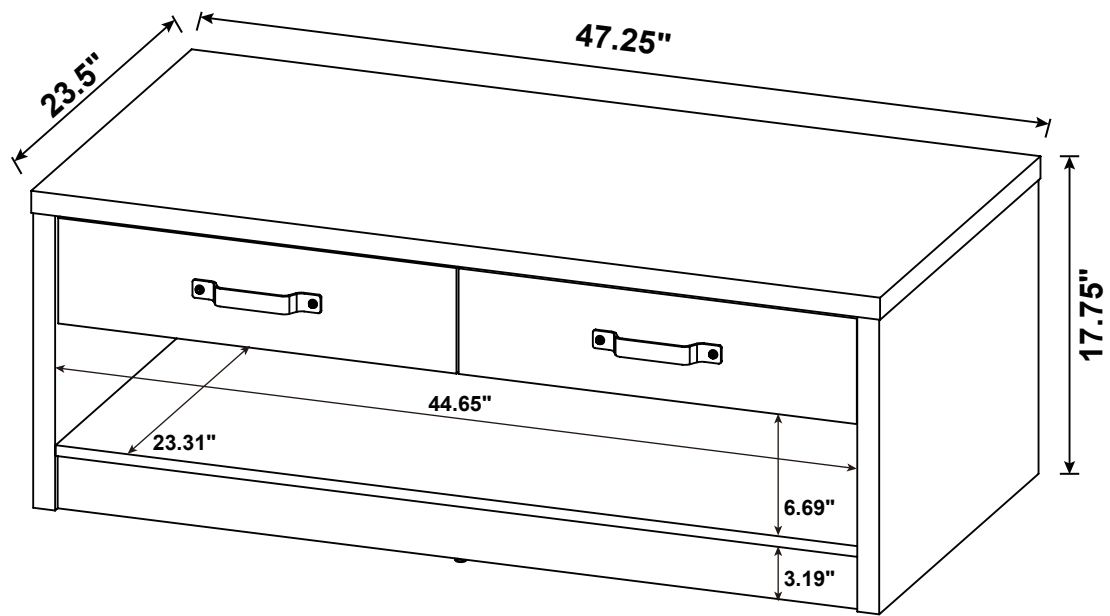

Note : Dimension tolerance $\pm 5\%$